

# Portable Systems





Hutchinson

# Quality Equipment on Your Farm

Hutchinson manufactures quality products, including; portable and stationary grain handling equipment, augers, chain & paddle conveyors, belt conveyors, loop systems, bin unloads and custom augers.

# Top Drive Augers | 6", 8" & 10"

## FEATURES

- 12 ga. housing with 1/4" Flight
- The main tube of the Top Drive is galvanized or powder coat (6" models are galvanized only). Heavy-duty aircraft cable with trussing aid in supporting the main auger
- Wide wheel base design and A-Frame undercarriage constructed of high strength steel that means greater stability during operation or while being towed. The tapered roller bearing hubs permit increased towing capability
- Winch options include manual or labor saving hydraulic and electric winches



## TOP DRIVE AUGER SPECIFICATIONS

MODEL	MAXIMUM DISCHARGE	TIRE CENTER TREAD WIDTH	*HOUSING	ELECTRIC POWER	CAPACITY
6" (15.2 cm) x 31' (9.5m)	21' 8" (6.6 m)	6' 6" (2.0 m)	12 Ga. (2.7 mm)	5 HP (4.0 kW)	2,000 BPH (54 TPH)
6" (15.2 cm) x 41' (12.5 m)	29' 2" (8.9 m)	6' 6" (2.0 m)		5 HP (4.0 kW)	2,000 BPH (54 TPH)
6" (15.2 cm) x 51' (15.5 m)	34' 8" (10.6 m)	7' 6" (2.3 m)		7.5 HP (5.5 kW)	2,000 BPH (54 TPH)
6" (15.2 cm) x 61' (18.6 m)	43' 5" (13.2 m)	7' 6" (2.3 m)		10 HP (7.5 kW)	2,000 BPH (54 TPH)
8" (20.3 cm) x 33' (10.1 m)	22' 6" (6.9 m)	5' 11" (1.8 m)	12 Ga. (2.7 mm)	5 HP (4.0 kW)	3,200 BPH (86 TPH)
8" (20.3 cm) x 41' (12.5 m)	26' (7.9 m)	26' (7.9 m)		7.5 HP (5.5 kW)	3,200 BPH (86 TPH)
8" (20.3 cm) x 47' (14.3 m)	32' (9.8 m)	6' 6" (2.0 m)		7.5 HP (5.5 kW)	3,200 BPH (86 TPH)
8" (20.3 cm) x 53' (16.2 m)	34' (10.4 m)	7' 6" (2.3 m)		10 HP (7.5 kW)	3,200 BPH (86 TPH)
8" (20.3 cm) x 57' (17.4 m)	36' 6" (11.1m)	8' 2" (2.5 m)		10 HP (7.5 kW)	3,200 BPH (86 TPH)
8" (20.3 cm) x 59' (18.0 m)	40' (12.2m)	8' (2.4 m)		15 HP (11.0 kW)	3,200 BPH (86 TPH)
8" (20.3 cm) x 62' (18.9 m)	41' (12.5 m)	8' 8" (2.6 m)		15 HP (11.0 kW)	3,200 BPH (86 TPH)
8" (20.3 cm) x 65' (19.8 m)	43' (13.1 m)	8' 8" (2.6 m)		15 HP (11.0 kW)	3,200 BPH (86 TPH)
8" (20.3 cm) x 71' (21.6 m)	49' (14.9 m)	8' 8" (2.6 m)		20 HP (15.0 kW)	3,200 BPH (86 TPH)
10" (25.4 cm) x 31' (9.5 m)	19'-6" (5.9 m)	6' 7" (2.0 m)		12 Ga. (2.7 mm)	10 HP (7.5 kW)
10" (25.4 cm) x 35' (10.7 m)	21'-6" (6.6 m)	7' 3" (2.2 m)	15 HP (11.0 kW)		4,500 BPH (122 TPH)
10" (25.4 cm) x 41' (12.5 m)	26' (7.9 m)	7' 3" (2.2 m)	15 HP (11.0 kW)		4,500 BPH (122 TPH)
10" (25.4 cm) x 51' (15.5 m)	34' (10.4 m)	8' 2" (2.5 m)	20 HP (15.0 kW)		4,500 BPH (122 TPH)
10" (25.4 cm) x 57' (17.4 m)	37" (11.3 m)	8' 8" (2.6 m)	20 HP (15.0 kW)		4,500 BPH (122 TPH)
10" (25.4 cm) x 61' (18.6 m)	41'-6" (12.7 m)	8' 8" (2.6 m)	20 HP (15.0 kW)		4,500 BPH (122 TPH)
10" (25.4 cm) x 65' (19.8 m)	43" (13.1 m)	8' 8" (2.6 m)	25 HP (18.5 kW)		4,500 BPH (122 TPH)
10" (25.4 cm) x 71' (21.6 m)	49' (14.9 m)	11' 11" (3.6 m)	25 HP (18.5 kW)		4,500 BPH (122 TPH)



### CHOICE OF DRIVES

Your choice of PTO (shown), Electric or Gas. The PTO drive can be driven from either side of the auger. A shear mechanism is incorporated in the PTO driveline for component protection. A band-on support provides a convenient method to carry the driveline during transport.



### SEALED OIL BATH DRIVE

The sealed oil bath drive adds years of life to the drive chain and sprocket as a result of constant self-lubrication. All drivelines are solid steel and supported by low maintenance sealed bearings.

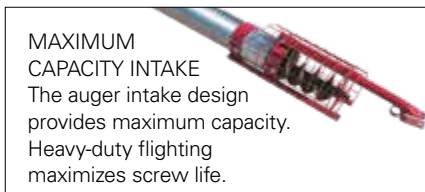

### MAXIMUM CAPACITY INTAKE

The auger intake design provides maximum capacity. Heavy-duty flighting maximizes screw life.

### ADDITIONAL OPTIONS

- Intermediate Flight Bearings on all models
- In-Line Style Intake Guard

# Top Drive Augers | 13"

## FEATURES

- 12 ga. Housing with 1/4" Flight
- Intake guard with hitch
- PTO or electric drive options – incorporates oil
- lubricated gear drive
- Winch options include manual (36' and 52' only), Hydraulic or Electric 82' model incorporates adjustable axle width for transport

## OPTIONAL FEATURES

- Flex bin hopper for 36'
- Metal folding hopper kit
- Tapered hopper kit
- Pit auger optional intake



## TOP DRIVE AUGER SPECIFICATIONS

MODEL	MAXIMUM DISCHARGE	TIRE CENTER TREAD WIDTH	*HOUSING	ELECTRIC POWER	CAPACITY
13" (33.0 cm) x 36' (11.0 m)	23' (7.1 m)	8' 2" (2.5 m)	12 Ga.	25 HP (18.5 kW)	7,500 BPH
13" (33.0 cm) x 52' (19.8 m)	32' (9.75 m)	10' (3.05 m)		25 HP (18.5 kW)	7,500 BPH
13" (33.0 cm) x 62' (18.9 m)	42' 2" (12.8 m)	12' (3.66 m)		40 HP (30.0 kW)	7,500 BPH
13" (33.0 cm) x 65' (19.8 m)	43' 10" (12.4 m)	12' (3.66 m)		40 HP (30.0 kW)	7,500 BPH
13" (33.0 cm) x 72' (22.0 m)	47' 6" (14.5 m)	12' (3.66 m)		50 HP (37.0 kW)	7,500 BPH
13" (33.0 cm) x 82' (25.0 m)	5' (15.5 m)	12' (3.66 m)		60 HP (45.0 kW)	7,500 BPH



Double oil bath gearbox head drive



Electric drive option



PTO drive option



Intake with jack shown with tapered hopper kit

# Portable Grain Pumps

## FEATURES

- Requires less horsepower than air systems
- En masse (grain-moving-grain) concept causes less damage to grain at higher capacities and needs less maintenance than traditional conveying systems.
- Unique Ultra High Molecular Weight (UHMW) paddle, designed to keep your grain flowing gently and evenly from inlet to discharge
- Reduction in grain damage when compared to traditional conveying systems



## PORTABLE GRAIN PUMP SPECIFICATIONS

MODEL	MAXIMUM DISCHARGE	OVERALL TREAD WIDTH	GALVANIZED HOUSING	CONVEYOR CHAIN	ELECTRIC POWER	CAPACITY
8" (20.3 cm) x 42' (12.8 m)	24' 2" (7.4 m)	9' 6" (2.9 m)	12 Ga. (2.7mm)	81 X	10 HP (7.5 kW)	4,000 BPH (108 TPH)
8" (20.3 cm) x 52' (15.9 m)	31' 7" (9.6 m)	9' 6" (2.9 m)		81 X	15 HP (11.0 kW)	4,000 BPH (108 TPH)
8" (20.3 cm) x 62' (18.9 m)	38' (11.6 m)	11' (3.35 m)		81 X	15 HP (11.0 kW)	4,000 BPH (108 TPH)
8" (20.3 cm) x 72' (22.0 m)	44' 3" (13.5 m)	13' (3.96 m)		81 X	20 HP (15.0 kW)	4,000 BPH (108 TPH)
8" (20.3 cm) x 82' (25 m)	50' (15.2 m)	10' (3.0 m)		81 X	20 HP (15.0 kW)	4,000 BPH (108 TPH)
10" (20.3 cm) x 42' (12.8 m)	25' 5" (7.8 m)	11' (3.35 m)	12 Ga. (2.7mm)	81 XHH	15 HP (18.5 kW)	6,000 BPH (162 TPH)
10" (20.3 cm) x 52' (15.9 m)	32' 10" (10.0 m)	11' (3.35 m)		81 XHH	20 HP (14.9 kW)	6,000 BPH (162 TPH)
10" (20.3 cm) x 62' (18.9 m)	39' 4" (12.0 m)	11-0" (3.35 m)		81 XHH	25 HP (18.5 kW)	6,000 BPH (162 TPH)
10" (25.4 cm) x 72' (22.0 m)	45' 8" (13.9 m)	13" (3.96 m)		81 XHH	25 HP (18.5 kW)	6,000 BPH (162 TPH)
10" (25.4 cm) x 82' (25.0 m)	50' 9" (15.5 m)	10' (3.0 m)		81 XHH	30 HP (22.0 kW)	6,000 BPH (162 TPH)
12" (30.5 cm) x 130' (39.62 m)	85' 3" (26.0 m)	14' (4.3 m)	10 Ga. (3.4 mm)	81 XHH	60-75 HP (44.7 kW- 55.9 kW)	10,000 BPH (270 TPH)



**HEAD CHAIN ADJUSTMENT**  
Threaded rods on each side of the head allows ease of conveyor chain adjustment. Optional discharge 90° spout shown.



Gently Handles a Wide Variety of Grains



**HEAVY-DUTY WINCH SYSTEM**  
Hydraulic, Electric and Hand Winches are available. All winches are ordered separately.



**HEAVY DUTY ENCLOSED GEAR BOX**  
Rigorous gear reducer boot drive furnishes reliable power for driving the machine. Shown with PTO drive.

# Mass-Ter Mover

The Mass-ter® Mover line is Hutchinson's answer to "en masse" conveying systems. You get top performance, long life and reliability with minimum maintenance engineered into each component.

## FEATURES

- Requires less horsepower than a screw conveyor
- En masse (grain-moving-grain) concept causes less damage to grain at higher capacities and needs less maintenance than traditional conveying systems
- Unique Ultra High Molecular Weight (UHMW) paddle, designed to keep your grain flowing gently and evenly from inlet to discharge



## PORTABLE MASS-TER MOVER SPECIFICATIONS

MODEL	LENGTH	MAXIMUM DISCHARGE	TIRE CENTER TREAD WIDTH	GALVANIZED HOUSING	CONVEYOR CHAIN	CHAIN SPEED	ELECTRIC POWER	CAPACITY	
50	40' (12.2 m)	24' 10" (7.6 m)	8' 2" (2.5 m)	10 Ga. (3.4 mm)	81 XHH	310 FPM (95 mpm)	15 HP (11.0 kW)	5,000 BPH (135 TPH)	
50	50' (15.2 m)	34' (10.4 m)	8' 9" (2.7 m)		81 XHH	310 FPM (95 mpm)	15 HP (11.0 kW)	5,000 BPH (135 TPH)	
50	60' (18.3 m)	40' 7" (12.4 m)	8' 9" (2.7 m)		81 XHH	310 FPM (95 mpm)	20 HP (15.0 kW)	5,000 BPH (135 TPH)	
50	65' (19.8 m)	44' 1" (13.4 m)	8' 9" (2.7 m)		81 XHH	310 FPM (95 mpm)	20 HP (15.0 kW)	5,000 BPH (135 TPH)	
50	70' (21.3 m)	43' 1" (13.1 m)	10' 11" (3.3 m)		81 XHH	310 FPM (95 mpm)	20 HP (15.0 kW)	5,000 BPH (135 TPH)	
50	80' (24.4 m)	49' 6" (15.1 m)	11' 11" (3.6 m)		81 XHH	310 FPM (95 mpm)	25 HP (18.5 kW)	5,000 BPH (135 TPH)	
50	90' (27.4 m)	55' 11" (17.0 m)	14' 3" (4.3 m)		81 XHH	310 FPM (95 mpm)	25 HP (18.5 kW)	5,000 BPH (135 TPH)	
50	100' (30.5 m)	62' 4" (19.0 m)	14' 3" (4.3 m)		81 XHH	310 FPM (95 mpm)	25 HP (18.5 kW)	5,000 BPH (135 TPH)	
85	40' (12.2 m)	24' 4" (7.4 m)	9' (2.7 m)		10 Ga. (3.4 mm)	81 XHH	400 FPM (122 mpm)	20 HP (15.0 kW)	10,000 BPH (270 TPH)
85	65' (19.8 m)	40' 5" (12.3 m)	12' (3.7 m)			81 XHH	400 FPM (122 mpm)	30 HP (22.0 kW)	10,000 BPH (270 TPH)
85	70' (21.3 m)	43' 8" (13.3 m)	12' (3.7 m)	81 XHH		400 FPM (122 mpm)	40 HP (30.0 kW)	10,000 BPH (270 TPH)	
85	80' (24.4 m)	50' 3" (15.3 m)	11' 8" (3.6 m)	81 XHH		400 FPM (122 mpm)	40 HP (30.0 kW)	10,000 BPH (270 TPH)	
85	90' (27.4 m)	57' 3" (17.5 m)	11' 8" (3.6 m)	81 XHH		400 FPM (122 mpm)	50 HP (37.0 kW)	10,000 BPH (270 TPH)	

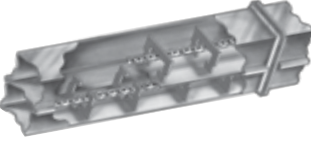

**MASS-TER® MOVER'S UNIQUE CHAIN AND PADDLE DESIGN**  
The unique shape of tough UHMW paddles maintains full chamber movement of grain... without fall-back. The open centers of the paddles provide relief when starting under a partial load. And, our square paddle propulsion system requires less horsepower than a screw conveyor – up to 30% energy savings can be gained! Whether you're starting from the ground up, or updating your present facilities, you'll find the Hutchinson Mass-ter Mover® ready to meet your demands.



**PTO DRIVE**  
The PTO drive provides a shear mechanism into the PTO driveline for component protection.



**HYDRAULIC WINCH SYSTEM**  
The hydraulic winch that is standard on longer units provides a smooth dependable method to raise and lower the conveyor. An optional electric winch is available for selected lengths.



**ELECTRIC DRIVE**  
Electric drive arrangement shown with optional 12" (30.5 cm) inlet hopper extension.

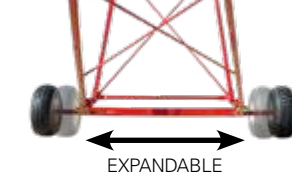

**EXPANDABLE AXLE**  
Available on Model 85 – 80' and 90' units, the expandable axle provides stability and a more convenient transport width.

# Drive-Over Chain Conveyor

## FEATURES

- Low profile 8 3/4" (22.2 cm) unit makes operation of driving over and unloading an effortless task
- Portability provides convenience of quickly moving to next location. Lower the wheels, fold up the ramps and you are ready to go
- Long ramps available



## DRIVE-OVER CHAIN CONVEYOR SPECIFICATIONS

DISCHARGE HEIGHT	OVERALL TREAD WIDTH	HOPPER BOTTOM	CONVEYOR CHAIN	CHAIN SPEED	ELECTRIC POWER	CAPACITY
3' 1" (0.9 m)	5'-1" (1.6 m)	7 Ga. (4.5 mm)	CA550	385 FPM (117 mpm)	10 HP (7.5 kW)	3,500-8,000 BPH (216 TPH)

	<p>Electric jack shaft drive furnishes an economical, reliable drive. Hydraulic motor drive is also available.</p>		<p>Reinforced ramps will fold for narrow transport width.</p>
	<p>Rotating the axle by employing the ratchet jack along with using the hitch jack allows easy conversion for hopper transportation.</p>		<p>Removable hitch allows for additional operator convenience during operation.</p>
	<p>Optional side unload kit.</p>		<p>Standard spring assist ramps for ease of handling.</p>

# Trac Mass-Ter

The Hutchinson Trac Mass-ter is a unique conveyor. Two industry-preferred conveying methods are combined to maximize efficiency and minimize wear. A large diameter, low speed screw in the hopper moves grain to the inclined chain conveyor where Ultra High Molecular Weight (UHMW) paddles quickly but gently carry the material from intake to discharge. Patterned after the model 85 Mass-ter® Mover, the Trac Mass-ter incline conveyor is a versatile performer that has been utilized in horizontal or inclined applications on many large farms and commercial operations. It performs well where low horsepower requirements, quiet operation, gentle handling and longevity are important. Combined with the large 16" screw conveyor intake, this product is ready for those jobs requiring day after day operation.

## FEATURES

- Operate from the comfort of a tractor cab
- Attachment to the tractor is as quick as aligning and installing three pins followed by hydraulic and PTO connections. With attachments at the front and rear of the tractor, the conveyor moves with the tractor just as a mounted unit
- Totally self-supporting undercarriage, even when not attached to the tractor



## ACCESSORIES

- Hydraulic adjustable spout
- Hydraulic swivel spout
- Enclosed intake hopper assembly
- Adaptor kit for Cat. #3 three-point hitch
- Standard AR lining

## TRAC MASS-TER SPECIFICATIONS

LENGTH	MAXIMUM DISCHARGE	OVERALL TREAD WIDTH	GALVANIZED HOUSING	CONVEYOR CHAIN	CHAIN SPEED	PTO POWER	CAPACITY
40'(12.2 m)	21' 6"(6.6 m)	13' 4"(4.1 m)	10 Ga. (3.4 mm) Bottom	81 XHH	397 FPM (121 mpm)	90 HP (67 kW)	10,000 BPH (270 TPH)

<p><b>HYDRAULIC LIFT UNDERCARRIAGE</b> Raising and lowering is done easily and smoothly with your tractor's hydraulics.</p>	<p><b>OPTIONAL HYDRAULIC ADJUSTABLE SPOUT</b> Use the optional hydraulic swivel spout to vary the discharge point to facilitate truck load out.</p>	<p><b>OPTIONAL INTAKE HOPPER ASSEMBLY</b> Use the optional intake hopper to fill your flat storage facilities.</p>

# Commercial Drive-Over Chain Conveyor



## FEATURES

- Up to 10,000 BPH capacity (Electric drive with Dodge gear reducer)
- Removable drive-over covers create a full width receiving hopper
- Hydraulic folding ramps with extensions available
- Perfect for our Portable Grain Pumps and Mass-Ter® Movers
- Stationary model available (less ramps and axle)
- 3/8" Thick UHMW paddles and 7 Ga. housing
- AR Divider Panel

## DRIVE-OVER CHAIN CONVEYOR SPECIFICATIONS

CATALOG NO.	A	B
CDC10002E8	17' 9 1/8"	7' 5/8"
CDC10002E8-XR*	23'	9' 8"
CDC10002E8-XFR*	33' 3 7/8"	14' 9 15/16"

\*Options for ramp extensions



Integrated grating 3'-6 3/4" x 3'-8"  
(optional full-width grating available)



Hydraulic ramps and axle for quick setup and transportation

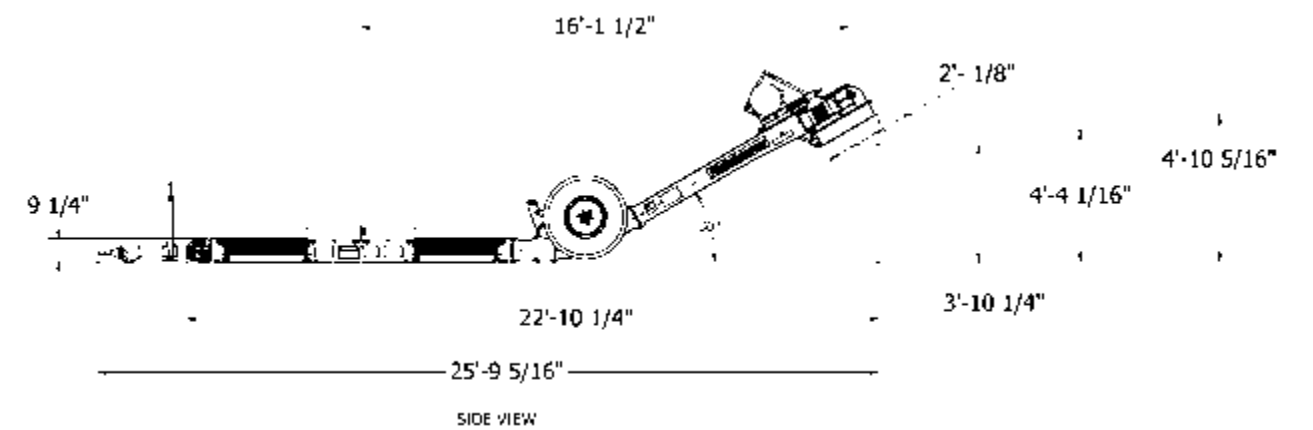
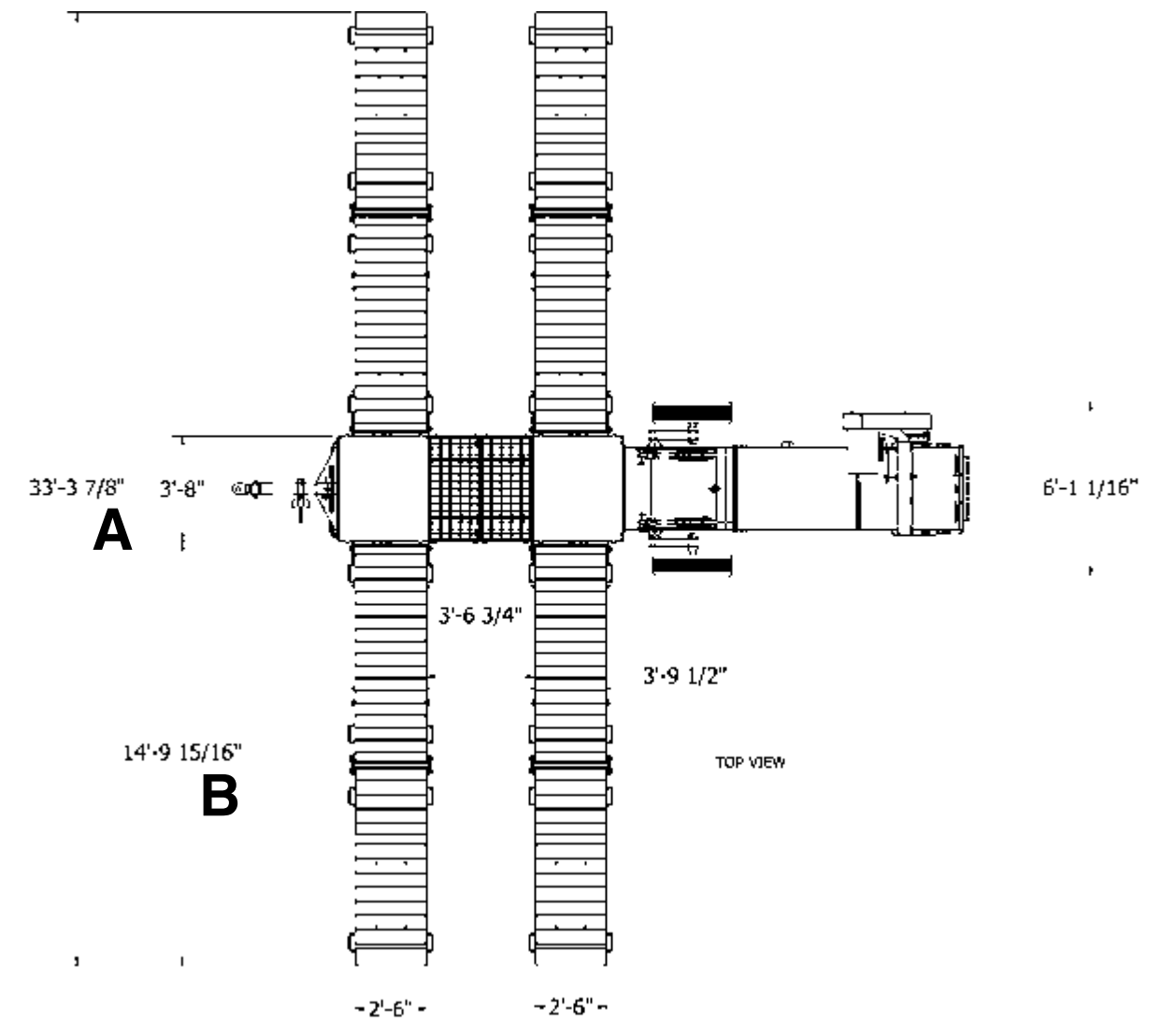



**Hutchinson is an AGI Brand.**

AGI is a leading provider of equipment solutions for agriculture bulk commodities including seed, fertilizer, grain, and feed systems with a growing platform in providing equipment and solutions for food processing facilities. AGI has manufacturing facilities in Canada, the United States, the United Kingdom, Brazil, South Africa and Italy and distributes its products globally.

# **AGI** **HUTCHINSON**

P.O. Box 629, 74, Clay Center, Kansas, USA 67432  
785.632.2161 | hutchinson-mayrath.com

AGGROWTH.COM      @aggrowthintl