



BATCO FX⁴ 18S

12 3/4" tube
18" belt
Up to 10,500 BPH
39' | 44' lengths

The FX⁴ now bigger, better and built to move up to 10,500 bph. This high-capacity electric conveyor is your go-to solution for fast, efficient bin unloads.

Features

Parallel hopper cloth stays 36 3/8" wide for the full working length.

Cloth frame updated for improved collapsibility and enhanced clearance.

Collapsible hopper

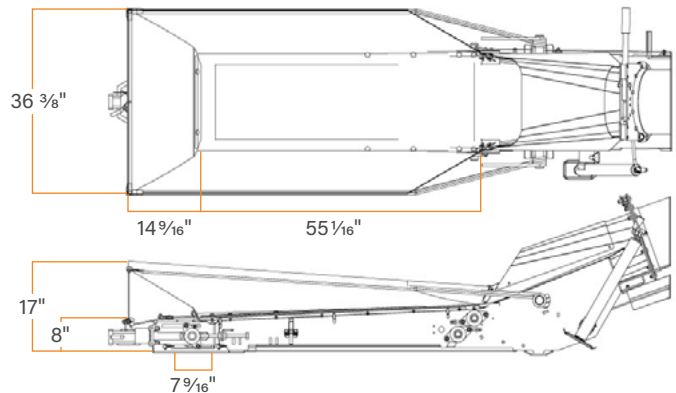

Features

43 3/4" steel base for enhanced durability.

Rubber brim allows ample clearance beneath most bin unloads.

Steel hopper

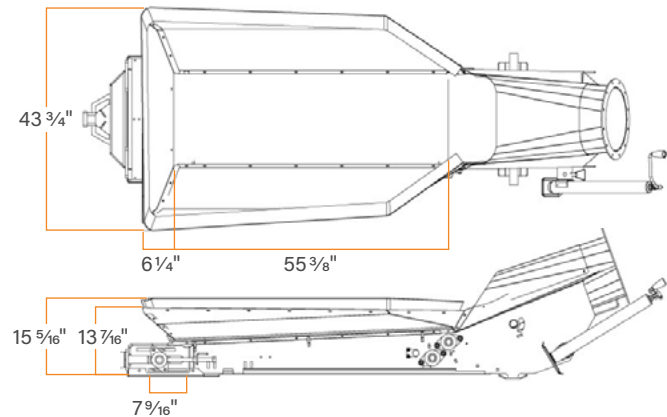

No-nonsense discharge hood

Grain flows straight down from the spout.

New pinch drive roller

For reliable belt traction in adverse conditions.

12 3/4" tube with an 18" belt

43% more capacity over 15S FX⁴.

Larger drive roller

To better handle higher capacities made possible with the 12.75" tube and 18" belt. (5" OD, up from 4 1/4")

Lower profile collapsible hopper & handle

More clearance under bins, easier setup and better maneuverability in tight spaces.

New steel hopper option

Simple, rigid, non-collapsing hopper option. No springs, no cables, no fuss.



BATCO FX⁴ 18S



FX ⁴ 18S	1839	1844
Capacity	Up to 10,500 bph	
Tube gauge	12 3/4" x 12 ga	
Belt type	18' wide chevron	
Belt length	84' 1"	94' 1"
Lift	Hand winch	
Frame type	A-frame	
Axle	2 1/2" sq. x 1/8"	
Hub	4-bolt on 5.0", 3.62" pilot	
Tires	4-bolt ST205/75D15	
Parking jack	1000 lbs rating, top twist, 2 1/2" receiver, 15" travel	
Hopper dimensions	54 3/4" length x 36 3/8" width x 21 7/8" height	
HP required (with dry wheat)	Electric 12.5 hp/15 hp	Electric 15 hp
Conveyor width (hub face to face)	7.5' (90")	
Conveyor weight	1950.5 lbs	2064.5 lbs

FX ⁴ 18S	Height lowered	Height halfway	Height raised	Reach lowered	Reach halfway	Reach raised	Height at lift arms halfway	Height at wheels raised	Reach at lift arms halfway	Reach at wheels raised	Height at 23° angle to bottom of spout
1839 FLTD	8' 1.75" (2.48 m)	14' 1.25" (4.30 m)	18' 1" (5.51 m)	17' 10" (5.44 m)	17' 3" (5.25 m)	16' 10" (5.13 m)	8' 11.75" (2.73 m)	10' 4.25" (3.16 m)	15' 7.5" (4.76 m)	16' 10" (5.13 m)	13' 0.25" (3.96 m)
1844 FLTD	6' 6.18" (1.98 m)	13' 10" (4.21 m)	18' 1.62" (5.53 m)	21' 3.18" (6.48 m)	20' 8.75" (6.32 m)	20' 5.37" (6.23 m)	8' 6.43" (2.60 m)	9' 8.37" (2.96 m)	18' 4.5" (5.60 m)	20' 5.37" (6.23 m)	14' 11.87" (4.57 m)

Heights measured from bottom of conveyor spout to ground.