



STX2/XTA REVERSIBLE GEARBOX KIT [A391, A393] INSTALLATION INSTRUCTIONS

Note: *During assembly, ensure the reversible gearbox components do not interfere with any other auger components.*

Refer to Figure 1 for assembly detail.

1. If present, remove the existing gearbox from the auger.
2. Install the new reversing gearbox, chain coupler, and belt pulley as detailed in the auger assembly manual. Be sure to reattach all guards.

Note: *The following steps are not required for the 31' models.*

3. Mount the detent lever assembly to the auger tube.
4. Use the gearbox shifter to move the gearbox into either forward or reverse position.
5. Move the detent lever to the same position as the gearbox shifter (forward or reverse). Ensure the lock pin is engaged with the bracket.
6. Attach the gearbox push rod to the straight gearbox handle extension.
7. Thread the adjust lug roughly halfway into the straight gearbox handle extension.
8. Connect the gearbox push rod to the gearbox shifter.
This joint must pivot — do not over-tighten.
9. Loosely attach the adjust lug to the detent lever.
10. Disengage the lock pin and move the detent lever from forward to reverse a few times.
 - Ensure the gearbox fully engages in both directions when moving the lever back and forth.
 - The gearbox should be fully engaged when the lock pin is in the hole.
11. If the gearbox does not shift evenly in both directions, use the adjust lug to increase or decrease the length of the gearbox handle extension as required.

Westfield | Wheatheart
part of the Ag Growth International group
P.O. Box 39, Rosenort, Manitoba, Canada R0G 1W0 Ph: (866) 467-7207 Fax: (866) 768-4852
Website: www.grainaugers.com | www.wheatheart.com Email: sales@grainaugers.com | sales@wheatheart.com
© Ag Growth International Inc. 2019

Figure 1 Detent Lever and Offset Tube Attachment

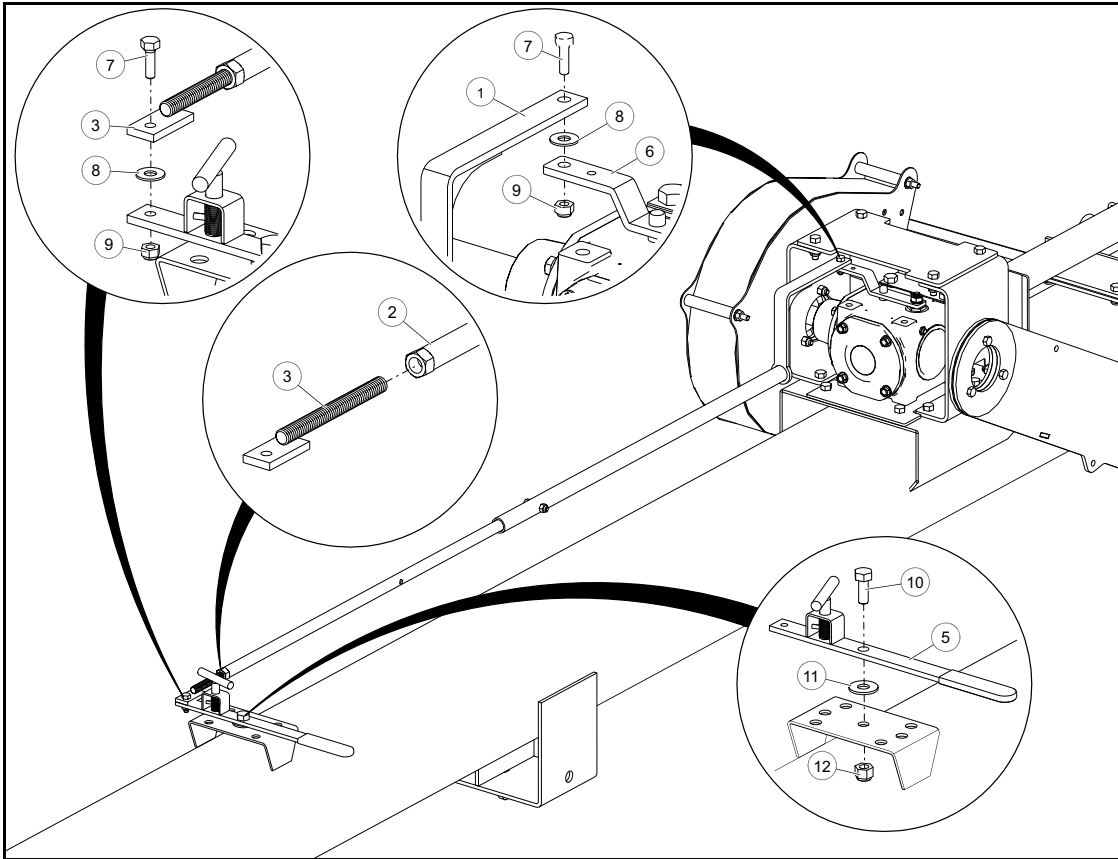

Figure 2 Hole Positions in Straight Gearbox Handle Extension

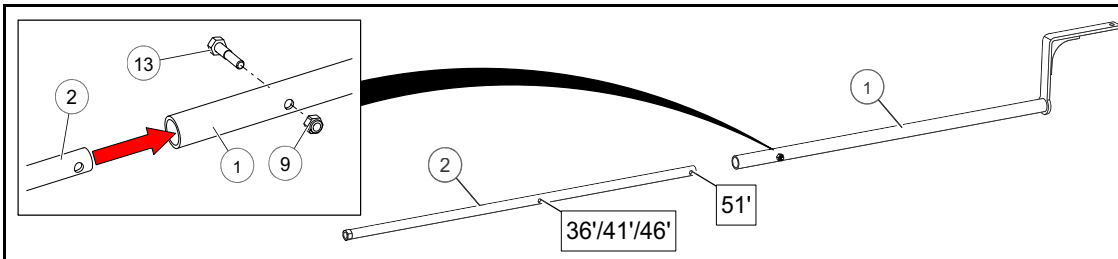

Table 1.1 Detent Lever and Offset Tube Attachment Items

Item	Description	Item	Description
1	Gearbox Push Rod	8	Flat Washer, 5/16"
2	Gearbox Handle Extension, Straight	9	Locknut, 5/16"
3	Adjust Lug	10	Bolt, 1/2" x 1-1/4"
4	Lock Pin	11	Flat Washer, 1/2"
5	Detent Lever Assembly	12	Locknut, 1/2"
6	Gearbox Shifter	13	Bolt, 5/16" x 1-1/2"
7	Bolt, 5/16" x 1"		