



A224/A225 Electric Clutch Kit Double-Groove Pulley Installation Instructions

Applicable Models:

STX2 & XTA Series

Install the Electric Clutch

Note

Apply anti-seize to the engine shaft where the electric clutch will slide on.

1. Slide the square shaft key (3) and electric clutch (2) onto the engine shaft (1).
2. Secure the electric clutch to the engine shaft using a $3/8"$ x $3"$ bolt (4) or $7/16"$ x $3"$ bolt (4) (engine-model dependent) and lock washer (5).

Note

When properly adjusted the electric clutch should be tight and unable to slide on the shaft.

3. Place the motor so that the gap between the face of the electric clutch and the inside face of the guard attach bracket is $2-5/16"$.
4. Connect all belts.
5. Position the $5/16"$ x $5"$ bolt (6) so that it fits into the clutch case slot to prevent the clutch from rotating, and secure it with two $5/16"$ whiznuts (7).

Figure 1. Installing the Electric Clutch

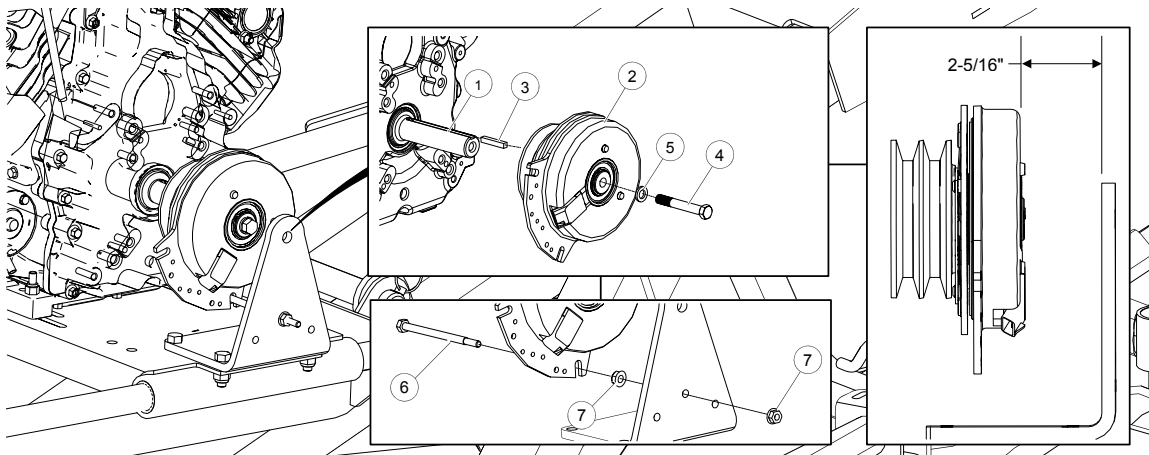

Wire the Electric Clutch

1. Plug the clutch wiring harness into the clutch, and position the other end of the harness in a way that leaves it accessible for external wiring.
2. Complete the remaining electrical connections, using 14 gauge crimp connectors (splice, spade, and ring terminal) as needed:
 - connect the white switch cable wire to one of the clutch harness connector terminals;
 - connect the black switch cable wire to the fuse, and from there to 12 VDC power;
 - connect the remaining clutch harness connector terminal to ground.
3. Test the switch to ensure that the electric clutch engages and disengages properly.
4. Use electrical tape to seal and secure any electrical connections that might require weather-proofing.
5. Run the electrical cable through the lower frame to prevent accidental disconnection of wiring if the cable is pulled tight.
6. Secure the cable when not in use.

Figure 2. Electric Clutch Wiring Diagram

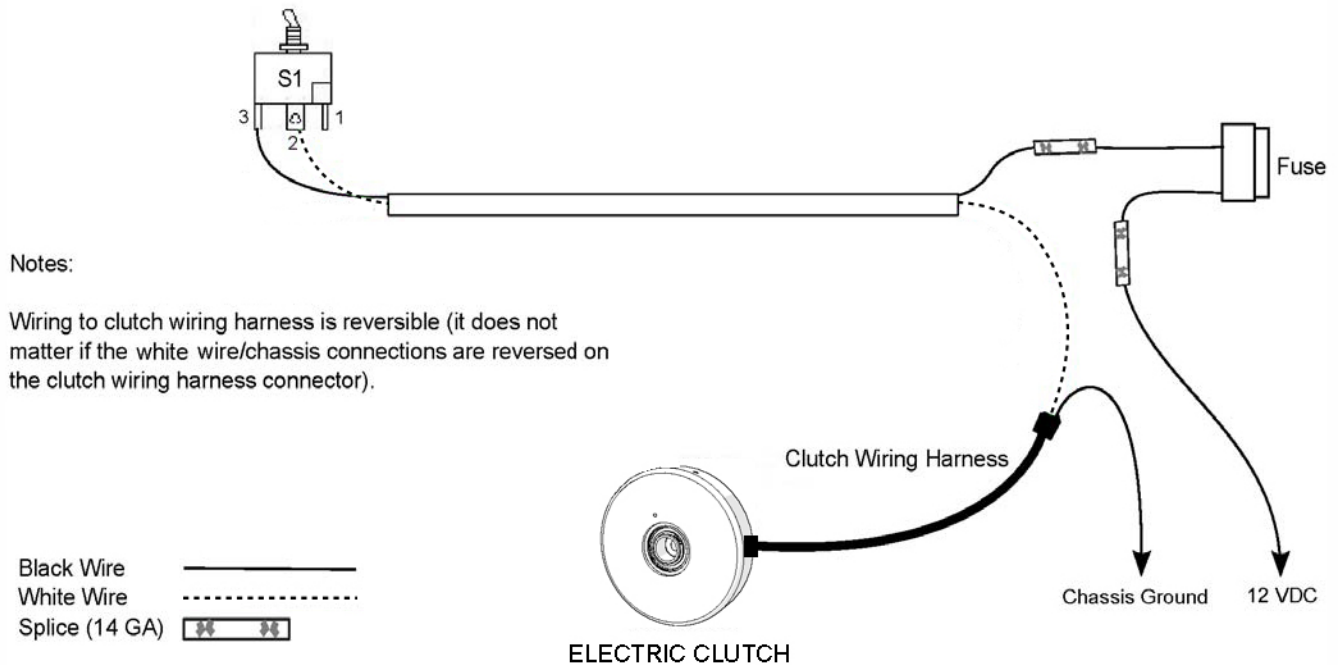

P.O. Box 39
 Rosenort, Manitoba, R0G 1W0 Canada
 Phone: (866) 467-7207 (Canada & USA) or (204) 746-2396
 Fax: (866) 768-4852

Website: www.grainaugers.com
 Email: sales@grainaugers.com
 ©Ag Growth International Inc. 2019, Printed in Canada