

WESTFIELD

LOW PROFILE HOPPER ASSEMBLY For S10, S13, A180 and A181

Lock out power to the auger before assembling.

MK ONLY

NOTE: The gearbox has been filled at the factory (half full) with EP90 gear oil. Before further assembly, check oil level to make certain the gearbox is half full as required. Add oil if necessary. Do not use grease.

1. Attach the pivot-connector to appropriate 10" or 13" holes in hopper with two 5/8" x 1-1/2" bolts and locknuts (see **Figure No. 2**). DO NOT OVERTIGHTEN, tighten snug only as these bolts act as pivot points.
2. Loosely secure the service door with the two square latch-washers and 3/8" locknuts.

NOTE: These must be tightened securely after hopper assembly is completed.

3. Clean dirt and paint from inside u-joint and flight shaft end, then insert Woodruff key.
4. Raise and support hopper tube at about 50" under spout. Open service door on hopper, then bring tube and hopper together guiding flight shaft into u-joint. (See **Figure No. 1**)

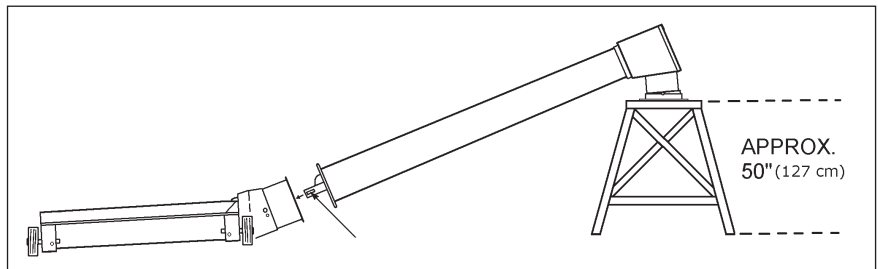

Figure No. 1

5. Secure tube to pivot-connector on hopper with 7/16" x 1" bolts and locknuts.
6. Tighten set screws on u-joints, then close and secure the service door.
7. Attach the two piece rubber extension to inside of hopper lip with 5/16" x 3/4" bolts and washer locknuts and flat iron straps provided plus the two piece extension connector plates. (See **Figure No. 2**)

NOTE: To attach the rubber extension to end of hopper, remove the two 5/16" washer locknuts that secure the chain drive shield.

8. Attach the four pneumatic wheels to the four hopper corners with the axle pins and hairpins. The offset portion of the wheel must rest against the hopper. You have a choice of three height settings. (See **Figure No. 2**)

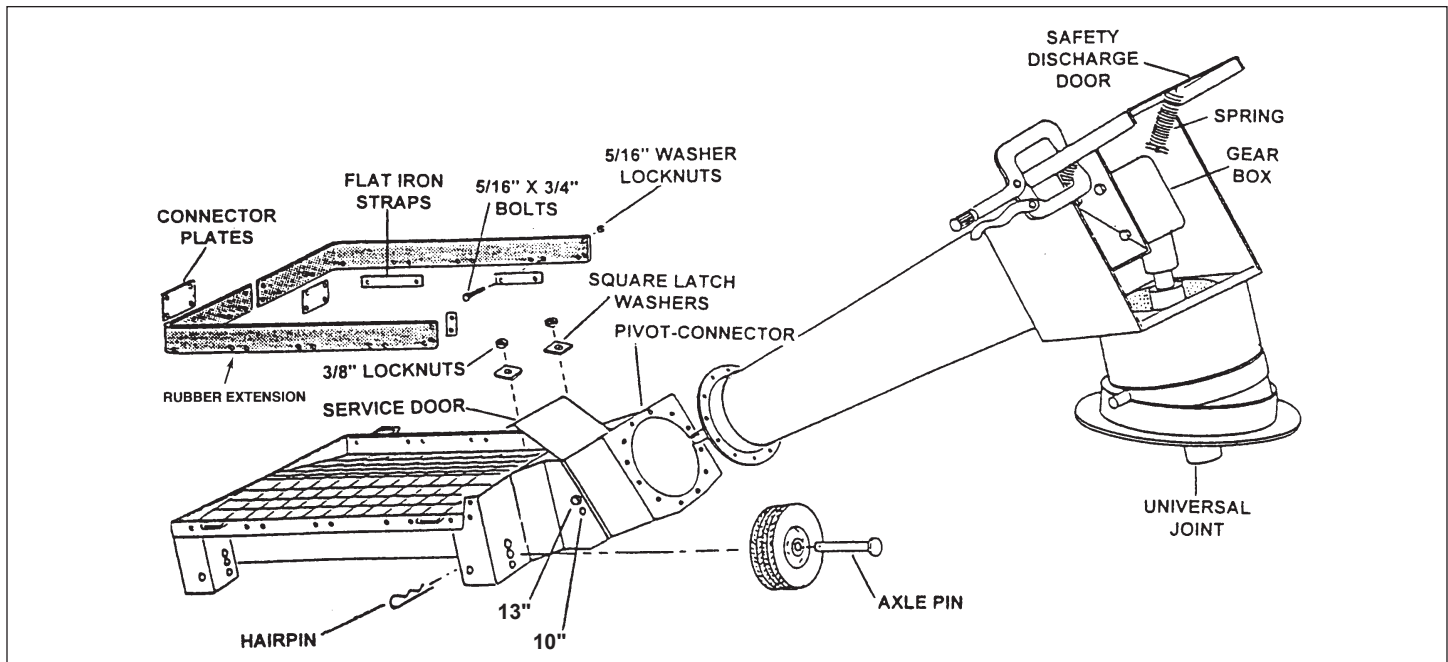

Figure No. 2

MK ONLY

9. To connect the intake hopper to the auger boot, the safety discharge door must be opened. This door is held in place internally with two springs. To open, pull the door down and then up and over the gearbox enclosure. Hold open with C-clamp vise grip.
10. Place wide rim 1-1/4" washer shield over splined shaft on lower gear box. Check that the u-joint spline and splined shaft on lower gear box are clean, then apply a light film of grease on this splined shaft.
11. As the intake hopper is lowered onto the boot, the splined universal joint must be guided onto the splined shaft. Once positioned, swivel ring should be resting flat on the boot surface and inside the four spacer nuts.
12. Install four large washers with 3/8" x 3/4" bolts to keep the intake hopper in place on the boot. (See **Figure No. 3**)
13. Lubricate the universal joint and then close the safety discharge door. **KEEP IT CLOSED DURING OPERATION.**

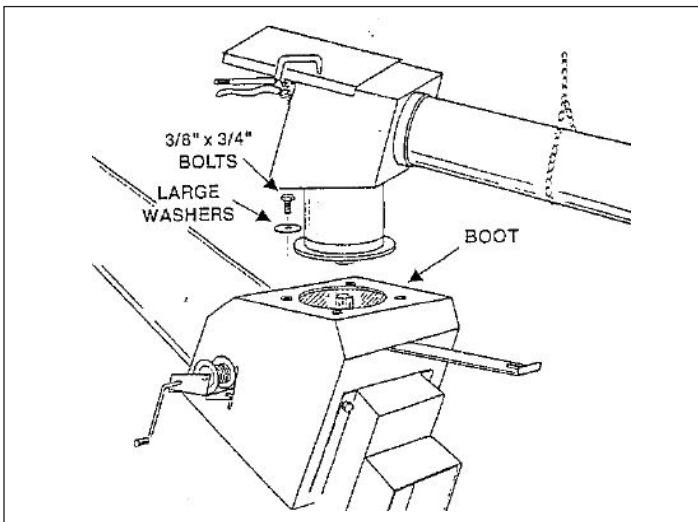

Figure No. 3

DANGER

ROTATING FLIGHTING INSIDE

To prevent serious injury or death, do not operate auger unless swing-hopper is securely attached to boot.

WESTFIELD

P.O. Box 39, Rosenort, Manitoba, R0G 1W0 Canada
Phone: (866) 467-7207 (Canada & USA) or (204) 746-2396 Fax: (866) 768-4852
Website: www.grainaugers.com Email: sales@grainaugers.com
©Ag Growth International Inc. 2018

MAINTENANCE OF LOW PROFILE HOPPER

Before attempting maintenance, SHUT OFF and LOCK OUT all power to hopper.

Frequent:

Loosen the two nuts securing the service door. Open door - then grease the four bushings and the two u-joints. Close door, then securely tighten the two 3/8" nuts.

Occasional:

1. Check and adjust the hopper drive chain.
2. Lubricate the hopper drive chain.

(For all other instructions, see *Operator's Manual*.)

MK ONLY

How to install new LIFT arm to retrofit LP hopper to previous MK100 & MK130 augers equipped with ONE ONLY lift arm mount bracket.

1. With auger lowered, remove standard hopper from boot. Assemble low profile hopper and attach to auger boot as per previous instructions.
2. Remove present lift arm and cable, then attach the strap-on lift arm mount bracket above present bracket as shown (see **Figure No. 4**) with the MK100 bracket at 27-1/2" and the MK130 at 31". Measure from upper edge of each bracket.
3. Secure lift arm to mount bracket, then thread cable through lift arm and attach to winch as shown in manual.
4. To place hopper into transport, attach cable hook to hook in hopper, then raise fully with intake side of hopper facing main auger. Secure hopper to lift arm with a saddle pin and hairpin provided.

NOTE: To use standard hopper on the MK100 auger, use lift arm mount bracket nearest intake end.

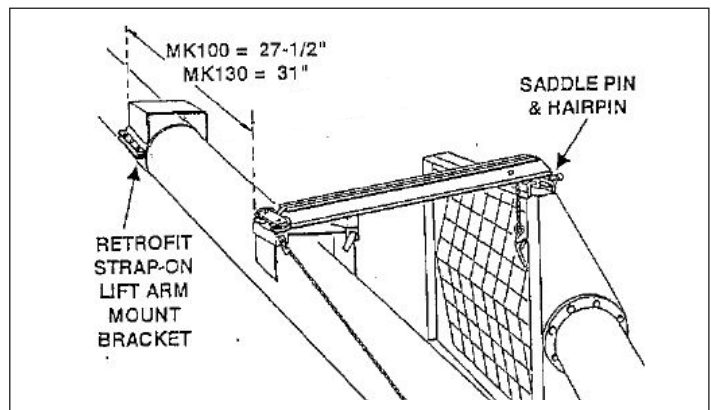

Figure No. 4

Part Number: 30827 R0
Revised: July 2018