

WESTFIELD

MK130 PLUS SPEED REDUCER KIT INSTALLATION, OPERATION, & SAFETY

We recommend that two or more people be present for this procedure.

Note: *In this manual, left hand and right hand directions are when you are looking at the boot from the tow bar end.*

TO PREPARE FOR SPEED REDUCER INSTALLATION:

Note: *When installing kit during assembly of a NEW auger, steps 1-8 may not apply.*

1. Lower auger to full down position.
2. Chock auger wheels to prevent rolling.
3. Remove tractor from auger.
4. Lower swing hopper fully to the ground.
5. Support auger boot securely with front end loader and strong sling or chain, or with block and tackle.
6. Remove swing hopper from auger boot.
7. Remove PTO driveline from auger.
8. Loosen bolts and nuts, remove PTO saddle bracket from boot.
9. Remove sprocket guard from boot.
10. Remove sprockets, bearing, and lock collar from boot.
11. Loosen bolts and nuts, remove bearings and washer from boot.

Note: *Don't remove the keys from the flighting or top gearbox shaft. Make sure there is nothing left on the front plate of the boot. See Figure 1.*

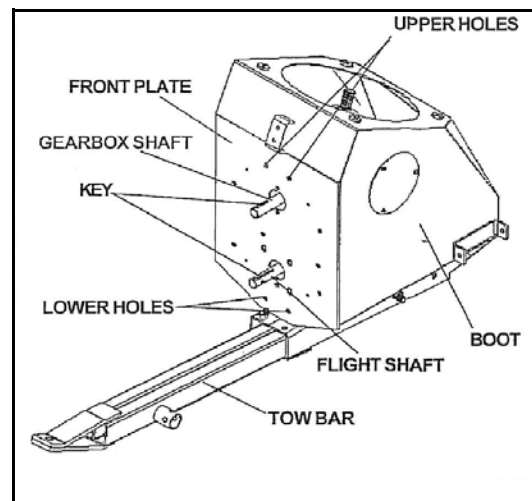

Figure 1



Flex Augers: Before beginning, make sure the roll pin is installed through the **correct hole** in the lower driveshaft as shown in Figure 2.

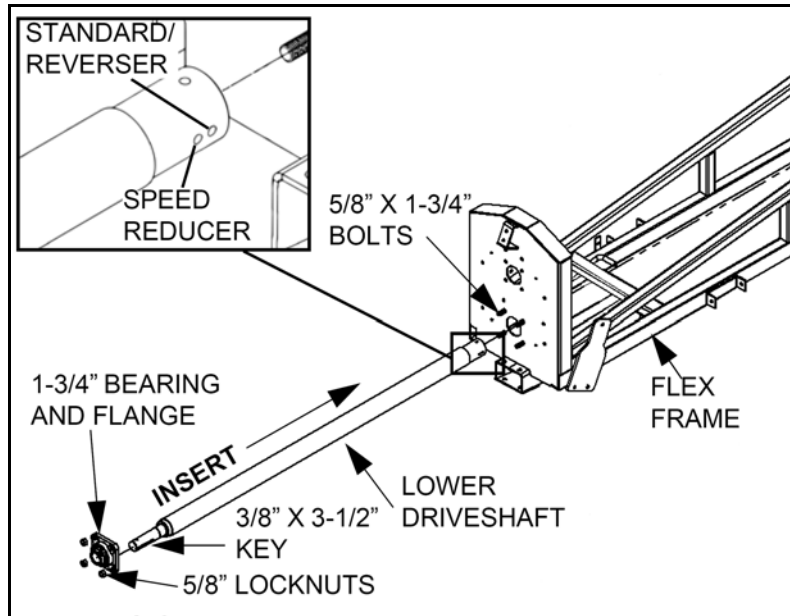

Figure 2

SPEED REDUCER INSTALLATION

See Figure 3, 4, and 5.

Note: The speed reducer gearbox has been filled at the factory (half full) with 75W90 synthetic oil (or equivalent). Before further installation, check oil level to make certain the gearbox is half full as required. Add oil if necessary. Do not use grease.

1. Face the flat side of the speed reducer gearbox to the front plate of boot. Slide the speed reducer gearbox onto flight shaft and gearbox shaft until the flat surface of the gearbox touches the front plate of boot. Make sure that the keys are in the right place between shafts and gearbox, and the mounting holes in the gearbox are lined up with the holes in the boot (Figure 3).
2. Using the upper and lower four holes on the front plate, connect gearbox and boot with four 1/2" x 7" mounting bolts and nuts. Use 1/2" washers between the gearbox and the boot on the upper two holes. Use the shim plate supplied between the gearbox and the boot on the lower two holes. Tighten bolts and nuts securely. Ensure nuts are tightened evenly and the reducer is seated tightly against the boot.
3. Insert 1-1/4" short plug shaft into the upper hole in the gearbox. Secure with a 5/16" x 3/4" set screw.

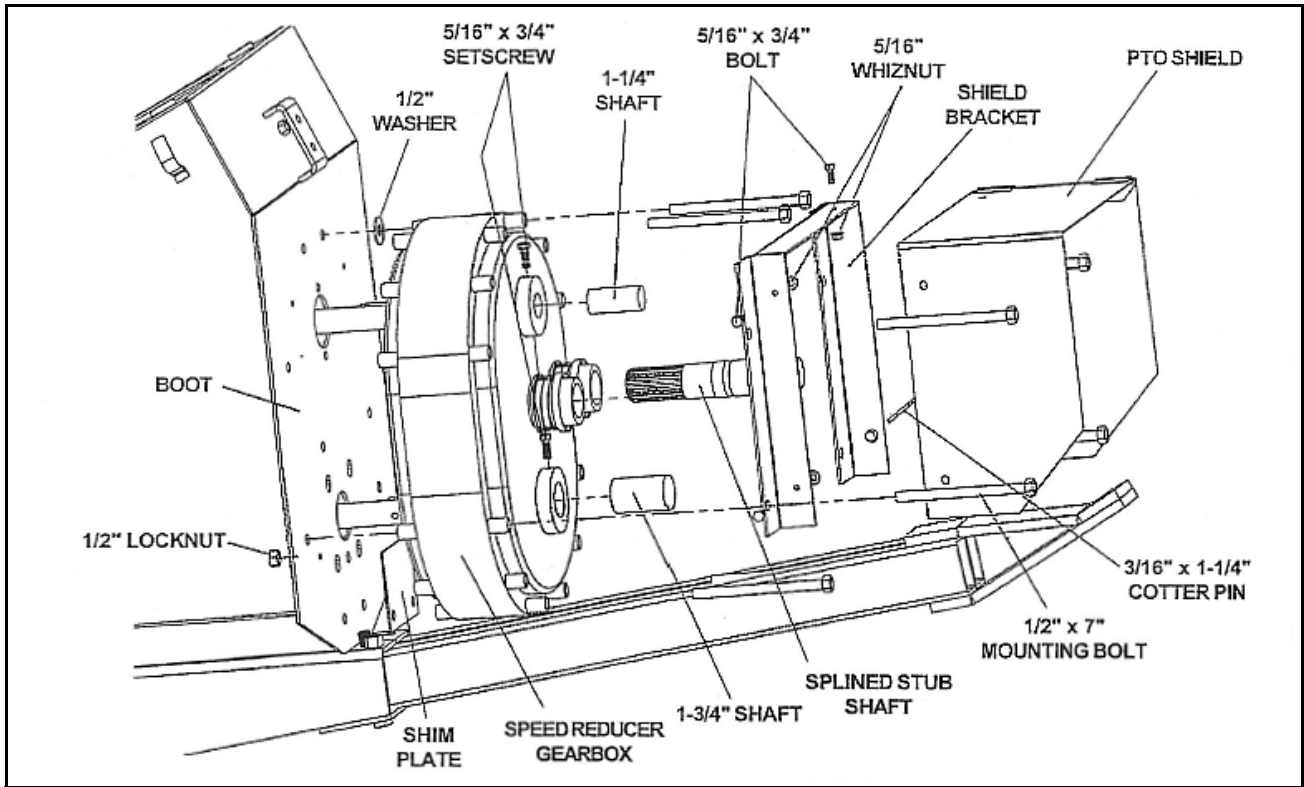

Figure 3

4. Insert 1-3/4" short plug shaft into the lower hole in the gearbox. Secure with a 5/16" x 3/4" set screw.

Note: For the model with set screws inside plug shafts, secure the set screws inside the shafts to gearbox.

5. Put the other four 1/2" x 7" mounting bolts through shield bracket, gearbox, and front plate. Use 1/2" washers between the gearbox and the boot. Connect bolts with 1/2" locknuts. Tighten bolts and nuts securely.
6. Install PTO shield onto shield bracket with three 5/16" x 3/4" bolts and nuts. Make sure that the lock pin on the bracket is through the hole on the right-hand side. Tighten bolts and nuts securely. Secure the right hand side shield with a 3/16" x 1-1/4" cotter pin.

WARNING



Missing Shield Hazard! To prevent serious injury or death, shut off and lock out power source and reattach shield before operating.

7. Attach PTO saddle extension bracket to boot with two 7/16" x 1-1/4" bolts and nuts. Tighten securely (Figure 4).

8. Reinstall the existing bracket and hydraulic hose holder to the extension with two 7/16" x 1-1/4" bolts and nuts. Tighten securely.

Note: *Before installing the hydraulic hose holder, you may have to drill the hole in the hose holder larger to fit a 7/16" bolt.*

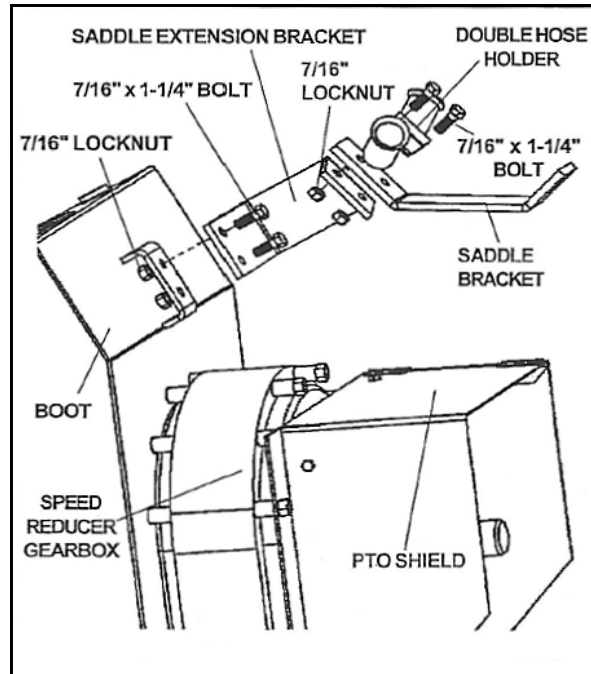

Figure 4

Note: *Support boot securely so that the tow bar can be repositioned.*

9. Loosen 5/8" locknut and remove the vertical 5/8" x 4-1/2" long bolt from tow bar. Loosen the 3/4" nut underneath the boot and remove the 3/4" x 6-1/2" long bolt out of the tow bar and boot channel. Slide the adjustable tow bar along boot channel until the hole in the tow bar lines up with the second hole in the boot channel (Figure 5).
10. Place a small spacer (provided) inside boot channel between tow bar and boot channel to fill the gap on the left. Insert the 3/4" x 6-1/2" long bolt back through the holes and spacer. Tighten bolt and locknut securely.
11. Insert the 5/8" x 4-1/2" long bolt and locknut back in the other hole vertically at the front of the boot. This bolt may have to be inserted from the bottom with the nut on top. Tighten both bolt and locknut securely.

Note: *In this case, the tow bar is extended out and pinned on an angle using the vertical bolt. Make sure the tractor PTO is lined up with the PTO connection on the gearbox.*

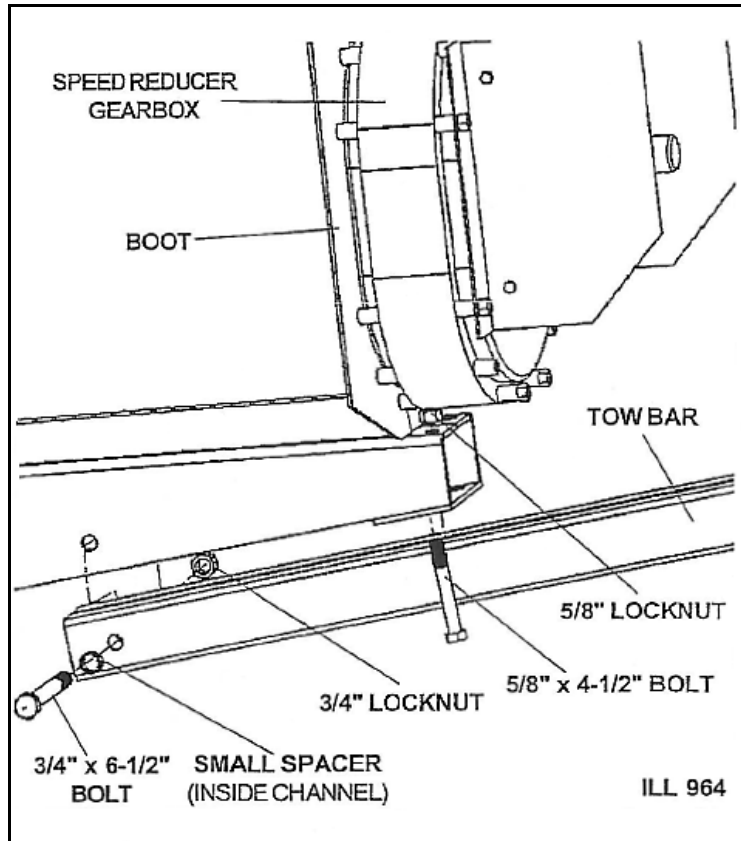

Figure 5

12. Re-install PTO driveline to splined stub shaft in the gearbox using existing 3/8" x 1-3/4" square key and 3/8" roll pin. **Tighten set-screws securely.**

CAUTION	
	<p>Protect your eyes when tapping in the roll pin.</p>

13. Replace swing hopper onto the boot. (Follow the assembly instructions in the MK130 PLUS Auger Manual.)
14. Remove the old PTO driveline from the tractor and replace with the new PTO driveline.
15. Remove chocks from the wheels.

OPERATING AND SAFETY INSTRUCTIONS

These are additional instructions; see Assembly & Operation Manual for full operating procedures and safety instructions. Read and understand all instructions before operating auger.

Before Operating, Ensure That:

1. The oil level in the speed reducer gearbox is adequate.
2. The PTO driveline is securely connected to the tractor and speed reducer gearbox.
3. All safety guards are in place and secured.
4. The PTO drive on the tractor is in the off position before starting tractor and the PTO hazard area is clear of all bystanders (Figure 6).

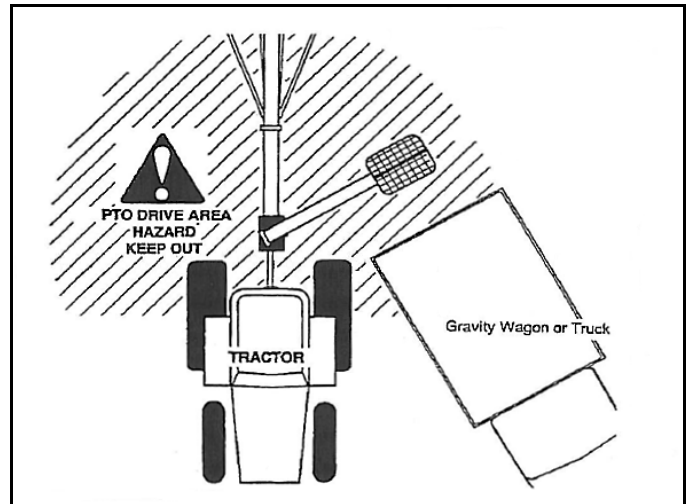

Figure 6

To Operate Auger Reverser (Figure 7)

1. Shut down tractor and remove ignition key. Set parking brake.
2. Pull out the cotter pin from lock pin on the shield. Fold up the right-hand side shield for easier access.
3. Pull back the collar on the spring collar locking system and pull out the splined stub shaft from the gearbox.
4. Pull back the collar on the other spring collar (reverse position) and insert spline shaft. Shaft is properly secured when collar springs back into place.

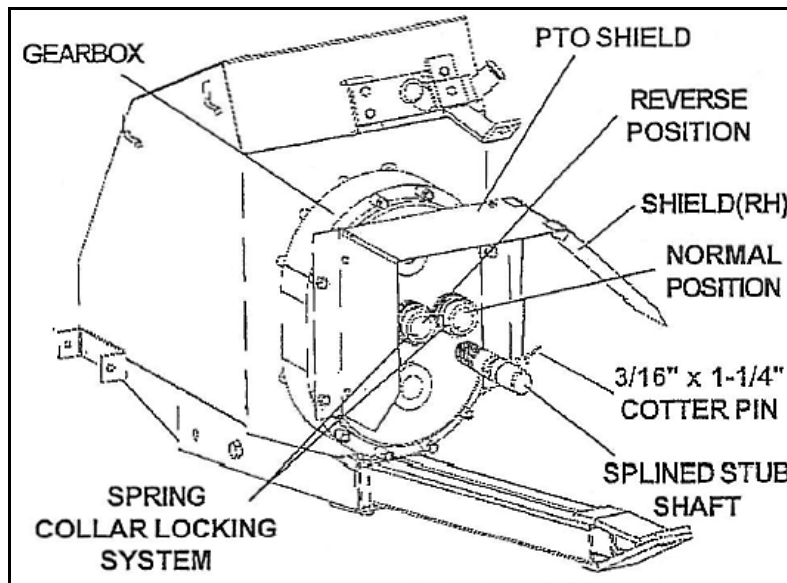



Figure 7

5. Fold down the right-hand side shield. Make sure that the cotter pin is reinstalled onto the shield.

WARNING	
	All safety shields must be in place and secured before operating.

6. Remove clean-out cover on the bottom of boot before operating in reverse mode. This allows excess material to exit the main auger tube.
7. Clear area of all personnel.
8. Operate auger slowly in reverse mode for a short period of time.
9. When boot is nearly full, shut off tractor and remove ignition key, then clean out grain from boot using a stick. Do not use hands.
10. Repeat steps 7-10 until auger obstruction is cleared.

CAUTION	
	<p>Shut down and lock out all power before emptying boot and before changing to forward or reverse modes.</p> <p>Ensure that PTO driveline is securely attached before operating. Keep body, hair, and clothing away from all moving parts, including PTO driveline.</p> <p>Do not exceed reverse operating speed of 100 rpm. Do not exceed forward operating speed of 540 rpm.</p>

WESTFIELD 

part of the Ag Growth International Inc. Group

ROSENORT, MANITOBA, CANADA R0G 1W0 PH:(866)467-7207 FAX:(866)768-4852
EMAIL:SALES@GRAINAUGERS.COM

AGI 
AG GROWTH INTERNATIONAL