

Series 14 & 19 Flat Bottom & Cone Mount – Pre 2020

Yellow Top Grain Bin Installation and Storage Instructions

Original Instructions

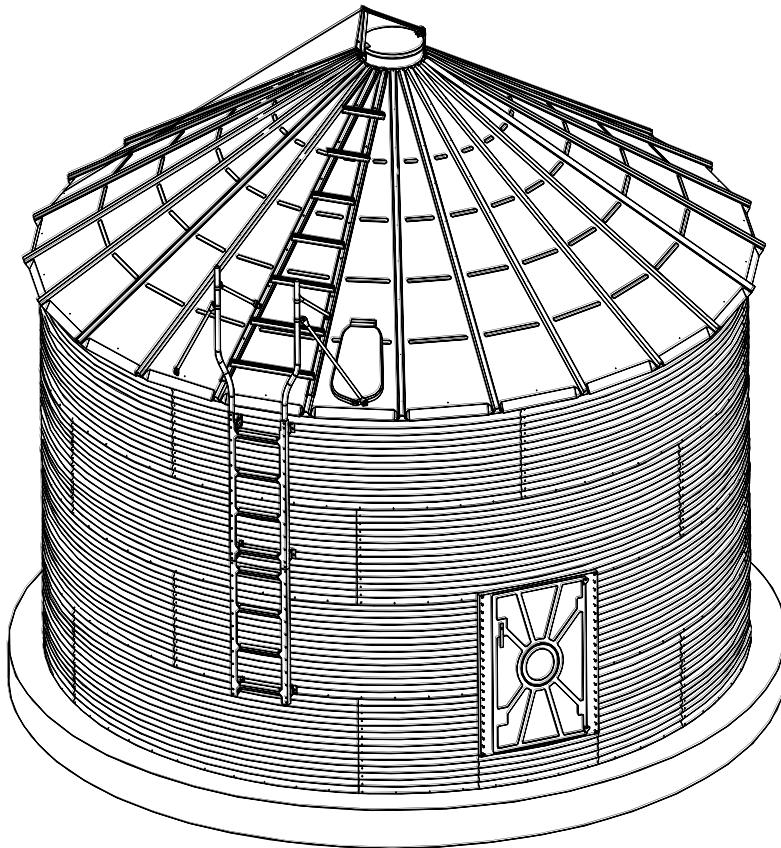

Read this manual before using product. Failure to follow instructions and safety precautions can result in serious injury, death, or property damage. Keep manual for future reference.

Part Number: 198818-2019 R0

Revised: October 2019

New in this Manual

The following changes have been made in this revision of the manual:

Description
Manual title, part number, and sidewall layout diagrams modified to reflect that this manual is limited to support for Pre-2020 sidewall layout designs. Post 2020 sidewall layout design is supported by manual "Series 14 & 19 Flat Bottom & Cone Mount – Post 2020" part number 198818 R30.

CONTENTS

- 1. Introduction 5**
- 2. Safety..... 6**
 - 2.1 Safety Alert Symbol and Signal Words..... 6
 - 2.2 General Safety 6
 - 2.3 Personal Protective Equipment..... 7
 - 2.4 Safety Decals 7
 - 2.5 Decal Installation/Replacement 7
 - 2.6 Safety Decal Locations and Details 8
- 3. Before You Begin 11**
 - 3.1 Bin Design and Capacity..... 11
 - 3.2 Foundation Design and Loads 11
 - 3.3 Site and Assembly 11
 - 3.4 Methods of Installation 12
 - 3.5 Cutting Openings in Wide-Corr® Grain Bins 12
 - 3.6 Critical Assembly Requirements 13
 - 3.7 Product Storage..... 14
 - 3.8 Grain Bin Use 15
 - 3.9 Important Notes..... 15
- 4. Preparation 17**
 - 4.1 Check Shipment..... 17
 - 4.2 List of Tools and Equipment..... 17
 - 4.3 Order Optional Equipment..... 17
 - 4.4 Site Selection 18
- 5. Assembly 19**
 - 5.1 Assembly Safety 19
 - 5.2 Foundations 20
 - 5.3 Assembly Procedure..... 22
 - 5.4 Bin Roundness 27
 - 5.5 Wall Sheet and Upright Layout..... 28
 - 5.5.1 Models 144 to 148 Flat Bottom Bins 28
 - 5.5.2 Models 144 to 148 Cone Mount Bins 33
 - 5.5.3 Models 194 to 198 Flat Bottom Bins 35
 - 5.5.4 Models 194 to 198 Cone Mount Bins 40
 - 5.6 Bottom Ring Angle and Upright Installation 41
 - 5.7 Two-Piece Upright Installation..... 43
 - 5.8 Upright Reinforcement Model 145 Cone Mount Bin 45
 - 5.9 Door Installation..... 47
 - 5.10 Auger Chute Assembly 49
 - 5.11 Bin to Hopper Cone Installation..... 52
- 6. Specifications 55**
 - 6.1 Capacity and Dimensions 55
- 7. Appendix 57**
 - 7.1 Materials List - Flat Bottom Bins 57
 - 7.2 Materials List - Cone Mount Bins..... 59
 - 7.3 Materials List - Hardware Pails & Door..... 61

7.4 Hardware Usage	62
7.5 Recommended Bolt Assembly	64
8. Limited Warranty: Westeel Grain Bin Products	65

1. Introduction

This manual describes how to assemble a Westeel Series 14 & 19 Flat Bottom & Cone Mount – Pre 2020.

Before assembling, please read this manual. Familiarize yourself with the process and the necessary precautions for efficient and safe assembly.

Everyone present at the assembly site is required to be familiar with all safety precautions.

Keep this manual available for frequent reference and review it with new personnel. Call your local distributor or dealer if you need assistance or additional information.

2. Safety

2.1. Safety Alert Symbol and Signal Words



This safety alert symbol indicates important safety messages in this manual. When you see this symbol, be alert to the possibility of injury or death, carefully read the message that follows, and inform others.

Signal Words: Note the use of the signal words **DANGER**, **WARNING**, **CAUTION**, and **NOTICE** with the safety messages. The appropriate signal word for each message has been selected using the definitions below as a guideline.



DANGER Indicates an imminently hazardous situation that, if not avoided, will result in serious injury or death.



WARNING Indicates a hazardous situation that, if not avoided, could result in serious injury or death.



CAUTION Indicates a hazardous situation that, if not avoided, may result in minor or moderate injury.



NOTICE Indicates a potentially hazardous situation that, if not avoided, may result in property damage.

2.2. General Safety

YOU are responsible for the **SAFE** assembly and installation of the grain bin. **YOU** must ensure that you and anyone else who is going to assemble/install the grain bin understands all procedures and related **SAFETY** information contained in this manual.

Remember, **YOU** are the key to safety. Good safety practices not only protect you, but also the people around you. Make these practices a working part of your safety program. All accidents can be avoided.

- It is the grain bin assembler and installation personnel's responsibility to read and understand **ALL** safety instructions, safety decals, and manuals and follow them when assembling, operating, or maintaining the equipment.
- Only experienced personnel who are familiar with this type of assembly and installation should perform this work. Untrained assemblers/installers expose themselves and bystanders to possible serious injury or death.
- Do not modify the grain bin in any way without written permission from the manufacturer. Unauthorized modification may impair the function and/or safety, and could affect the life of the grain bin. Any unauthorized modification of the grain bin will void the warranty.
- Follow a health and safety program for your worksite. Contact your local occupational health and safety organization for information.



2.3. Personal Protective Equipment

The following Personal Protective Equipment (PPE) should be worn when installing the equipment.

Safety Glasses

- Wear safety glasses at all times to protect eyes from debris.



Coveralls

- Wear coveralls to protect skin.



Hard Hat

- Wear a hard hat to help protect your head.



Steel-Toe Boots

- Wear steel-toe boots to protect feet from falling debris.



Work Gloves

- Wear work gloves to protect your hands from sharp and rough edges.



2.4. Safety Decals

- Keep safety decals clean and legible at all times.
- Replace safety decals that are missing or have become illegible. See decal location figures that follow.
- Replaced parts must display the same decal(s) as the original part.
- Replacement safety decals are available **free of charge** from your distributor, dealer, or factory as applicable.

2.5. Decal Installation/Replacement



1. Decal area must be clean and dry, with a temperature above 50°F (10°C).
2. Decide on the exact position before you remove the backing paper.
3. Align the decal over the specified area and carefully press the small portion with the exposed sticky backing in place.
4. Slowly peel back the remaining paper and carefully smooth the remaining portion of the decal in place.
5. Small air pockets can be pierced with a pin and smoothed out using the sign backing paper.

2.6. Safety Decal Locations and Details

Replicas of the safety decals that are attached to the grain bin and their messages are shown in the figure(s) that follow. Safe operation and use of the grain bin requires that you familiarize yourself with the various safety decals and the areas or particular functions that the decals apply to, as well as the safety precautions that must be taken to avoid serious injury, death, or damage.

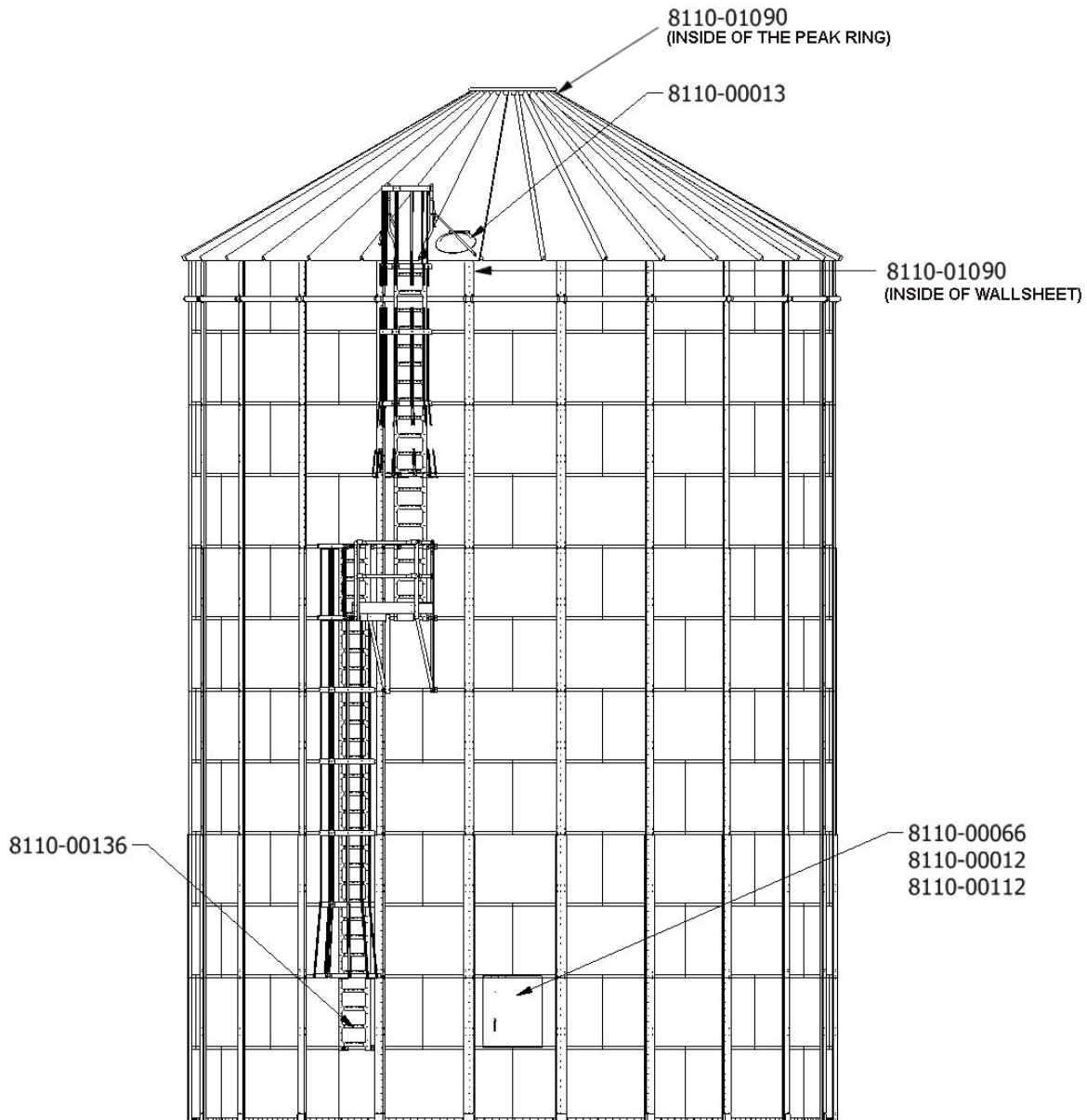
Figure 1. Safety Decals







 WARNING	
	
SAFETY INSTRUCTIONS	
<ul style="list-style-type: none"> • Read operator’s manual and all safety decals before assembling, using, or servicing bin. • Close/latch all access doors when not in use. • Do not alter or modify bin structure. • Replace any damaged components only with factory made components. • This bin should only be used to store free flowing, granular material, unless specifically designed and marked otherwise. • When filling, use top filler cap and direct material to center of bin. • Do not over-fill bin. Material should not be in contact with or place pressure on roof sheets. 	

Part Number: 8110–00012

 WARNING	
	
ENTRAPMENT HAZARD	
<p>Never enter the bin when loading or unloading grain.</p> <p>If you must enter the bin:</p> <ol style="list-style-type: none"> 1. Shut off and lock out all power. 2. Use a lifeline, safety harness, and have an observer outside before entering the bin. 3. Wear proper breathing equipment or a respirator. 4. Avoid the center of the bin. <p>Failure to heed these warnings could result in serious injury or death.</p>	

Part Number: 8110–00013

 WARNING		
		
Rotating flighting could kill or dismember.	Flowing material could trap and suffocate.	Crusted material could collapse and suffocate.
Keep clear of all augers. DO NOT ENTER this bin!		
<p>If you must enter the bin:</p> <ol style="list-style-type: none"> 1. Shut off and lock out all power. 2. Use a safety harness and safety line. 3. Station another person outside the bin. 4. Avoid the center of the bin. 5. Wear proper breathing equipment or respirator. <p>Failure to heed these warnings could result in serious injury or death.</p>		

Part Number: 8110–00112

WARNING



FALLING HAZARD

To prevent serious injury or death:

- Do not climb ladder if damaged, wet, icy, greasy, or slippery.
- Maintain good balance by having at least three points of contact at all times.

Part Number: 8110-00136

NOTICE

When equipped with aeration system, to prevent roof and/or bin damage:

- Use a minimum 1 square foot (0.1m²) opening for each 1000ft³/min (30m³/min) of air.
- Ensure all roof vents are open and unobstructed.
- Discontinue use of aeration fan if roof vents become obstructed with ice.

Part Number: 8110-00066



**FALL RESTRAINT
ANCHOR POINT
MAX WORKING LOAD:
1,000 lb [453 kg]**

SEE MANUFACTURER ROOF MANUAL FOR
DETAILED INSTRUCTIONS REGARDING
ANCHOR POINT LOCATIONS

Part Number: 8110-01090

3. Before You Begin

3.1. Bin Design and Capacity

These Westeel Grain Bins are designed for:

1. Non-corrosive free-flowing materials up to 55 lbs/ft³ (880 kg/m³) average compacted bulk density.
2. Maximum horizontal gusted wind speed of 94 mph (151 km/h)
3. Seismic zone 2a (U.B.C. 1997).
4. Roof Loading

Snow Load		Peak Load			
		15' – 24' bins		27' – 48' bins	
Imperial	Metric	Imperial	Metric	Imperial	Metric
15.0 lbs/ft ²	.72 kPa	4000 lbs.	17.8 kN	5000 lbs.	22.2 kN
24.0 lbs/ft ² (when optional roof stiffening rings installed)	1.15 kPa (when optional roof stiffening rings installed)				

3.2. Foundation Design and Loads

The foundations for the stiffened bin models are based on 4000 lbs. per sq. ft. (192 kPa) soil bearing capacity. All foundation designs use 3000 lbs. per sq. in. (21 MPa) ultimate compressive strength (after 28 days) for concrete and 43,500 lbs. per sq. in. (300 MPa) re-bar. The foundation designs included in this manual are suggestions only, and will vary according to local soil conditions. Westeel will not assume any liability for results arising from their use.

Important

Foundation should be uniform and level. Level should not vary by more than ¼" over a span of four feet under the bottom ring angle. Any variance from level must be shimmed under upright base assembly. If being utilized to support a full floor aeration system, this levelness requirement should extend across the complete floor area.

3.3. Site and Assembly

Unless otherwise specifically provided in writing, Westeel does not take responsibility for any defects or damages to any property, or injury to any persons, arising from or related to any site or assembly considerations, including but not limited to:

- Bin location and bin siting
- Soil conditions and corresponding foundation requirements (note that the examples provided in manuals are for specifically stated soil conditions)
- Bin assembly (Westeel recommends the use of qualified bin installers; contact Westeel for information on installers in your area)
- Field modifications or equipment additions that affect the bin structure
- Interconnections with neighboring structures

- Compliance with all applicable safety standards, including but not limited to fall restraint systems (ladders or other systems). Local safety authorities should be contacted as standards vary between jurisdictions.

3.4. Methods of Installation

The recommendations for assembling and installing Westeel grain bins must be closely followed to achieve the full strength of the bin and to achieve adequate weather sealing. The product warranty is void if:

1. Wall sheets and/or uprights not specified for a given tier are used.
2. Foundations are found to be inadequate or out-of-level.
3. Anchor bolts (cast-in-place, drill-in, chemical type or other) are found to be inadequate.
4. Off-center loading or unloading is used. (This does not apply to the use of approved side unloading systems.)
5. Materials stored are not free-flowing or have a compacted bulk density greater than 55 lbs/ft³ (880 kg/m³).

If using bin jacks during assembly, always lift on an upright. Choose a hoist with a adequate capacity for the expected empty bin deadload. Make sure the rated capacity of the hoist is not exceeded.

3.5. Cutting Openings in Wide-Corr® Grain Bins

This section provides instructions for cutting openings to accommodate fan transitions, unloading augers and roof vents.

General Rules for Cutting openings

1. Never cut any uprights, roof ribs, or wall sheet bolted vertical seams to create an opening.
2. Openings shall be located so equipment being installed won't interfere with any bin components/accessories.
3. Openings shall be minimized as much as possible for structural integrity of grain bins.
4. Corners in openings shall be cut with minimum radius of 1/8" to reduce stress concentration.
5. Openings shall be sealed all the way around for all weather conditions.
6. Instructions shall be followed closely to avoid damage to bin structure.
7. Except cutting openings described below, any other modification to Westeel bins shall be approved by a professional engineer.

Openings for Fan Transitions of Aeration Floors

1. Consult aeration floor installation instructions for information on Planning floor layout.
2. Openings shall be centered to a wall sheet in horizontal direction.
3. Opening shall be cut as tight as it can be for the transition to go through and shall have no more than 1/4" gap on any side to the section of a fan transition going through a bin wall.
4. Opening height for fan transition shall be limited to 12.5" inches from bottom edge of a bottom wall sheet.
5. Opening width shall not exceed 46.5" for stiffened bins and 72.5" for unstiffened bins.
6. Vertical support shall be required to support load above opening.
7. Bottom angles may be cut flush to the sides of an opening to form part of opening.

Openings for Unloading Augers of Wide-Corr® Bins with Full Floor Aeration

1. Consult aeration floor installation instructions for information on Planning floor layout.
2. Openings shall be centered to a wall sheet in horizontal direction.
3. Openings shall be cut as tight as it can be for unloading auger to go through and shall have no more than 1/4" gap to auger flange section on any side.
4. Opening height for any auger shall be limited to 12.5" from the bottom edge of a bottom wall sheet.
5. Vertical flange of a bottom angle may be cut flush to sides of an opening to form part of opening.

Openings for Roof Vents in Roof Sheets

1. Openings shall be centered between roof ribs and have 2.5" minimum distance between edge of opening and base of a roof rib.
2. Openings can be square, rectangular, or round.
3. Openings shall be the same size as the inlet opening of a vent being installed.
4. Any side of a square/rectangular opening shall have a maximum length of 18" and a circular opening shall have a maximum diameter of 24".

3.6. Critical Assembly Requirements

To ensure a successful, safe and reliable outcome you must comply with the following assembly techniques and practices:

1. Comply with all local code and jurisdictional requirements applicable to your grain bin installation.
2. Design and build foundations with the necessary strength for the loads they must support, and for local soil conditions. Westeel foundation guidelines are based on specific stated conditions and may not be applicable to local conditions.
3. Your foundation must provide uniform and level support to the structure being supported. Surface imperfections causing gapping must be remedied. This may involve, but not be limited to a) grouting under the bottom ring of a non-stiffened bin or tank, and b) shimming under the uprights of a stiffened bin or tank, or under the legs of a hopper.
4. Make sure that the proper hardware is utilized for all bolted connections. If a shortage occurs, do not substitute. Take the necessary steps to obtain the proper hardware. Make sure nuts are tightened to the required torque values as specified in the appropriate assembly manual.
5. Comply with all assembly instructions provided in the appropriate assembly manual to make sure your whole grain bin is constructed safely. **Important: Do not deviate from the wall sheet and upright layouts provided.**
6. Before anchoring your structure to its foundation, make sure the structure is round. The maximum variation from perfect roundness is 3/4" on the radius. Locate anchor bolts toward the outside of the anchor bolt holes (away from the circle) to permit the incremental expansion that can occur with the initial filling.
7. When installing roof stiffening rings, if it is necessary to shorten the stiffening ring tubes, shorten them as little as possible. Initially the nuts on the expanders should be centered and as close together as possible. When tightening, share the amount of take-up between expanders such that the nuts remain centered, and the amount of engagement between all expanders on the same ring is equalized.
8. If extending an existing bin or tank, ensure that the foundation is adequate for the increased loads it must support.

9. If installing an existing bin on a hopper, make sure the bin is designed for a hopper application, and that the foundation is capable of withstanding the substantial point loads that the hopper legs apply. If uprights are present, make sure that they are supported.
10. Make sure that an integral end-to-end connection exists between all mating uprights. Successive uprights must not overlap.
11. Vertical tolerances between uprights and wall sheets are tight. This can be affected by “jacking” techniques, which can allow the tolerance to grow or shrink depending on the technique used. The gapping between successive uprights must be monitored to ensure that upright holes align with wall sheet holes.
12. If catwalks are being installed on the structure, upright catwalk upgrades are likely required. The upgraded stiffeners must be installed in the correct locations to support the intended catwalk loads. Also, the structure must be properly oriented to ensure the eventual correct alignment between the catwalks and the supporting uprights. Finally, the connectors that tie into the uprights and support the catwalks are best installed during assembly of the structure. See the catwalk assembly manual for additional details.

3.7. Product Storage

Rust on Galvanized Parts

1. White rust forms when moisture is allowed to collect on galvanized surfaces that have yet to develop the durable zinc oxide layer. This zinc oxide layer naturally occurs as the surface interacts with carbon dioxide, and is characterized over time by the dull grey appearance that weathered galvanized surfaces get.
2. Parts that are not well ventilated or well drained can collect water between surfaces and develop white rust.
3. White rust is not a structural concern if its development is stopped in the early stages. A light film or powdery residue can occur after a period of heavy rainfall or a short time of improper storage. If white rust has started to develop, separate parts and wipe off any moisture. Next, using a clean cloth, apply a thin layer of petroleum jelly or food-grade oil to the entire part.
4. If moisture is left on parts, this white rust can become more aggressive and turn into red rust. Red rust can cause degradation in the material and become a structural concern. Any parts that have red rust should be replaced immediately.

Storage Guidelines

- Keep all bundles dry before assembly of the bin.
- Start assembly as soon as possible.
- Do not lay bundles on the bare ground. Raise all bundles 6" to 8" off the ground on wood blocks or timbers. (See Detail A in [Figure 2 on page 15.](#))
- Store curved wall sheets ‘hump-up’. (See Detail A in [Figure 2 on page 15.](#))
- All other bundles material should be placed so that they are well sloped to promote good drainage. (See Detail B in [Figure 2 on page 15.](#))
- Roof sheets must be elevated at least 12" at the small end of the sheets. (See Detail B in [Figure 2 on page 15.](#))
- Temporary storage can be provided by erecting a simple framework supporting a waterproof tarp. (See Detail C in [Figure 2 on page 15.](#))
- All bin boxes, ladder boxes and hardware boxes should be stored inside. These are not waterproof, and will deteriorate in normal weather conditions, allowing moisture to contact the parts inside.

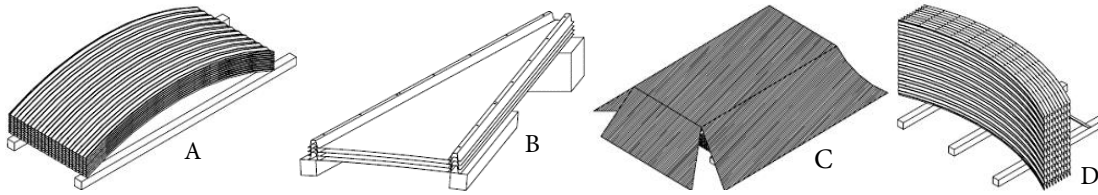
Figure 2. Product Storage**If Parts Become Wet**

1. If parts become submerged or wet, the bundles should be opened as soon as possible, sheets or material separated and dried. Keep separated until assembly.

Brace parts properly so as to avoid damage or injury from material falling when in storage. (See Detail D in [Figure 2 on page 15.](#))

2. Any boxed parts that become wet should be dried and stored in a new box that is free of moisture.
3. In addition to wiping down wall sheets, a food-grade oil can also be applied with a clean, lint-free cloth. This will assist in preventing any further moisture from contacting the galvanizing on the steel. Due to safety concerns with installation and use, Westeel does not recommend the use of oil on other parts such as roof sheets and safety ladders.

3.8. Grain Bin Use

- Do not off-center unload a grain bin. It is imperative to unload from the center of the bin first, until as much grain as possible has been removed, and only then proceed to unload from the next closest unload gate to the center. Continue utilizing the unload gates in succession from the center towards the outside. Gate control mechanisms should be clearly marked and interconnected to prevent an external gate from being opened first.
- The only exception to center unloading is when a properly designed and installed side draw system is utilized. However, as bins tend to go out of round when employing side draws, the bin must be completely emptied before refilling.
- When unloading a bin with a mobile auger through a properly designed auger chute, the entry end of the auger should be pushed into the center of the bin before the auger is engaged. Slower rates of flow are preferable and should not exceed the capacity of an 8" auger.
- Ensure that the inner door panels of grain bin doors are completely closed and latched before filling the grain bin.
- Never enter a loaded grain bin for any reason. Grain can be a killer.

3.9. Important Notes

- Westeel does not provide a foundation design for this product, and is not liable for any damages or injuries related to inadequately designed or constructed foundations. Customers must contract professional services for all foundation design and construction work.
- In order to maintain your wall sheets in good condition separate sheets and allow air circulation between them. Store sheets in a dry place. Do not store sheets with sheet ends pointing upwards.
- To keep an even pressure on walls, the bin must always be unloaded from the centre.
- Contact local power officials for minimum power line clearance.

- See [Section 3.6 – Critical Assembly Requirements on page 13](#) for mandatory siting and assembly requirements.
- Store only non-corrosive, free-flowing materials up to 55 lbs/ft³ (880 kg/m³) average compacted density in Westeel bins.
- Tighten all bolts to the recommended torque settings.
- Do not locate grain bins close to high buildings, which might cause snow to fall onto or build up on the roof of the grain bin. Consider future expansion and allow space for loading and unloading of the bin. Your dealer and local government agricultural consultants can help you plan your storage system for maximum efficiency.

4. Preparation

4.1. Check Shipment

Unload the parts at the assembly site and compare the packing slip to the shipment. Ensure that all items have arrived and that none are damaged.

Report damaged parts or shortages immediately to the delivering carrier, followed by a confirming letter requesting inspection by the carrier, if required. Order any replacement parts immediately to ensure that assembly will not be held up by missing parts. All parts will be charged for and credit will be issued by party at fault. No credit will be issued if freight bills are signed as received in good condition.

4.2. List of Tools and Equipment

Use quality tools and equipment. Use them safely, and correctly, for their intended use. Tools for this application should include:

Tools

- Electric or pneumatic (air) impact tools
- Power drill and drill bits
- Sockets (multiple 9/16" and 1/2" sockets recommended)
- Large-pocket carpenter pouch
- 8" (20 cm) metal punches (for aligning bolt holes)
- Step and extension ladders, construction grade
- 6-point wrenches (Imperial, box end)
- Metal-cutting saw suitable for cutting roof rings and wind rings
- Scaffolding
- Centre-post bin stand
- Crane and/or bin jacks

Minimum Recommended Safety Equipment

- A properly-stocked first-aid kit
- Eye, foot, head, and hand protection (safety glasses, steel-toed boots, hard hat, work gloves)
- Cable, chain, or rope to tie-off bin or jacks in case of wind
- Body harness and lifeline (for use where falling hazard exists)
- Ground fault interrupt protected electrical hook-ups

4.3. Order Optional Equipment

Optional equipment such as unloading augers, aeration equipment, anchor bolts, foundation sealant, external ladders, safety cage and platforms, etc., should all be on site and checked before assembly starts. Plan your installation in advance. For details, see assembly instruction supplied with optional equipment.

4.4. Site Selection

Choose a firm, level, well drained site with access for loading and unloading equipment. Remove all top soil and organic or loose material. Foundation designs shown are based on minimum soil bearing capacity of 2,000 psf (96 kPa) for Series 14 and 2,500 psf (120 kPa) for Series 19. If soil bearing capacity is unknown, consult a local engineer or soil specialist. See Foundation details on pages 13 & 14. Top soil does **not** provide adequate strength to support grain bins.

Do not locate grain bin close to high buildings which will cause snow to fall onto or build up on the roof of the grain bin. Consider future expansion and allow space for loading and unloading of the bin. Your Westeel dealer and local government agricultural consultants can help you plan your storage system for maximum efficiency.

5. Assembly



Before continuing, ensure you have completely read and understood this manual's Safety section, in addition to the safety information in the section(s) below.

5.1. Assembly Safety

WARNING

- Do not take chances with safety. The components can be large, heavy, and hard to handle. Always use the proper tools, rated lifting equipment, and lifting points for the job.
- Carry out assembly in a large open area with a level surface.
- Always have two or more people assembling the grain bin.
- Make sure you have sufficient lighting for the work area.
- Tighten all fasteners according to their specifications. Do not replace or substitute bolts, nuts, or other hardware that is of lesser quality than the hardware supplied by the manufacturer.
- Stay away from overhead power lines and other obstructions during assembly. Contact with power lines can cause electrocution.
- Do not work in high winds.

5.2. Foundations

Figure 3. Details for various types of foundations

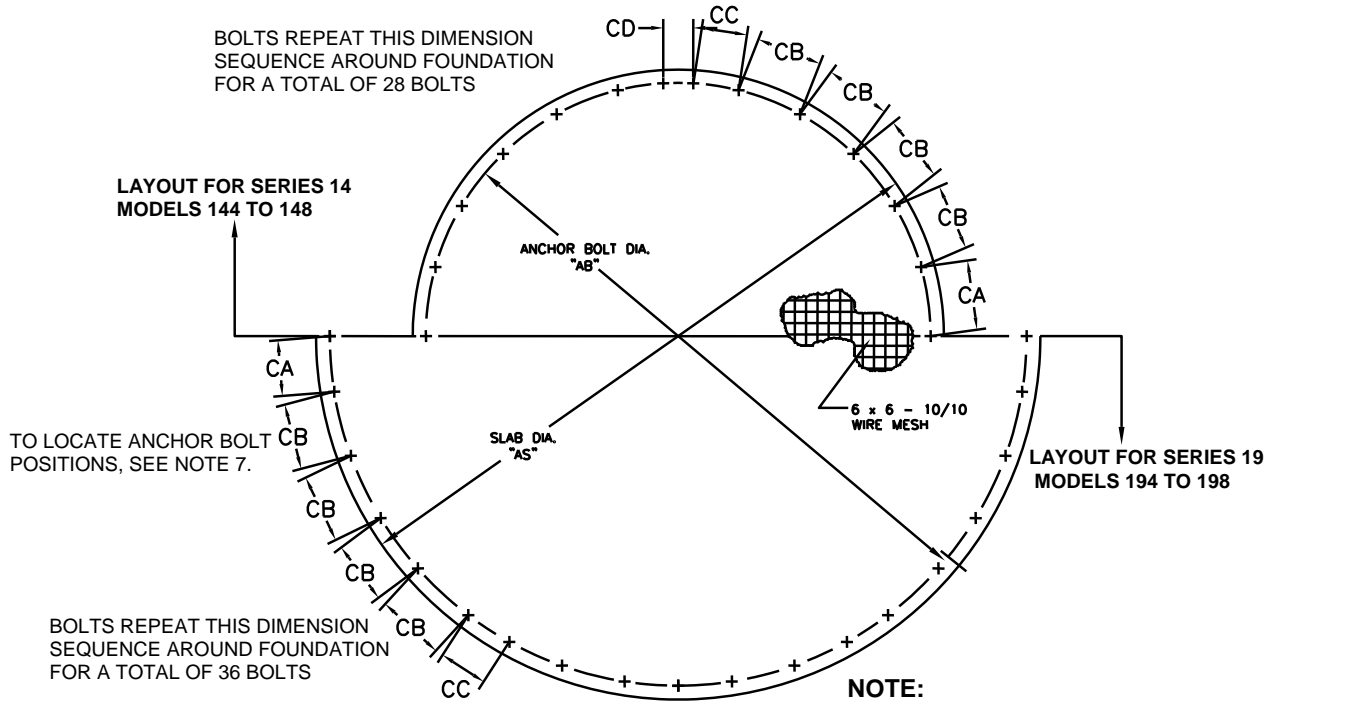

NOTE:
Several foundation options are shown below. For best results, use Westeel "SEALFORM" foundation kits. See your Westeel dealer for details.

TYPE "A"
CURB FOOTING / FLOATING SLAB
Recommended for most soil conditions

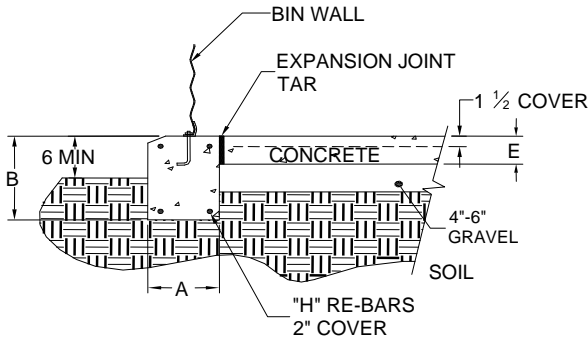

TYPE "B"
SINGLE POUR

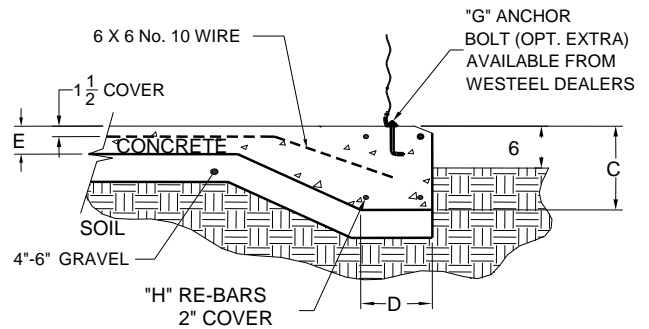

TYPE "C"
FLOATING SLAB DETAIL

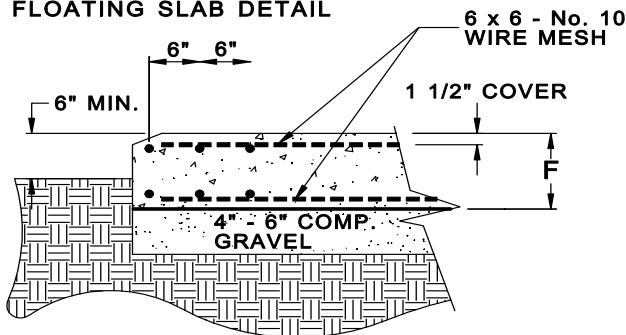

TYPE "C"
FLOATING SLAB

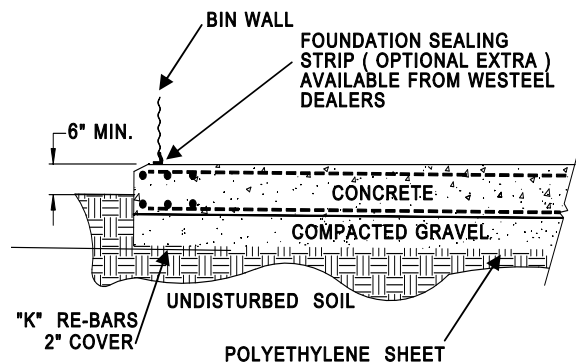

Note

1. Use concrete with minimum 28 day compressive strength of 2,500 psi (17 MPa)
2. Remove all top soil, and any loose or organic material.
3. Sub soil should be checked for bearing strength 2,500 psf (120 kPa) minimum for all models.
4. Use coarse gravel fill to level the site only if excavation is not practical. Be sure to thoroughly compact all fill.
5. Chamfer outside edge of concrete to ensure that water drains off freely.
6. Slope site to ensure water is free to run away from the grain bin even with build up of snow and ice.
7. The bottom ring angle and one tier of sheets can be used to locate the anchor bolts.

Table 1. Anchor Bolt Spacings

See [Figure 3 on page 20](#)

CHORD	CA	18-7/16"
	CB	21-13/16"
	CC	15-1/8"
	CD	10-1/16"

Table 2. Foundation Dimensions Table

See [Figure 3 on page 20](#)

DIMENSIONS	BIN MODEL				
	144 & 145	146	147 & 148	194 TO 196	197 & 198
A	8"	12"	15"	8"	12"
B	12"	12"	12"	12"	12"
C	12"	12"	12"	12"	18"
D	8"	12"	12"	8"	8"
E	4"	4"	4"	6"	6"
F	8"	8"	10"	10"	10"
G	28"	28"	28"	36"	36"
AB	167-1/4"	167-1/4"	167-1/4"	230-7/8"	230-7/8"
AS	176"	180"	180"	240"	240"

Table 3. Concrete Requirements in yd³ (m³)

FOUNDATION "A"	3.0 (2.3)	3.5 (2.7)	4.0 (3.1)	7.5 (5.7)	8.5 (6.5)
FOUNDATION "B"	3.5 (2.7)	4.0 (3.1)	4.0 (3.1)	7.5 (5.7)	9.5 (7.3)
FOUNDATION "C"	4.5 (3.5)	4.5 (3.5)	5.5 (4.2)	10 (7.7)	10 (7.7)

Table 4. Re-Bar & Wire Mesh Requirements

H	NO. & SIZE	4 - #3 Re-bar	4 - #3 Re-bar	4 - #3 Re-bar	4 - #3 Re-bar	4 - #3 Re-bar
	QUANTITY	200' (75 lbs)	200' (75 lbs)	200' (75 lbs)	280' (106 lbs)	280' (106 lbs)
K	NO. & SIZE	4 - #3 Re-bar	4 - #3 Re-bar	6 - #3 Re-bar	6 - #3 Re-bar	6 - #3 Re-bar
	QUANTITY	200' (75 lbs)	200' (75 lbs)	280' (106 lbs)	400' (150 lbs)	400' (150 lbs)
WIRE MESH **		169 sq. ft.	176 sq. ft.	176 sq. ft.	314 sq. ft.	314 sq. ft.

* Concrete requirements shown are based on exact dimensions. Order slightly more to avoid shortages.

** Wire mesh quantity is doubled when Foundation Type C is used.

5.3. Assembly Procedure

1. Material Receiving

- a. Unload bin parts near the foundation.
- b. Locate items in order of their assembly.

For Materials Lists, see [Section 7. – Appendix on page 57](#).

2. Bin Lifting

- a. Use of a bin crane is recommended for lifting your bin. Pole jacks or bin jacks may also be used.
- b. Ensure that rated capacity of all lifting devices exceeds the maximum bin weight.
- c. If using a crane, lift using a round support or tripod inside the bin directly under the vent collar.

3. Roof Assembly

- a. Using 3/8" x 3/4" bolts and 3/8" nuts, assemble the top tier of wall sheets, referring to:
 - [Figure 4 on page 23](#)
 - [Table 5 on page 23](#)
 - [Section 5.5 – Wall Sheet and Upright Layout on page 28](#)

Figure 4. Roof Assembly Detail

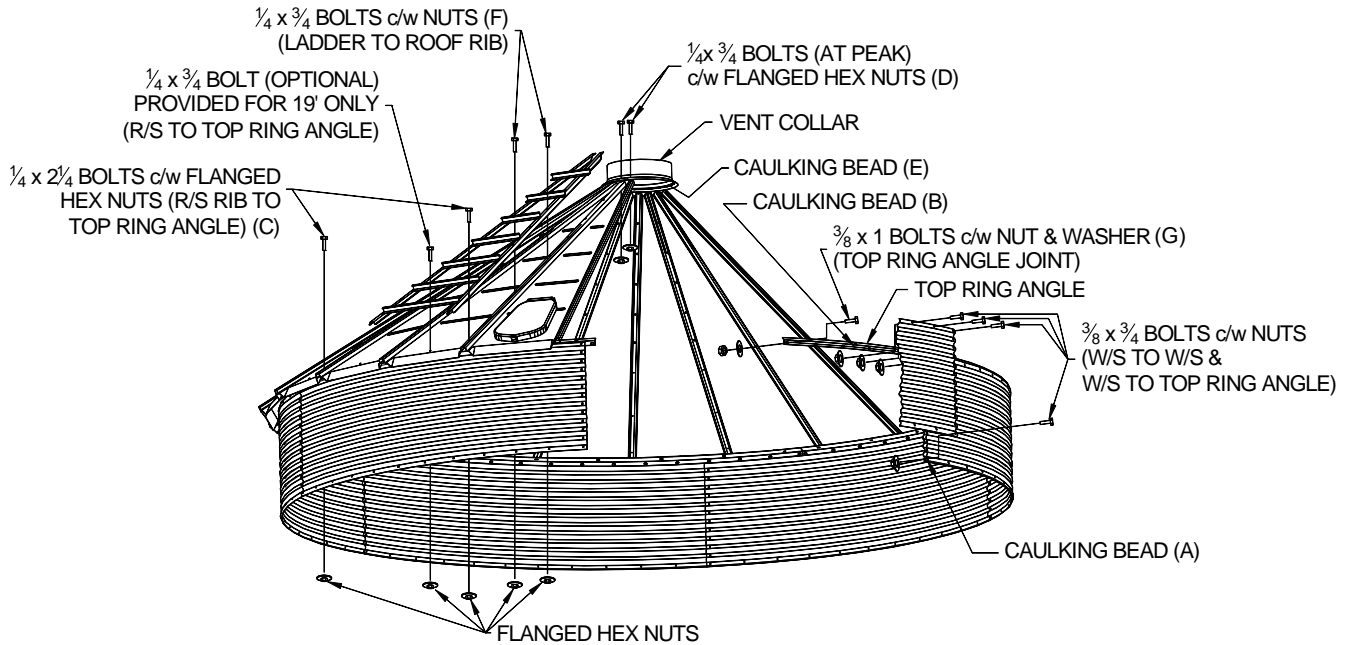

Table 5. Roof Parts

DESCRIPTION	ROOF SHEET	ROOF M/H SHEET	TOP ANGLE	VENT ASSEMBLY	LADDER	M/H BULB GASKET	EAVES CLOSURE
P/N for 14' BIN	235601	235613	236123	236060	235615	235623	235651
P/N for 19' BIN	235602	235614	236223	236060	235616	235623	235652

- b. Caulk the vertical seams. (See A in [Figure 4 on page 23.](#))

Note

Careful use of drift pins will ease assembly.

Do not tighten any nuts throughout the entire roof assembly until after all roof sheets are in place (unless otherwise specified).

- c. Attach the top ring angles to the top corrugation of the top tier of wall sheets.
- Start the first angle in the centre of a wall sheet.
 - Overlap the angles by two bolt holes.
 - Use 3/8" x 1" bolts and washers at the two overlapped holes only. (See G in [Figure 4 on page 23.](#))
- d. Apply 6" of caulking to the top ring angle laps (See B in [Figure 4 on page 23.](#))
- e. Make the bin as round as possible.
- f. Caulk the underside of the vent collar (See E in [Figure 4 on page 23.](#))
- g. Place the roof sheet with manhole and a regular roof sheet on the top ring angle and under the vent assembly, to shed water.

Roof sheets have a large rib and a small rib for nesting.

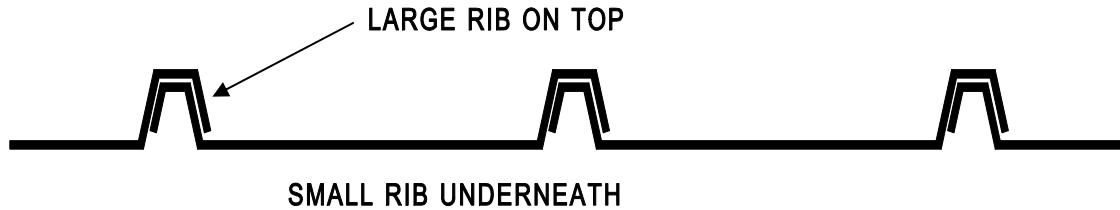
Figure 5. Nesting roof sheets

- h. Place the large rib on top.
- i. Make sure the manhole and the roof ladder are adjacent to one another and located to match conveniently with a wall ladder.
For this reason, the manhole is not normally located directly over the door. The manhole may be located on either side of the roof ladder.
- j. Position the vent assembly with the latch at ninety degrees to the roof sheet on which the roof ladder will be located.
- k. Install a 1/4" x 2-1/4" bolt through the common hole of the roof sheets, the roof ladder and the top ring angle at the eaves (See C in [Figure 4 on page 23.](#))
 - Use 1/4" x 2-1/4" bolts for all roof rib / top ring angle connections.
 - Use a 1/4" flange hex nut on the inside of the top ring angle.
 - Install one 1/4" x 3/4" bolt at the vent cap using a 1/4" flanged hex nut. (See D in [Figure 4 on page 23.](#))
 - Install 1/4" x 3/4" bolts using regular 1/4" hex nuts along the roof ribs (See F in [Figure 4 on page 23.](#))
- l. Install the remaining roof sheets in a similar fashion.

For the 19' bin, an extra bolt is provided for the bottom centre of each roof sheet. If the connection is desired, mark the sheet from inside through the top angle and punch a hole from outside.

Note

Roof sheet with inspection hatch is normally adjacent to the roof ladder.

Note

It may be necessary to slide the ring of wall sheets in or out, or to raise or lower the vent assembly to get the vent to sit horizontally and in the best location for the erection of the remainder of the roof sheets. If the weight of the roof tips the vent assembly too much, a sheet or two on the opposite side can be installed to balance the load

- m. After all roof sheets are in place, tighten the nuts around the vent collar.
- n. If ventilation is not required, the roof may be sealed off by inserting eaves closures from the inside of the bin between the top ring angle and roof rib. (See [Figure 6 on page 25.](#))

Figure 6. Plastic Eaves Closure

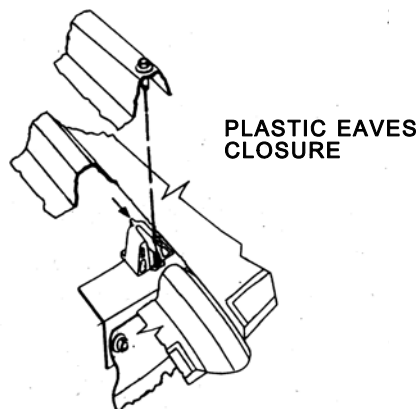

- o. Tighten nuts at the eaves after inserting closures.
- p. Tighten remaining nuts along roof ribs and in wall sheets using recommended torque.
- q. Attach bulb gasket to lip of manhole. (See [Figure 7 on page 25.](#))

Figure 7. Manhole Gasket

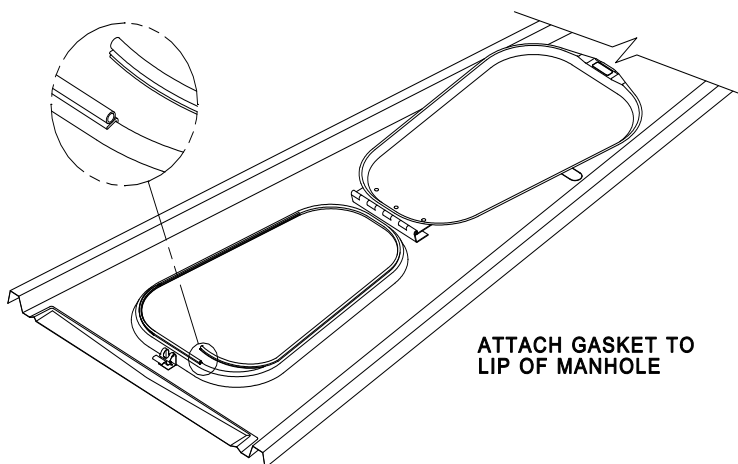

To operate the roof manhole:

- Use thumb pressure in the position shown. (Edge or butt of hand also works well.)

Figure 8. Operating the roof manhole

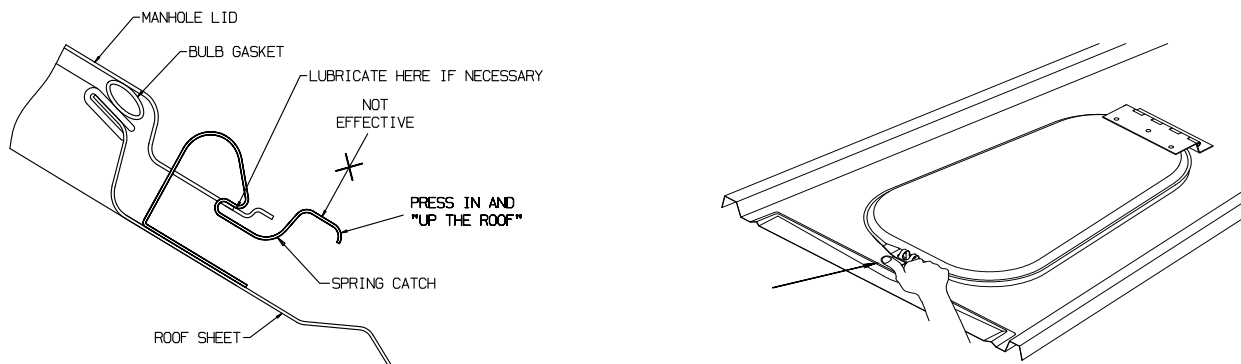

- Press towards lid for easy "pop-up" release.

Pushing the spring in helps the lip of the cover to clear the "nose" of the spring. The force of the compressed gasket helps get the manhole cover off the catch. (Manhole is more difficult to open without a bulb gasket in place.)

- Apply a small amount of lubrication on the "nose" of the spring catch as shown to reduce the friction of the cover as it slides over the catch. WD40 or equivalent will work without attracting dust.

4. Wall Sheet Assembly

- Assemble the wall sheets as shown in [Figure 4 on page 23](#) and described [Section 5.5 – Wall Sheet and Upright Layout on page 28](#).
- When using lifting jacks, locate the jacks as close to the bin sheets as possible. The jacks should not pull the sheets inward or outward. Tighten the bolts on the vertical seams before lifting with the jacks.
- To shed water on the outside of the bin, overlap wall sheets to the outside so that the bottom edge of the upper sheet is always on the outside of the sheet immediately below it. Caulk all vertical wall seams.
- On 6 to 8 tier models the upright stiffener is made in two pieces. The upper section of this stiffener should be installed as soon as the bin reaches three to five tiers in height. Use 3/8 x 1" bolts for all upright to side sheet connections. Include a flat washer against the nut at the point where the upright meets the top ring. (See [Figure 40 on page 43](#).)

Note

Special uprights are located at the left side of the door on 6 to 8 tier models. These uprights are color-coded as shown in the following table and have a "SPECIAL UPRIGHT" label. Special Uprights are installed on left side of door with opposite orientation to standard upright.

Table 6. Special Uprights

PART No.	236341	236541	236543
BIN USED ON	6 TO 8 TIER	7 TIER	8 TIER
COLOR CODE	YELLOW	ORANGE	WHITE

5.4. Bin Roundness

It is imperative that the bin be as round as possible. The following steps describe how to ensure the bin is round.

1. Verify that the foundation meets all the requirements of the installation.
2. Scribe the bin circumference onto the foundation as follows:
 - a. Anchor a string to the exact center of the concrete foundation.
 - b. Consult the following table to find the scribe radius for the size of the bin being assembled.
 - c. Using the required string length, scribe the bin circumference onto the foundation.

The radius values given in the chart are 3/4–inch smaller than the wall sheet radius at the bottom. This ensures that the scribed circle can be seen during assembly. A perfectly placed ring of sheets should be 3/4 inch on the outside of this scribed circle.
3. After the first ring of wall sheets has been assembled, check the position and roundness of the ring:
 - a. Verify that the maximum amount that the bin is out of round is no more than 0.75" on the radius, when measured from the center of the bin.
 - b. Verify that the wall sheets form a smooth circle with no flat spots or cauliflower shaped curves.
 - c. Before anchoring the bin to the foundation, re-check to ensure that the bin is round and within tolerance.

Correcting for roundness becomes much more difficult the longer you wait.
4. Locate anchor bolts towards the outside of the anchor bolt slots (away from bin) to permit the incremental expansion that can occur with the initial filling of the bin.
5. When setting jacks, make sure they are also set round and that they are anchored to the concrete.

Table 7. Scribe Radius – 14' and 19' Bins

Nominal Bin Diameter (ft)	Scribe Radius (ft in)
14	6'10"
19	9'6"

5.5. Wall Sheet and Upright Layout

5.5.1 Models 144 to 148 Flat Bottom Bins

Figure 9. Model 144 — Door in first and second tiers

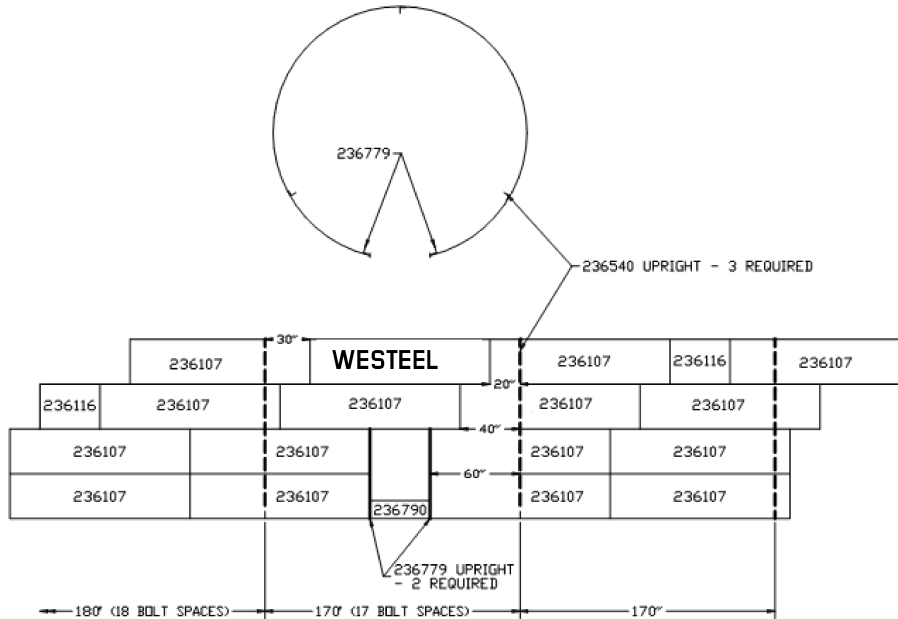
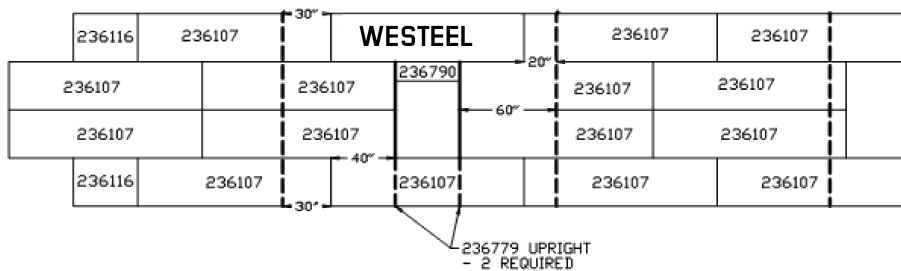

Figure 10. Model 144 — Door in second and third tiers



Note

1. Ensure that uprights are bolted at wall sheet-to-top angle connection.
2. **Ensure that uprights are in contact with base plates.**
3. Do not cut through uprights when using an aeration transition.

Figure 11. Model 145 — Door in first and second tiers

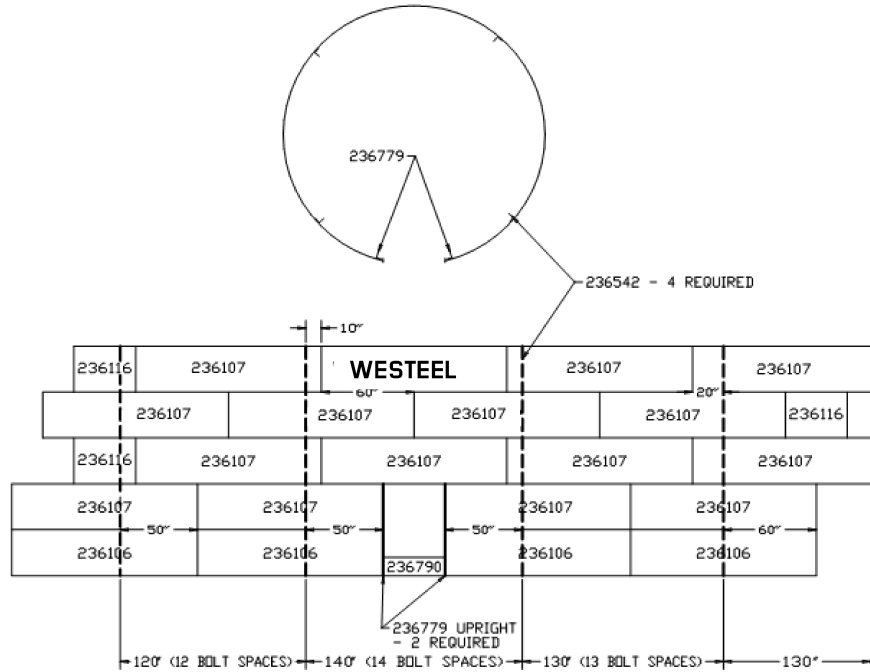
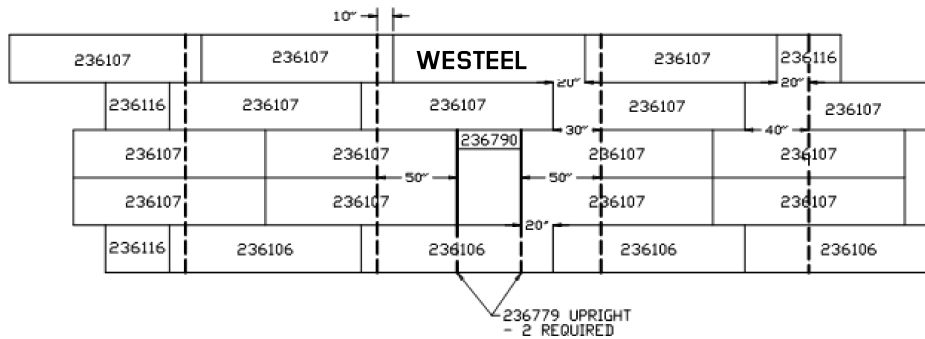

Figure 12. Model 145 — Door in second and third tiers



Note

1. Ensure that uprights are bolted at wall sheet-to-top angle connection.
2. **Ensure that uprights are in contact with base plates.**
3. Do not cut through uprights when using an aeration transition.

Figure 13. Model 146 — Door in first and second tiers

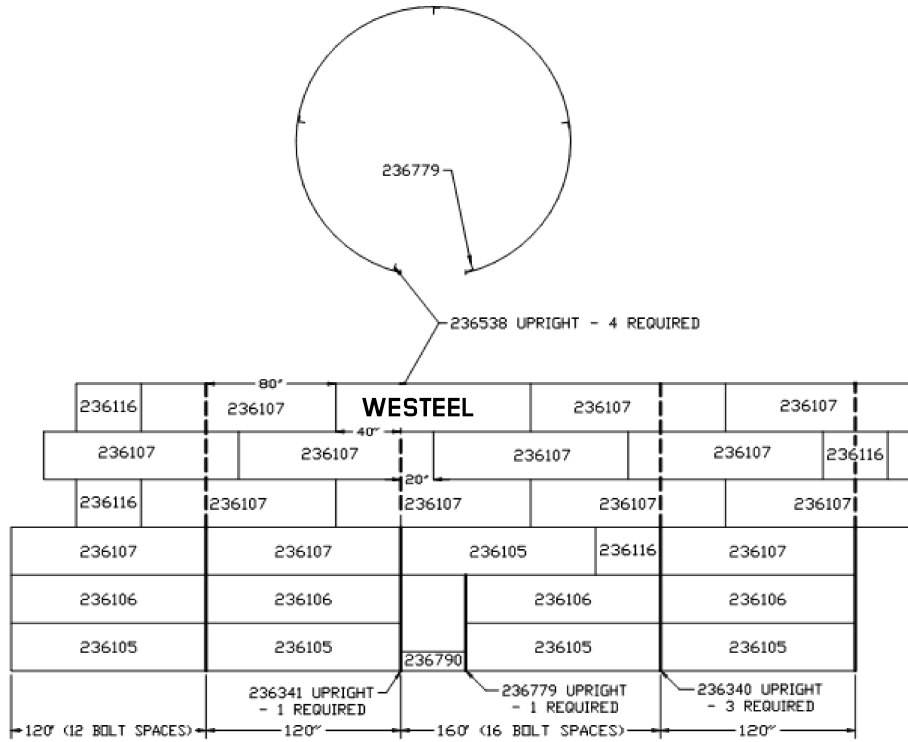
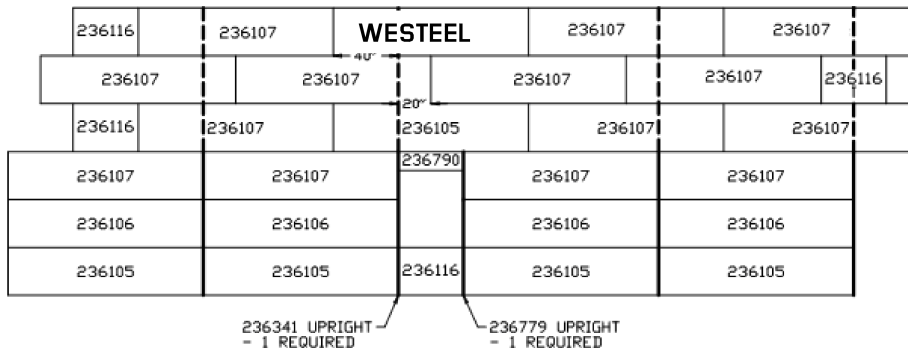

Figure 14. Model 146 — Door in second and third tiers



Note

1. Bolt uprights continuously at vertical wall seams in first three tiers.
2. Ensure that uprights are bolted at wall sheet-to-top angle connection.
3. ***Ensure that uprights are in contact with base plates.***
4. For details of the two upright overlap see [Figure 40 on page 43](#).

Figure 15. Model 147 — Door in first and second tiers

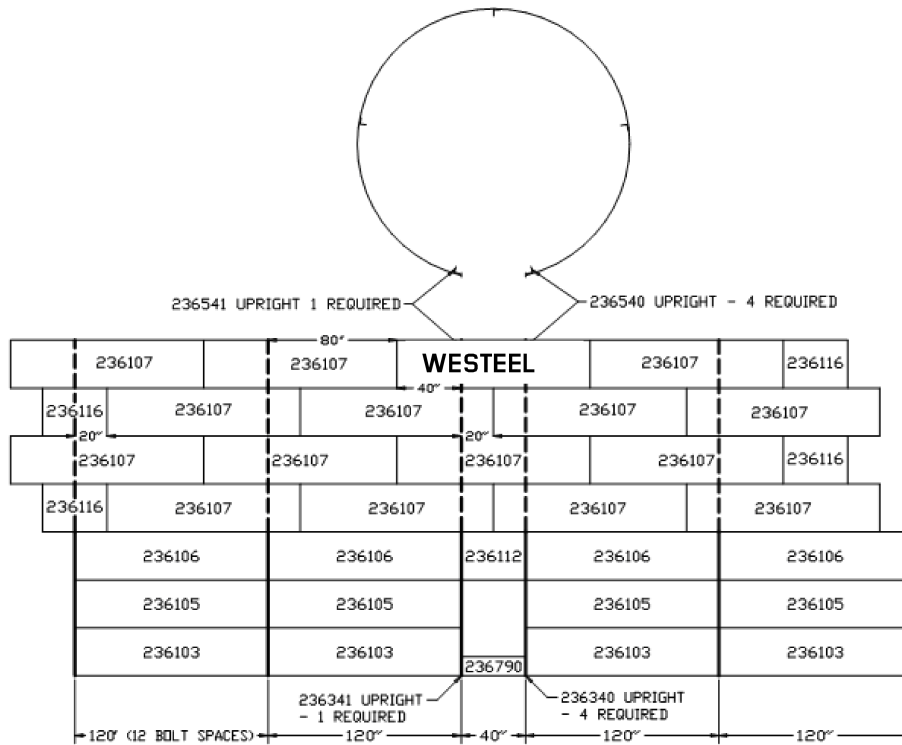
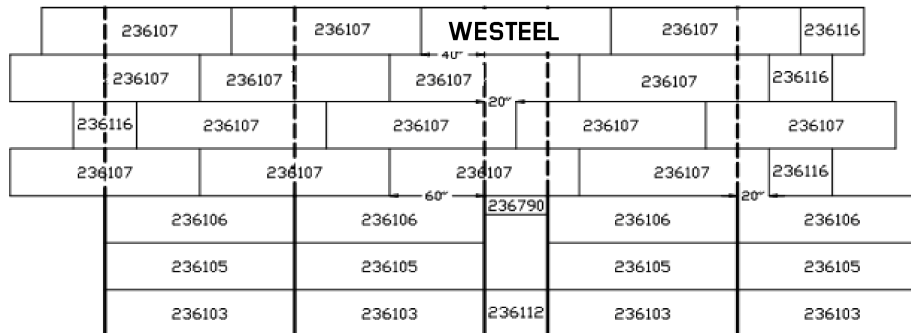

Figure 16. Model 147 — Door in second and third tiers



Note

1. Bolt uprights continuously at vertical wall seams in first three tiers.
2. Ensure that uprights are bolted at wall sheet-to-top angle connection.
3. ***Ensure that uprights are in contact with base plates.***
4. For details of the two upright overlap see [Figure 40 on page 43](#).

5.5.2 Models 144 to 148 Cone Mount Bins

Figure 19. Model 144 – Cone Mount Bin (without door)

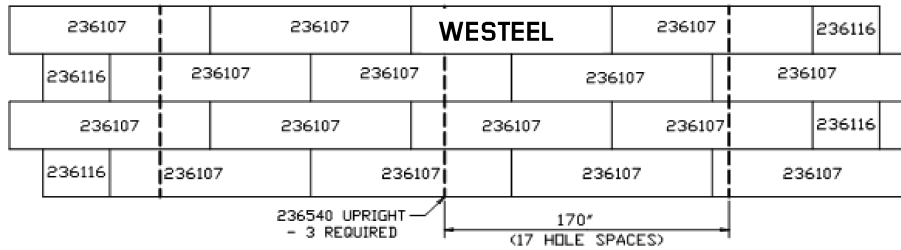

Figure 20. Model 145 – Cone Mount Bin (without door)

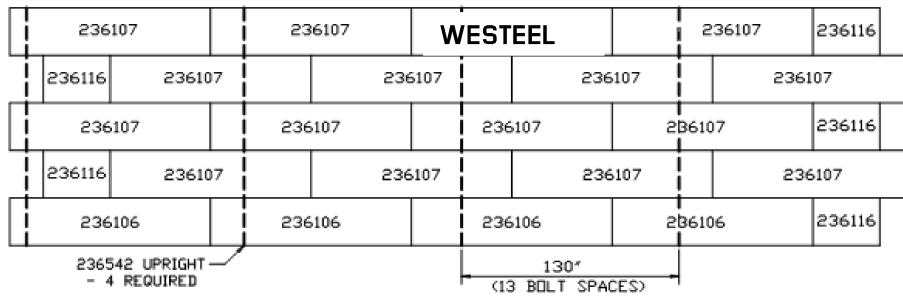
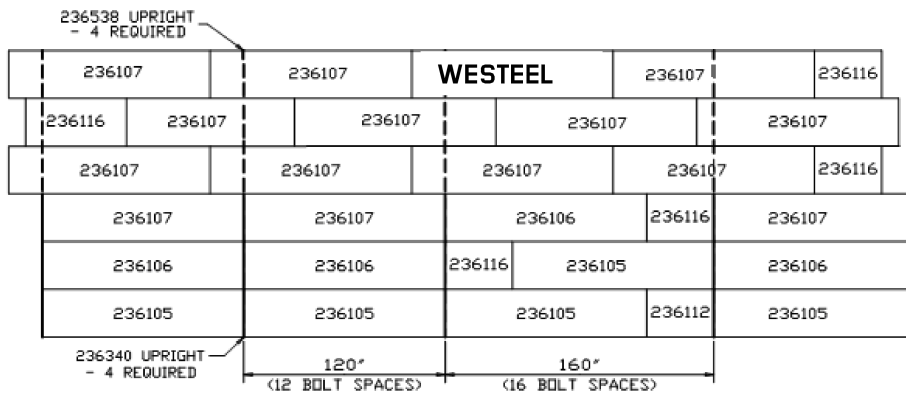

Figure 21. Model 146 – Cone Mount Bin (without door)



Note

1. For Model 146, bolt uprights continuously at vertical wall seams in bottom three tiers.
2. Ensure that uprights are bolted at wall sheet-to-top angle connection.
3. **Ensure that uprights are in contact with upright support brackets.**
4. For details of the two upright overlap see [Figure 40 on page 43](#).
5. **For Model 145 bin on hopper, the upright to wall sheet joint requires reinforcement (see [Section 5.7 – Two-Piece Upright Installation on page 43](#)).**
6. **Bins used for pea storage require upright upgrade kits P/N 235629 (145) or 235625 (146).**
7. **See Important Notes in [Section 5.11 – Bin to Hopper Cone Installation on page 52](#)**

Figure 22. Model 147 — Cone Mount Bin (without door)

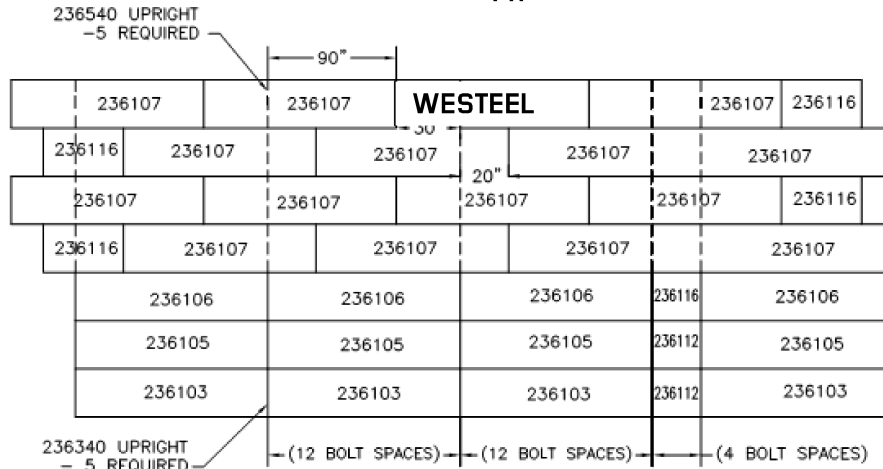
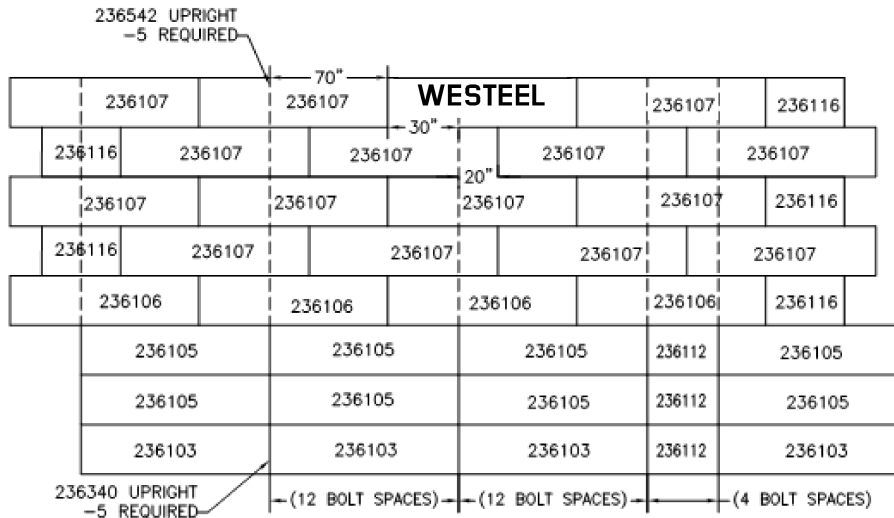

Figure 23. Model 148 — Cone Mount Bin (without door)



Note

1. For Models 147 and 148, bolt uprights continuously at vertical wall seams in bottom three tiers.
2. Ensure that uprights are bolted at wall sheet-to-top angle connection.
3. **Ensure that uprights are in contact with upright support brackets.**
4. For details of the two upright overlap see [Figure 40 on page 43](#).
5. **7 & 8 tier bins require special high-capacity hoppers**
6. **Bins used for pea storage require upright upgrade kits P/N 235633 (147) or 235635 (148).**
7. See Important Notes in [Section 5.11 – Bin to Hopper Cone Installation on page 52](#)

5.5.3 Models 194 to 198 Flat Bottom Bins

Figure 24. Model 194 – Door in first and second tiers

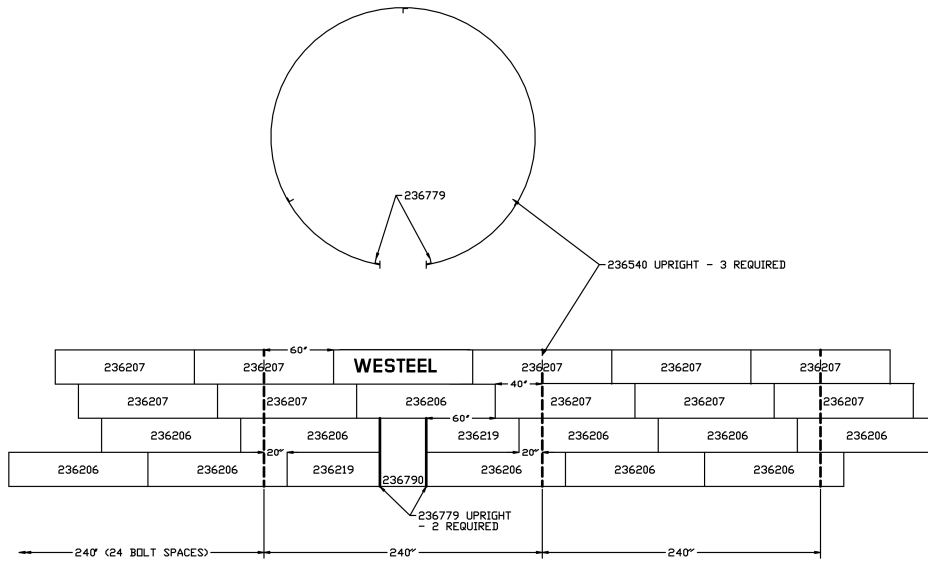
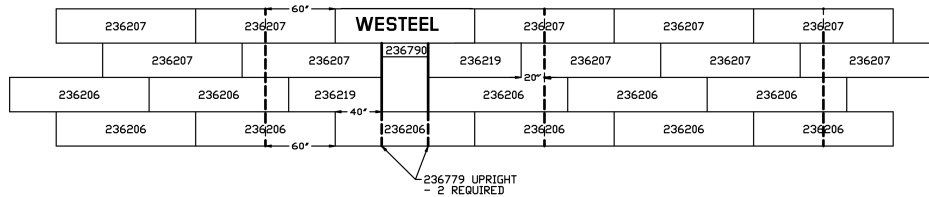

Figure 25. Model 194 – Door in second and third tiers



Note

1. Ensure that uprights are bolted at wall sheet-to-top angle connection.
2. ***Ensure that uprights are in contact with base plates.***
3. Do not cut through uprights when using an aeration transition.

Figure 26. Model 195 — Door in first and second tiers

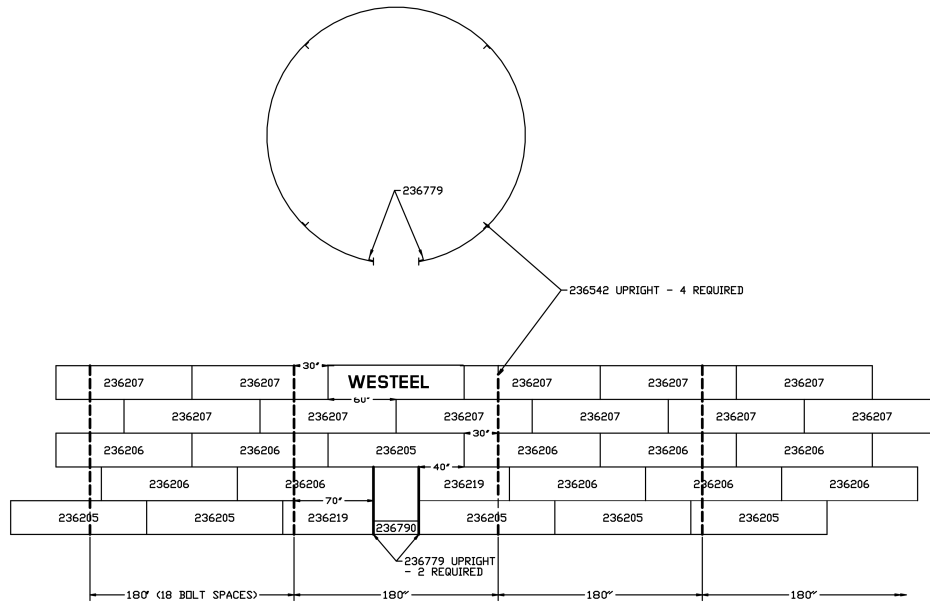
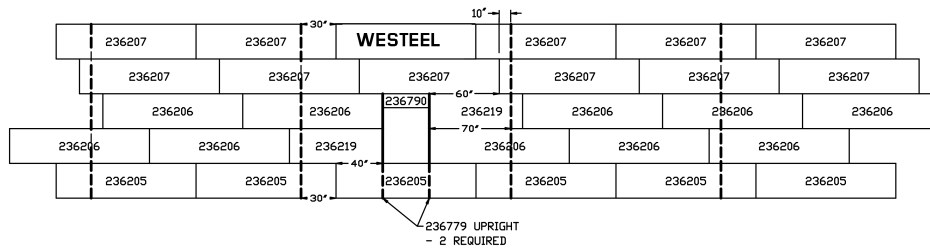

Figure 27. Model 195 — Door in second and third tiers



Note

1. Ensure that uprights are bolted at wall sheet-to-top angle connection.
2. ***Ensure that uprights are in contact with base plates.***
3. Do not cut through uprights when using an aeration transition.

Figure 28. Model 196 — Door in first and second tiers

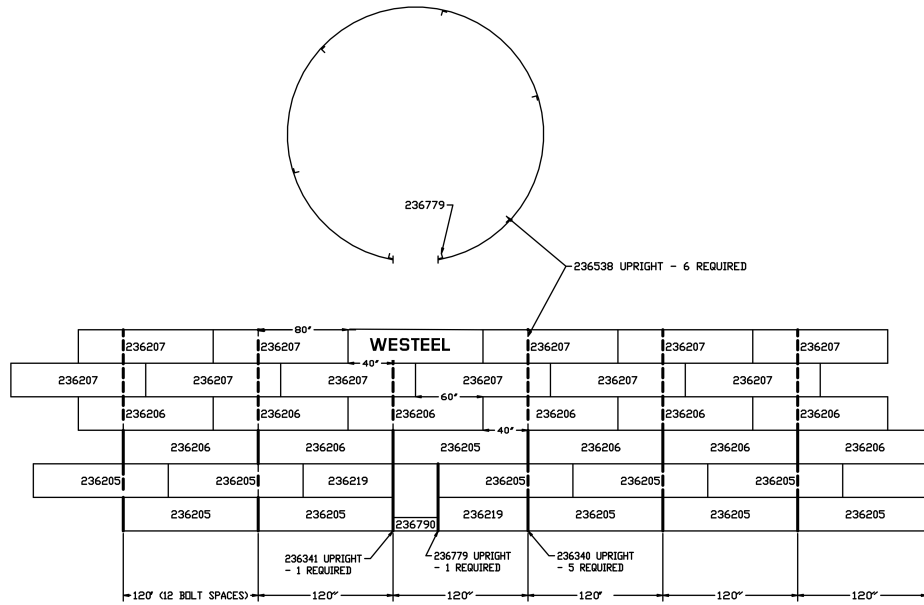
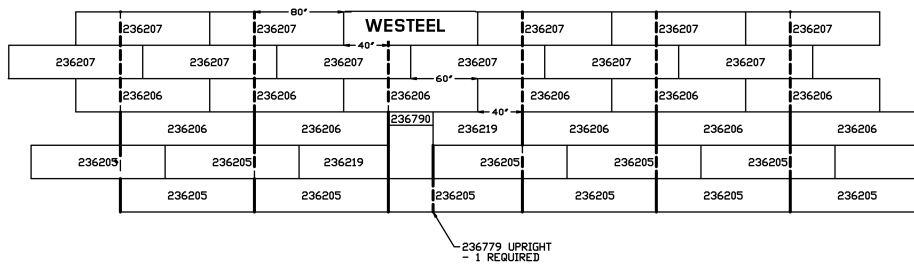

Figure 29. Model 196 — Door in second and third tiers



Note

1. Bolt uprights continuously at vertical wall seams in first three tiers.
2. Ensure that uprights are bolted at wall sheet-to-top angle connection.
3. ***Ensure that uprights are in contact with base plates.***
4. For details of the two—piece upright overlap see [Figure 40 on page 43](#).

Figure 30. Model 197 — Door in first and second tiers

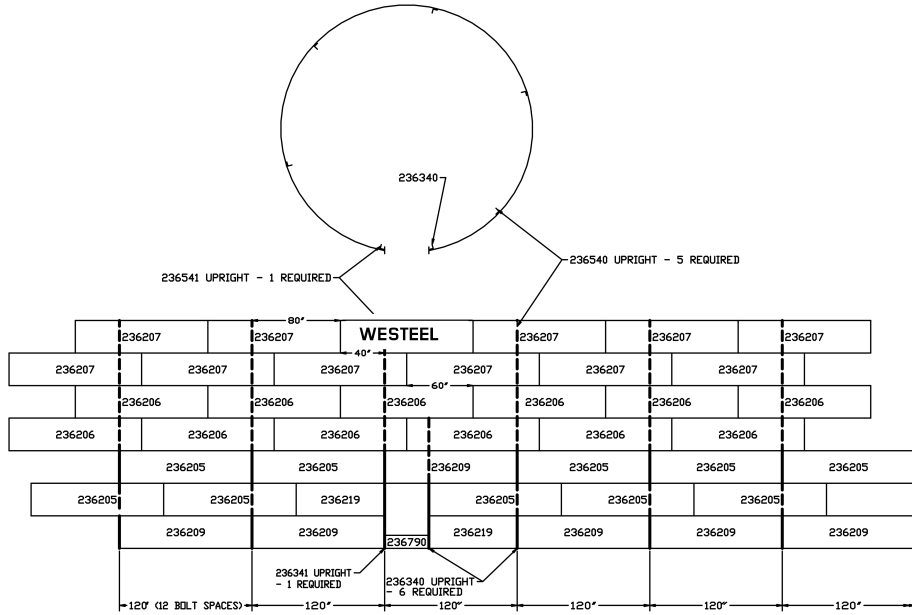
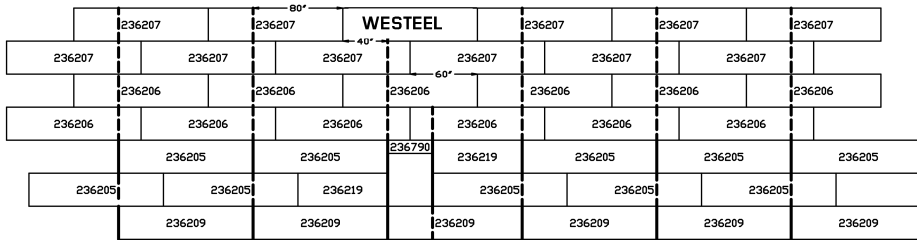

Figure 31. Model 197 — Door in second and third tiers



Note

1. Bolt uprights continuously at vertical wall seams in first three tiers.
2. Ensure that uprights are bolted at wall sheet-to-top angle connection.
3. ***Ensure that uprights are in contact with base plates.***
For wood floors, uprights must be located directly over a skid member.
4. For details of the two—piece upright overlap see [Figure 40 on page 43](#).

Figure 32. Model 198 — Door in first and second tiers

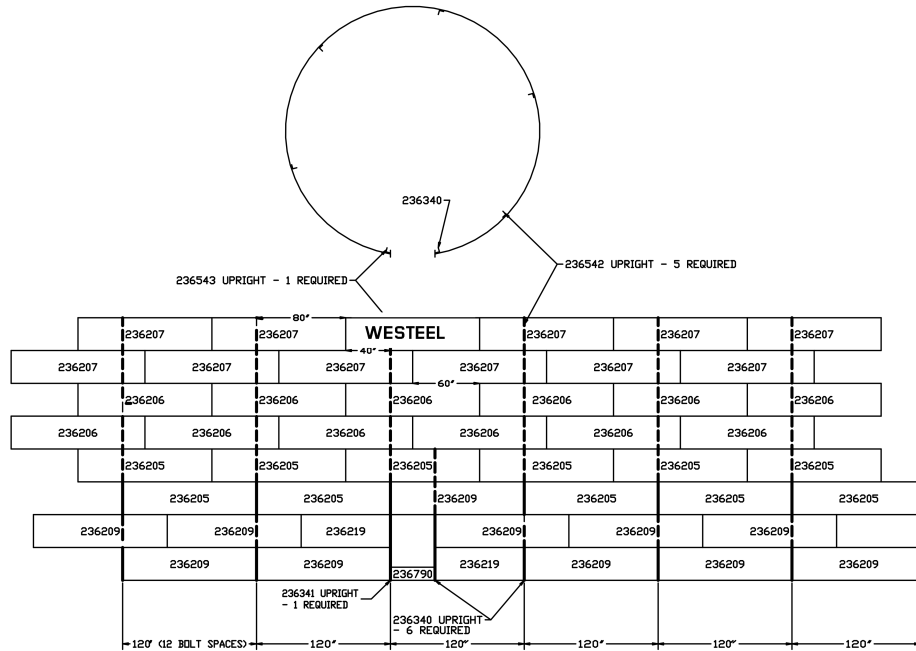
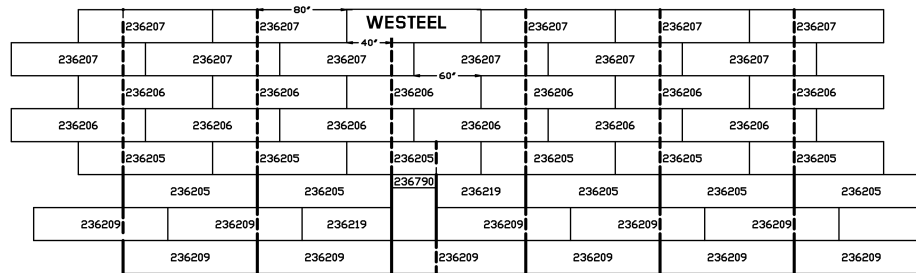

Figure 33. Model 198 — Door in second and third tiers



Note

1. Bolt uprights continuously at vertical wall seams in first three tiers.
2. Ensure that uprights are bolted at wall sheet-to-top angle connection.
3. ***Ensure that uprights are in contact with base plates.***
For wood floors, uprights must be located directly over a skid member.
4. For details of the two—piece upright overlap see [Figure 40 on page 43](#).

5.5.4 Models 194 to 198 Cone Mount Bins

Figure 34. Model 194 – Cone Mount Bin (without door)

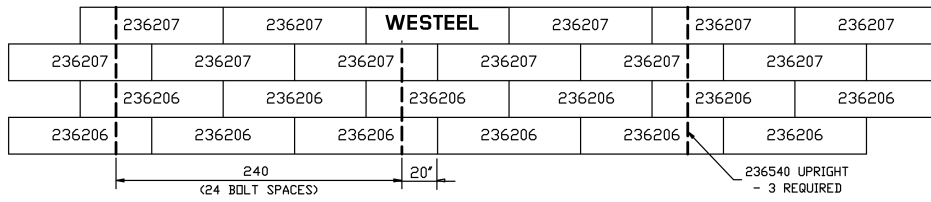

Figure 35. Model 195 – Cone Mount Bin (without door)

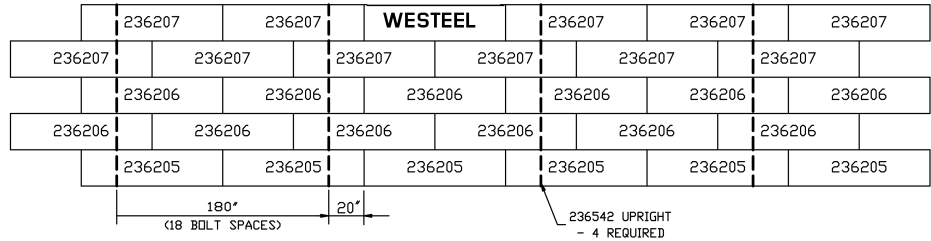
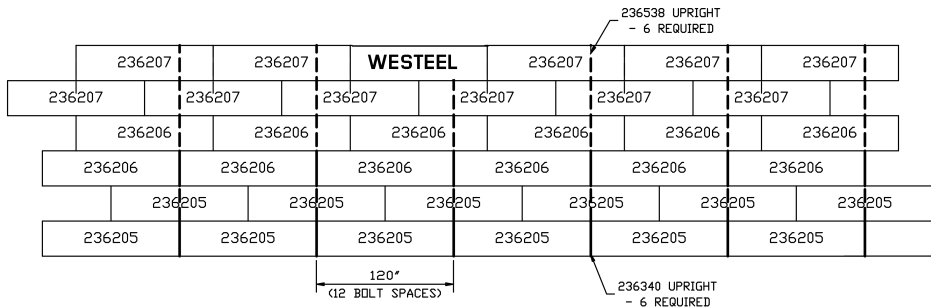

Figure 36. Model 196 – Cone Mount Bin (without door)



Note

1. For Model 196, bolt uprights continuously at vertical wall seams in the first and third tiers from the bottom.
2. Ensure that uprights are bolted at wall sheet-to-top angle connection.
3. ***Ensure that uprights are in contact with upright support brackets.***
4. For details of the two upright overlap see [Figure 40 on page 43](#).
5. Bins used for pea storage require upright upgrade kits P/N 235630 (195) or 235626 (196).
6. See Important Notes in [Section 5.11 – Bin to Hopper Cone Installation on page 52](#)

Figure 37. Model 197 – Cone Mount Bin (without door)

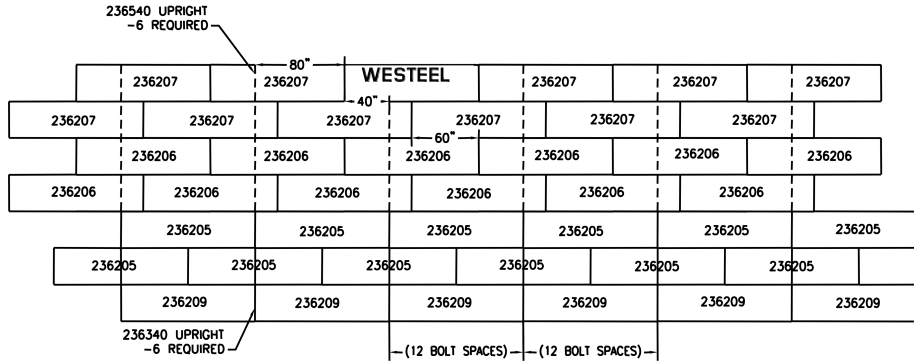
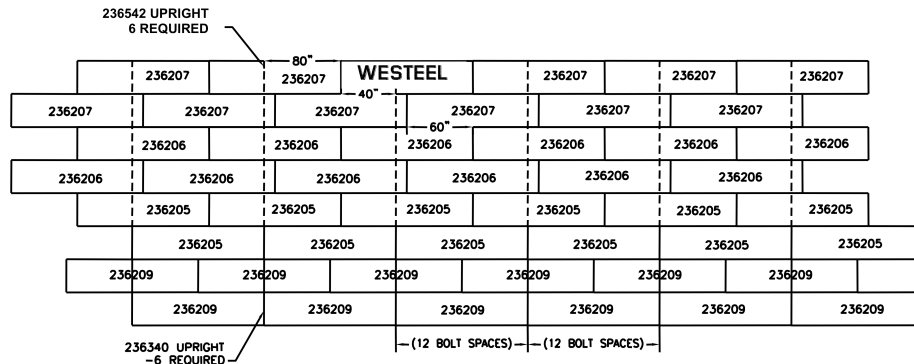

Figure 38. Model 198 – Cone Mount Bin (without door)



Note

1. For Model 197 and 198, bolt uprights continuously at vertical wall seams in the first and third tiers from the bottom.
2. Ensure that uprights are bolted at wall sheet-to-top angle connection.
3. **Ensure that uprights are in contact with upright support brackets.**
4. For details of the two upright overlap see [Figure 40 on page 43](#).
5. **7 & 8 tier bins require special high-capacity hoppers**
6. **Bins used for pea storage require upright upgrade kits P/N 235634 (197) or 235636 (198).**
7. See Important Notes in [Section 5.11 – Bin to Hopper Cone Installation on page 52](#)

5.6. Bottom Ring Angle and Upright Installation

Bottom Ring Angle Installation

1. Attach one bottom ring angle under the grain bin door.
2. Centre the angle under the door and attach it to the side sheets with 3/8 x 1" bolts.
3. Overlap the second bottom ring angle one hole and bolt to the side sheet with 3/8 x 1" bolt using a flat washer on the inside of the lap.
4. Caulk across the angle at the overlap.

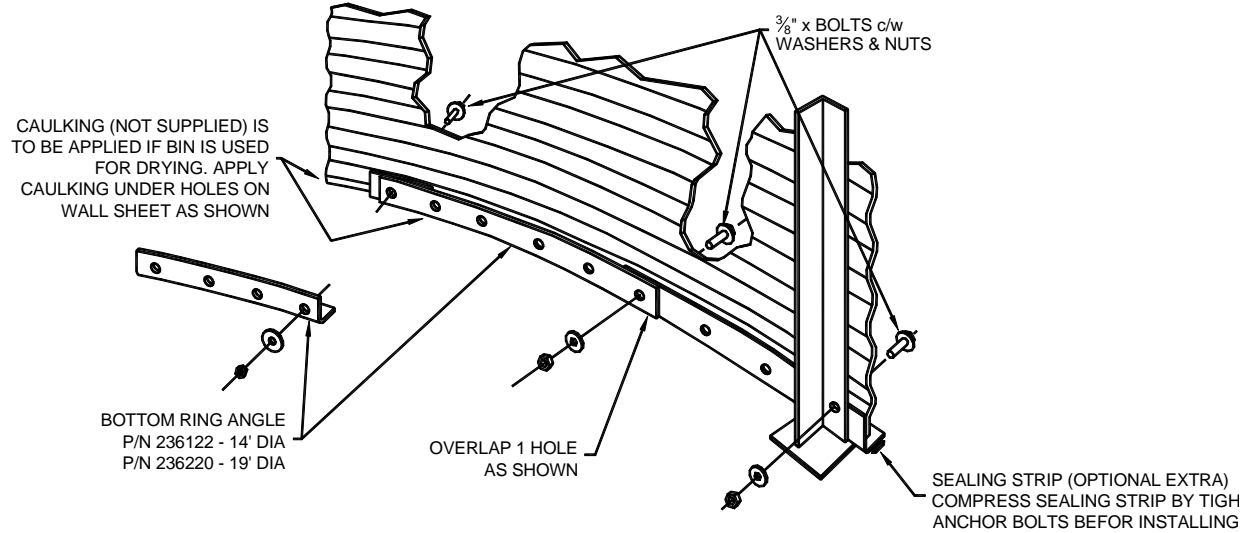
Figure 39. Bottom Ring Assembly**Upright Installation****1. For 4 & 5 Tier Models:**

- a. Install the uprights as shown in [Section 5.5 – Wall Sheet and Upright Layout on page 28](#) and [Figure 40 on page 43](#).
- b. Use 3/8 x 1" bolts with flat washers on the inside (against the nut) at both top and bottom ring angles.

Note

Uprights have top and bottom ends. For proper orientation, see [Figure 40 on page 43](#).

2. For 6 To 8 Tier Models:

Upright stiffeners are made in two pieces.

- a. Install the upper section as soon as the bin reaches three to five tiers in height as per detail for 4 & 5 tier models above.
- b. Install the bottom portion of the upright as shown in [Section 5.5 – Wall Sheet and Upright Layout on page 28](#) and [Figure 41 on page 44](#).
- c. Use 3/8 x 1" bolts with flat washers on the inside (against the nut) at the bottom ring angle and at the middle of the two-piece upright.

Figure 40. Upright Assembly

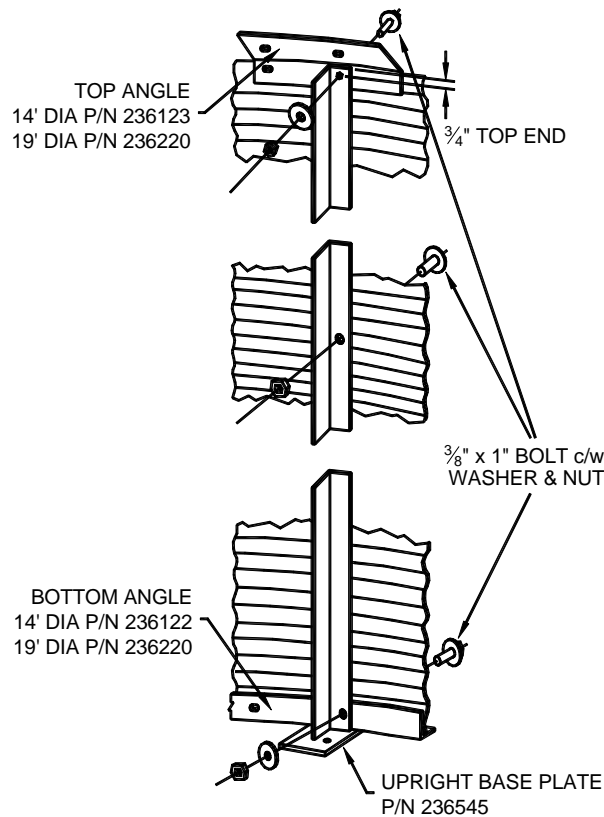

CAUTION When cutting a fan transition hole, do not cut into the bottom angle or into uprights.

3. Shim the upright base plate to ensure solid contact with the foundation.
4. Secure the plate with adhesive or a concrete nail.

5.7. Two-Piece Upright Installation

FOR 6, 7 & 8 TIER MODELS (8 TIER MODEL SHOWN)

1. Install the uprights as shown on the side sheet layouts.
2. On 6, 7 & 8 tiers bins, the upright stiffener is made in two pieces and the upper section should be installed as soon as the bin is three to five tiers in height.
3. Use 3/8" x 1" bolts and flat washers on the inside (against the nut) at both top and bottom ring angles and at the middle of two piece uprights.

Figure 41. Two-Piece Upright

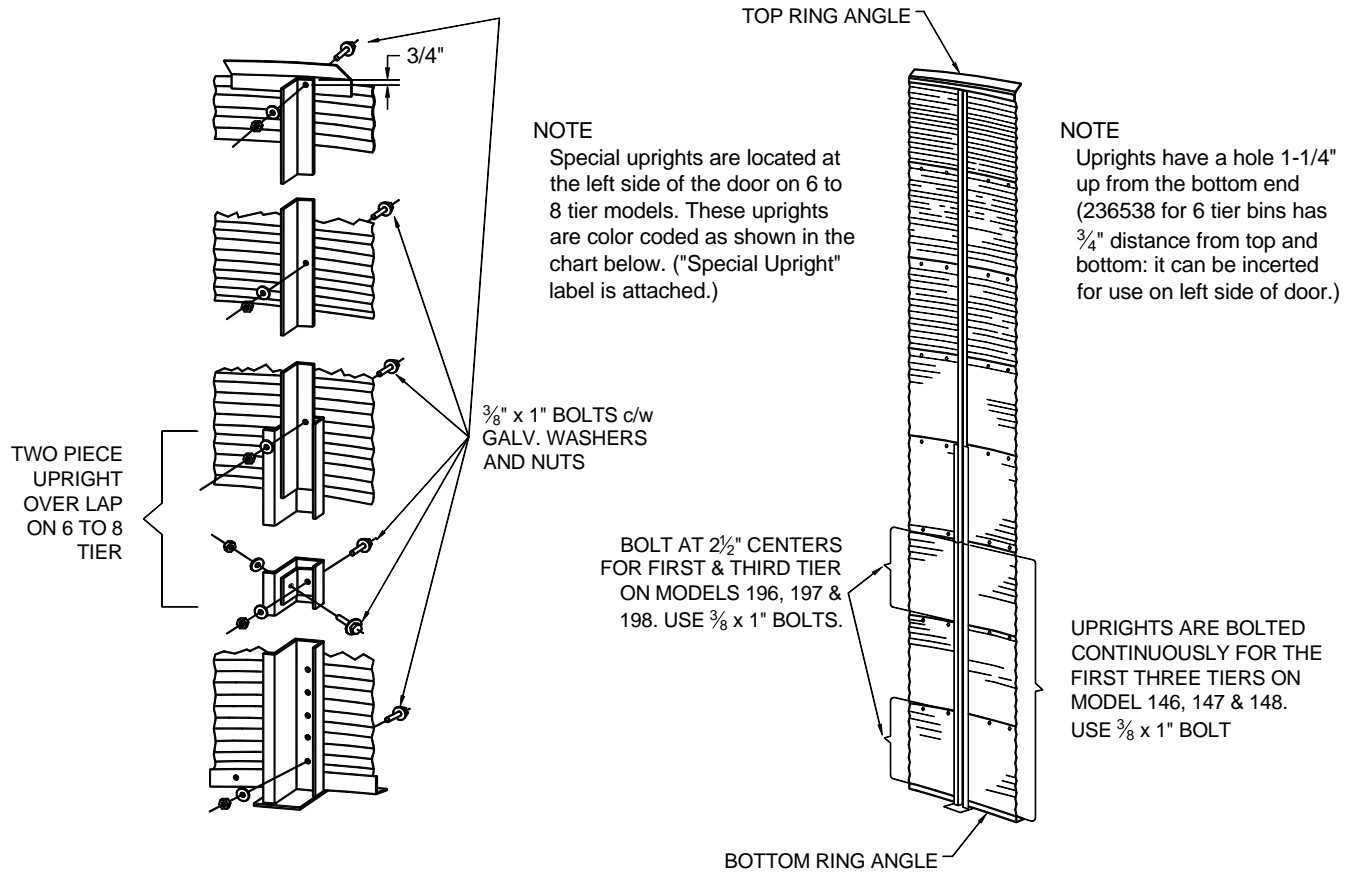

Note

Shim upright base plate to ensure solid contact with foundation. Secure plate with adhesive or concrete nail.

Note

DO NOT CUT UPRIGHTS TO INSTALL FAN TRANSITION

Table 8. Parts List

DESCRIPTION	SERIES 14 PART NUMBER	SERIES 19 PART NUMBER
TOP ANGLE	236123	236223
BOTTOM ANGLE	236122	236220
BASE PLATE	236545	
BOTTOM UPRIGHT	236340	
BOTTOM UPRIGHT @ LEFT HAND SIDE OF DOOR	236341 (SPECIAL UPRIGHT - YELLOW)	
TOP UPRIGHT - 6 TIER	236538	
TOP UPRIGHT - 7 TIER	236540	
TOP UPRIGHT - 7 TIER @ LEFT HAND SIDE OF DOOR	236541 (SPECIAL UPRIGHT - ORANGE)	
TOP UPRIGHT - 8 TIER	236542	
TOP UPRIGHT - 8 TIER @ LEFT HAND SIDE OF DOOR	236543 (SPECIAL UPRIGHT - WHITE)	

5.8. Upright Reinforcement Model 145 Cone Mount Bin

Mounting Screw Installation

Model 145 bins are mounted on hoppers using #12 x 7/8" self-drilling screws (45 included).

Install the screws during normal assembly, regardless of whether the addition of hoppers is planned.

1. Install the screws from outside the bin, through the wall sheet and into the upright.
2. Use two screws per wall sheet, screwing them into the "valley" between corrugations, spaced at approximately 10" on centre. (See [Figure 42 on page 45.](#))
3. Install screws to the full height of the bin.
4. To be effective, make sure the screws go solidly into the upright. (Screws do not have to be exactly on centre of the upright.)
5. Avoid over-tightening. Tighten just enough to ensure good contact of the sealing washer.
6. Install 10 screws into each of the four long uprights (#236542). Five extra screws are provided.
7. For best results, use a TEKS screw driver, operating at 2500 rpm with a self-releasing clutch.

Figure 42. Upright Reinforcement

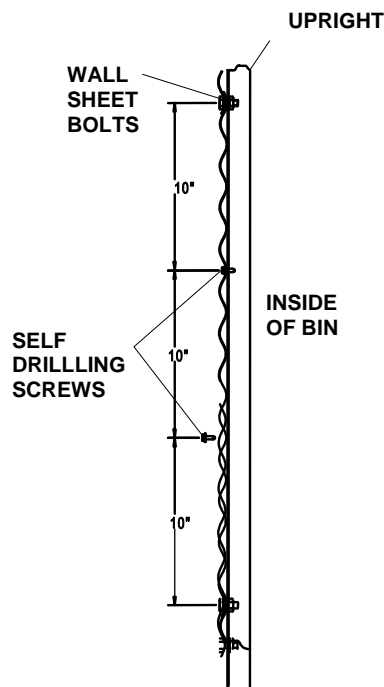

Bolt and Fastener Check

1. When the bin is complete and the bottom ring angle is in position on the anchor bolts, tighten all bolts. (See [Section 7.5 – Recommended Bolt Assembly on page 64.](#))
2. When tightening the bottom wall sheet to the bottom ring angle, Sealform or hopper cone, use the following tightening sequence to prevent the side sheet from bulging when tightening the last few bolts. (See [Figure 43 on page 46.](#))

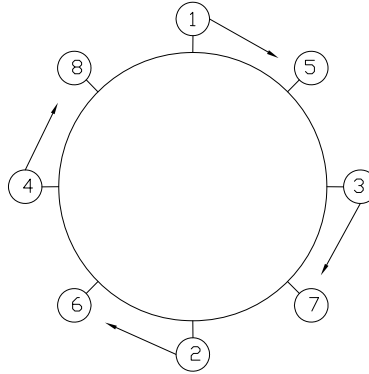
Figure 43. Tightening Sequence**Note**

Tightening the bolts progressively around the bottom ring angle without following the suggested sequence may cause hole misalignment and sheet bulging due to hole size tolerances.

- a. Start tightening bolts along the vertical seam at position 1.
- b. Tighten bolts in a clockwise direction along the horizontal seam and ring angle until next vertical seam is reached.
- c. Move to position 2.
- d. Repeat the procedure as done at position 1.
- e. Tighten the vertical seam and then the horizontal seam.
- f. Move to position 3.
- g. Continue the sequence as shown in [Figure 43 on page 46](#).

Note

Your installation may have a different number of vertical seams depending on your bin diameter, but the tightening sequence remains the same

Note

A minimum of six equally-spaced anchor bolts are required per bin, although one anchor bolt per each slot in the bottom ring angle is recommended. A foundation sealing strip (optional extra available from Westeel dealers) should be installed to seal the bin to the concrete and to accommodate slight bin movement which may occur during loading (see [Figure 40 on page 43](#)). Insert base plates under the uprights, filling any gaps. This provides for full transfer of the vertical load carried by the uprights directly to the foundation.

Bin Lifting Equipment Removal

1. Remove the bin crane, pole, (or lifting jack lugs).
2. Inspect the assembled bin's connections.

5.9. Door Installation

Door Uprights

1. Install uprights on both sides of door as per wall sheet layouts.
2. Bolt uprights to bottom ring angle, wall sheet and door jamb using 3/8" x 1" bolts and nuts.
3. Use 3/8" flat washers wherever slots occur in uprights.
4. Tighten all bolts, including those above and below door.

Figure 44. Door Uprights

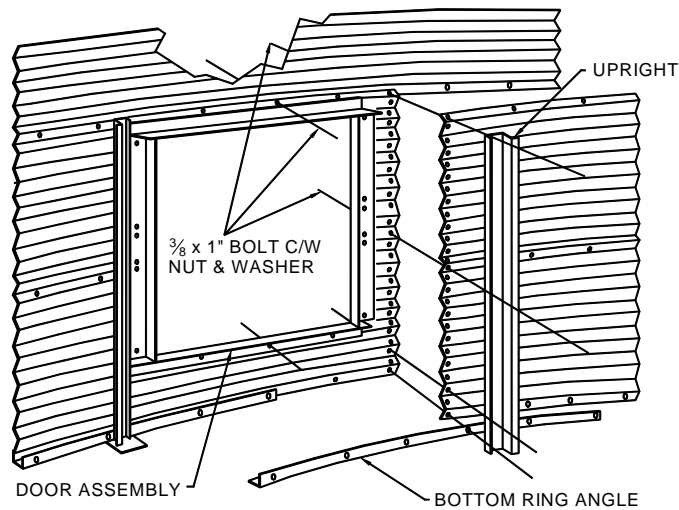

Door

1. Apply caulking strip to outside of line of holes as illustrated.
2. Install door assembly behind upper sheet in order to shed water.
3. Bolt along horizontal seams at top and bottom using 3/8" x 1" bolts and nuts.
(Leave corners open for uprights.)
4. Use 3/8" flat washers over three slots in header.
5. Do not tighten hardware at this time.
6. Locate door tie-back to secure the door in open position.

Note

Any of the chain links can be used to bolt through to the bin at an existing or field drilled wall sheet or stiffener hole. Chain links can be cut if shorter door tie-back is needed. The door tie-back uses a hook to attach to the door handle's lockable ring.

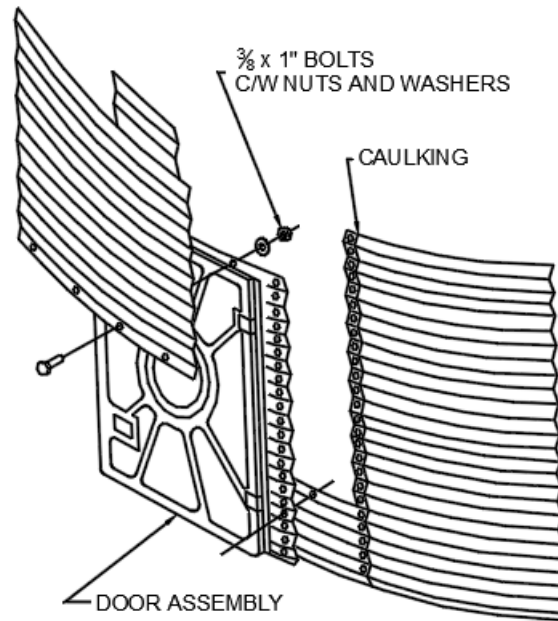
Figure 45. Door Installation**Latch Operation**

1. Ensure that tie bar latches operate properly.
2. Lubricate both sides of latch end as shown.

Latching mechanism will become looser after first grain load. Some pre-stressing of latch is required to ensure a tight seal. The latch should require firm pressure to close.

3. If tie bar latches will not engage latch keepers or if tie bar is not flat against door jambs with latches closed, proceed to adjust one side at a time as follows:
 - a. On the "open" side of the door, loosen the two bolts holding the latch keeper to the jamb.
 - b. Use a C-clamp to hold the tie bar tightly closed against the jamb.
 - c. Turn the handle to the closed position with full engagement of the keeper.
 - d. Wedge a flat screwdriver between the tie bar and the latch keeper above and below the tie bar (only shown from above).
 - e. Tighten the bolts holding the keeper.
 - f. Repeat on the hinge side of the door.

Figure 46. Latch Engagement

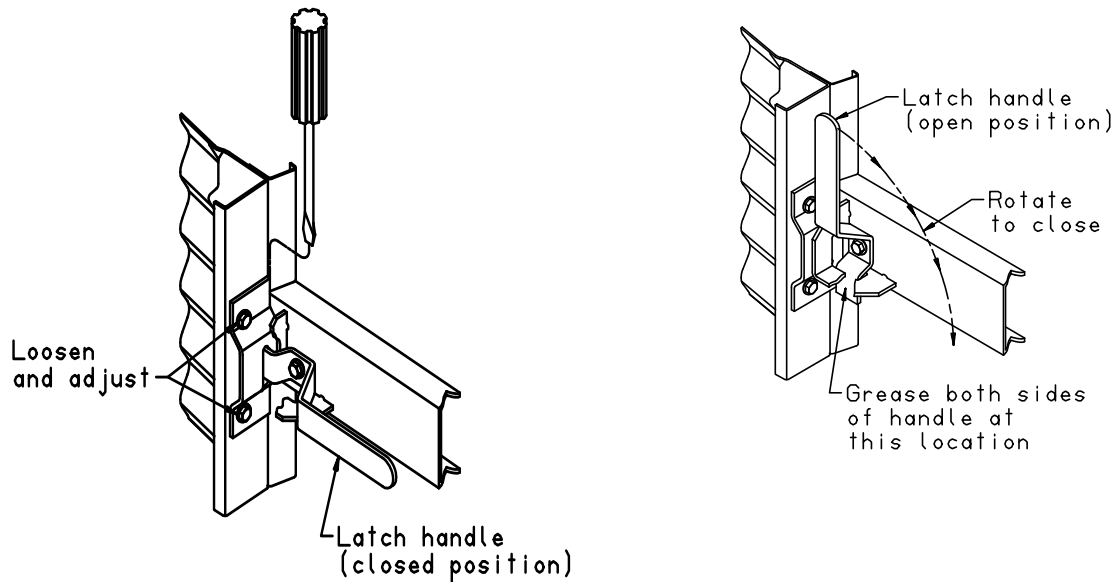

5.10. Auger Chute Assembly

Note

Right and left are viewed from the outside of the bin looking in (as per auger chute sides).

Auger Chute Installation

1. Open the auger chute package (235125) and remove the auger chute cover, auger chute sides and door hardware package.
2. Attach the chute sides to the chute cover, as shown in [Figure 47 on page 50](#).
 - a. Hold the 5/16" square nuts up to the bottom of the hole in the chute side and start the bolt from the top of the chute cover.
 - b. Once the bolt has started into the nut, the nut will not turn, and the bolts can be tightened from the top.
 - c. Do not tighten until the entire assembly has been attached to the tie bar.

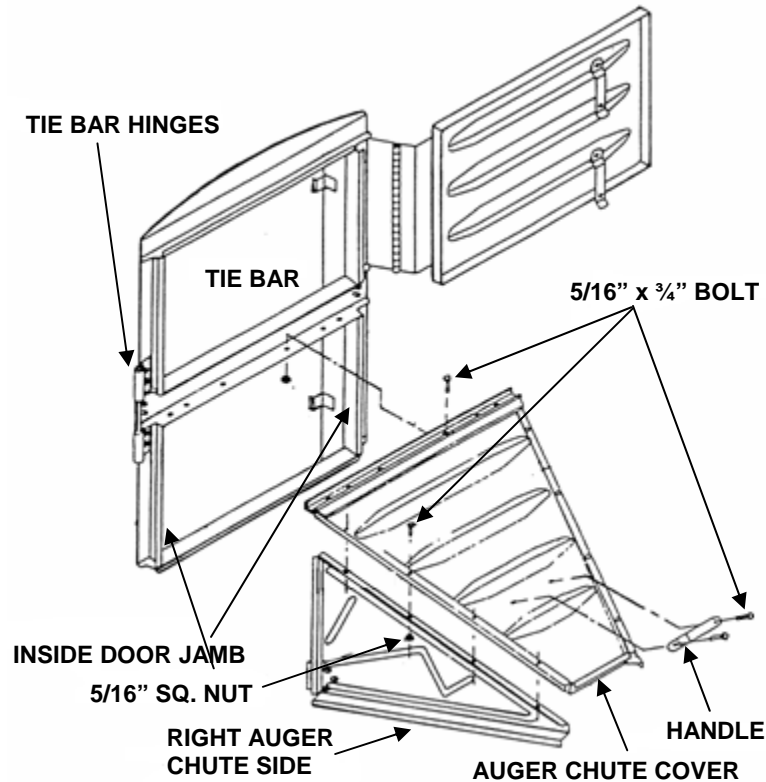
Figure 47. Auger Chute Assembly

3. Attach handle to chute cover.
4. Attach completed auger chute to tie bar as shown in [Figure 47 on page 50](#).
Do not tighten the hardware.
5. Lift the auger chute and lower it.
 - a. Ensure that chute sides sit firmly on inside door jambs.
 - b. Clips on chute sides must be on inside of inside door jambs.
 - c. Be sure the tie bar is firmly latched and auger chute is seated over the inside door jambs.
 - d. Tighten all chute hardware.
6. Slide rubber latch protectors onto tie bar latch handles. Apply a few drops of soap inside protector to ease assembly.
7. Attach tie back chain to the bin wall at the second bolt to the right of the door as shown in [Figure 48 on page 51](#).
8. Open the tie bar fully.
9. Lift auger chute up and hang it from chain as shown in [Figure 48 on page 51](#).
This will allow for easy bin clean-out during emptying.

Figure 48. Tie Back Chain

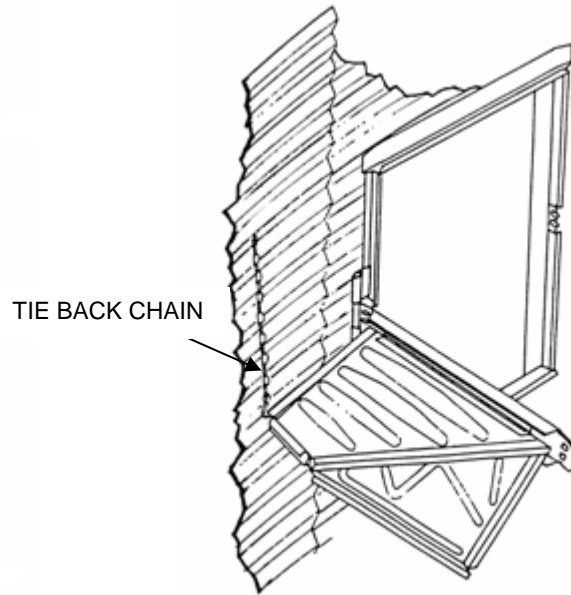

10. If tie bar begins to sag or does not close easily over load pins, loosen tie bar hinge bolts and adjust (see [Figure 46 on page 49](#)).

Extra Door Board Installation

For drying bins with under floor unloading:

1. Replace the auger chute with the optional door board package (235126).
2. Remove 3/8" x 3/4" bolts from lower left inside door jamb (see [Figure 47 on page 50](#)).
3. Attach the lower door board as per the upper door board.
4. Use 5/16" x 3/4" bolts and nuts to plug holes in tie bar.

CAUTION Before loading the bin with grain, be sure the tie bar is firmly latched and auger chute is seated over the inside door jambs.

5.11. Bin to Hopper Cone Installation

Use only Westeel hopper cones which are specifically designed to suit Westeel Series 14 & 19 Bins. When installing a hopper cone to a new bin installation or a retro-fit to an existing bin site, refer to the instructions in this section.

Figure 49. Bin and Hopper Alignment

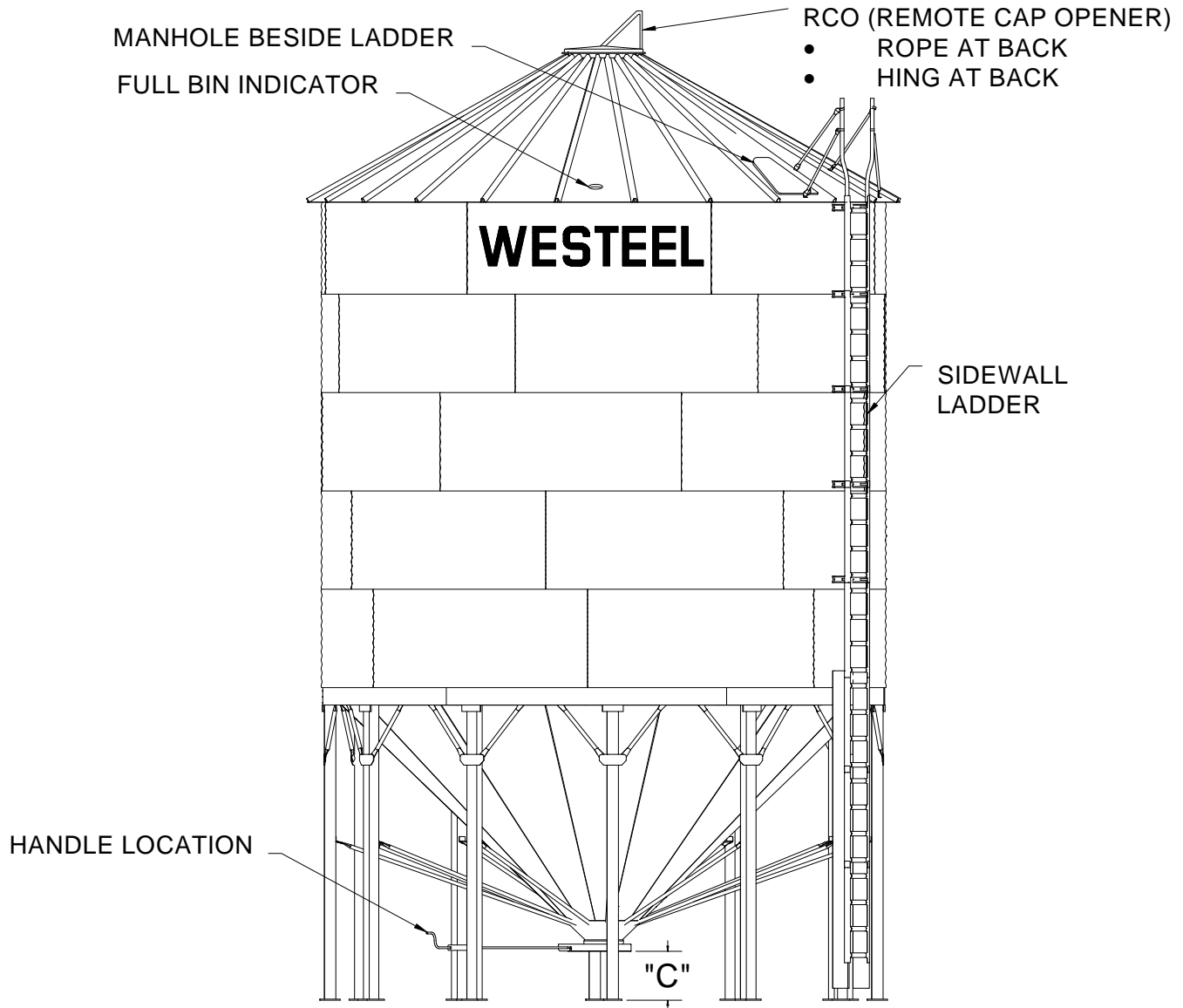

New Bin Application

1. Pour the foundation as per the instructions provided with your hopper.
 - a. Ensure the foundation has fully cured before continuing the assembly of your bin.
 - b. If a Westeel skid base is used, a compacted gravel base can be used instead of a concrete foundation.
 - c. Follow the soil bearing information and site preparation instructions on [Section 4.4 – Site Selection on page 18](#) and [Section 6.1 – Capacity and Dimensions on page 55](#).

2. Assemble the bin as per the instructions in [Section 5. – Assembly on page 19](#). Disregard the Bottom Ring Angle and Door Installation instructions when your bin is installed on a hopper cone.
3. Position the hopper cone on the foundation and align the hopper with the bin as shown in [Figure 49 on page 52](#). **Ensure all bottom holes on the bottom wall sheets are clear of bolts.**
4. Use of a bin crane to lift your bin is recommended. Ensure the rated capacity of crane and all other lifting devices exceed the maximum bin weight. Lift the bin by placing a round support or tripod inside the bin directly under vent collar.
5. Loosen the vertical seams bolts on the bottom tier only for easy assembly.
 - a. Align bin with cone as shown in [Figure 49 on page 52](#).
 - b. Fasten the bin to the hopper cone with 3/8" x 1" bolts (c/w nut and flat washer).
 - c. Insert one bolt on one side and the next bolt on the opposite side of the bin.
 - d. Install the next two bolts at right angles to the first two. This will maintain correct spacing.
 - e. Install all other bolts.
 - f. Tighten the bolts (including the bottom tier seam bolts).
6. Place upright support brackets under each upright and fasten the bracket to the cone with self-tapping screws.
 - a. Ensure the load is transferred through the supports and support brackets.
 - b. If necessary, use steel shims (not supplied) to ensure full contact between the bracket and the upright.
 - c. Tighten all bolts.
 - d. Using the caulking supplied to seal around the inside of the wall sheet to hopper angle joint.
 - e. **Supports must be tightly shimmed to the upright support brackets. Failure to do so can result in wall sheet failure and will void the warranty**

Retro-fit Application

1. Before beginning the installation of the hopper cone to your existing bin, ensure that all retro-fit parts required are on site (i.e. replacement wall sheets, ladder sections, caulking, etc.) Refer to the foundation instructions provided with your hopper. **If you plan to re-use the existing foundation, a Westeel skid base must be used.**
2. **Do NOT place hopper legs directly on an old foundation or failure will occur.**
3. Position the hopper cone near the bin and foundation.
4. Remove fasteners at the bottom ring angle to wall sheet connection.
5. Remove the existing bin door and replace the wall sheets.
 - a. All fasteners on the first tier should be loosened to ease the bin to fit the hopper.
 - b. Ensure all old caulking is removed and the surface is cleaned to reapply caulking.
 - c. Any damaged sheets should be replaced prior to installing the bin on the hopper.
6. Lift the bin enough to allow removal of the bottom ring angle (see crane capacity notes above).
 - a. Remove all anchors flush with the concrete surface and clean the concrete surface.
 - b. Continue to lift the bin to clear the hopper cone and slide the cone to the center of the concrete pad.
 - c. Align the bin to the hopper as shown in [Figure 49 on page 52](#).
 - d. Lower the bin onto the hopper cone and fasten the bin to the mounting angle per instructions above.

- e. Tighten all bolts and anchor the hopper cone to the existing concrete foundation.
 - f. If a skid base is used on the concrete foundation, ensure that the skid is level.
 - g. Shim under the hopper cone legs to ensure load transfer to the foundation.
7. Install the upright support brackets as per instructions above.

Important

- Use only lifting devices of adequate rated capacity.
- Ensure the hopper cone is level and all load points contact the foundation.
- Ensure all fasteners are tightened as per torque instructions in [Section 7.5 – Recommended Bolt Assembly on page 64](#).

Table 9. Hopper Cone Specifications

HOPPER MODEL	NOMINAL DIAMETER	HOPPER CAPACITY*	HOPPER HEIGHT	DISCHARGE CLEARANCE "C"	BIN WEIGHT **
146 - 2100	14 ft.	228 Bushels	6'-7"	24"	1600 lbs.
147 - 2400					1900 lbs.
148 - 2700					2200 lbs.
196 - 4100	19 ft.	569 Bushels	8'-6"		2700 lbs.
197 - 4700					3100 lbs.
198 - 5300					3500 lbs.

* Hopper capacity only. For bin capacities, see [Section 6.1 – Capacity and Dimensions on page 55](#).

** Bin weight does not include weight of hopper, ladders or other accessories

6. Specifications

6.1. Capacity and Dimensions

Table 10. Bin Capacity Specifications

MODEL NO.	NO. OF TIERS	CAPACITY RATING					SHIPPING WEIGHT	
		VOLUME ⁽¹⁾		TONNES @ DENSITY BELOW				
		bu ⁽²⁾	m ³ ⁽³⁾	DENSITY (kg/m ³) ⁽⁴⁾			lbs	kg ⁽⁴⁾
144	4	1442	48.6	575	700	770	1240	560
145	5	1757	59.2	36	43	48	1450	660
146	6	2072	69.8	42	51	56	1780	810
147	7	2388	80.4	48	59	65	2080	940
148	8	2703	90.9	55	67	73	2330	1060
194	4	2882	97.4	58	78	78	2030	920
195	5	3486	117.7	71	95	95	2390	1080
196	6	4091	138.0	83	111	111	2860	1300
197	7	4695	158.2	95	127	127	3260	1480
198	8	5300	178.5	107	144	144	3630	1650

Table 11. Bin Dimensions

MODEL NO.	NO. OF TIERS	DIMENSIONAL INFORMATION									
		A		B		C		D		E	
		ft	m	ft	m	ft	m	ft	m	ft	m
144	4	13.4	4.08	13.8	4.21	14.1	4.30	10.2	3.1	14.2	4.33
145	5							12.7	3.86	16.7	5.09
146	6							15.2	4.62	19.2	5.85
147	7							17.7	5.38	21.7	6.61
148	8							20.2	6.15	24.2	7.38
194	4	18.7	5.70	19.1	5.82	19.4	5.91	10.2	3.1	15.8	4.8
195	5							12.7	3.86	18.3	5.56
196	6							15.2	4.62	20.8	6.32
197	7							17.7	5.38	23.3	7.09
198	8							20.2	6.15	25.8	7.85

Note

1. Capacities shown include 30° roof cone.
2. Based on 1.244 cu. ft per bu. and 5% compaction below eaves line
3. Based on 1 cu. ft = 0.0283 m³ and 5% compaction below eaves line
4. 1kg = 2.205 lb; 1 tonne = 1000 kg

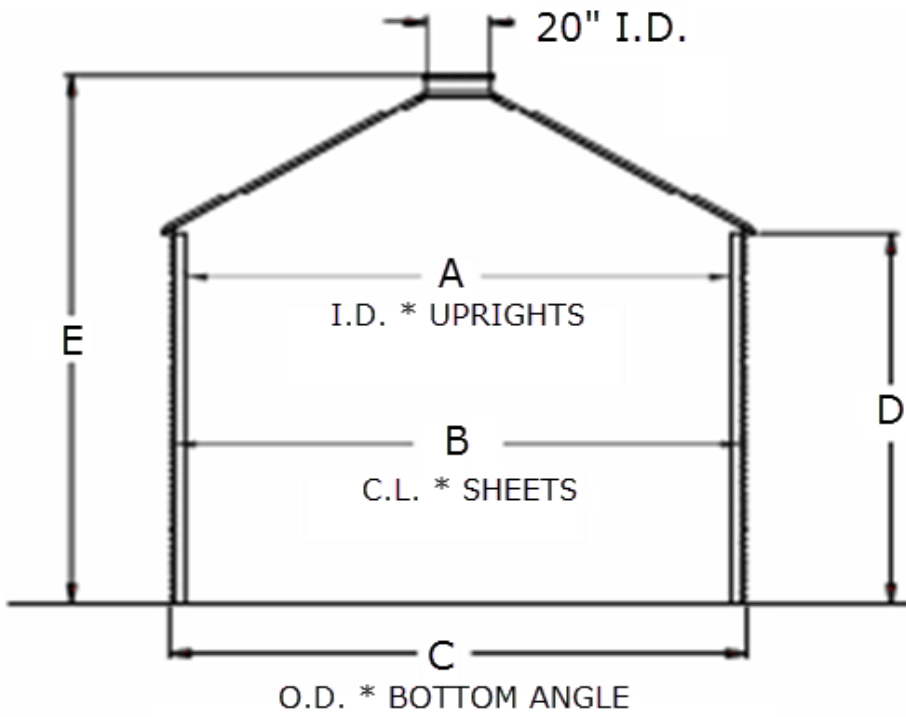

- * I.D = Inside Dimension between uprights
- * C.L. = Center Line to Center Line of corrugation
- * O.D. = Outside to Outside of corrugation

7. Appendix

7.1. Materials List - Flat Bottom Bins

Table 12. Models 144 to 148

Description	Part No.	144	145	146	147	148
Remote Cap Opener	235514	1	1	1	1	1
Fill Cap Assembly	236060	1	1	1	1	1
Roof Sheet	235601	23	23	23	23	23
Roof Sheet c/w Inspection Hatch	235613	1	1	1	1	1
Roof Ladder Assembly	235615	1	1	1	1	1
Full Bin Indicator	235170	1	1	1	1	1
Wall Sheet Bundle 144	236124	1				
Wall Sheet Bundle 145	236125		1			
Wall Sheet Bundle 146	236126			1		
Wall Sheet Bundle 147	236127				1	
Wall Sheet Bundle 148	236128					1
Top Ring Angle	236123	4	4	4	4	4
Bottom Ring Angle	236122	4 *	4 *	4 *	4 *	4 *
Upright .101 x 62.5	236779	2	2	1		
Upright .101 x 91.5	236538			4		
Upright .101 x 122	236540	3			4	
Upright .101 x 122 Special	236541				1	
Upright .101 x 152	236542		4			4
Upright .101 x 152 Special	236543					1
Upright .131 x 122	236340			3	4	4
Upright .131 x 122 Special	236341			1	1	1
Walk-in Door Assembly	235100	1	1	1	1	1
Auger Chute Package	235125	1	1	1	1	1
Hardware Pail	235497	1	1			
Hardware Pail	235498			1		
Hardware Pail	235499				1	1

* For bin models 235998 to 236002 for Sealform, no Bottom Ring Angle (236122) is provided

Table 13. Models 194 to 198

Description	Part No.	194	195	196	197	198
Remote Cap Opener	235514	1	1	1	1	1
Fill Cap Assembly	236060	1	1	1	1	1
Roof Sheet	235602	23	23	23	23	23
Roof Sheet c/w Inspection Hatch	235614	1	1	1	1	1
Roof Ladder Assembly	235616	1	1	1	1	1
Full Bin Indicator	235170	1	1	1	1	1
Wall Sheet Bundle 194	236129	1				
Wall Sheet Bundle 195	236130		1			
Wall Sheet Bundle 196	236131			1		1
Wall Sheet Bundle 197	236132				1	
Wall Sheet Bundle 198 Makeup	236133					1
Top Ring Angle	236223	6	6	6	6	6
Bottom Ring Angle	236220	6 *	6 *	6 *	6 *	6 *
Upright .101 x 62.5	236779	2	2	1		
Upright .101 x 91.5	236538			6		
Upright .101 x 122	236540	3			5	
Upright .101 x 122 Special	236541				1	
Upright .101 x 152	236542		4			5
Upright .101 x 152 Special	236543					1
Upright .131 x 122	236340			5	6	6
Upright .131 x 122 Special	236341			1	1	1
Walk-in Door Assembly	235100	1	1	1	1	1
Auger Chute Package	235125	1	1	1	1	1
Hardware Pail	235500	1	1		1	1
Hardware Pail	235501			1		
Hardware Pail	235502			1	1	1

* For bin models 236006-236007 for Sealform, no Bottom Ring Angle (236220) is provided

7.2. Materials List - Cone Mount Bins

Table 14. Models 144 to 148 (Without Door)

Description	Part No.	144	145	146	147	148
Remote Cap Opener	235514	1	1	1	1	1
Fill Cap Assembly	236060	1	1	1	1	1
Roof Sheet	235601	23	23	23	23	23
Roof Sheet c/w Inspection Hatch	235613	1	1	1	1	1
Roof Ladder Assembly	235615	1	1	1	1	1
Full Bin Indicator	235170	1	1	1	1	1
Wall Sheet Bundle 144	265367	1				
Wall Sheet Bundle 145	265368		1			
Wall Sheet Bundle 146	265369			1		
Wall Sheet Bundle 147	236127				1	
Wall Sheet Bundle 148	236128					1
Wall Sheet .038 x 42.5 Short	236116				1	
Wall Sheet .049 x 42.5 Short	236112				1	2
Top Ring Angle	236123	4	4	4	4	4
Upright .101 x 91.5	236538			4		
Upright .101 x 122	236540	3			5	
Upright .101 x 152	236542		4			5
Upright .131 x 122	236340			4	5	5
Hardware Pail	235497	1	1			
Hardware Pail	235498			1		
Hardware Pail	235499				1	1
Caulking Box – 4 x 300 ml Tubes *	170448	1	1	1	1	1

* Tube Caulking supplied to seal wall sheet to hopper connection

Table 15. Models 194 - 198 (Without Door)

Description	Part No.	194	195	196	197	198
Remote Cap Opener	235514	1	1	1	1	1
Fill Cap Assembly	236060	1	1	1	1	1
Roof Sheet	235602	23	23	23	23	23
Roof Sheet c/w Inspection Hatch	235614	1	1	1	1	1
Roof Ladder Assembly	235616	1	1	1	1	1
Full Bin Indicator	235170	1	1	1	1	1
Wall Sheet Bundle 194	265370	1				
Wall Sheet Bundle 195	265371		1			
Wall Sheet Bundle 196	265372			1		1
Wall Sheet Bundle 197	265373				1	
Wall Sheet Bundle 198 Makeup	265374					1
Top Ring Angle	236223	6	6	6	6	6
Upright .101 x 91.5	236538			6		
Upright .101 x 122	236540	3			6	
Upright .101 x 152	236542		4			6
Upright .131 x 122	236340			6	6	6
Hardware Pail	235500	1	1		1	1
Hardware Pail	235501			1		
Hardware Pail	235502			1	1	1
Caulking Box – 5 x 300 ml Tubes	170449	1	1	1	1	1

* Tube Caulking supplied to seal wall sheet to hopper connection

7.3. Materials List - Hardware Pails & Door

Table 16. Hardware Pails

DESCRIPTION	PART NO.	SERIES 14			SERIES 19		
		235497	235498	235499	235500	235501	235502
HFS ¼ x ¾ c/w WASHER – Bag of 150	235900	1	1	1	1	1	
HFS ¼ x ¾ c/w WASHER – Bag of 75	235901				1	1	
HFS ¼ x 2¼ c/w WASHER – Bag of 25	235903	1	1	1	1	1	
HEX NUT ¼ – Bag of 125	235905	1	1	1	2	2	
HEX FLANGE NUT ¼ – Bag of 50	235907	1	1	1	1	1	
HFS 3/8 x ¾ c/w WASHER – Bag of 175	235930	2	2	3	4	2	1
HFS 3/8 x ¾ c/w WASHER – Bag of 55	235931	2	2	2		1	2
HFS 3/8 x 1 c/w WASHER – Bag of 175	235932	1	1	2	1	1	1
HFS 3/8 x 1 c/w WASHER – Bag of 55	235933		2				
HFS 3/8 x 1½ c/w WASHER – Bag of 55	235935	1	1	1	1	1	
HEAVY HEX NUT 3/8 – Bag of 300	235952	2	2	3	3	2	1
HEAVY HEX NUT 3/8 – Bag of 50	235953	2	4	3			4
FLAT WASHER 3/8 – Bag of 75	235957	2	2	2	2	2	
FLAT WASHER 3/8 – Bag of 35	235958				1	1	1
UPRIGHT BASE PLATE	236545	6	5	5	6	6	1
DOOR TIE BACK CHAIN (17.75")	195695	1	1	1	1	1	
ARDOX NAIL 1½ GALVANIZED	155913	7	7	7	7	7	
CAULKING - 40' ROLL	193814	2	3	3	3	2	1
EAVE CLOSURE 14' (SET OF 24)	235651	1	1	1			
EAVE CLOSURE 19' (SET OF 24)	235652				1	1	
INSPECTION HATCH BULB GASKET	235623	1	1	1	1	1	
SELF-DRILL SCREW #12x7/8 c/w WASHER	900463	45					
MANUAL – SERIES 14 & 19	198818	1	1	1	1	1	

Table 17. 235100 Walk-In Door Components

DOOR FRAME & PANEL WELDMENT	235101	1
INSIDE JAMB	235111	4
TIE BAR ASSEMBLY	235106	1
AUGER CHUTE COVER ASSEMBLY	235138	1
LEFT HAND AUGER CHUTE SIDE ASSEMBLY	235128	1
RIGHT HAND AUGER CHUTE SIDE ASSEMBLY	235129	1
DOOR SPACER SHEET	236790	1
DOOR BOARD ASSEMBLY	235109	1

7.4. Hardware Usage

Table 18. Roof Hardware

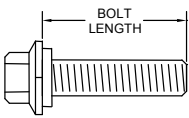
	1/4" x 3/4" Flanged Hex Bolt (Washer)	1/4" x 2-1/4" Flanged Hex Bolt (Washer)	1/4" Flanged Lock Nut	1/4" Hex Nut	3/8" x 3/4" Flanged Hex Bolt (Washer)	3/8" x 1" Flanged Hex Bolt (Washer)	3/8" Heavy Hex Nut	3/8" Flat Washer
	235900 (150) 235901 (75)	235903 (25)	235907 (50)	235905 (125)	235930 (175) 235931 (55)	235932 (175) 235933 (55)	235952 (300) 235953 (50)	235957 (75) 235958 (35)
TOP RING ANGLE to WALL SHEET					◆		◆	
TOP RING ANGLE JOINTS to WALL SHEET						◆	◆	◆
ROOF SHEET to VENT COLLAR	◆		◆					
CENTER OF ROOF SHEET to TOP RING ANGLE	◆			◆				
ROOF SHEET RIB to BIRD STOP to TOP RING ANGLE		◆	◆					
ROOF SHEET RIB to ROOF SHEET RIB	◆			◆				
ROOF LADDER ASSEMBLY to ROOF SHEET RIB	◆			◆				

Note

- — bins with doors
- ◆ — bins without doors

Table 19. Bin Hardware

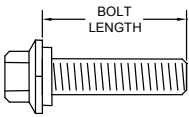
	5/16" x 3/4" Flanged Hex Bolt (Washer)	5/16" Hex Nut	5/16" Square Nut	3/8" x 3/4" Flanged Hex Bolt (Washer)	3/8" x 1" Flanged Hex Bolt (Washer)	3/8" Heavy Hex Nut	3/8" Flat Washer	7/8" Self Drilling Screw
	193801	193729	193910	235930 (175) 235931 (55)	235932 (175) 235933 (55)	235952 (300) 235953 (50)	235957 (75) 235958 (35)	900463 (45)
WALL SHEET to WALL SHEET				◆◆		◆◆		
UPRIGHT to WALL SHEET (WASHER at SLOTS)					◆◆	◆◆	◆◆	
UPRIGHT to WALL SHEET (1405)					◆◆	◆◆		◆
UPRIGHT to UPRIGHT (146-148, 196-198)					●	●	●	
UPRIGHT to TOP RING ANGLE					◆◆	◆◆	◆◆	
UPRIGHT to BOTTOM RING ANGLE					●	●	●	
WALL SHEET to BOTTOM RING ANGLE					●	●		
BOTTOM RING ANGLE JOINTS to WALL SHEET					●	●	●	
BIN WALL to HOPPER ASSEMBLY					◆	◆	◆	
DOOR JAMB to WALL SHEET					●	●		
DOOR SILL & HEADER to WALL SHEET					●	●	●	
AUGER CHUTE to TIE BAR	●	●						
AUGER CHUTE COVER to CHUTE SIDES	●		●					
AUGER CHUTE COVER HANDLE	●	●						
DOOR TIE BACK to WALL SHEET					●	●		

Note

- — bins with doors
- ◆ — bins without doors

7.5. Recommended Bolt Assembly

When tightening bolts, tighten the nut on the bolt until a “snug-tightened condition” has been achieved. A “snug-tightened condition” is defined in *Specification for Structural Joints Using ASTM A325 or A490 Bolts* (Research Council on Structural Connections: June 2004), which states:







*“The snug-tightened condition is the tightness that is attained with a few impacts of an impact wrench or the full effort of an ironworker using an ordinary spud wrench to bring the connected plies into **firm contact.**”*

A properly tightened bolt will compress the sealing washer noticeably. All assembly crew members must be made aware of this requirement, and must know how to achieve a snug-tightened condition using common bin-building tools.

It is important that the bolts in the vertical wall sheet seams are tightened enough to squeeze the caulking and bring the wall sheet surfaces into firm contact with each other. This is especially important to monitor when installing bolts in temperatures approaching -10°C (14°F).

The following table shows the minimum impact gun torque capacity necessary to achieve a snug-tightened condition for bolts used in the assembly process.

Table 20. Recommended Impact Gun Torque Values Capacity to Achieve Snug-Tightened Bolts

Bolt Diameter	Bolt Grade	Grade Mark	Recommended Torque Capacity		
			in-lb	ft-lb	N-m
1/4"	Grade 8.2		75	6	8
5/16"	Grade 8.2		215	18	24
3/8"	Grade 8.2		370	31	42
7/16"	Grade 8.2		600	50	68
1/2"	Grade 8.2		960	80	108
5/8"	Grade 8.2		1800	150	203
3/4"	Grade 5		3230	269	365

For proper sealing, do not overtighten the wall seam connections. Sealing is not critical on upright splice connections; these connections should be tightened securely to prevent loosening.

Hold the bolt head securely when tightening the nut to prevent damage to the sealing washer.

Important

ALWAYS TIGHTEN THE NUT, NOT THE BOLT.

Avoid bin assembly at temperatures below -10°C (14°F) if possible. Erection in low temperatures does not ensure strong, well sealed connections. Do not substitute bolts in place of those supplied by Westeel.

8. Limited Warranty: Westeel Grain Bin Products

Westeel – Ag Growth International ("Westeel") warrants products that it has manufactured and/or that are branded with its name (the "goods") subject to the following terms and limitations, (the "warranty"):

Duration of Warranty

This warranty will run from the date of purchase from the dealer or distributor, authorized by Westeel. The duration of the warranty is limited as follows:

Galvanized Bins	5 years
EasyFlow2	24 months
Westeel Fans	36 months
Floors	12 months
Catwalk	12 months
Bulk Feed Tanks	24 months
SeedStor-K Cones	
Paint	12 months
Structural	30 months
Elite Cones	
Paint	30 months
Structural	10 years
WESTEEL cones	
Paint	No Warranty
Structural	12 months
Smooth Wall Bins	
Paint	60 months
Structural	10 years
Commercial Smooth Wall Bins	
Paint	12 months
Structural	10 years

Limitation of Remedies Replacement

Within the warranty period, Westeel will replace the goods and/or original manufactured components thereof which are found, to Westeel's satisfaction, to be defective. Westeel is not responsible for direct, indirect, special, consequential, or any other damages of any kind, including personal injury to any individual, howsoever caused, including caused by transportation of the goods for repair or replacement.

Procedure for Obtaining Service

In the event of a warranty claim, the purchaser must complete any and all information required by Westeel in order to properly assess or investigate the claim. Westeel will not be responsible for the removal of any of the goods found to be defective, or transportation charges to and from Westeel's authorized dealer or distributor, or for installation of any replacement goods and/or parts furnished under the warranty.

Limitations as to Scope of Warranty

The warranty does not extend to defects or damage caused, in whole or in part, by:

1. use of a kind and/or to a degree not reasonably expected to be made of the goods;
2. improper storage of the goods both prior to and after purchase;
3. damage caused by, or in the course of, installation or assembly;
4. any use of the goods which is not an intended use as specified in Westeel's published product literature, or otherwise specified by Westeel in writing;
5. any equipment attached to or used in conjunction with the goods;
6. any field modifications or substitutions to original bin components;
7. inadequate ventilation or any other circumstance not in keeping with proper maintenance and/or use of the goods;
8. Acts of God, accident, neglect or abuse of the goods by the purchaser and/or any other individual or entity; or
9. Any use or installation inconsistent with Westeel's Standard Disclaimers.

Limitations as to Manufacturer

The warranty does not cover products sold by Westeel that are not manufactured by Westeel. In those circumstances, the purchaser is referred to the manufacturer of those products.

Limitation of Implied Warranties and Other Remedies

To the extent allowed by law, neither Westeel nor its dealers, nor any company affiliated with Westeel makes any warranties, representations, or promises as to the quality, performance, or freedom from defect of any Product covered by this Warranty.

WESTEEL HEREBY DISCLAIMS, TO THE EXTENT APPLICABLE, ANY AND ALL IMPLIED WARRANTIES OF MERCHANTABILITY AND FITNESS FOR A PARTICULAR PURPOSE. A PURCHASER'S ONLY REMEDIES IN CONNECTION WITH THIS WARRANTY ARE THOSE SET FORTH IN THIS WARRANTY. IN NO EVENT WILL WESTEEL, ITS DEALERS, OR ANY COMPANY AFFILIATED WITH WESTEEL BE LIABLE FOR INCIDENTAL, CONSEQUENTIAL OR PUNITIVE DAMAGES.

Some jurisdictions do not allow waivers of certain warranties, so the above waivers may not apply to you. In that event, any implied warranties are limited in duration to ninety (90) days from delivery of the products. You may also have other rights which vary from jurisdiction to jurisdiction.

Exclusive Warranty

This warranty is the only warranty provided by Westeel and all other warranties and/or commitments, whether express or implied and no matter by whom made, statutory or otherwise, are subsumed and replaced by it and are of no legal effect. If any provision of the warranty is held by a court of

competent jurisdiction to be void or unenforceable, in whole or in part, such provision shall be deemed severable and will not affect or impair the legal validity of any other provision of the warranty.



450 Desautels Street
P.O. Box 792
Winnipeg, Manitoba, R3C 2N5 Canada
Phone: (866) 299-4312
Fax: (204) 235-0796

Website: www.westeel.com
Email: info@westeel.com
©Ag Growth International Inc. 2019
Printed in Canada

If you have any comments or questions on this manual, or find an error, email us at comments@aggrowth.com.
Please include the part number listed on the cover page in your message.
