

Rev. 00/00

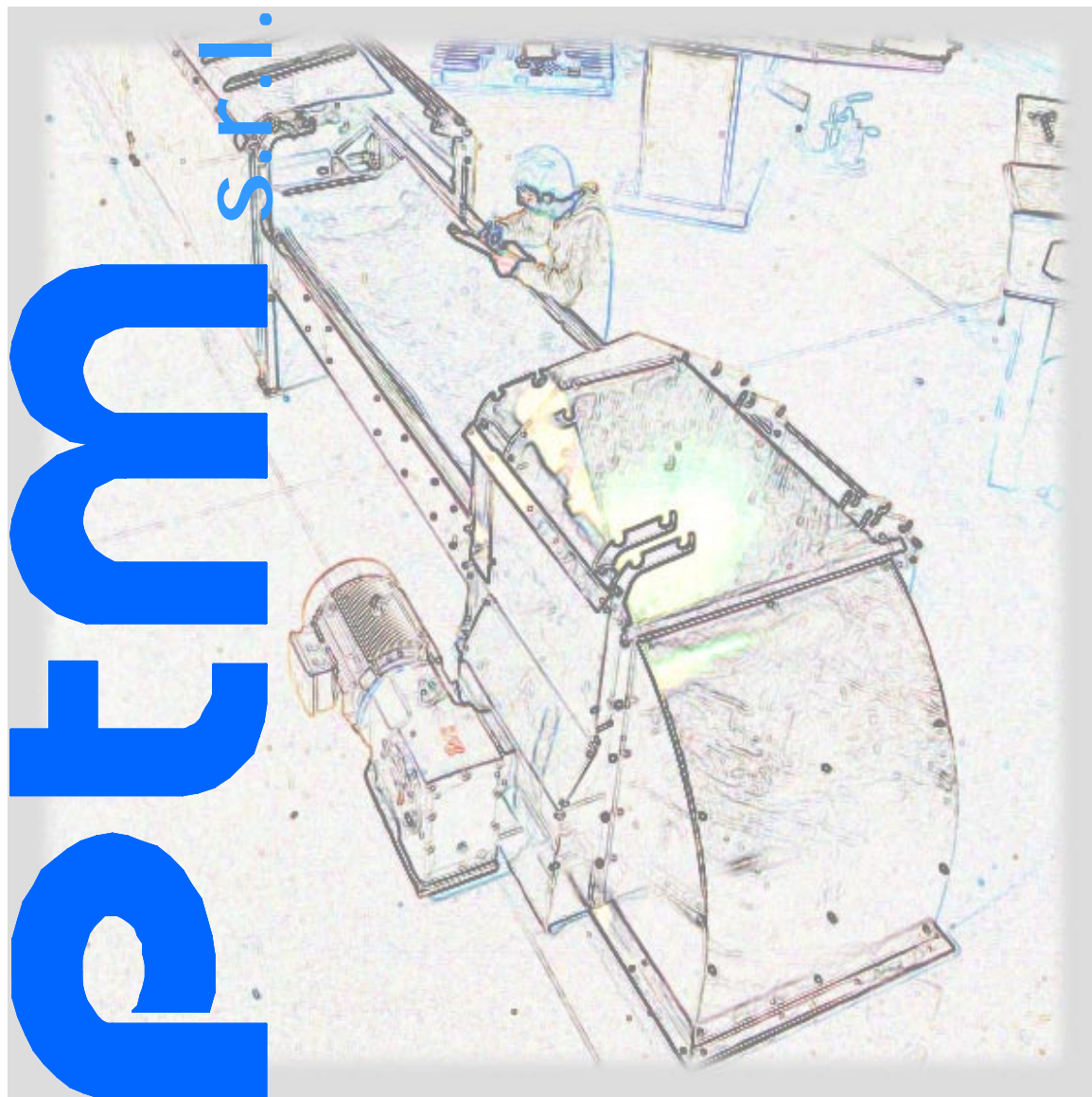

Series TNM Belt conveyor

SERIES TNM BELT CONVEYOR

The *TNM Series* belt conveyors represent the synthesis of the most modern and effective manufacturing principles, in matters of transporting granular and powdery products in general and cereals, oleaginous seeds and their by-products in particular. Their use is especially advantageous in the case of very long runs, for the transport of delicate products, or, in the cases in which it is preferred to avoid contamination problems between the various parts of the product to be transported.

Their design took into account the most rigorous standards in matters of reliability, safety and accident prevention so as to satisfy all the job demands in the most diverse of industrial sectors.

The high standards of quality, both in the design as well as in the construction, are guarantees of correct working, even in the heaviest working conditions, with complete respect for the transported product, contained energy consumptions and low maintenance costs.

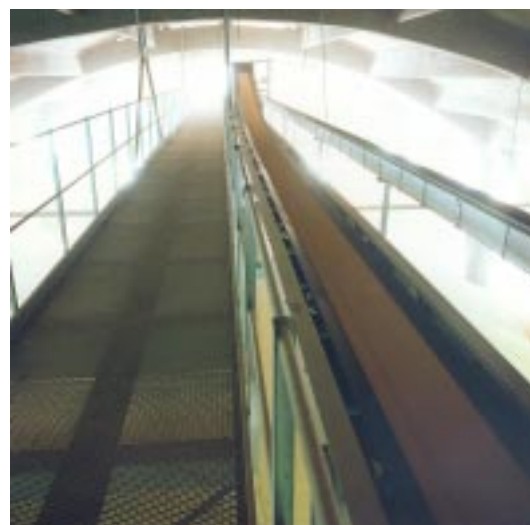

RANGE

The *TNM Series* belt conveyors have been divided into 3 series and 8 models to offer a very extensive range of proposals. The nominal capacities, referred to as belt speeds suitable for the characteristics of each product, are recorded on the following table.

MODEL	WHEAT (0,75 t/m ²)	SOYA BEANS (0,70 t/m ²)	SUN FLOWER (0,40 t/m ²)	RICE (0,60 t/m ²)	CEREALS FLOURS (0,50 t/m ²)	BRAN (0,25 t/m ²)	BY-PRODUCTS (0,35 t/m ²)	MEAT FLOURS (0,60 t/m ²)
<i>Belt's ref. Speed (m/sec)</i>	2,80	2,80	2,80	2,50	2,50	2,50	2,50	2,50
TNM 340/ 300	40	40	20	30	30	10	20	30
350	60	60	30	50	40	20	30	50
450	100	100	60	80	70	30	50	80
TNM 500/ 600	200	200	100	150	120	60	80	150
650	250	250	120	180	150	80	100	180
750	300	300	180	250	200	100	150	250
TNM 630/ 1000	600	560	320	-	-	-	-	-
1200	1000	1000	500	-	-	-	-	-

Each series is characterized by a specific diameter of the towing drum and by a particular carpentry structure, designed to satisfy the most varied of installation requirements.

CHARACTERISTICS		TNM 340	TNM 500	TNM 630
Ø towing drum	mm.	340	500	630
Ø return drum	mm.	220	220	320
Ø counterweight drums	mm.	220	220	320

However, for the models, the main distinctive specifications are represented by the diameter of the rollers and by the width of the belt.

CHARACTERISTICS		TNM 340/			TNM 500/			TNM 630/	
		300	350	450	600	650	750	1000	1200
Ø nominal rollers	mm.	60	60	76	90	90	90	110	110
Belt width	mm.	300	350	450	600	650	750	1000	1200

The configuration of the upper stations, that is the number, the dimensions and the arrangement of the outgoing rollers, determines the theoretical maximum section of the transported product which, obviously, also changes depending on the typical dynamic overload angle of each product.

The following table reports, for each model, the specifications of the upper stations and the maximum section of the transported product with reference to the grain (rest angle: 28° - dynamic overload angle: 10°).

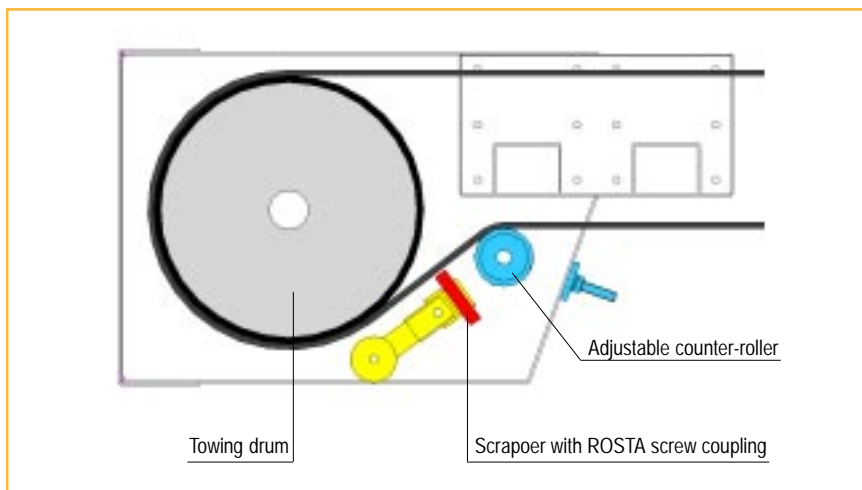

The bearings provided, up to a maximum shaft diameter of 80 mm, are the rigid radial balls-type and are mounted on a suitable revolving support in cast iron. For diameters greater than 80 mm (or for special applications), radial revolving roller bearings with a traction bush are installed, mounted on upright supports in 2/2 in cast iron. In any event, the bearings and supports are bought from the most well-known manufacturing firms. The following card records the types of bearing normally used (unless momentarily unavailable on the market) and the fields of application of the various series of machines.

FIELDS OF APPLICATION			Ø SHAFT mm.	Radial bearings on revolving supports	Revolving radial roller bearings on upright supports in 2/2 in cast iron	
TNM 340	TNM 500	TNM 630			SKF	SKF
					Bearing	Support
			50	SY 50 TF		
			60	SY 60 TF		
			70	SYJ 70 TF	22316 CCK/W33	SNA 516 TC
			80	SYJ 80 TF	22218 CCK/W33	SNA 518 TC
			90		22220 CCK/W33	SNA 520 TC
			100		22222 CCK/W33	SNA 522 TC
			110		22224 CCK/W33	SNA 524 TC
			125		22228 CCK/W33	SNA 528 TC

The generation of power occurs by means of a gear motor unit which transmits the motion to the towing drum. The command is usually directly combined with the shaft. The dimensioning of the command unit and the choice of the applicable solution depend on the required capacity, on the machine's length and inclination and the belt's speed of advancement^(*). The command's assembly, in any case, can be provided indifferently on either the right or the left, and the preparation of the applicable solution is done in relation to the brand and manufacturing shape of the chosen gear motor unit.

(*) To ensure a gradual start up, especially in the presence of the belt tensioning system with a counterweight, it is suggested that a "soft start" system is installed in the electrical control panel.



FOOT

The return foot is produced in shaped sheet metal panels that are bolted to each other in order to give remarkable sturdiness and rigidity to the structure, the main specifications of which are recorded on the side card.

CHARACTERISTICS		TNM 340	TNM 500	TNM 630
Sides thickness	mm.	3,0	3,0	4,0
Spacer thickness	mm.	3,0	6,0	8,0
Hood thickness	mm.	3,0	3,0	4,0

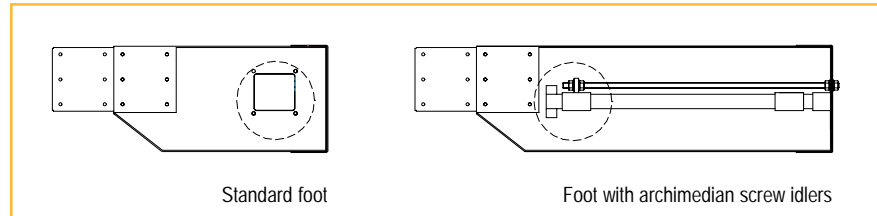

The machine has been designed in two versions - with and without Archimedean screw idlers. In the first case, the tensioning of the belt is done by means of a pair of Archimedean screw idlers which act on the return drum unit. Generally, this system is suitable for machines of limited length (side card) since the specifications of the large belts used and the functioning principle of these machines entail different manufacturing solutions to recover the belt's natural stretching and elasticity.

CHARACTERISTICS		TNM 340	TNM 500	TNM 630
Lenght max.	mt.	30	45	50

In the second case, the manufacturing of the foot is simplified since the belt's tensioning is produced by a suitable system with a counterweight.

The return drum is made up of a shell (suitably shaped) and two discs in very thick steel sheeting onto which the shaft is fixed. Even in this case the shell is convex so as to facilitate the self-centring of the belt.

The bearings are of the rigid radial ball-type mounted on a suitable revolving square flanged seat in cast iron. The side card records the type of bearings normally used (unless momentarily unavailable on the market) and the fields of application in the various series of machines.

Radial bearings on revolving supports SKF	Ø Shaft mm.	Fields of application		
		TNM 340	TNM 500	TNM 630
FYC 40 RM	40			
FYC 50 RM	50			
YAR 212 2F	60			
FYJ 80 TR	80			



BELT TENSIONING COUNTERWEIGHT

The belt's tensioning is carried out by means of a counterweight system, consisting of a triad of drums for the belt's return and of an overload basin, mounted on a pair of sliding bars. This system intervenes particularly in the machine's start up phase, when the belt tends to stretch, before the towing drum's complete grip.

The unit can be positioned at the most appropriate point of the conveyor, depending on the application's requirements. The size of the overload basin and the bars can vary depending upon the machine's length.

Special tensioning systems can be produced for particular requirements.

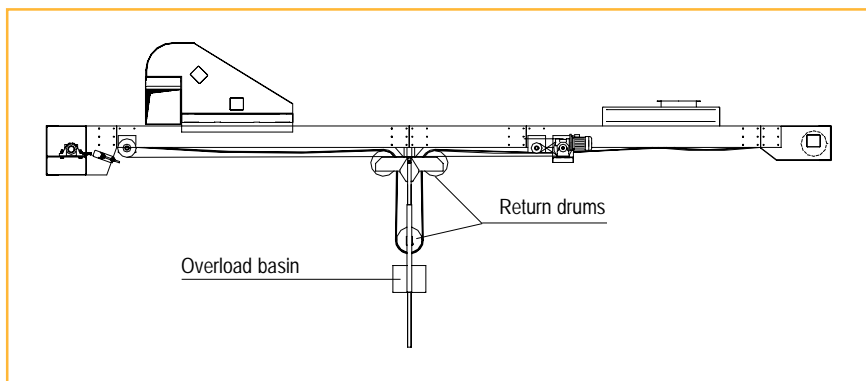

UPRIGHT SUPPORTS

The intermediate upright supports are produced with a pair of side frames in shaped sheet metal onto which the spacer elements are fixed, of varying number, depending on the step foreseen for the feed rollers. Each upright support is connected to the next by a suitable distance joint, which guarantees the machine's perfect alignment and a very quick and precise assembly.

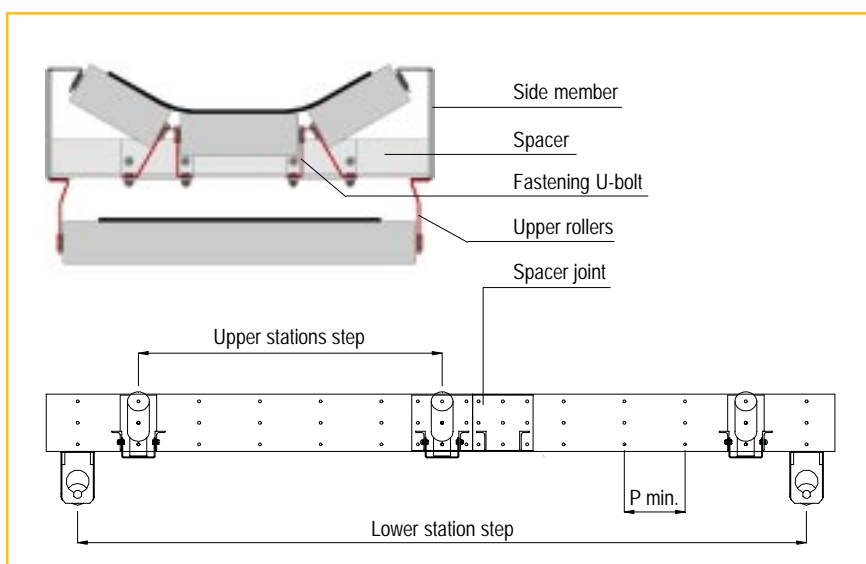

The following card records the main manufacturing specifications of the upright supports for the various series of conveyors. The feed rollers, due to a special profile of the side

CHARACTERISTICS		TNM 340	TNM 500	TNM 630
Side members thickness	mm.	3,0	3,0	5,0
Spacer plate thickness	mm.	3,0	6,0	8,0
Spacer thickness	mm.	3,0	5,0	6,0

frames and the way they have been drilled, can be positioned with a minimum step of 250 mm. The assembly is very simple, as they are fixed directly onto the side frames and on an adjustable U-bolt, provided on the spacer element. The return rollers, however, are mounted on some supports, and they too are adjustable, are manufactured in shaped sheet metal and are fixed to the side frames.

ROLLERS

The rollers have different specifications depending upon the series of belt conveyor, the type of product to be transported and on the installation conditions. They are all lubricated for life and are designed for use with powdery or granular products, at high speeds. Normally, 308 N or 309 N type rollers are mounted on precision bearings, which have well-known brands, with patented ERMEX C6 protections that have a labyrinth seal with wear and tear recovery. The temperatures of use, in a standard performance, are included between -10°C $+90^{\circ}\text{C}$. Upon request, rollers can be supplied with lubrication suitable for either high or low temperatures (including respectively between $+90^{\circ}\text{C}$ $+150^{\circ}\text{C}$ or -40°C and -10°C). The main manufacturing specifications of these rollers are recorded on the following card.

CHARACTERISTICS	TNM 340/			TNM 500/			TNM 630/	
	300	350	450	600	650	750	1000	1200
Series	308 N	308 N	308 N	308 N	308 N	308 N	309 N	309 N
Ø rollers mm.	60	60	76	89	89	89	108	108
Shell thickness mm.	3,0	3,0	3,0	3,0	3,0	3,0	3,5	3,5
Ø axle mm.	15	15	15	15	15	15	20	20
Cotter mm.	17	17	17	30	30	30	30	30
Bearing type	6202	6202	6202	6202	6202	6202	6204	6204
Weights:			-					
- upper rollers kg.	2,404	3,078	4,402	6,870	7,380	8,064	15,624	18,540
- lower roller kg.	2,548	3,109	4,250	6,055	6,442	8,002	14,057	17,776
Project duration ore	10.000	10.000	10.000	30.000	30.000	30.000	30.000	30.000

The TNM 500 and TNM 630 Series conveyors can also be equipped with RR20 type rollers, suitably designed for use with loose, powdery or granular materials, chemically aggressive, or, for installations in corrosive environments. They are manufactured in very thick PVC, with heads in resin reinforced with fibreglass.

The bearings, by the main brand names, are large measured to be long lasting. Life lubrication is ensured by special protections in which suitable lip seals form a grease chamber that encloses the bearing. A special air seal further protects the bearing from foreign objects such as dusts or liquids. The temperatures of use are included between -10°C and +50°C. The following card records the main manufacturing specifications of these rollers.

CHARACTERISTICS	TNM 340/			TNM 500/			TNM 630/	
	300	350	450	600	650	750	1000	1200
Series	-	-	-	308 N	308 N	308 N	309 N	309 N
Ø rollers mm.	-	-	-	90	90	90	110	110
Shell thickness mm.	-	-	-	6,7	6,7	6,7	8,2	8,2
Ø axle mm.	-	-	-	20	20	20	20	20
Cotter mm.	-	-	-	30	30	30	30	30
Bearing type	-	-	-	6204	6204	6204	6204	6204
Weights:			-					
- upper rollers kg.	-	-	-	4,494	5,106	5,696	9,051	10,731
- lower roller kg.	-	-	-	4,118	4,383	5,433	8,114	10,274
Project duration ore	-	-	-	30.000	30.000	30.000	30.000	30.000

The upper stations are generally mounted by using the steps recorded on the card on the side, it being understood that in correspondence to the feeding points or in the case of special applications, these steps are close. For the lower stations, however, the step is usually equal to 3000 mm.

CARATTERISTICHE	TNM 340	TNM 500	TNM 630
Standard upper stations step mm	1500	1250	1000
Standard lower stations step mm	3000	3000	3000



BELTS

The *TNM Series* belt conveyors provide for the possible use of different types of belt depending upon the product to be transported, on the dimensions of the machine and/or on the client's special requirements. The belts normally provided are manufactured with a centre in synthetic fibre (Polyester Nylon), have a high specific load and are resistant to atmospheric agents. These belts are particularly strong, very flexible and resistant to the fatigue from repeated flexions, have a high elasticity and are resistant to knocks and tears. A special treatment renders them safe from decomposition and therefore suitable for use outdoors and/or with damp or wet products. The compactness of the fabric pack and the reinforced borders ensure a high resistance to tearing and fraying. The FL type belts have a rubber coating that is smooth, abrasion and cut resistant, and they are particularly suitable for transporting cereals and their by-products. Their temperatures of use are included between -35°C and $+90^{\circ}\text{C}$. Their main manufacturing specifications are recorded on the following card.

CHARACTERISTICS		FL 200	FL 250	FL 315	FL 400	FL 500
Resistant inserts	nr.	2	2	3	3	4
Belt thickness	mm.	6,2	7,4	8,0	9,3	10,2
Width upper cover	mm.	3,0	4,0	4,0	5,0	5,0
Width lower cover	mm.	2,0	2,0	2,0	2,0	2,0
Weight	kg/m ²	7,4	8,8	9,6	11,0	11,9
Work load	kg/cm.	20	25	32	40	50
Working load strain	%	1,2	1,2	1,2	1,2	1,2
Antistatic		yes				
Abrasion resistant		yes				
Cut resistant		yes				
Damp resistance		excellent				
Oil resistant		no				

The OL type belts, however, have a rubber coating that is smooth with remarkable resistance characteristics against the aggressive actions of animal, vegetable and mineral oils and fats. They are also particularly resistant to aliphatic and light aromatic solvents and ensure, in any case, good resistance to atmospheric agents generally. They are suitable for transporting oleaginous seeds (soyabeans, sunflowers, etc.) and their by-products. Their temperatures of use are included between -15°C and $+80^{\circ}\text{C}$. The following card records their main manufacturing specifications.

CARATTERISTICHE		OL 200	OL 250	OL 315	OL 400	OL 500
Resistant inserts	nr.	2	2	3	3	4
Belt thickness	mm.	6,2	7,4	8,0	8,5	10
Width upper cover	mm.	3,0	4,0	4,0	4	5,0
Width lower cover	mm.	2,0	2,0	2,0	2,0	2,0
Weight	kg/m ²	7,5	8,9	9,6	9,8	12,1
Work load	kg/cm.	20	25	32	40	50
Working load strain	%	1,5	1,5	1,5	1,5	1,5
Antistatic		si				
Abrasion resistant		si				
Cut resistant		si				
Damp resistance		buona				
Oil resistant		si				

The main dimensional specifications of the FL and OL type belts are recorded on the following card.

CHARACTERISTICS		TNM 340/			TNM 500/			TNM 630/	
		300	350	450	600	650	750	1000	1200
Width	mm.	300	350	450	600	650	750	1000	1200
Belt weight type FL:									
- FL 200	kg/mt.	2,22	2,59	3,33	-	-	-	-	-
- FL 250	kg/mt.	2,64	3,08	3,96	5,28	5,72	6,60	-	-
- FL 315	kg/mt.	-	-	4,32	5,76	6,24	7,20	9,60	11,52
- FL 400	kg/mt.	-	-	-	6,60	7,15	8,25	11,00	13,20
- FL 500	kg/mt.	-	-	-	7,14	7,74	8,93	11,90	14,28
Belt weight type OL:									
- OL 200	kg/mt.	2,25	2,63	3,38	-	-	-	-	-
- OL 250	kg/mt.	2,67	3,12	4,01	5,34	5,79	6,68	-	-
- OL 315	kg/mt.	-	-	4,32	5,76	6,24	7,20	9,60	11,52
- OL 400	kg/mt.	-	-	-	5,88	6,37	7,35	9,80	11,76
- OL 500	kg/mt.	-	-	-	7,26	7,87	9,08	12,10	14,52

For special applications belts can be used that are suitable from foodstuff products to materials with high temperatures (with peaks of up to +180°C), or to hot and oily products. Woven herringbone belts can also be used that are suitable for the transport of non-oily or non-greasy materials with an incline of up to 40°. The belts provided, on the basis of the conveyor's specifications, are either open or closed ring endless belts. In the first case, the splicing is done during the course of operations, by specialized personnel, after the assembly of the belt, while, in the second case, the large belt is supplied already spliced^(*).

(*) *The closed ring solution is generally provided for the models of conveyor that are smaller and limited in length.*



ACCESSORIES

The *TNM Series* belt conveyors have a wide range of accessories to satisfy the most varied of uses, to check the correct functioning of the machine and for safety.

DISCHARGE TRIPPER

In order to unload the product at intermediate points along the conveyor, a remote controlled movable cart is provided complete with a maximum level sensor (the specifications of which are recorded on card) the function of which is to lift the belt and to create an intermediate offload at the point in which it has been stopped. It is manufactured in shaped sheet metal, with a pair of belt return drums and a hopper switch (with the outlet either on the left or right). For the *TNM 340 Series* conveyors, advancement is produced by means of towing by way of a cable connected to a fixed control unit (with a 0,37 gear motor) and a return pulley. For the other series of machines, advancement is obtained by a gear motor mounted on board the tripper itself.

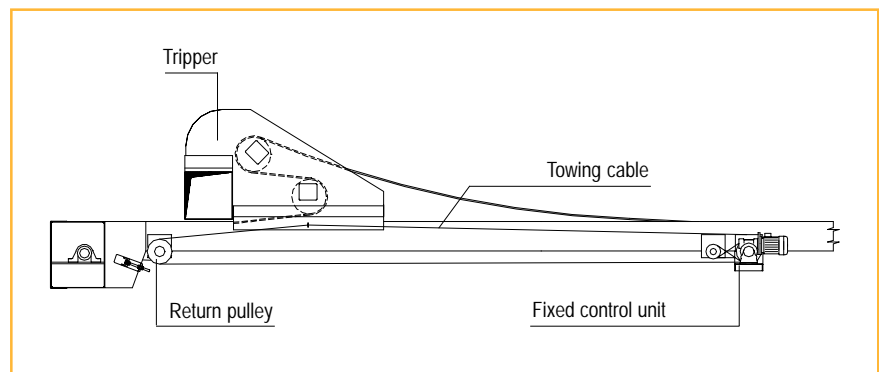
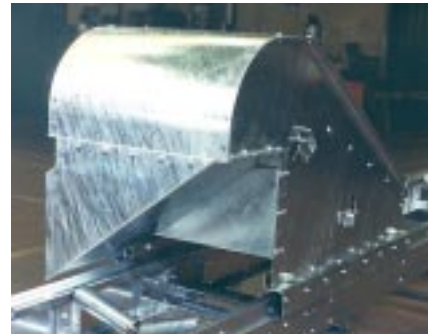

INLET HOPPER

The inlet hopper has been designed to ensure the collection of the product falling onto the conveyor belt, preventing any possible losses. The hopper, manufactured in shaped sheet metal, is supplied with suitable adjustable side seals and with two or more belt enclosing units, to be placed immediately

before and after the hopper.

The unit placed upstream gives the belt a more concave configuration for better handling of the falling product, while that unit placed downstream from the hopper has the task of releasing the belt only after stabilisation of the product. These units are provided with completely adjustable guide rollers and can be freely positioned on the upright supports, however, in correspondence with a spacer element.

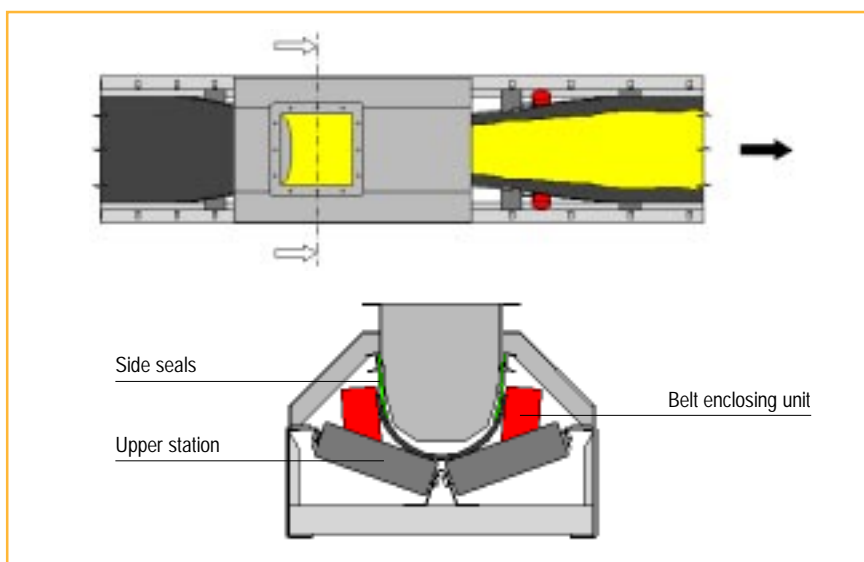

In the case of a wharf installation, a portable inlet hopper is provided (to be connected to the pickup conveyor of the discharge tower) that has a special spade to open the conveyor's two flaps.



SUPPORT FEET

In the case of a ground or platform installation, the conveyor can be equipped with suitable support feet, which can also have a variable distance, up to a maximum of 5,0 m.

COVER

The *TMM* Series conveyors are prepared with a cover system for protection against atmospheric agents. Such system provides a side buffer for the machine with panels in shaped sheet metal, fixed to the support feet, and an upper "vault" catch, manufactured with some of the elements in corrugated sheet steel, shaped appropriately. The upper elements are easy to dismount, so as to allow maintenance of the machine, due to an effective rapid shutdown system.



For a wharf installation, for pickup by the dock discharge towers, the upper cover has two flaps that can be opened to allow advancement of the inlet hopper. It is produced with a rubberised belt resting on a suitable supporting tubular structure and reinforced with elements in shaped sheet metal.

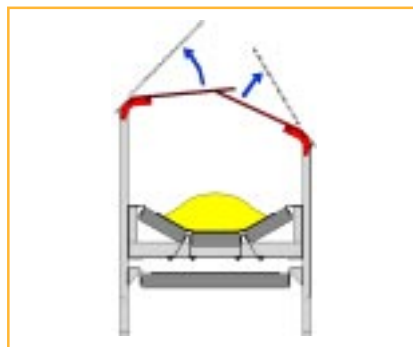

SAFETY SHUTDOWN

Since the *TMM* Series belt conveyors have been designed for long distances, a machine safety shutdown system has been designed which can be activated along its entire course. It is made up of a series of microswitches (the specifications of which are recorded on the following card) positioned under the carter and fixed to the conveyor's support feet, and are connected by means of a spring to a control cable mounted on the side of the conveyor. In the event of an emergency, the operator will operate on such cable - independently of the point where he is situated - to shutdown the machine..

DESCRIPTION	MODEL			
	10 mm.	10 mm.	10 mm.	10 mm.
Nominal carrying load	10 mm.	10 mm.	10 mm.	10 mm.
REFERENCES				
Type 3 wires D.C. PNP – 6...150 impulses /min.	XSA-V11373			
Type 3 wires D.C. PNP – 120...3000 impulses /min.	XSA-V12373			
Type 2 wires D.C. PNP – 6...150 impulses /min.		XSA-V11171	XSA-V11151	XSA-V11161
Type 2 wires D.C. PNP – 120...3000 impulses /min.		XSA-V12171	XSA-V12151	XSA-V12161
SPECIFICATIONS				
Connection type	cavo 3x0,34 mm ² lunghezza 2,0 m.		cavo 3x0,5 mm ² lunghezza 2,0 m.	
Degree of protection	IP 67			
Operating field	0...8 mm.			
Operating temperature	-25 ÷ +70 °C			
Signalling exiting status	LED USCITA			
Power supply	C.C. 10 ...58V	A.C. 24...48V (50-60Hz)	A.C. 110...120V (50-60Hz)	A.C. 220...240V (50-60Hz)
Voltage limits (including ripples)	C.C. 10...58V	A.C. 20...60V	A.C. 93...123V	A.C. 187...264V
Accumulated current	0...200 mA con protezione contro sovraccarichi e.c.c.	40...350 mA (2 A allo spunto)	40...350 mA (2 A allo spunto)	40...350 mA (2 A allo spunto)
Voltage drop, feedthrough status	= 1,8 V	= 4,5 V		
Residual current, non-feedthrough status	-	= 3,5 mA		
Absorbed current with no load	= 10 mA	-		
Maximum operating frequency	6000 pulses min. (for XSA-V11xxx) 48000 pulses min. (for XSA-V12xxx)			
DIMENSIONS				
Overall length	81 mm.			
Length of grooved section	57 mm.			
Diameter	M30x1,5			
Weight	0,300 Kg.			

REVOLUTIONS CONTROL SYSTEM

This system consists of a cam mounted on the shaft of the conveyor's foot, an induction-type proximity sensor and a protection carter. The sensor is calibrated in relation to the cam's revolutions under regular working conditions of the machine. In the event of the belt slackening or breaking, the return drum inevitably changes its revolutions and such change is immediately signalled by the sensor, which provides for the conveyor's immediate shutdown. The specifications of the sensors normally used are reported on the following card. However, it is possible to produce special applications for the Customer's required specifications.

GENERAL	
Model	XCK-P118
Description	Lever with plastic roller (1)
Working of the contacts	*N.C. N.A. rapid release unipolar
GENERAL SPECIFICATIONS	
Operating temperature	-25 ÷ 70 °C
Vibrations strength	25 g (from 100 to 500 Hz) in accordance with IEC 68-2-6
Impact strength	50 g in accordance with IEC 68-2-7
Electrical shocks protection	Class II in accordance with IEC 536 e NF C 20-030
Degree of protection	IP 65 in accordance with IEC 529; IP 653 in accordance with NF C 20-010
Mechanical duration	10 million handling cycles
Cables cavity	1 cavity for PG 11. Tightening capacity from 8 to 10 mm.
SPECIFICATIONS OF THE CONTACT ELEMENTS	
Nominal thermal current	10 A
Nominal insulation voltage	500 V A.C. and D.C. in accordance with IEC 158-1, NF C 20-040, VDE 0110 300V A.C. and D.C. in accordance with CSA C 22-2 n°14
Supply voltage	24 / 48 / 120 V in A.C. and D.C.
Insulation category	Group C in accordance with NF C20-040 and VDE 0110
Contacts operation	Rapid release upon switching on
Contact resistance	= 25 m?
Minimum operating force and torque	10 mm. from N
Clamps identification	In accordance with CENELEC EN 50013
Short-circuits protection	10 A fuse g1 or N in accordance with IEC 337-1B and VDE 0660-200
Repeatability accuracy	At 1 million handling cycles: 0,1 on the intervention points
Operating power	In accordance with IEC 337-1. Category of use AC-11 and DC-11 Frequency: 3600 handling cycles Gear factor: 0,5

(1) For operation with the cam at 30°. Max. speed = 1,5 m/Sec.

OUTLET HOPPER

Suitable connector hoppers with either a square or round section were devised for the head, shaped appropriately to ensure the maximum respect for the product. At the request of the Customer, they can be provided with an induction-type proximity sensor to prevent the problems tied to the clogging of the machine.



DIMENSIONS DATA

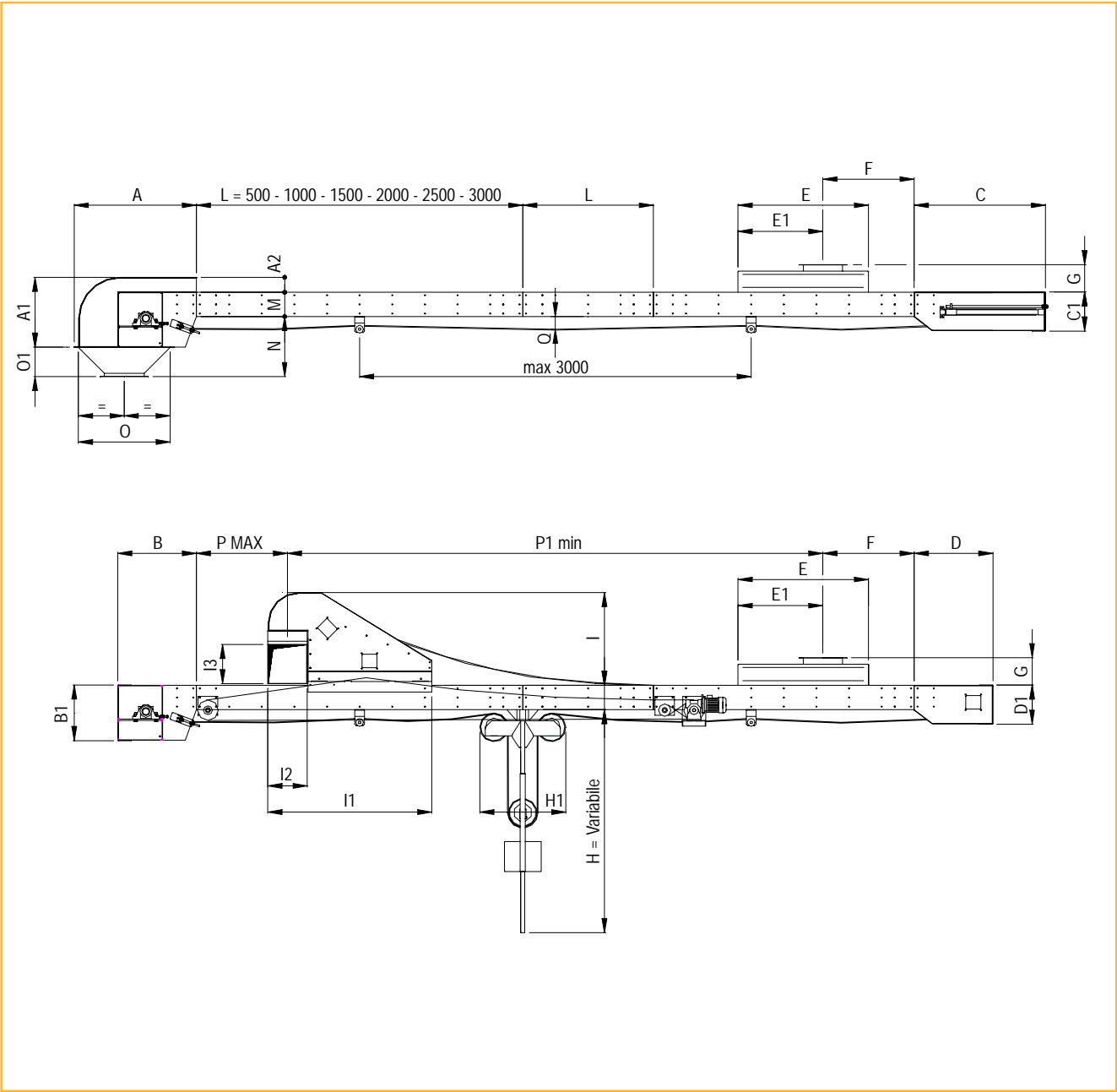

DIMENSIONS DATA

Series TNM Belt conveyor								
	TNM 340/			TNM 500/			TNM 630/	
	300	350	450	600	650	750	1000	1200
A	937			1266			1600	
A1	531			1178	1208	1263	1700	
A2	112			440			600	
B	600			780			800	
B1	410			683			1000	
C	1000			1250			1500	
C1	300			450			565	
D	600			750			1060	
D1	300			687			565	
E	1000			1500			2000	
E1	650			1000			1400	
F	450			650			950	
G	210			300			600	
H	700			1000			1500	
I	715			1400			1860	
I1	1250			2490			3500	
I2	295			350	350	450	600	
I3	295			450			750	
M	185			237			450	
N	530			1040			1500	
O	700			1000			1250	
O1	300			450			600	
P	500			1000			1500	
P1	4250			6300			8100	
Q	150			170			200	
R	160	200	300	300	350	350	500	600
S	435	525	616	821	886	974	1350	1560
T	300	350	450	600	650	750	1000	1200
V	98			176			325	
Z	482	572	663	921	986	1074	1700	1910
Ø	60	60	76	89	89	89	108	133
M	185			237			450	
X	750			790			835	
W	495			600			690	

DIMENSIONS DATA

Infeed section

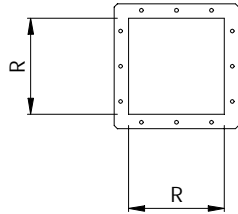

Discharge station

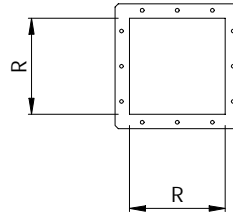

Upright supports section

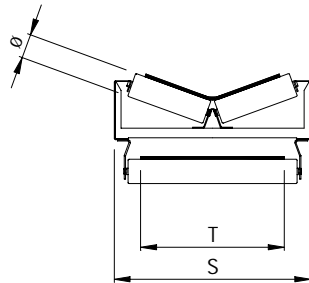

Upright supports section with cover

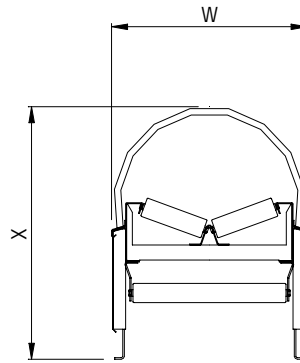

Inlet hopper section

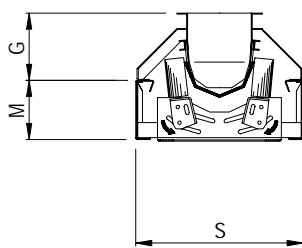

Discharge tripper section

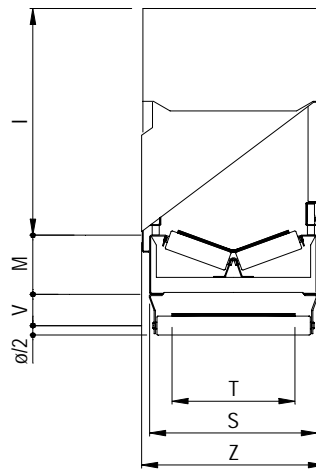

MODEL		Series TNM BELT CONVEYOR MAIN DIMENSIONS										
		R	S	T	V	Z	ø	M	G	I	X	W
TNM 300 /	300	160	435	300	98	482	60	185	210	715	750	495
	350	200	525	350		572						
	450	300	616	450		663						
TNM 500 /	600	350	821	600	176	921	89	237	300	1400	790	600
	650		886	650		986						
	750		974	750		1074						
TNM 630 /	1000	500	1350	1000	325	1700	108	450	600	1860	835	690
	1200	600	1560	1200		1910						



Produzione Tecnologie Marchetti

Legal and administrative seat

35042 ESTE (PD) - Viale dell'Industria, 17
Tel. ++39 0429 600 731 - 600 973
Fax ++39 0429 600 874

Fiscal data

P.IVA 00173960287
C.C.I.A.A. 0249648
Reg.Soc. TRIB. PD 44308/50189
Cap. Soc. Euro 52.000

Trade and technical service

35042 ESTE (PD) - Viale dell'Industria, 17
Tel. ++39 0429 600 749
Fax ++39 0429 600 874

Production factory

35042 ESTE (PD) - Viale dell'Industria, 17
Tel. ++39 0429 600 731 - 600 973
Fax ++39 0429 600 874

Other personal data

E-mail info@p-tm.it

RETAILER

A large, empty rectangular box with a thin black border, intended for the retailer's name and contact information.