

AGI GRAINMAXX

7400 Series

Portable Grain Auger Operator's Manual

This manual applies to:

AGI GrainMaxx: GMX 7485, GMX 7495, GMX 74105

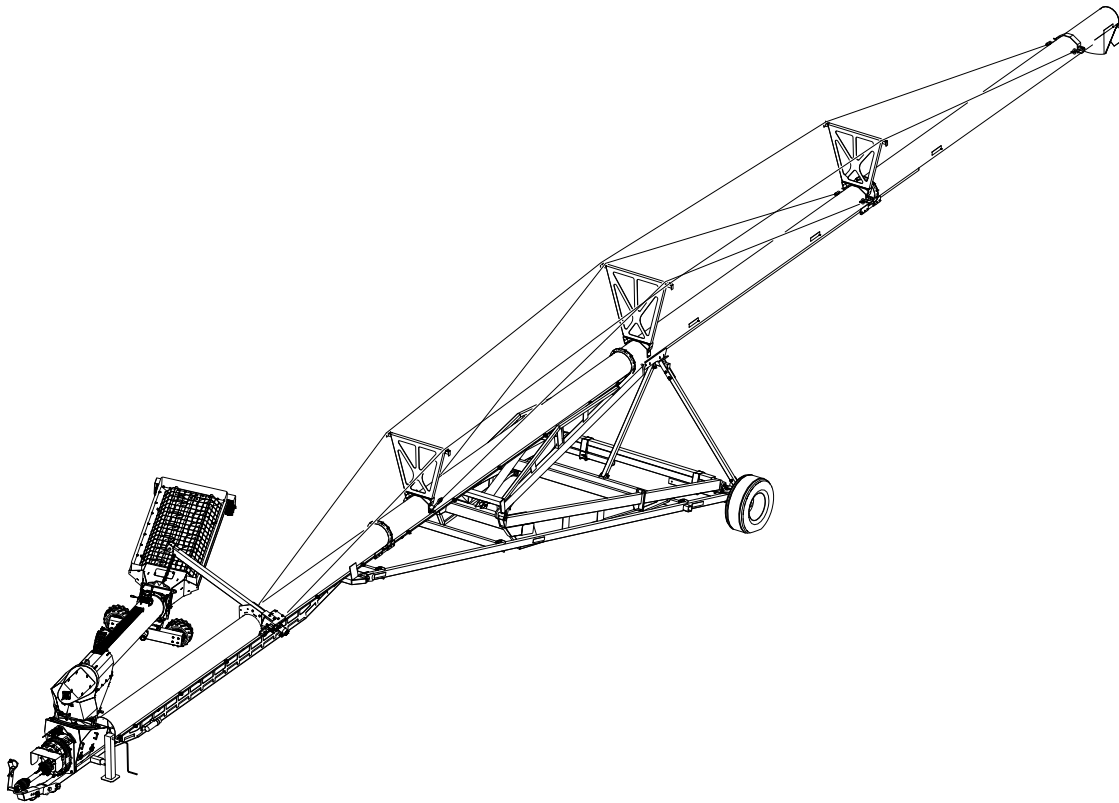

LOOKING FOR PARTS?

Check out our online
Parts Catalog!



Read this manual before using product. Failure to follow instructions and safety precautions can result in serious injury, death, or property damage. Keep manual for future reference.

Part Number: 8210-00024 R0

Revised: March 2021

Original Instructions

CONTENTS

1. Introduction	5
1.1 Serial Number Location	5
1.2 Intended Use	6
1.2.1 Misuse	6
2. Safety.....	7
2.1 Safety Alert Symbol and Signal Words.....	7
2.2 Follow Safety Instructions	7
2.3 Rotating Flighting Safety	8
2.4 Overhead Power Lines	8
2.5 Upending	8
2.6 Rotating Parts Safety.....	8
2.7 Work Area Safety	9
2.8 Guards Safety	10
2.9 Raising and Lowering the Auger	10
2.10 Hydraulic Winch Safety	10
2.11 Positioning the Auger.....	11
2.12 Towing the Auger	11
2.13 Drives and Lockout Safety.....	11
2.13.1 PTO Driveline Safety.....	12
2.13.2 Hydraulic Power Safety	13
2.14 Tire Safety.....	14
2.15 Personal Protective Equipment.....	14
2.16 Safety Equipment	15
2.17 Safety Decals	15
2.17.1 Decal Installation/Replacement.....	15
2.17.2 Safety Decal Locations and Details	15
3. Features.....	20
4. Transport.....	21
4.1 Transport Safety	21
4.2 Transport Preparation	22
4.3 Swing Away Transport Preparation	22
4.4 Preparing the Auger for Towing.....	24
5. Placement	25
5.1 Placement Safety.....	25
5.2 Positioning the Auger.....	25
5.2.1 Raising and Lowering	27
5.3 Extendable Axle Positioning.....	28
5.4 Auger-to-Tractor Hookup	29
5.5 Raising and Lowering the Intake Hopper.....	30
5.5.1 Swing-Away Hydraulic Winch Operation	31
5.6 Grain Hopper Positioning.....	31
5.6.1 Hydraulic Power Swing Operation	32
5.6.2 Telescoping Swing-Away Operation	32
6. Operation	34
6.1 Operation Safety	34

6.2 Start-up and Break-in	34
6.3 Operation - PTO Drive	35
6.4 Emergency Shutdown	36
6.5 Restarting with a Full Tube	36
6.6 Shutdown	37
6.7 Operating the Auger with Fertilizer	37
6.8 Storage.....	37
7. Maintenance	39
7.1 Maintenance Safety	39
7.2 Maintenance Schedule	39
7.3 Visually Inspect the Equipment.....	40
7.4 Lubricate the Equipment.....	41
7.4.1 Daily Grease and Lubrication	41
7.4.2 Periodic Grease Locations.....	42
7.5 Inspect Hydraulic Hoses and Fittings	45
7.6 Inspect and Service the Hydraulic Winch and Lift Cable	45
7.7 Oil and Adjust the Chain Drives	46
7.8 Check the Gearbox Oil Level	48
7.9 Change the Gearbox Oil	48
7.10 Clean and Wash the Equipment	48
7.11 Repack the Wheel Bearings with Grease.....	49
7.12 Check/Adjust the Truss Cables.....	50
7.13 Replace the Shear Bolt	52
8. Troubleshooting.....	53
9. Specifications	56
10. AGI GrainMaxx Limited Warranty	58

1. Introduction

Thank you for your purchase. Follow the instructions in this manual for safe use of this auger. Following proper operation and maintenance will help to keep the auger running in optimal condition.

Keep this manual handy for frequent reference and to review with new personnel. A sign-off form is provided on the inside front cover for your convenience. If any information in this manual is not understood or if you need additional information, please contact AGI or your representative for assistance.

This manual should be regarded as part of the equipment.

1.1. Serial Number Location

The serial number location for your auger is shown in the figure below. Have the serial number ready when ordering parts or requesting service or other information. Record information in the table below for easy reference.

Model Number	
Serial Number	
Date Received	

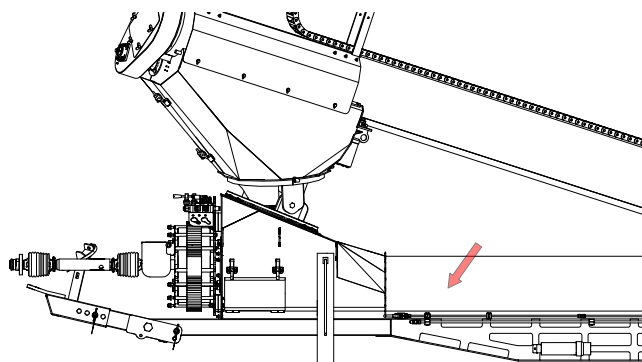



Serial No.: BA03B171900595

Model: Sample Text

Part No.: Sample Text

To register your product, Text keyword "Register" to 1.866.366.0708. Follow the instruction and send QR Code when prompted.

NOTE: Standard text message rates may apply. Contact your service provider.

TF: 1.877.667.7421 E: warranty@aggrowth.com

1.2. Intended Use

The auger is intended for use as listed below and described throughout this manual. Use in any other way is considered contrary to the intended use and is not covered by the warranty.

Intended use for the auger:

- Handling grain, pulse crops, treated seeds, or other similar materials.

1.2.1 Misuse

Do not install/use the auger for/with:

- transferring material other than dry, free-flowing food-grains.
- lifting or using as a hoist or crane.

2. Safety

2.1. Safety Alert Symbol and Signal Words





This safety alert symbol indicates important safety messages in this manual. When you see this symbol, be alert to the possibility of injury or death, carefully read the message that follows, and inform others.

Signal Words: Note the use of the signal words **DANGER**, **WARNING**, **CAUTION**, and **NOTICE** with the safety messages. The appropriate signal word for each message has been selected using the definitions below as a guideline.

 **DANGER** Indicates an imminently hazardous situation that, if not avoided, will result in serious injury or death.

 **WARNING** Indicates a hazardous situation that, if not avoided, could result in serious injury or death.

 **CAUTION** Indicates a hazardous situation that, if not avoided, may result in minor or moderate injury.

 **NOTICE** Indicates a potentially hazardous situation that, if not avoided, may result in property damage.

2.2. Follow Safety Instructions

Read and understand all safety instructions, safety decals, and manuals and follow them when operating or maintaining the equipment.

- Owners must give instructions and review the information initially and annually with all personnel before allowing them in the work area. Untrained users/operators expose themselves and bystanders to possible serious injury or death.
- Use for intended purposes only.
- Do not modify the auger in any way without written permission from the manufacturer and is not covered by the warranty.
- Follow a health and safety program for your worksite. Contact your local occupational health and safety organization for information.
- Follow applicable local codes and regulations.



2.3. Rotating Flighting Safety

DANGER

- KEEP AWAY from rotating flighting.
- DO NOT remove or modify flighting guards, doors, or covers. Keep in good working order. Have replaced if damaged.
- DO NOT operate the auger without all guards, doors, and covers in place.
- NEVER touch the flighting. Use a stick or other tool to remove an obstruction or clean out.
- Shut off and lock out power to adjust, service, or clean.



2.4. Overhead Power Lines

DANGER

- When operating or moving, keep auger away from overhead power lines and devices.
- The auger is not insulated.
- Electrocutation can occur without direct contact.



2.5. Upending

WARNING

- Anchor intake end and/or support discharge end to prevent upending.
- Intake end must always have downward weight. Do not release until attached to tow bar or resting on ground.
- Do not raise intake end above tow bar height.
- Empty the auger and fully lower before moving.

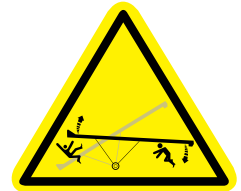

2.6. Rotating Parts Safety

WARNING

- Keep body, hair, and clothing away from rotating pulleys, belts, chains, and sprockets.
- Do not operate with any guard removed or modified. Keep guards in good working order.
- Shut off and lock out power source before inspecting or servicing machine.



2.7. Work Area Safety

- Have another trained person nearby who can shut down the auger in case of accident.
- The work area should be kept clear of bystanders, including children.
- Keep the work area clean and free of debris.

Figure 1. Auger Work Area

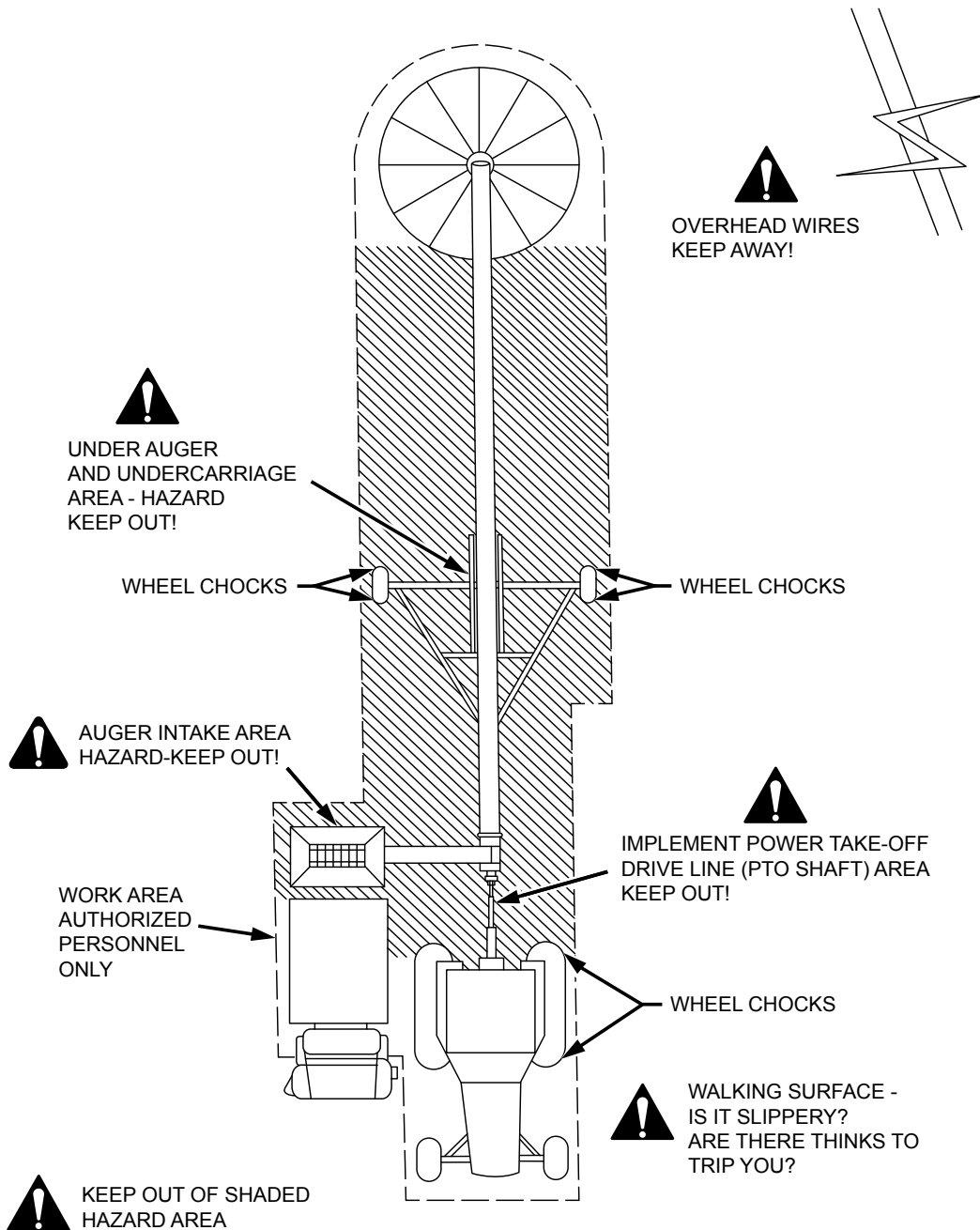

2.8. Guards Safety

- ⚠ WARNING**
- Keep guards in place. Do not operate with guard removed.
 - Do not walk on, step on, or damage guards.
 - Lock out power before removing a guard.
 - Ensure all guards are replaced after performing maintenance.

2.9. Raising and Lowering the Auger

- ⚠ WARNING**
- Before raising/lowering/moving/adjusting the auger, make sure the area around the auger is clear of obstructions and/or untrained personnel. Never allow anyone to stand on or beneath the auger when it is being placed.
 - Lower the auger to its lowest position when not in use.
 - Empty the auger before raising or lowering.
 - Do not get on or beneath the auger when raising or lowering.
 - Raise and lower auger on reasonably level ground only.
 - Never attempt to increase height of the auger by positioning wheels on lumber, blocks, or by any other means. To do so will result in damage to auger and/or serious injury.
 - Do not raise the auger in high winds.

2.10. Hydraulic Winch Safety

- ⚠ WARNING** When Equipped:
- Keep away from rotating cable drum and winch cable. Do not touch or grab cable while winch is being operated or use hands to guide the cable.
 - Inspect cable and cable clamps before using hydraulic winch. Replace cable if frayed or damaged. Tighten cable clamps if necessary.
 - Check the cable anchor on the winch drum is tight.
 - Confirm hydraulic hoses are in good condition.
 - Do not continue to supply power to hydraulic winch after the auger has reached full up position.
 - Do not disconnect hydraulic quick couplers when lines are pressurized.
 - Make sure lift cable is seated in cable pulley.
 - Always keep a minimum of 3 cable wraps on the cable drum.

2.11. Positioning the Auger

- ⚠ WARNING**
- Transport and place equipment on reasonably level ground when raising, lowering, positioning, or operating.
 - Move the auger into position slowly. Do not unhitch and attempt to move by hand.
 - Chock wheels and anchor intake end after placement.

2.12. Towing the Auger

The auger is not intended for transport on public roads. If it requires transport on a public roadway, the following steps should be taken:

- ⚠ WARNING**
- Check with local authorities regarding transport on public roads. Obey all applicable laws and regulations.
 - Always travel at a safe speed, never exceeding 20 mph (32 km/h).
 - Reduce speed on rough surfaces.
 - Do not transport on slopes greater than 20°.
 - Use caution when turning corners or meeting traffic.
 - Make sure the SMV (slow moving vehicle) emblem and all the lights and reflectors that are required by local authorities are in place, are clean, and can be seen by all over-taking and oncoming traffic.
 - Always use hazard-warning flashers on tractor/towing vehicle when transporting unless prohibited by law.
 - Do not allow riders on the auger or towing vehicle during transport.
 - Attach to towing vehicle with an appropriate pin and retainer. Always attach safety chains.
 - Place the auger in the transport position before moving on roads.

2.13. Drives and Lockout Safety

Inspect the power source(s) before using and know how to shut down in an emergency. Whenever you service or adjust your equipment, make sure you shut down the power source and unplug or remove the key (as applicable) to prevent inadvertent start-up and hazardous energy release. Know the procedure(s) that applies to your equipment from the following power source(s). Ensure that all personnel are clear before turning on power to equipment.



2.13.1 PTO Driveline Safety

⚠ WARNING Drive

- Keep body, hair, and clothing away from rotating PTO driveline.
- Make certain the driveline shields telescope and rotate freely on driveline before attaching.
- Make certain the driveline is securely attached at both ends.
- Do not operate auger unless all driveline, tractor, and equipment shields are in place and in good working order.
- Do not exceed the specified operating speed.
- Keep universal joint angles small and equal. Do not exceed maximum recommended length for PTO driveline.
- Engage tractor park brake and/or chock wheels.

Lockout

- Position all controls in neutral, shut off tractor's engine, and remove key from tractor.
- If removing key is impossible, remove PTO driveline from tractor.



2.13.2 Hydraulic Power Safety

WARNING Power Source

- Refer to the rules and regulations applicable to the power source operating your hydraulic drive.
- Do not connect or disconnect hydraulic lines while system is under pressure.
- Keep all hydraulic lines away from moving parts and pinch points.
- Escaping hydraulic fluid under pressure will cause serious injury if it penetrates the skin surface (serious infection or toxic reaction can develop). See a doctor immediately if injured.
- Use metal or wood as a backstop when searching for hydraulic leaks and wear proper hand and eye protection.
- Check all hydraulic components are tight and in good condition. Replace any worn, cut, abraded, flattened, or crimped hoses.
- Clean the connections before connecting to equipment.
- Do not attempt any makeshift repairs to the hydraulic fittings or hoses with tape, clamps, or adhesive. The hydraulic system operates under extremely high pressure; such repairs will fail suddenly and create a hazardous and unsafe condition.

Lockout

- Always place all hydraulic controls in neutral and relieve system pressure before disconnecting or working on hydraulic system.



2.14. Tire Safety



WARNING

Failure to follow proper procedures when mounting a tire on a wheel or rim can produce an explosion that may result in serious injury or death.



- DO NOT attempt to mount a tire unless you have the proper equipment and experience to do the job.
- Have a qualified tire dealer or repair service perform required tire maintenance.
- When replacing worn tires, make sure they meet the original tire specifications. Never undersize the replacement tire.
- DO NOT weld to the tire rim with the tire mounted on the rim. This action may cause an explosion which could result in serious injury or death.
- Inflate tires to the manufacturer's recommended pressure.
- Tires should not be operated at speeds higher than their rated speed.
- Keep wheel lug nuts tightened to manufacturer's recommendations.
- Never reinflate a tire that has been run flat or seriously under-inflated without removing the tire from the wheel. Have the tire and wheel closely inspected for damage before remounting.

2.15. Personal Protective Equipment

The following Personal Protective Equipment (PPE) should be worn when operating or maintaining the equipment.

- **Safety Glasses**



Wear safety glasses at all times to protect eyes from debris.

- **Steel-Toe Boots**



Wear steel-toe boots to protect feet from falling debris.

- **Coveralls**



Wear coveralls to protect skin.

- **Work Gloves**



Wear work gloves to protect your hands from sharp and rough edges.

- **Hard Hat**



Wear a hard hat to help protect your head.

- **Hearing Protection**



Wear ear protection to prevent hearing damage.

- **Dust Mask**



Wear a dust mask to prevent breathing potentially harmful dust.

2.16. Safety Equipment

The following safety equipment should be kept on site.

- **Fire Extinguisher**



Provide a fire extinguisher for use in case of an accident. Store in a highly visible and accessible place.

- **First-Aid Kit**



Have a properly-stocked first-aid kit available for use should the need arise, and know how to use it.

2.17. Safety Decals

- Keep safety decals clean and legible at all times.
- Replace safety decals that are missing or have become illegible. See decal location figures that follow.
- Replaced parts must display the same decal(s) as the original part.
- Replacement safety decals are available **free of charge** from your distributor, dealer, or factory as applicable.

2.17.1 Decal Installation/Replacement

1. Decal area must be clean and dry, with a temperature above 50°F (10°C).
2. Decide on the exact position before you remove the backing paper.
3. Align the decal over the specified area and carefully press the small portion with the exposed sticky backing in place.
4. Slowly peel back the remaining paper and carefully smooth the remaining portion of the decal in place.
5. Small air pockets can be pierced with a pin and smoothed out using the decal backing paper.

2.17.2 Safety Decal Locations and Details

Replicas of the safety decals that are attached to the auger and their messages are shown in the figure(s) that follow. Safe operation and use of the auger requires that you familiarize yourself with the various safety decals and the areas or particular functions that the decals apply to, as well as the safety precautions that must be taken to avoid serious injury, death, or damage.

Figure 2. Decal Locations

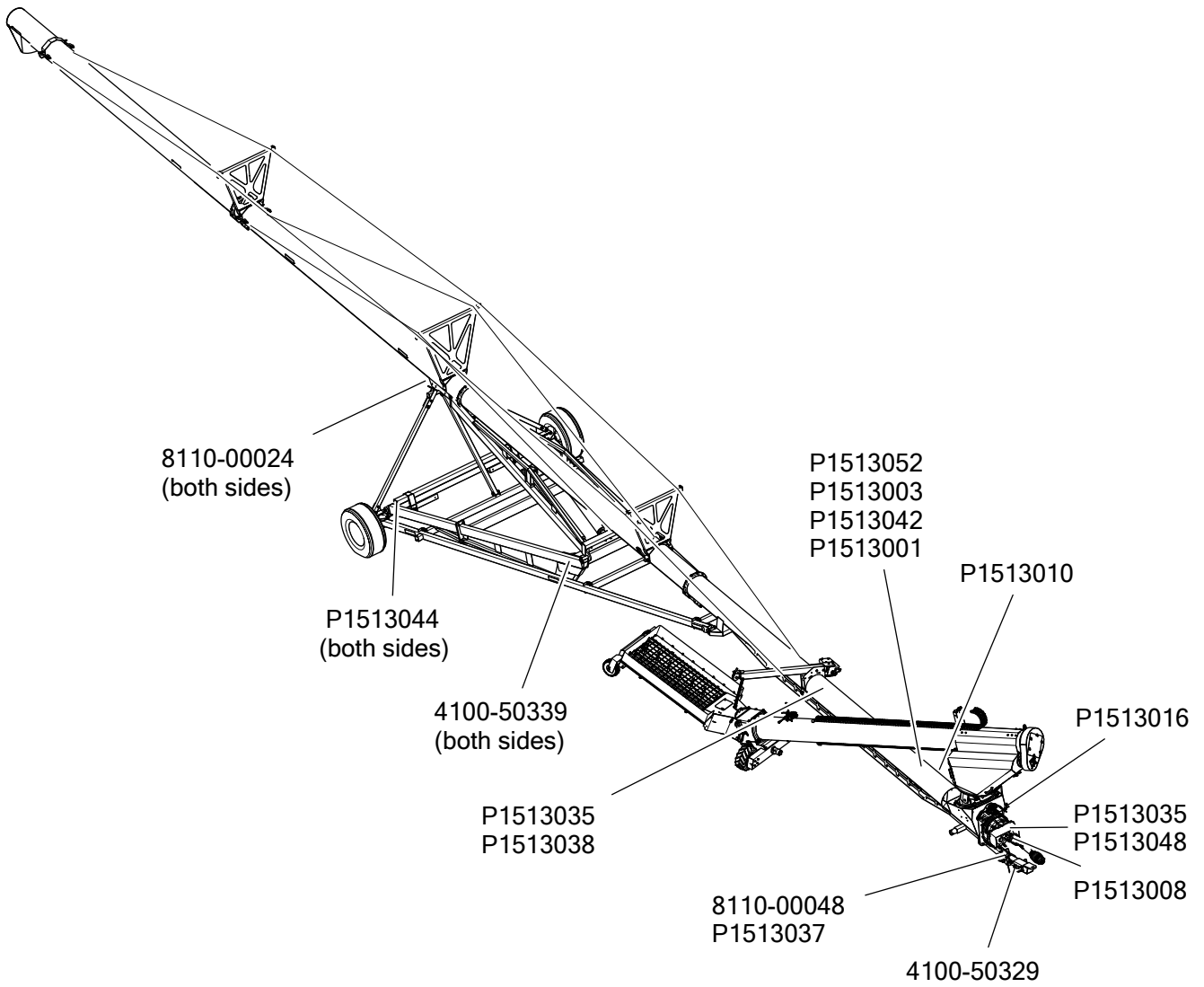

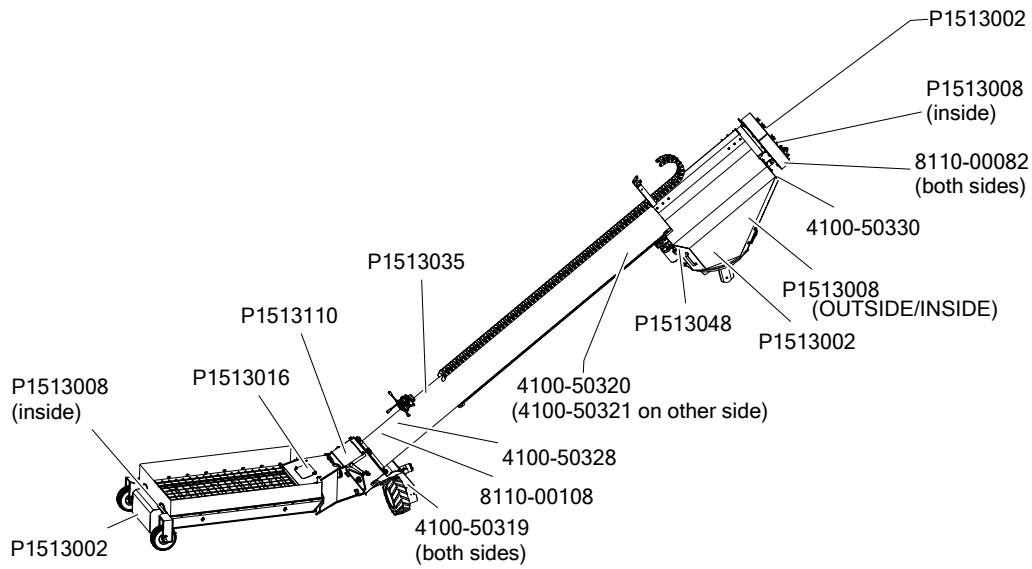



Table 1. Safety Decals

P1513016

⚠ DANGER



ROTATING FLIGHTING HAZARD

To prevent death or serious injury:

- KEEP AWAY from rotating auger flighting.
- DO NOT remove or modify auger flighting guards, doors, or covers. Keep in good working order. Have replaced if damaged.
- DO NOT operate the auger without all guards, doors, and covers in place.
- NEVER touch the auger flighting. Use a stick or other tool to remove an obstruction or clean out.
- Shut off and lock out power to adjust, service, or clean.

P1513002

⚠ WARNING



ENTANGLEMENT HAZARD

To prevent serious injury or death:

- Keep body, hair, and clothing away from rotating pulleys, belts, chains, and sprockets.
- Do not operate with any guard removed or modified. Keep guards in good working order.
- Shut off and lock out power source before inspecting or servicing machine.

P1513001

⚠ WARNING

To prevent serious injury or death:

- Read and understand the manual before assembling, operating, or maintaining the equipment.
- Only trained personnel may assemble, operate, or maintain the equipment.
- Children and untrained personnel must be kept outside of the work area.
- Do not modify the equipment. Keep in good working order.
- If the manual, guards, or decals are missing or damaged, contact factory or representative for free replacements.
- Lock out power before performing maintenance.
- To prevent equipment collapse or upending, support equipment tube while disassembling certain components.
- Follow grain storage structure manufacturer's warnings when loading and unloading.
- Electric motors must be grounded. Disconnect power before resetting overloads.

P1513035

WARNING	
HIGH PRESSURE FLUID HAZARD	
<p>Hydraulic fluid can cause serious injury if it penetrates the skin. If it does, see a doctor immediately.</p> <ul style="list-style-type: none"> • Relieve system pressure before repairing, adjusting or disconnecting. • Wear proper hand and eye protection when searching for leaks. Use wood or cardboard instead of hands. 	

8110-00108

CAUTION
<ol style="list-style-type: none"> 1. SHUT OFF PTO when retracting or extending swing to or from its fully retracted position. 2. Engaging spline shaft with PTO running will damage the machine. 3. Make certain everyone is clear of the equipment before applying power or moving the machine.

8110-00082

WARNING	
	<p>Moving Parts will cause severe injury.</p> <p>KEEP AWAY</p>
	<p>ROTATING SHAFT</p> <p>Keep hair and loose clothing away</p>

P1513048

DANGER	
ROTATING PTO DRIVELINE	
<p>To prevent serious injury or death:</p> <ul style="list-style-type: none"> • Keep body, hair, and clothing away from rotating PTO driveline. • Do not operate equipment unless all driveline, tractor, and equipment shields are in place and in good working order. • Make certain the driveline shields turn freely on driveline. • Make certain the driveline is securely attached at both ends. • Do not exceed specified operating speed (see operator's manual). • Keep u-joint angles small and equal. Do not exceed maximum recommended length for PTO driveline. 	

P1513003

DANGER	
ELECTROCUTION HAZARD	
<p>To prevent death or serious injury:</p> <ul style="list-style-type: none"> • When operating or moving, keep equipment away from overhead power lines and devices. • Fully lower equipment before moving. <p>This equipment is not insulated.</p> <p>Electrocution can occur without direct contact.</p>	

8110-00048

NOTICE
NOTICE
<p>Disconnect PTO driveline from tractor before moving equipment.</p> <p>If attached, driveline will bottom out, severely damaging the CV u-joint and lower flight shaft.</p> <p>See manual for maintenance.</p>

P1513037

WARNING	
TRANSPORT HAZARD	
<p>To prevent serious injury or death:</p> <ul style="list-style-type: none"> • Securely attach equipment to vehicle with correct pin and safety chains. • Use a tow vehicle to move equipment. 	

P1513052

NOTICE
<p>To prevent damage, wheels must be free to move when raising or lowering equipment.</p> <p>When equipment is positioned, chock all wheels.</p>

P1513008

WARNING	
	<p>MISSING GUARD HAZARD</p> <p>To prevent serious injury or death, shut off power and reattach guard before operating machine.</p>

P1513110

DANGER	
ROTATING FLIGHTING HAZARD	
<p>To prevent death or serious injury:</p> <ul style="list-style-type: none"> • KEEP AWAY from rotating auger flighting. • Shut off and lock out power before removing cover or servicing. 	

P1513042

WARNING	
UPENDING HAZARD	
<p>To prevent death or serious injury:</p> <ul style="list-style-type: none"> • Anchor intake end and/or support discharge end to prevent upending. • Intake end must always have downward weight. Do not release until attached to tow bar or resting on ground. • Do not raise intake end above tow bar height. • Empty tube and fully lower before moving. 	

P1513035

WARNING	
HIGH PRESSURE FLUID HAZARD	
<p>Hydraulic fluid can cause serious injury if it penetrates the skin. If it does, see a doctor immediately.</p> <ul style="list-style-type: none"> • Relieve system pressure before repairing, adjusting or disconnecting. • Wear proper hand and eye protection when searching for leaks. Use wood or cardboard instead of hands. 	

P1513038

WARNING

To prevent death or serious injury:

- Keep away from rotating cable drum and winch cable.
- Inspect lift cable periodically; replace if damaged.
- Inspect cable clamps periodically; tighten if necessary.

P1513010

CAUTION

To prevent personal injury or damage to equipment, close valve in lift cylinder hydraulic line after raising equipment into position.

4100-50320

NOTICE

DO NOT operate the PTO when retracted past this point.

Failure to follow could result in equipment damage.

P1513044

WARNING

ROLLOVER / TRANSPORT HAZARD

To prevent serious injury or death:

- Fully extend axles before raising load.
- Retract axles before transporting.

8110-00024

WARNING

4100-50330

IMPORTANT

Lubricate drive splines every 4 hours of use.

4100-50319

CAUTION

MOVING EQUIPMENT

This machine moves in all directions under operator control.

4100-50321

NOTICE

DO NOT operate the PTO when retracted past this point.

Failure to follow could result in equipment damage.

4100-50329

OPERATION

HITCH PIVOT PIN

TRANSPORT

3. Features

Read this section to familiarize yourself with the basic component names and functions of the auger.

Figure 3. Auger Features

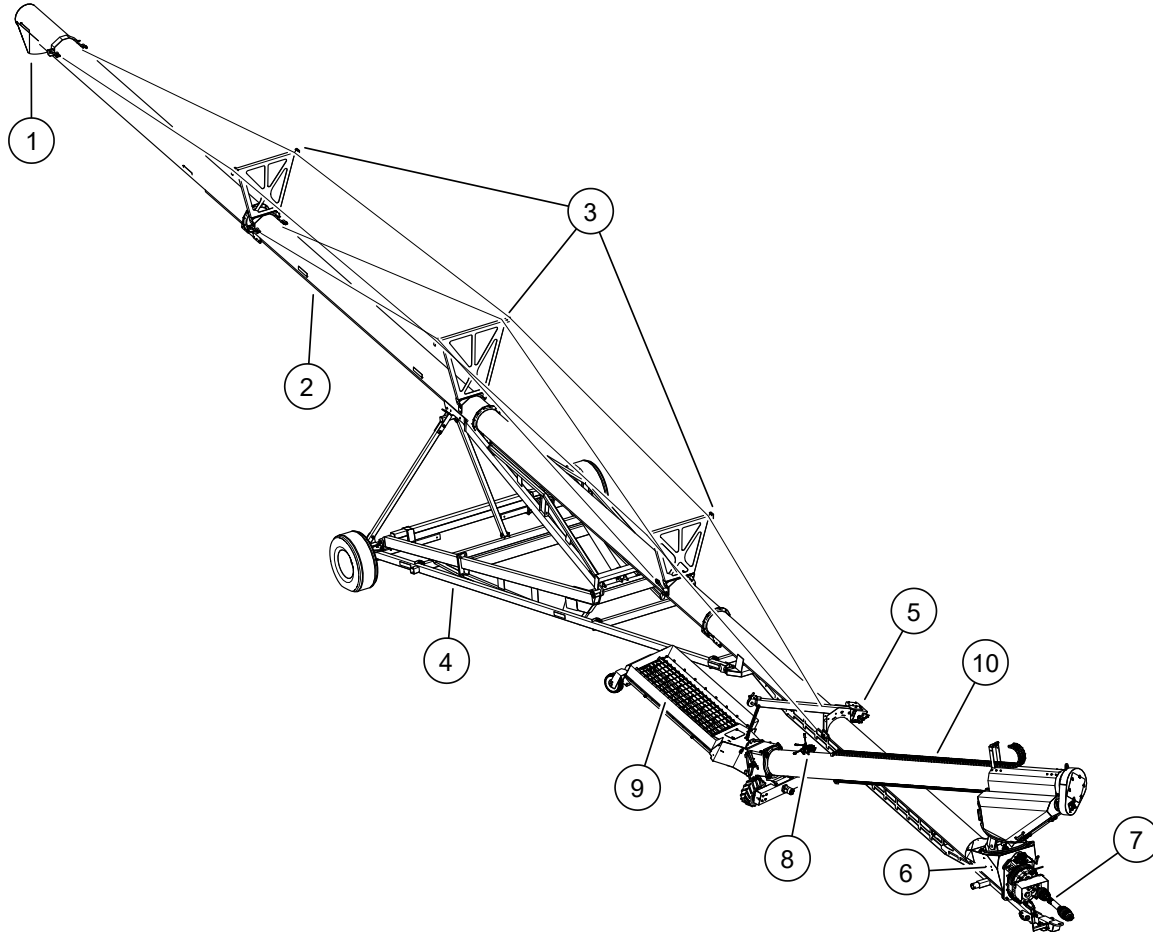

Table 2. Auger Features

Item	Description	Item	Description
1	Spout	6	Boot
2	Tube	7	PTO
3	Trussing	8	Swing-Away Controls
4	Frame	9	Hopper
5	Hydraulic Winch	10	Telescoping Swing-Away (Swing-Away)

4. Transport



Before continuing, ensure you have completely read and understood this manual's Safety section, in addition to the safety information in the section(s) below.

4.1. Transport Safety

WARNING

- Check with local authorities regarding transport on public roads. Obey all applicable laws and regulations.
- Always travel at a safe speed, never exceeding 20 mph (32 km/h). Reduce speed on rough surfaces. Use caution when turning corners or meeting traffic.
- Yield to other drivers and allow faster traffic to pass.
- Make sure the SMV (slow moving vehicle) emblem and all the lights and reflectors that are required by local authorities are in place, are clean, and can be seen by all over-taking and oncoming traffic. Always use hazard-warning flashers on tractor/towing vehicle when transporting unless prohibited by law.
- Do not transport during times of limited visibility such as fog, snow, or heavy rain. Take extra precautions at night and at dusk.
- Keep others away from the transport vehicle and auger.
- Do not allow riders on the auger or towing vehicle during transport.
- Stay away from overhead obstructions and power lines when operating and transporting. Electrocutation can occur without direct contact.
- Fully lower the auger before transporting, and only raise when next to storage facility.
- Attach to a proper towing vehicle with a pin and retainer. Always attach safety chain(s).
- Do not raise the intake end above drawbar, upending may occur.
- Empty auger of all grain or seed before transporting. Transporting a full auger will place excessive loads on the tube, frame, axle, hitch, and tow vehicle.
- Do not transport on slopes greater than 20°.
- Use caution when transporting the auger over rolling terrain. In severe dips, the intake end may contact the ground.
- Do not transport with an under-inflated tire(s).
- If the auger wheels are partially or fully buried in snow or grain, failure to clear area around the wheels before transporting may cause damage to the auger or result in serious injury.

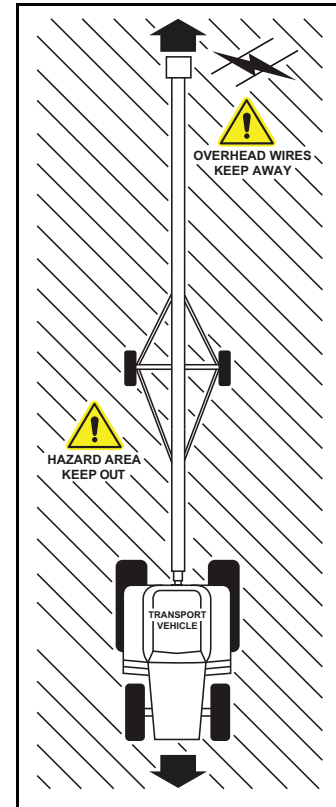

4.2. Transport Preparation

1. It is not recommended that the auger be transported faster than 20 mph (32 km/h). [Table 3](#) references the acceptable transport speed as per the ratio of tractor weight versus auger weight. See Specifications ([Section 9. – Specifications on page 56](#)) for auger weights.

⚠ WARNING A weight imbalance between the auger and the towing vehicle could result in a collision from reduced stability, handling, and braking ability.

2. Ensure the auger will clear any overhead obstructions or electrical wires prior to transporting. Refer to [Section 9. – Specifications on page 56](#) for the transport height of your auger.
3. Longer augers have a large turning radius. Allow ample room for turning as the discharge end may swing dramatically. Allow all oncoming traffic to pass before turning right or left.

⚠ WARNING A collision with an oncoming vehicle could occur if the auger discharge swings into the opposing lane.

Table 3. Speed versus Weight Ratio

Road Speed	Weight or fully equipped or loaded implement(s) relative to weight of towing machine
Up to 32 km/h (20 mph)	1 to 1, or less
Up to 16 km/h (10 mph)	2 to 1, or less
Do not tow if	More than 2 to 1

4.3. Swing Away Transport Preparation

1. Fully extend the swing away to reach the lift arm on the main auger.
2. Straighten the hopper using control (1) to avoid interference with the frame, see [Figure 4](#).
3. Attach the winch cable (B) to the hopper, lift into position, and secure the transport chain (A). Refer to [Figure 5 on page 23](#).

Figure 4. Control Handle

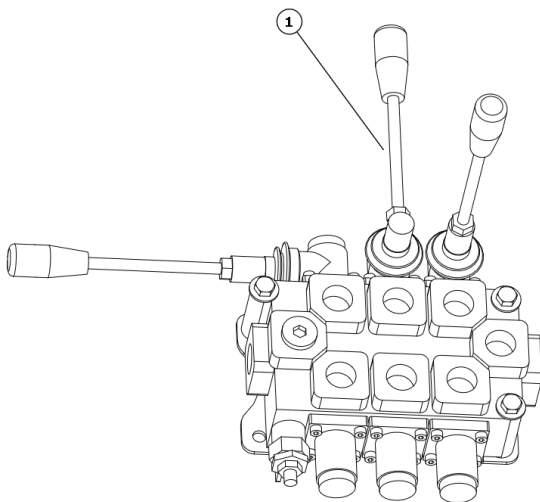
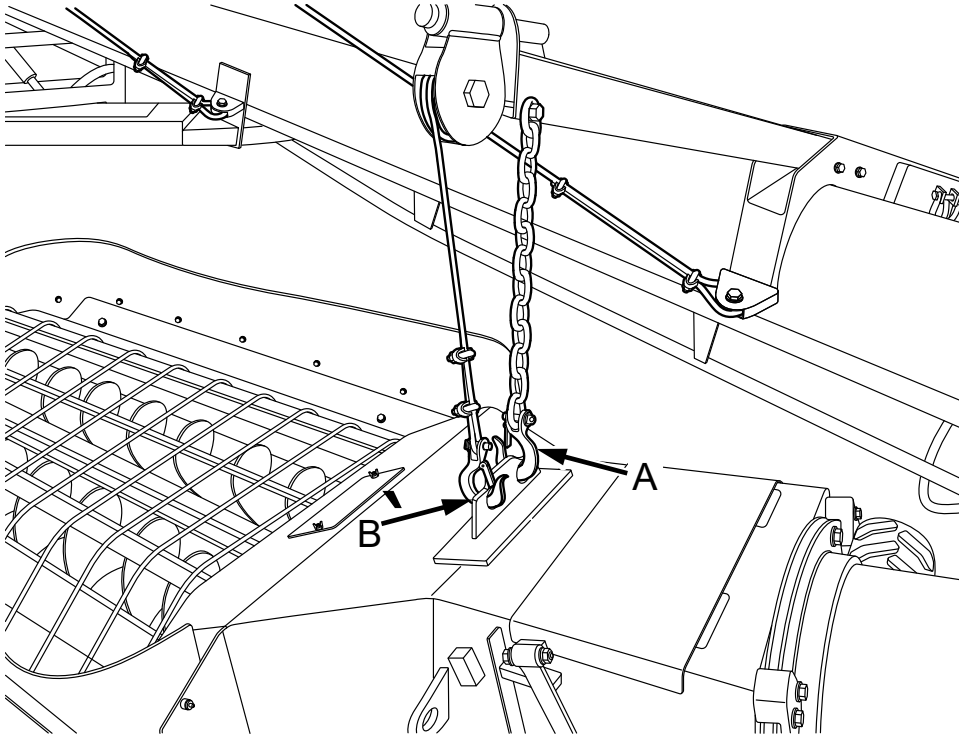

Figure 5. Transport Position and Chain Attach



4.4. Preparing the Auger for Towing

Follow all safety precautions when transporting the auger and use a proper towing vehicle.

1. Fully lower the auger.
2. Disconnect the PTO driveline and hydraulics (as applicable) from the tractor.
3. Fully retract the wheel axles (if applicable).
4. Place the hitch in transport position.
5. Connect the auger to the tow vehicle with a hitch pin. Use a hitch pin that will not allow the auger to separate from the towing vehicle.
6. Connect the safety chain securely, forming a cradle to prevent the auger from digging into the road surface (should a breakaway occur). Do not use the safety chain if one or more links or end fittings are stretched, broken, damaged, or deformed.

Note

The safety chain should have a load rating at least as high as the auger weight.

7. Move the jack into storage position.
8. Place the intake hopper into transport position. Refer to [Section 4.3 – Swing Away Transport Preparation on page 22](#).
9. Place the swivel jack (on side of hitch) in transport position and lock.
10. Use caution when transporting the auger over rolling terrain. In severe dips, the intake end may contact the ground. Refer to [Section 9. – Specifications on page 56](#) for auger weight and hitch pin information.

Figure 6. Hitch Positions

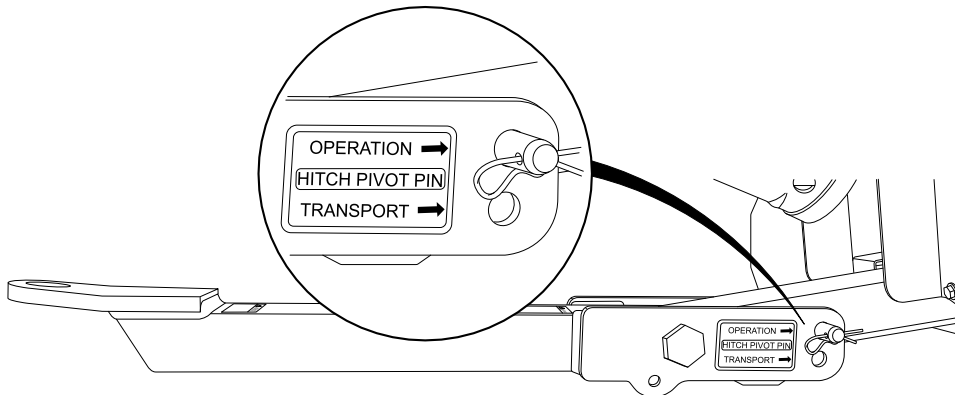

5. Placement



Before continuing, ensure you have completely read and understood this manual's Safety section, in addition to the safety information in the section(s) below.

5.1. Placement Safety

WARNING

- The auger is not insulated, keep away from overhead power lines. Electrocutation can occur without direct contact.
- Anchor intake end before using.
- Place the auger on reasonably level ground before operating. The auger could topple if ground is too uneven.
- Chock the auger wheels after placement.
- Empty the auger before raising, lowering, or positioning.
- Check that wheels are free to move before raising or lowering the auger.
- Never attempt to increase height of the auger by positioning wheels on lumber, blocks, or by any other means.
- Do not permit anyone to stand beneath the auger when raising or lowering.
- Move the auger into position slowly. Do not unhitch and attempt to move by hand.
- Do not leave auger in raised position when not in use.

5.2. Positioning the Auger

Filling Bins

The auger is designed to be transported and operated without unhitching unit from tractor.

1. Disconnect the PTO driveline from the tractor and secure it in the transport saddle.

NOTICE

Failure to disconnect from the tractor will damage the PTO driveline.

2. Ensure that the tractor and auger are securely hitched together.

Important

Use a type of hitch pin (see Auger / Tractor Hookup section) that will not allow the auger to separate from towing vehicle.

3. Disconnect the safety chain from the intake hopper.
4. Before connecting the hydraulics, ensure that the quick-connect coupler on the auger and tractor is clean and free of dirt by wiping with a cloth.



WARNING

Dirt in the hydraulic system can damage the cylinder o-rings, causing leakage and the possible failure of the system and personal injury.

5. Connect hydraulic hoses, ensure connections are tight. Check for leaks, binding, flattening, kinks, or wear.
6. Fully extend wheel axles, see Extendable Axle Positioning.
7. Adjust the hitch to the operating position.

8. Move the jack into storage position.
9. Move the auger into working position slowly. Do not unhitch and attempt to move the auger by hand.
10. Back the auger up to the storage facility while it is in its lowered configuration.
11. Raise the auger so it clears the storage facility. See **Raising and Lowering**.
12. Slowly back the auger up until the outlet is over the opening in the storage facility.
13. Slowly lower the auger to the bin.
14. Set the park brake on the tractor before dismounting, or chock its wheels.
15. Once the auger is in position, chock its wheels.
16. Lower the intake hopper to the ground, see Raising and Lowering the Intake Hopper.
17. See Operation for correct operating procedures.

Figure 7. Hitch Positions

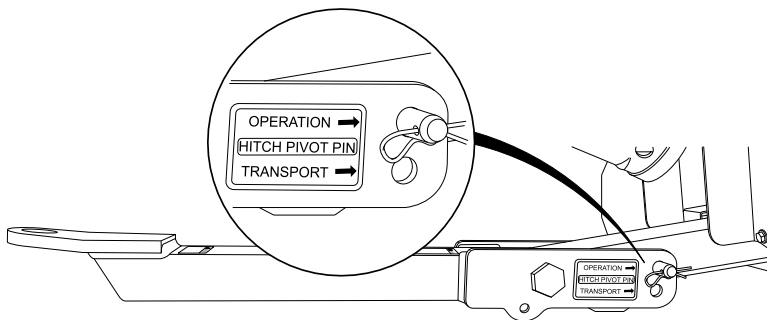
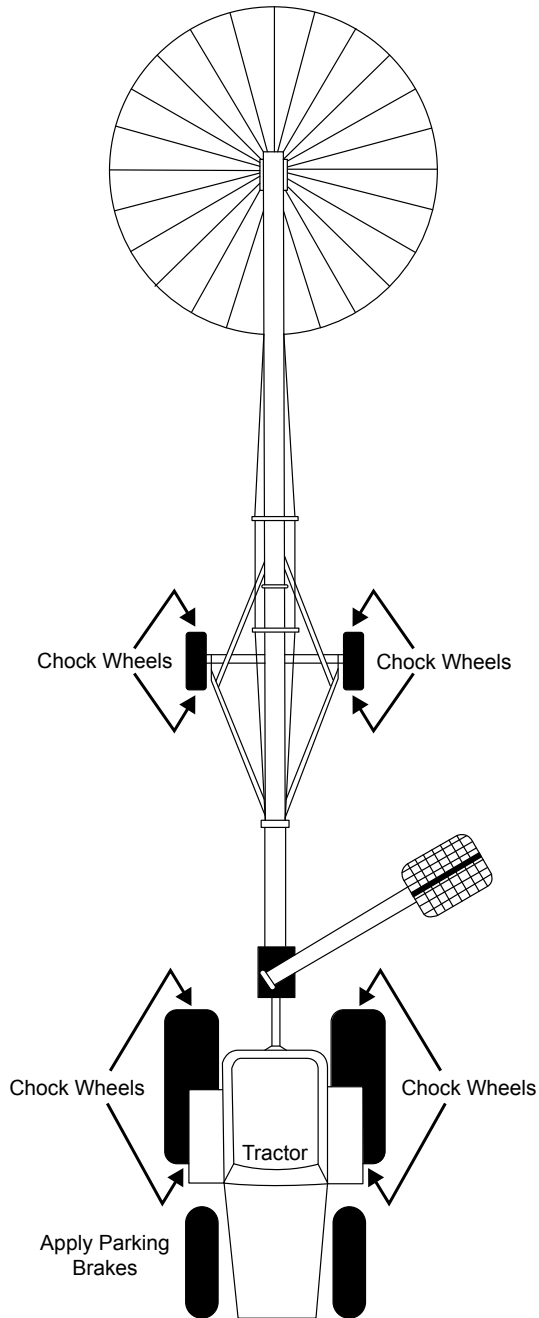

Figure 8. Auger Placement (Direct PTO Drive)

5.2.1 Raising and Lowering

The intake hopper must be off the ground when raising and lowering the auger.

Before using the hydraulic lift cylinder:

- Check that the hydraulic hoses are free from leaks, binding, flattening, kinks, or wear.

Raising

1. Before connecting the hydraulic hose, wipe the hose coupler clean.

NOTICE

Dirt in the hydraulic system can damage the cylinder o-rings and can cause leakage and failure of the system.

2. Connect the hydraulic hoses, ensure the connections are tight. Visually check for leaks, binding, flattening, kinks, or wear.
3. Open the ball valve on the hose connected to the cylinder.
4. Start tractor and idle at low rpm.
5. Engage hydraulic lever to power the cylinder.
6. Increase tractor rpm until desired rate of lift is reached.
7. Raise the auger to the desired height.
8. Close the hydraulic ball valve when the auger is fully raised.

NOTICE

Failure to close the ball valve may cause the frame to creep lower, potentially damaging the auger.

Lowering:

1. Reconnect the hydraulic hose coupler to tractor, if disconnected. Keep the tractor running while lowering the auger should the need arise to re-lift it.

NOTICE

Some augers are equipped with dual acting hydraulic cylinders, for these units the tractor must be running to pump oil to the upper chamber of the hydraulic cylinder(s) to prevent overfilling of the tractor reservoir.

2. Open the ball valve.
3. Open the tractor valve, feathering the control to prevent too rapid a descent.

Note

Once the valves are opened, the auger tube lowers by gravity. As the tube nears the full down position, the rate of descent will increase. Do not operate with the tractor valve fully open.

4. Turn off the tractor, and lock out the tractor power source.
5. Before disconnecting hydraulic couplers, relieve the hydraulic pressure.

WARNING

Disconnecting a hydraulic hose under pressure can result in serious injury.

5.3. Extendable Axle Positioning



When equipped with extendable axles:

Important

Do not raise the auger unless the axles are in the extended position. Do not transport the auger unless the axles are in the retracted position.

WARNING

Rollover can occur if axles are not extended before raising the auger.

1. Ensure the auger is on level ground before attempting to extend or retract the axles. **The auger must be attached to tractor at all times.**

2. Using the jack supplied, insert it into one of the jack stubs located on one end of the axle. Jack must be secured to jack stub using pin (attached to jack).
3. Raise one side at a time. Raise until the tire clears the ground.
4. Remove the axle pin from the axle and position the axle as desired until the holes line up. Reinsert the axle pin and secure with hairpin. Lower the jack.
5. Repeat the process on the opposite side of the axle.

Figure 9. Typical Extendable Axle

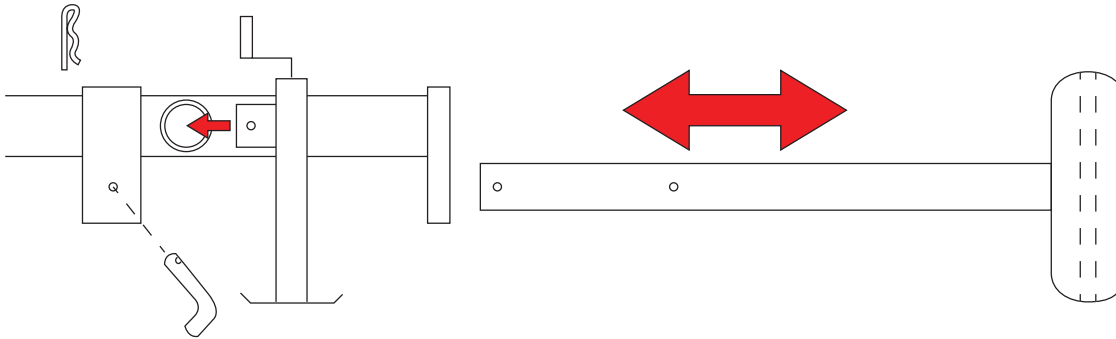

5.4. Auger-to-Tractor Hookup

The auger must be correctly connected to the tractor for all operations, including transport, raising, placement, and augering grain.

When attaching the auger to your tractor, the only suitable hitch is a clevis-type hitch that is appropriately sized and rated for towing the auger. Always use a proper hitch pin that is rated for the load and application, and ensure that the hitch pin is secured with a suitable hairpin.

Important

Do not use a tractor that is equipped with a Quick Hitch. Remove the Quick Hitch before attaching. A Quick Hitch will hit the auger when making turns or it can contact the PTO driveline if lowered during operation.

Figure 10. Hitching the Auger to a Tractor

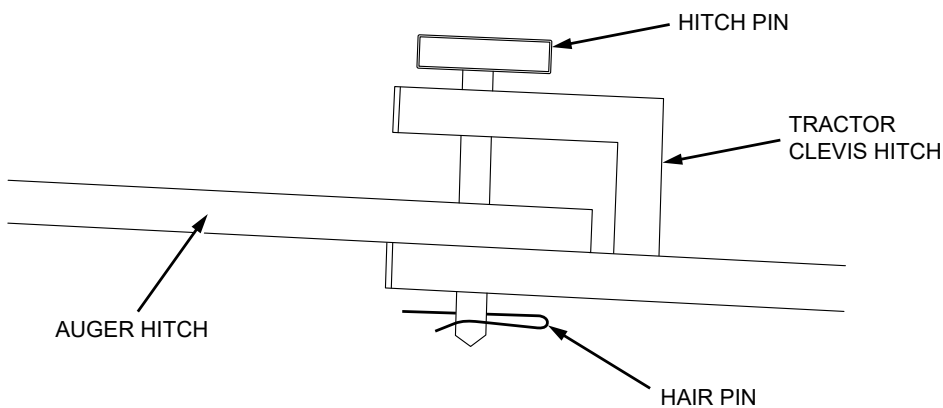

Measurements Between Drawbar and Driveline

Since the auger and tractor become an integral unit during transport, placement, and operation, the configuration and measurements between the tractor drawbar and the tractor PTO driveline are very important.

The tractor drawbar dimension must be 14 inches between the end of the shaft and drawbar pin hole center. This will provide clearance for turning and allow telescoping of the shaft when the auger is raised. Consult your tractor manual for the drawbar adjustment procedure.

Use a tractor PTO shaft that is 1000 RPM, 21 spline, 1-3/8" diameter.

Important

Do not use shaft adaptors on the tractor shaft.

Use the jack on the hitch to raise or lower the auger as required to match the drawbar.

Figure 11. Measurements Between Drawbar and PTO Driveline

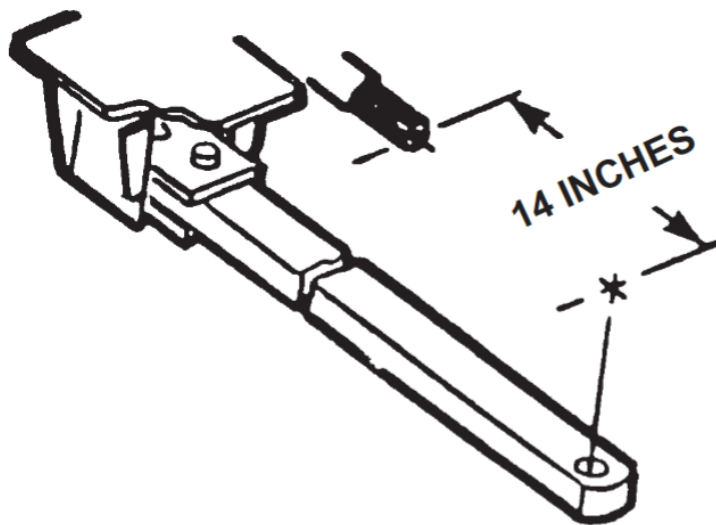

5.5. Raising and Lowering the Intake Hopper

1. Attach the winch cable hook (B) to the appropriate hopper lifting point.
2. Fully raise the hopper.
3. Secure the hopper with the transport chain and hook (A).

NOTICE

Do not operate auger with intake hopper in transport position. This will damage the u-joint.

4. Ensure swing-away is empty before raising or lowering.
5. Do not permit anyone to stand near the swing-away when raising or lowering.

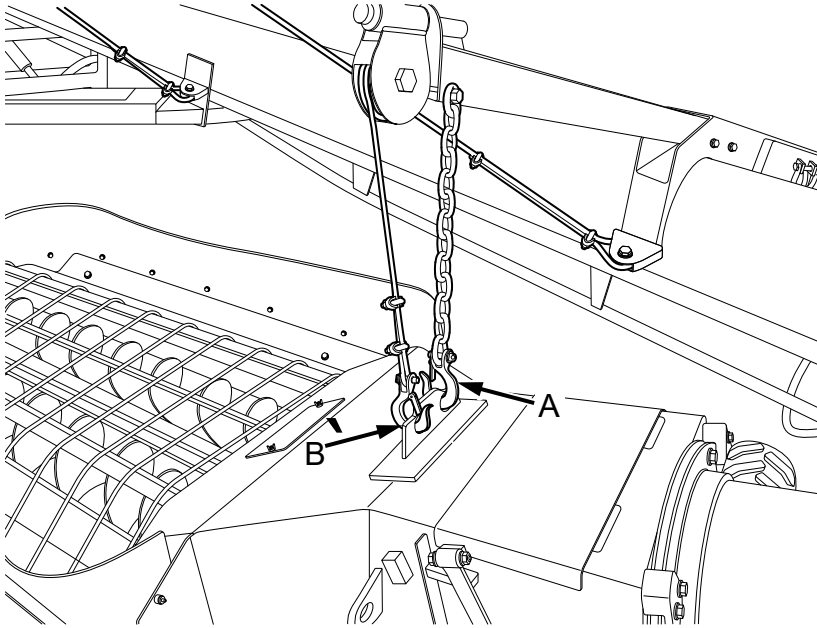
Figure 12. Raised Position

5.5.1 Swing-Away Hydraulic Winch Operation

1. Before connecting hose, wipe coupler clean.

NOTICE

Dirt in the hydraulic system can damage the winch motor and can cause failure of the system.

2. Connect hydraulic hoses, ensure connections are tight. Visually check for leaks, binding, flattening, kinks, or wear.
3. Check that cable anchor on winch drum is tight, cable clamps are secure, lift cable is seated in cable pulley, and inspect cable before operating. If damaged, replace immediately.
4. Always keep a minimum of 3 cable wraps on the drum with the swing-away hopper fully lowered.
5. Start tractor and idle at low rpm. Engage hydraulic lever to power winch. Test the direction of rotation of winch to ensure drum is moving in the direction required. Increase tractor rpm until desired rate of lift or descent is reached.
6. Do not touch, grab, or guide cable while equipment is being raised or lowered.

CAUTION

Do not continue to supply power to winch when swing-away is fully up. Damage to equipment and/or personal injury could result.

5.6. Grain Hopper Positioning

The low-profile grain hopper is designed to be rolled into position to receive grain for transfer through the boot to the auger discharge spout. Ground clearance can be adjusted by raising or lowering the position of the hopper wheel axles.

The grain hopper must be lifted and secured for transport using the hopper lift arm, hydraulic winch, and transport chain and hook. The hopper lift arm can be reconfigured for lifting on either side of the auger.

5.6.1 Hydraulic Power Swing Operation

1. Adjust the tractor's output flow using the flow control lever to achieve 4-5 gpm. This will ensure a controlled speed.
2. Put the lever that controls your tractor hydraulics in the detent position where the hydraulics stay engaged all the time.
3. To activate the Power Swing:
 - a. Push the center control lever (2) on the Power Swing valve control assembly to raise the hopper.
 - b. Use the left-side control lever (1) to swing the hopper left and right.
 - c. Use the right-side control (3) lever to extend or retract the hopper.
 - d. Once finished moving the hopper to the desired position, use the right side control lever to lower the hopper.

Figure 13. Control Valve Lever Functions

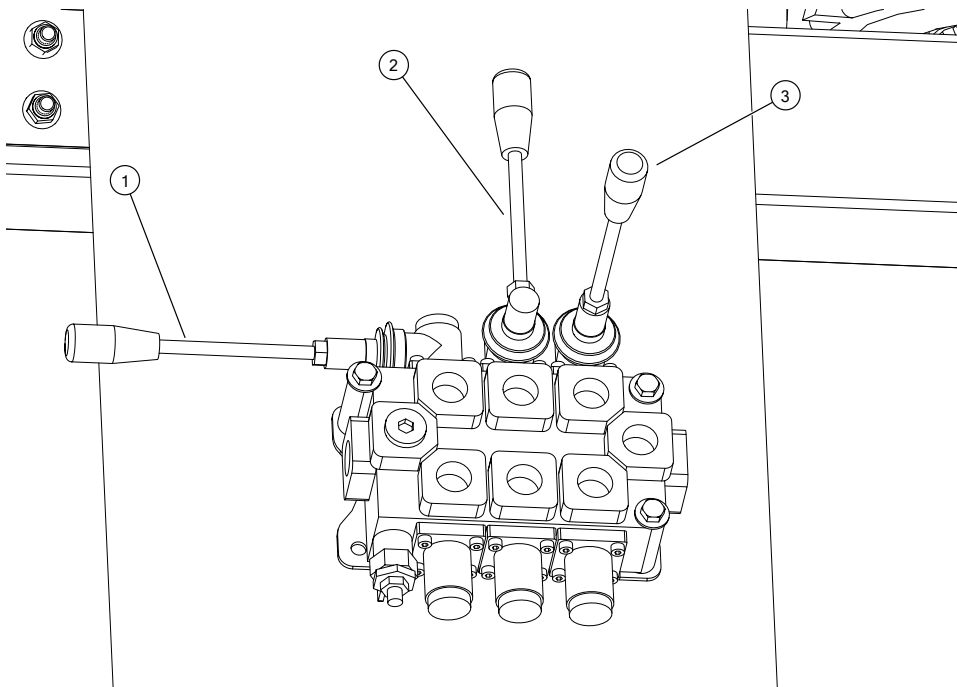

5.6.2 Telescoping Swing-Away Operation

The telescoping swing-away has three functions: swing, tip-up and extend. These are controlled with a three handle hydraulic valve located on the swing auger tube above the hopper. The decal on the side of the tube indicates the maximum allowable retraction while the PTO is engaged.

NOTICE

Turn down the tractor hydraulic flow to prevent damage to the swing-away and to prevent excessive heat buildup.

1. Lower the swing-away from the transport position, tilt the end of the hopper up so that the weight is on the power-swing tires and place it in the unloading position, roughly perpendicular to the auger.
2. Lower the hopper fully to shift the weight from the powerswing tires onto the hopper tires.
3. Retract the telescoping swing-away all the way.

4. Position the grain truck roughly two feet from the end of the swing-away, with it centered between the truck hoppers.
5. Extend the telescoping swing-away fully.
6. Tilt/raise the swing-away up to shift the weight onto the power-swing tires and position it under the desired truck hopper.
7. Lower/tilt the swing-away to be flush with the ground when unloading.
8. Engage the tractor PTO, unload the grain truck until flow stops and close the truck hopper.
9. Repeat the procedure to unload the remaining truck hoppers.
10. Disengage the PTO drive.
11. Retract the hopper fully to move the grain truck out of the way.

Note

The swing-away position may be moved between truck hoppers with the PTO running as long as the spline shaft at the top does not become disengaged. On the 13" swing-away there is 24" of free movement back from full extension. The end of free working travel is indicated by the auger Decal starting to appear from under the collector cover.

NOTICE

The spline can become damaged if engaged/disengaged while the PTO is operating. Keep movement limited between the two truck hoppers.

Figure 14. Telescoping Swing Away Operating Decal

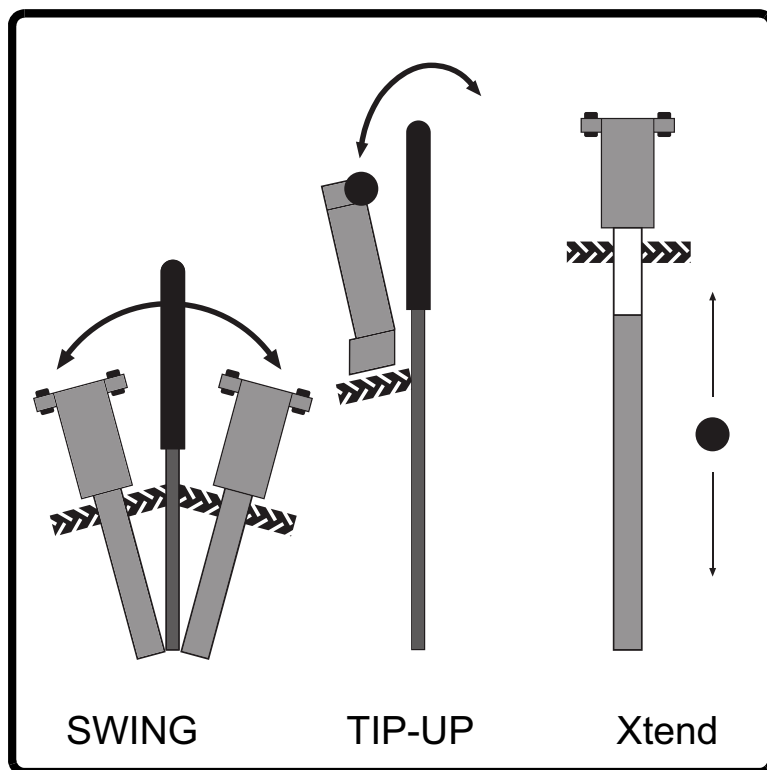

6. Operation



Before continuing, ensure you have completely read and understood this manual's Safety section, in addition to the safety information in the section(s) below.

6.1. Operation Safety



WARNING

- Keep away from rotating and moving parts, including the auger/mixer flighting, drive components, shafts, and bearings.
- Do not enter the grain bin or truck while the auger is operating.
- Always operate with guards, covers, and shields in place.
- Have another trained person nearby who can shut down the equipment in case of accident.
- Keep the work area clear of bystanders.
- Keep the work area clean and free of debris.
- Ensure maintenance has been performed and is up to date.



Refer to your bin operation manual for specific operating and safety information for your bin.

6.2. Start-up and Break-in

Check the following during the first hours of operation.

1. Check that the auger intake and discharge areas are free of obstructions.

NOTICE

Foreign objects can damage the auger. Remove any obstructions from the intake and discharge areas before operating the auger.

2. Visually inspect the auger, see Visual Inspection in Maintenance Section.
3. Check tightness of all bolts/nuts, fasteners, and hardware (re-torque if necessary).
4. Ensure adequate power is supplied to operate the auger, see [Section 9. – Specifications on page 56](#).
5. Start the tractor and idle at low rpm. Slowly engage the PTO drive. Refer to PTO Drive Operation.
6. Gradually begin feeding grain into the hopper, bringing the tractor PTO drive to roughly half speed. Do not overfeed the hopper on initial loads; keep the feed of grain at about half capacity.
7. Be aware of unusual sounds. If any are heard, determine the source and stop the auger. Lock out and correct the problem before resuming work. If you are unsure of the problem or procedure, contact your local dealer.
8. Proceed to unload at the specified full PTO speed. Do not exceed 1000 RPM full PTO speed.
9. Do not run the auger for long periods of time without material because it increases wear. Try to run only when moving material.
10. Stop the auger when it is empty of grain, lower fully and lockout power.

Important

After the initial start-up and inspection, the auger should be shut down and visually inspected (see Maintenance Section) after approximately ten hours of operation.

6.3. Operation - PTO Drive

1. Attach the PTO driveline securely to the tractor and confirm the connection to the auger shaft is secure.
2. Confirm the PTO driveline rotating shield and other shields/guards are in place and in good working order.
3. Align the tractor axis with the auger input shaft to minimize the angles of the universal joints on the PTO driveline.

Important

Check that the PTO does not exceed the maximum operating angle, refer to [Section 9. – Specifications on page 56](#).

4. Confirm that the auger-to-tractor PTO hookup distances are set as required.
5. Ensure the PTO drive on the tractor is in the off position before starting the tractor.
6. Start tractor engine at low idle, slowly engage the PTO with the tractor idling to prevent unneeded stress on the drive components and shear bolts.
7. If everything is operating normally, start running grain through the auger and increase the tractor PTO to the specified full speed to produce the required flow.
8. To shut down, reduce the speed to low idle and lock out the PTO.
9. Disconnect the PTO driveline from the tractor and secure it to the PTO transport saddle with the safety chain and keep it in transport saddle when transporting.

When raising or lowering the auger:

Disconnect the PTO driveline.

When starting under load:

If restarting the auger under load (tube is full), engage the PTO with the tractor idling.

NOTICE

Engaging the PTO at high engine speed under load will result in equipment damage.

Shear Bolts:

If a shear bolt in the PTO driveline fails, shut down and lock out the tractor to replace the shear bolt. Ensure that the shear point is through the shank of the bolt, not the threads. Refer to [Section 9. – Specifications on page 56](#) for shear bolt sizes.

Reverse Operation

Use reverse operation to clean out the auger. Do not unplug the auger using the reverser. Excessive back pressure will cause extensive damage to the auger and is not covered by warranty.

To operate the auger in reverse:

1. Shut down the tractor and remove the key.
2. Move the spline shaft from the operation port to the reverser port.
3. Start the tractor and operate the auger slowly in reverse for a short period of time. Do not exceed 100 RPM.

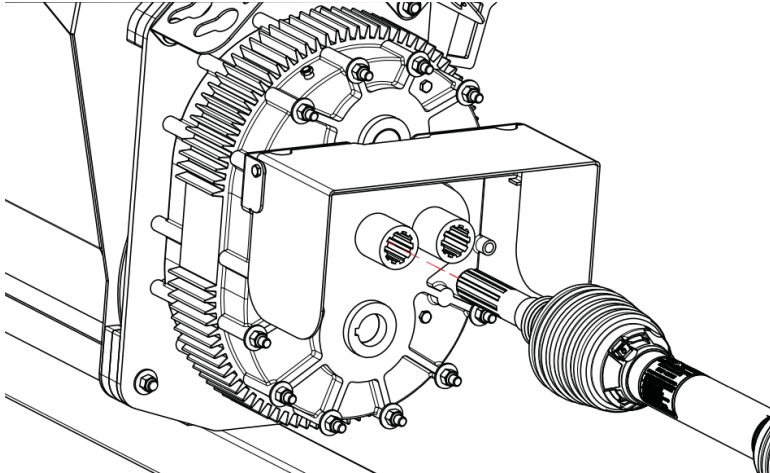
Figure 15. Reverse Position

6.4. Emergency Shutdown

In an emergency situation:

1. Stop or shut down the power source immediately and lock out all power.
2. Stop the flow of material (if applicable).
3. Ensure the machine components come to a stop before inspecting.
4. Correct the emergency situation before resuming work.

6.5. Restarting with a Full Tube

When the auger is shut down inadvertently or due to an emergency, the tube may still be filled with grain.

1. With the power source locked out, remove as much of the grain as possible from the tube and intake using a shop vacuum or other tool. Do not use your hands.

NOTICE

Starting under load may result in damage to the auger.

2. If guards or covers have been opened or removed, close or replace them before restarting the unit.
3. If the auger tube is full of grain, do not restart at full speed. Engage the drive at low power, gradually increasing until normal operating speed is reached.

Note

In extreme situations, the internal drive between the internal upper and lower gearbox can be disconnected to prevent more flow of grain into the main tube. Once the main auger tube has been cleared of material, the internal vertical driveline can be attached again to begin flow of material from the swing auger in to the main tube.

4. Once the auger has been started, you may resume normal operation.

6.6. Shutdown

When operation has been completed:

1. Once auger is clear of grain, lock out the power source.
2. Clean out any remaining grain from the auger with a vacuum or sweep out.
3. Clean the entire work area.
4. Remove anchors, supports, and chocks.
5. Disconnect the PTO driveline, and raise the intake hopper off the ground.
6. Move the auger away from the bin, and ensure that there is nothing under the auger that would make contact when the auger tube is lowered.
7. Lower the auger, refer to Raising and Lowering.
8. Lift the intake feed hopper fully into transport position, and secure it with the safety chain, refer to Raising and Lowering the Intake Hopper.

6.7. Operating the Auger with Fertilizer

If auger has been used to move fertilizer, it should be cleaned out to prevent corrosion. The easiest way to prevent corrosion is to run a load of grain through it after moving fertilizer or clean the machine as noted in the Maintenance section.

6.8. Storage

After the season's use, the auger should be thoroughly inspected and prepared for storage. Repair or replace any worn or damaged components and perform maintenance as described in the Maintenance Section to prevent any unnecessary downtime at the start of the next season.

To ensure a long, trouble-free life, this procedure should be followed when preparing the unit for storage.

1. Remove all residual material from the hopper and the tube.
2. Wash the auger thoroughly using a water hose or pressure washer to remove all dirt, mud, debris, or residue.
3. Inspect all moving or rotating parts to see if anything has become entangled in them. Remove any entangled material.
4. Touch up all paint nicks and scratches to prevent rusting.
5. Check tire pressure and inflate. For inflation pressure, refer to [Section 9. – Specifications on page 56](#).
6. Inspect the auger for cracks, tightness of fittings and fasteners, hydraulic hose cracks (if applicable). Have required repairs performed to replace worn or damaged components.
7. Store in an area that is dry, level, free of debris, and away from human activity. Store inside if possible.
8. Chock wheels.
9. Support intake on blocks to eliminate prolonged contact with the ground.
10. Clean and lightly lubricate the spline on the PTO driveline. Cover the PTO driveline with a plastic bag to protect it from the weather and place it in the transport saddle.
11. Lower the auger fully for storage.

12. Connect the winch cable and safety chain as shown to place the swing-away hopper in storage position. This position ensures there will be adequate drainage of any moisture.

Figure 16. Swing-Away Hopper Storage Position

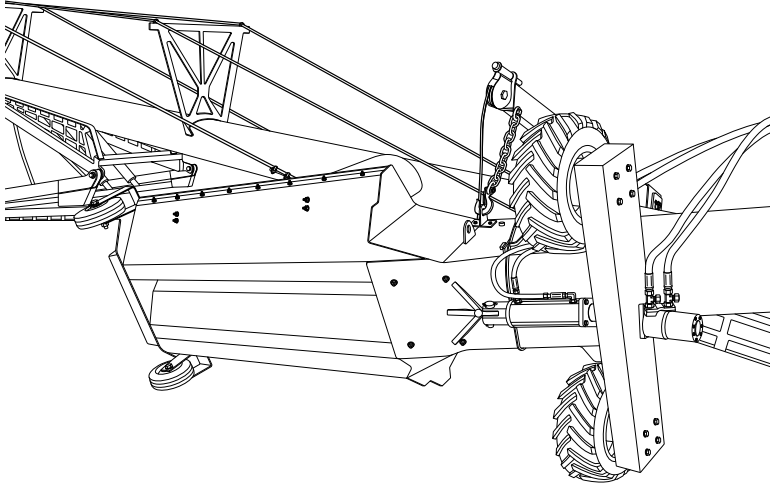

Power Swing

➡ When Equipped:

1. Raise wheels to full up position.
2. Clean out axle assembly and lubricate chains with a light coating of oil.
3. Inspect unit for damage and note any repairs required. Order replacement parts from your dealer.
4. Check tire pressure and inflate according to tire side-wall recommendations.

7. Maintenance

 Before continuing, ensure you have completely read and understood this manual’s Safety section, in addition to the safety information in the section(s) below.

7.1. Maintenance Safety

WARNING

- Keep components in good condition. Follow the maintenance procedures.
- Ensure the service area is clean, dry, and has sufficient lighting.
- Do not modify any components without written authorization from the manufacturer. Modification can be dangerous and result in serious injuries.
- Shut down and lock out power before maintaining equipment.
- After maintenance is complete, replace all guards, service doors, and/or covers.
- Use only genuine GrainMaxx replacement parts or equivalent. Use of unauthorized parts will void warranty. If in doubt, contact GrainMaxx or your local dealer.



Before attempting maintenance of any kind:

- Lower the auger fully.
- Chock wheels.
- Support tube if performing maintenance on the undercarriage assembly.
- Before applying pressure to a hydraulic system, make sure all components are tight and that hoses and couplings are in good condition.

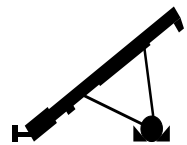

7.2. Maintenance Schedule

Proper maintenance habits mean a longer life, better efficiency, and safer operation. Please follow the Maintenance Schedule below. Keep good records of the hours the auger has been operated and the maintenance performed.

Daily:
Section 7.3 – Visually Inspect the Equipment on page 40
Section 7.4 – Lubricate the Equipment on page 41
Monthly:
Section 7.5 – Inspect Hydraulic Hoses and Fittings on page 45

Section 7.8 – Check the Gearbox Oil Level on page 48
Annually:
Section 7.4 – Lubricate the Equipment on page 41
Section 7.7 – Oil and Adjust the Chain Drives on page 46
Section 7.10 – Clean and Wash the Equipment on page 48
2–3 Years:
Section 7.9 – Change the Gearbox Oil on page 48
Section 7.7 – Oil and Adjust the Chain Drives on page 46
Section 7.6 – Inspect and Service the Hydraulic Winch and Lift Cable on page 45
As Required:
Section 7.11 – Repack the Wheel Bearings with Grease on page 49
Section 7.13 – Replace the Shear Bolt on page 52
Section 7.12 – Check/Adjust the Truss Cables on page 50

7.3. Visually Inspect the Equipment

 **WARNING** Lock out power before inspecting.

Check the following during a visual inspection:

1. Ensure all guards are in place and in good working order.
2. Examine the auger for damage or unusual wear.
3. Check tightness of bolts/nuts, fasteners, and hardware (re-torque if necessary).
4. Be sure all safety decals are in place and are legible.
5. Check that the discharge and intake area are free of obstructions.
6. Inspect all moving or rotating parts to see if anything has become entangled in them. Remove any entangled material.
7. Inspect hydraulic hoses and fittings for leaks and wear. Fix or replace where necessary.
8. Check wheel bolts are tight and examine tires for gashes, uneven wear, or loss of air pressure. See [Section 9. – Specifications on page 56](#) for recommended tire pressure and torque information.
9. Check all operating, lifting, and transport components. Replace damaged or worn parts before using the auger.
10. Inspect the auger shaft bushing for unusual wear or discoloration.
11. Check the PTO shield & replace if damaged.
12. Inspect the truss cables for proper tension and possible damage such as fraying, kinking, or unwinding.
13. Inspect the winch cable for fraying, kinking, unwinding, or other possible damage.

7.4. Lubricate the Equipment

Your equipment can operate at top efficiency only if clean fluids and lubricants are used. Use clean containers to handle all fluids and lubricants. Store them in an area protected from dust, moisture, and other contaminants.

1. Wipe the grease fittings with a clean cloth before greasing to avoid injecting dirt and grit.
2. Use a hand-held grease gun for all greasing.
3. If fittings will not take grease, remove and clean thoroughly.
4. Replace fittings if they are broken or will not accept grease.
5. If Intake Bushing is present in your auger, lubricate it.

Use SAE multi-purpose high-temperature grease with extreme pressure (EP) performance. SAE multi-purpose lithium-based grease is also acceptable.

7.4.1 Daily Grease and Lubrication

PTO Shaft Grease Locations

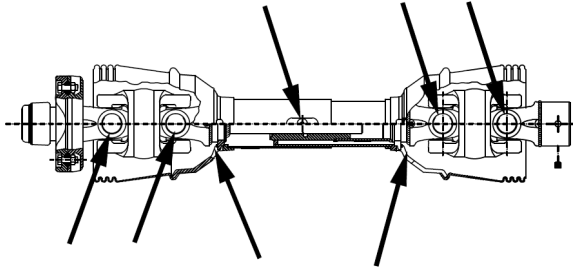

Vertical Shaft Grease Locations

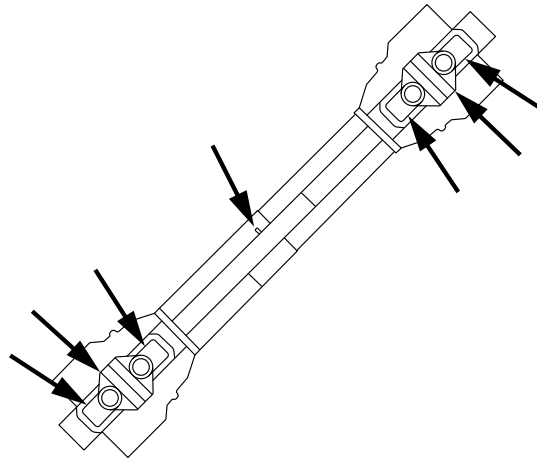

Swing-Away U-Joint Grease Locations

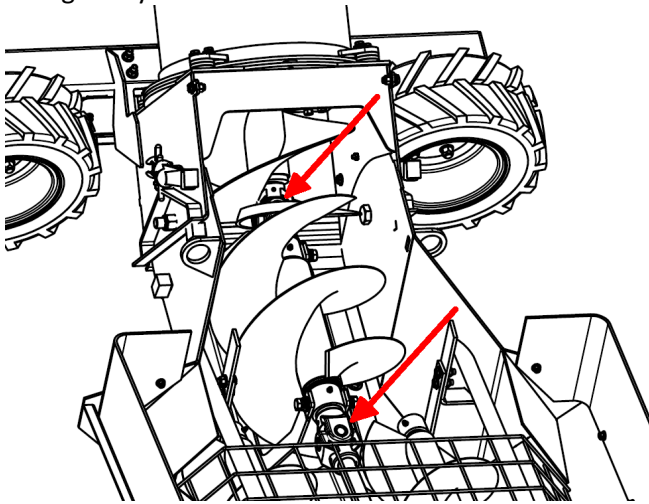

Swing-Away Splined Shaft Lubrication

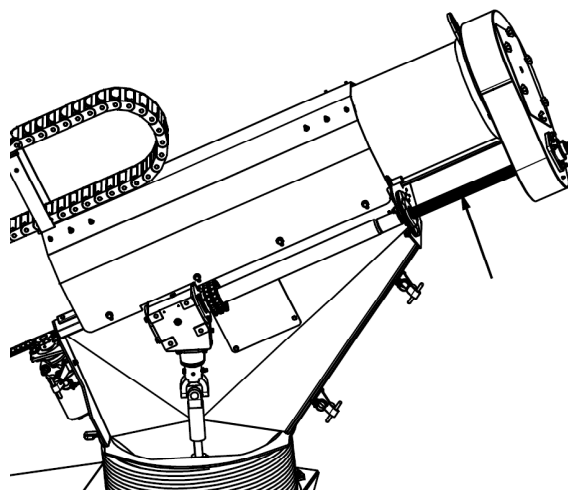

7.4.2 Periodic Grease Locations

Figure 17. Frame Grease Locations

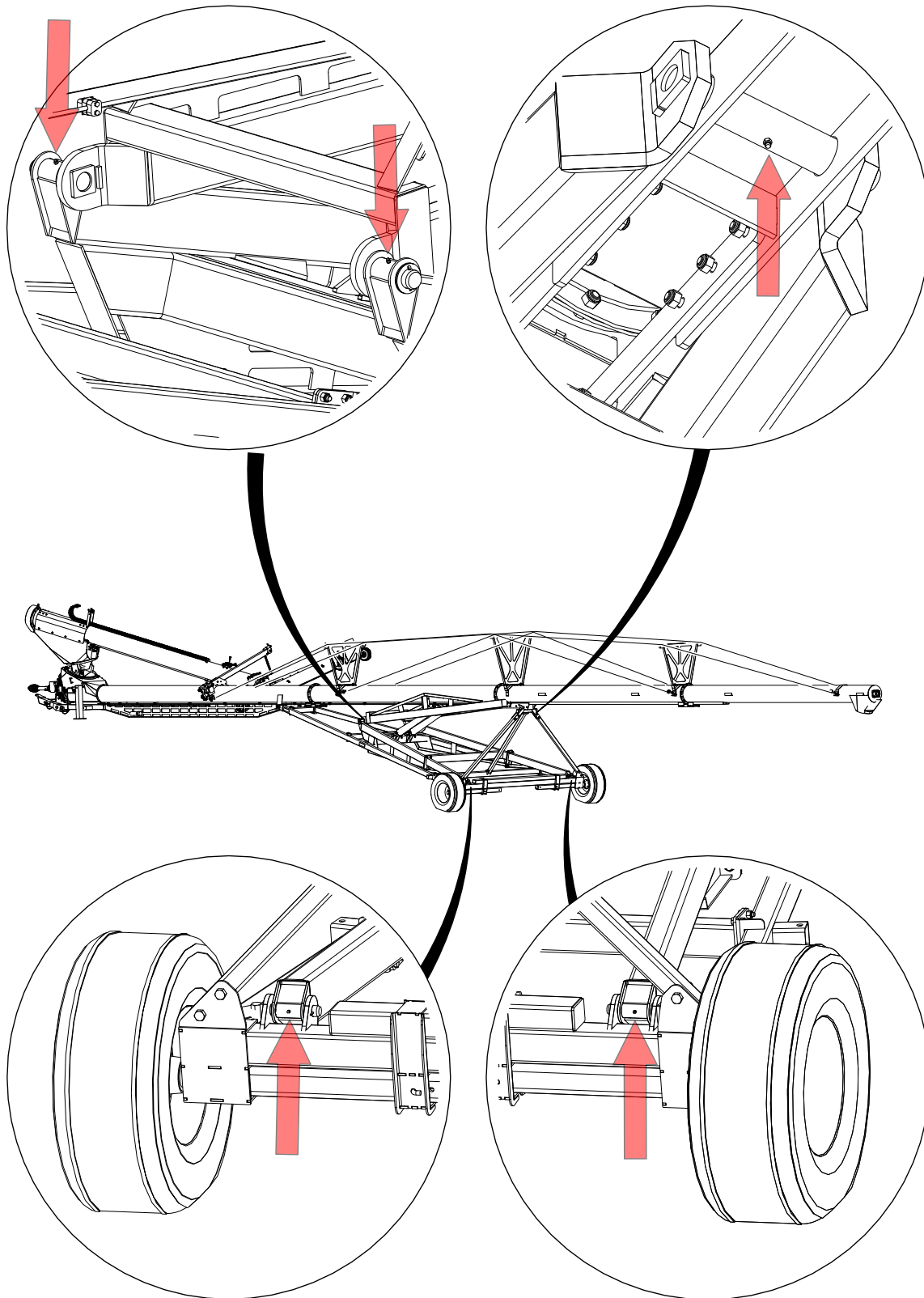

Figure 18. Lift Cylinder and Upper/Lower Bearing Grease Locations

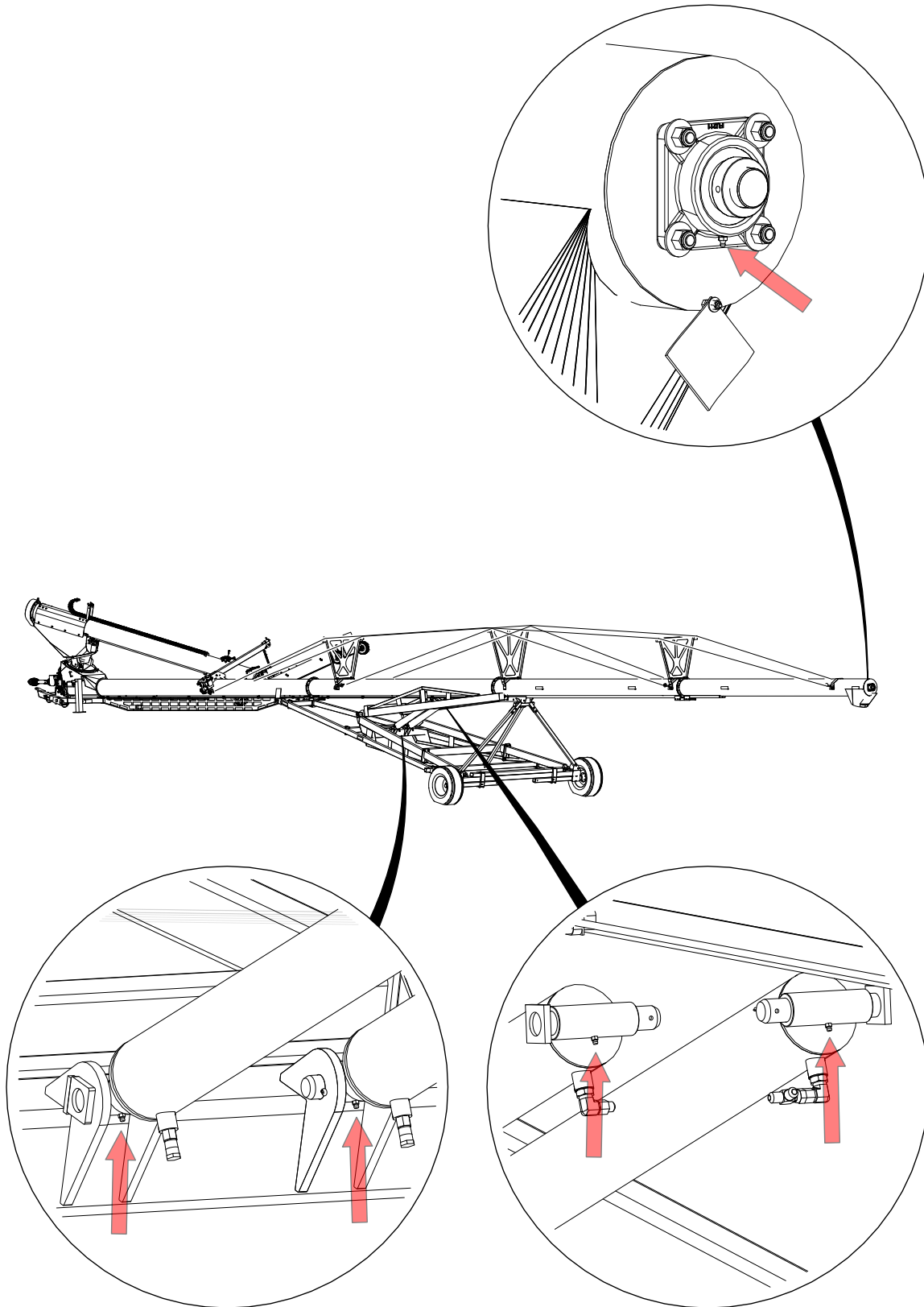
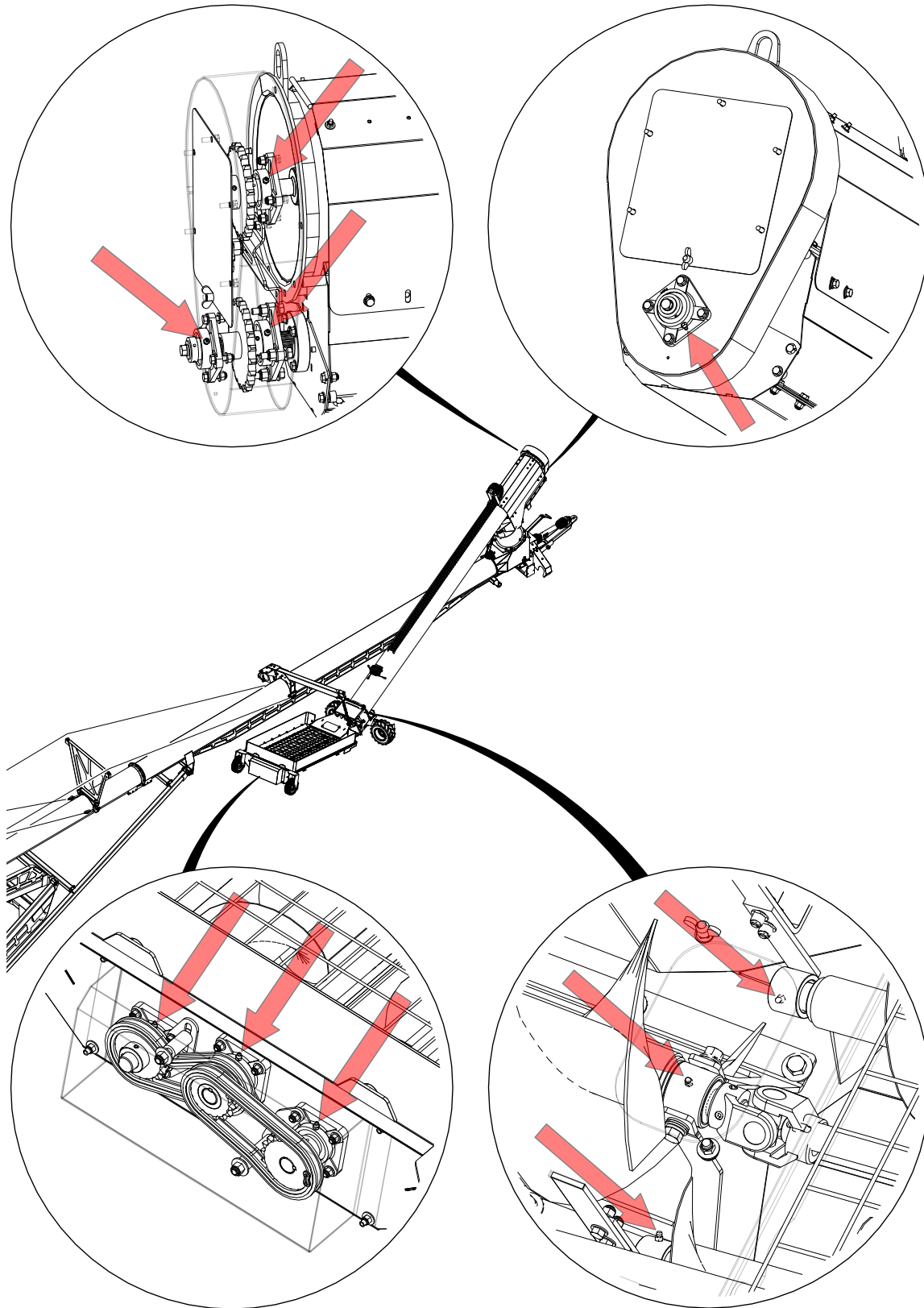

Figure 19. Swing-Away Grease Locations



7.5. Inspect Hydraulic Hoses and Fittings

➡ When equipped:

1. Pressurize the system.
2. Using a piece of cardboard or wood, run it along the length of the hose and around all fittings.

⚠ WARNING

 Escaping hydraulic fluid under pressure will cause serious injury if it penetrates the skin surface.
3. Replace the hose or tighten/replace the fitting if a leak is found. For replacement hoses, refer to [Section 9. – Specifications on page 56](#).
4. Replace any hose that is badly cut, nicked, abraded, or is separating from the crimped end of the fitting.
5. Secure hoses to the machine.

7.6. Inspect and Service the Hydraulic Winch and Lift Cable

➡ When equipped:

⚠ WARNING Place the auger in the fully lowered position with the cable slack.

To Inspect the Lift Cable:

1. Inspect the cable for damage such as fraying, kinking, or unwinding. Replace if damaged (see below).
2. Check to make sure the cable clamps are secure.
3. Oil the cable pulleys as needed.
4. Keep a film of grease on the gears. Occasionally oil the bushings, drum shaft, and ratchet.

Figure 20. Cable Pulleys

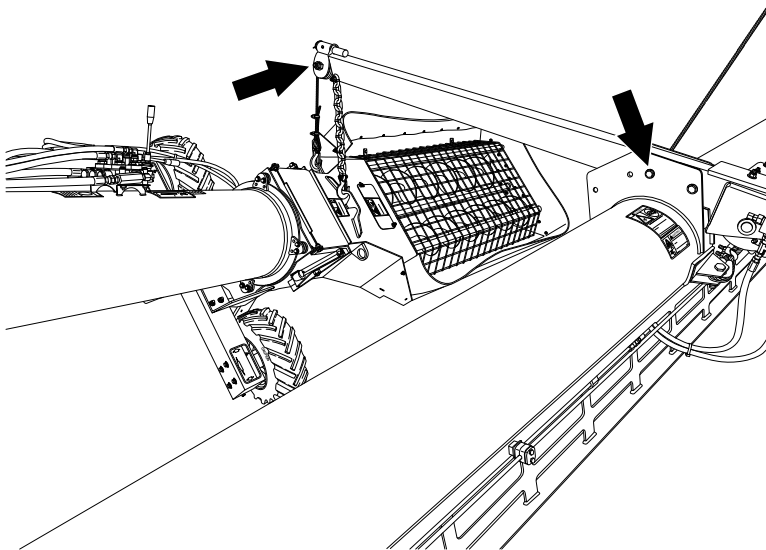

To Replace the Lift Cable:

1. Unwind the winch drum until the cable is slack and remove the cable clamps.
2. Free the cable from the winch and pulleys.
3. Remove the cable clamps that secure the hook in place.
4. Reverse the above steps to install the new cable.

7.7. Oil and Adjust the Chain Drives

There are three chain drives to check, located at the hopper, mover, and collector.

Hopper Chain

1. Remove the cover plate.
2. Check the chain slack at the middle of the longest span. It should move slightly.

Note

The hopper has two chains, one for each flighting.

3. Oil the roller chain.

Figure 21. Hopper Chain

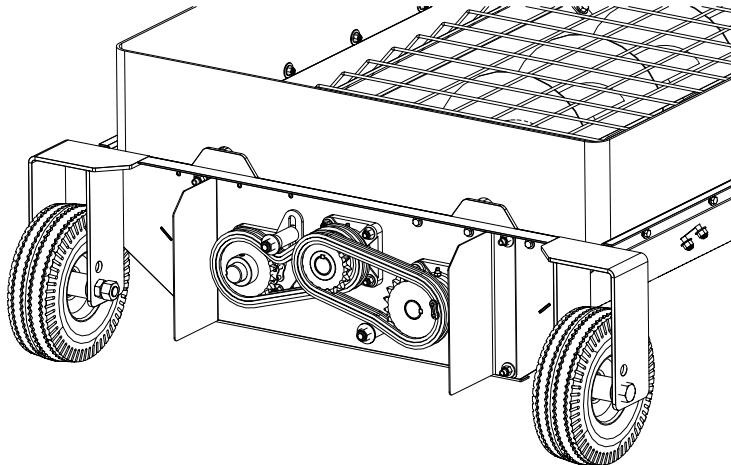
**Mover Chain**

1. Remove the cover plate.
2. Check the chain slack at the middle of the longest span does not move more than 1/4". To tighten, loosen the 4 bolts on the motor side of the housing and tighten the draw bolt on the end of the housing as required. Re-tighten the 4 spindle bolts and replace the stiffener plate.

Note

The mover has two chains, one for each wheel.

3. Oil the roller chain.

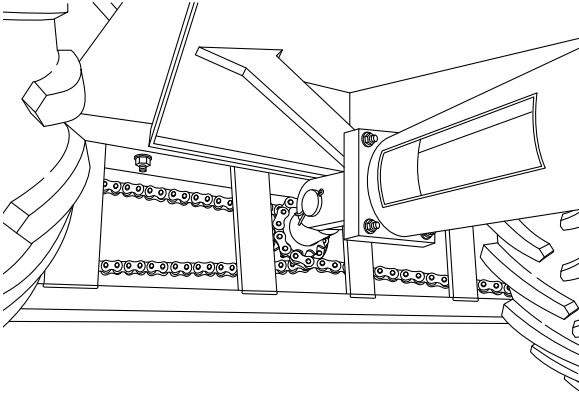
Figure 22. Mover Chain**Collector Chain**

1. Remove the cover plate.
2. Check the chain slack at the middle of the longest span. It should move no more than 1/4". Adjust the chain roller as required.
3. Oil the roller chain.

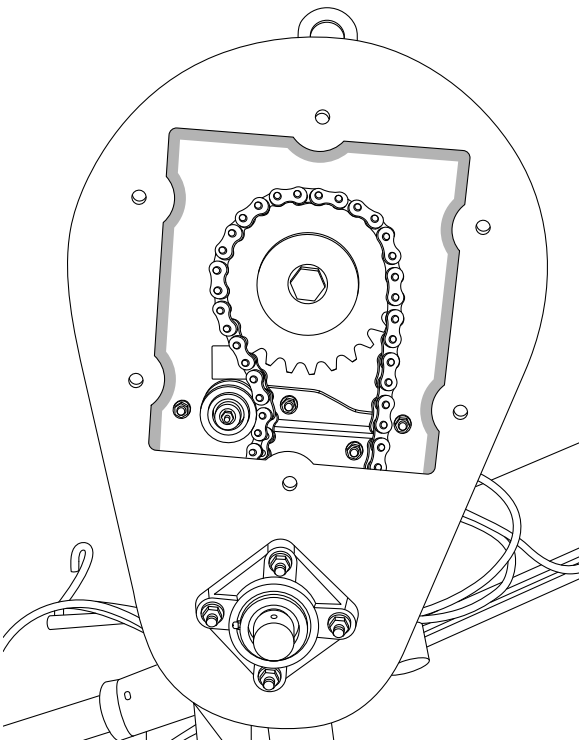
Figure 23. Collector Chain

7.8. Check the Gearbox Oil Level

Gearbox Locations

There are three gearboxes, one on the front and two inside the swing-away spout.

Upper Gearbox: Unfasten latches, open spout-head lid, and service gearbox as required.

Lower Gearbox: Open square service door and service gearbox as required.

Reducing Gearbox: Large gearbox on front of auger.

Checking and Adding Oil for Upper/Lower Gearbox

1. Remove the plug from the side of the gearbox.
2. Check if the oil level comes to the bottom of the plug hole.
3. Add 75W90 synthetic gear oil as needed.

Checking and Adding Oil for Reducing Gearbox

1. Check the gearbox to confirm that the oil level is half way up the sight glass.
2. Add 75W90 synthetic gear oil as needed.

7.9. Change the Gearbox Oil

For gearbox locations, refer to [Section 7.8 – Check the Gearbox Oil Level on page 48](#).

1. Place a pan under the drain plug.
2. Use a wrench and remove the drain plug.
3. Loosen the filler plug so air can enter the gearbox and the oil will drain freely.
4. Allow the oil to drain completely.
5. Replace the drain plug.
6. Add 75W90 synthetic gear oil. **Do not overfill.**
 - a. **Upper and Lower Gearbox:** Fill the gearbox half full (center of cross shaft).
 - b. **Reducing Gearbox:** Fill the gearbox half way up the sight glass.

7.10. Clean and Wash the Equipment

1. Clean out excess grain from all areas of the auger.
2. Make sure water can drain from the auger tube and intake, then wash the tube with a water hose or pressure washer until all dirt, mud, debris, or residue is gone.

Important

Do not contact electronic controls with high pressure washer.

3. Provide sufficient time for the water to drain from the auger.

7.11. Repack the Wheel Bearings with Grease

1. Block wheels and ensure unit is stable.
2. Remove the wheel bolts and the wheels.
3. Clean wheel and hub mounting surfaces to ensure there is no rust or debris.
4. Remove the wheel bearing and pack with grease. Use SAE multi-purpose high-temperature grease with extreme pressure (EP) performance. SAE multi-purpose lithium-based grease is also acceptable.
5. Tighten the wheel bolts (diagonal pattern) with a torque wrench to 100 ft-lb (± 10 ft-lb) of torque. Inspect to make sure the wheel is sitting flush with the hub.

Figure 24. Diagonal Pattern for 4-bolt and 6-bolt Tires

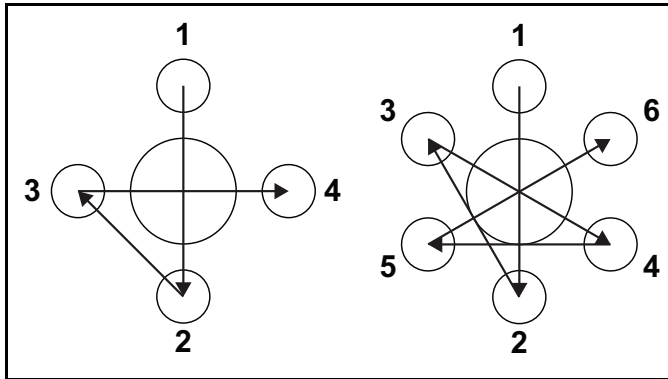

7.12. Check/Adjust the Truss Cables

Check the auger tube for side-to-side straightness, no slack in the cables, and a just noticeable upward deflection of the discharge end. During operation, it is normal for the tube to deflect downward. Follow the procedure below to keep cables tight and the tube in the correct position.

If the auger has multiple truss cables, start with the innermost cables and work your way out.

1. Lift the discharge end of the auger with an overhead crane, front end loader, or other proper lifting device so that the tube has a slight upward deflection at the discharge and the cable has some slack.

CAUTION The lifting device must be capable of supporting approximately half of the weight of the auger as provided in the Specifications section.

2. Loosen cable clamps on cable truss tower(s) where the cable requires adjustment.

Figure 25. Cable Clamp

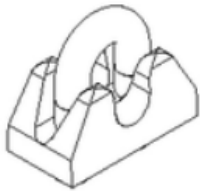

3. Locate the eyebolt anchors for the cable.

Figure 26. Eyebolt Anchor

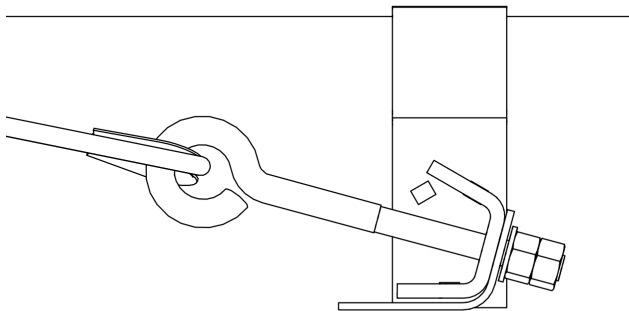

4. Tighten cable eyebolts evenly on both sides (use eyebolt nuts to tighten eyebolts) until the discharge end just starts to angle upward.
 - The tube should not deflect to the left or right if tightened evenly.
 - Tension should be greater on shorter cables than on longer cables. If the auger tubes remain straight then the cables are tensioned properly.
- ➔ 5. **74105 Only:** This auger is equipped with cables that run along each side of the tube to help prevent side-to-side deflection. This tube can be additionally straightened from side-to-side by first loosening the cable clamps along the side cable and then tightening the turnbuckles on the side the tube is deflecting away from. Re-tighten the cable clamps once corrected.

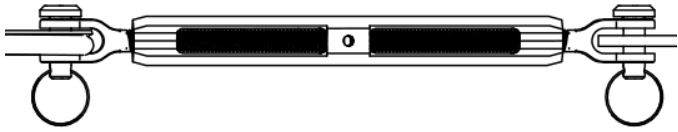
Figure 27. Turnbuckle

6. If the proper cable tension can't be obtained before the eyebolts run out of adjustment, do the following:
 - a. Loosen the eyebolts.
 - b. At the eyebolts, loosen the cable clamps, shorten the cables until there is tension on the cable, then tighten the cable clamps fully.
 - c. Return to step 4.

WARNING Cable must be re-installed **exactly** as shown or it could come loose.

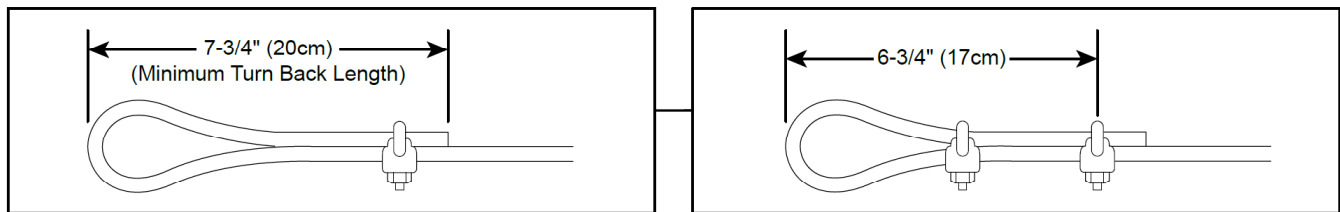
Figure 28. Cable Re-Installation

7. Secure jam nut on cable eyebolt and re-tighten any cable clamps that were loosened.

7.13. Replace the Shear Bolt

The PTO is equipped with a shear bolt to protect against overloads.

To replace shear bolt:

1. Remove yoke from the shaft on the lower gearbox or the tractor.
2. Remove the shear bolt parts remaining in the yoke.
3. Install a new shear bolt and tighten. Refer to [Section 9. – Specifications on page 56](#) for shear bolt type.
4. Install yoke on the shaft and lock in place.

Figure 29. Shear Bolt Location

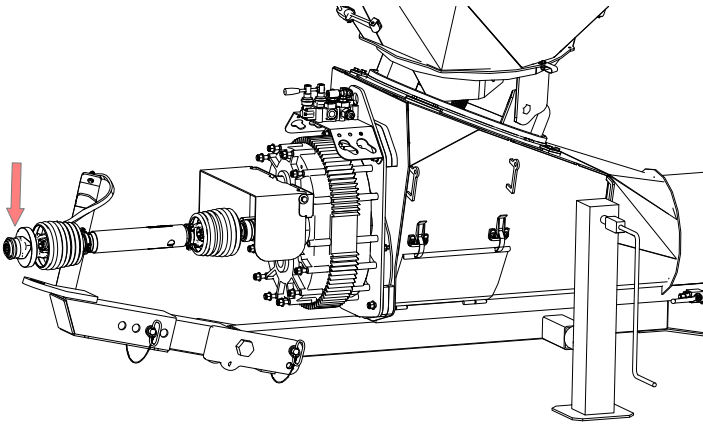

8. Troubleshooting

⚠ WARNING Shut down and lock out all power sources before diagnosing any of the causes or attempting any of the solutions below.

In the following section, we have listed some causes and solutions to some of the problems you may encounter.

If you encounter a problem that is difficult to solve, even after having read through this section, please contact your local dealer or distributor. Before you contact them, please have this operation manual and the serial number from your machine ready.

Auger

Problem	Cause	Solution
Poor product flow.	Input speed is too slow.	Increase engine rpm.
	Inadequate material flow from truck or hopper.	Increase flow of material.
	Flow into the hopper is restricted.	Clear grating of obstructions.
	Material is too wet or heavy.	Unloading rates are for dry grain.
	Flighting is worn.	Repair or replace as required.
The flighting does not turn.	Auger flighting is plugged or obstructed.	Identify and remove obstruction.
	The coupler bolt below the non-rotating section is broken or missing.	Replace the bolt.
	Bearing is seized.	Identify the bearing and replace.
	A chain is broken.	Identify the chain and repair or replace.
	Gearbox is seized.	Fix or replace the gearbox.
	Gearbox coupler bolt is broken or missing.	Replace the bolt.
	A PTO shear bolt has failed.	Replace both PTO shear bolts.
Auger flighting is noisy.	Obstruction in the auger tube.	Identify and remove obstruction.

	Flighting shaft bolts are loose or damaged.	Tighten or replace bolts.
	Flighting shaft is bent.	Repair or replace flighting shaft.
	Flighting is damaged.	Repair or replace flighting.
	Worn bearing.	Repair or replace bearing.
	Low gear oil level.	Inspect the gearbox, replace if damaged or add oil if not damaged.
Tube is misaligned.	Loose truss cables.	Tighten cables as required.

Scissor Lift Frame/Undercarriage

Problem	Cause	Solution
Scissor lift not lifting auger.	Ball valve on lift line closed.	Open ball valve.
	Inadequate pressure from source.	Use alternate hydraulic pressure source; contact your local dealer for assistance.
The auger lifts slowly.	Inadequate hydraulic pressure from source.	Use alternate hydraulic pressure source; contact your local dealer for assistance.
	If auger lowers faster than it lifts, then the check valve may be installed in opposite direction.	Lower auger to transport position and inspect check valve; re-install in opposite direction if required (see indicator arrow on valve).
The auger will lift but not lower.	Foreign object clogging check valve.	Contact your local dealer for assistance.
The auger will not stay elevated.	Ball valve not closed while in elevated position.	Close ball valve.
	Leaking hydraulic hose or fitting.	Lower auger to transport position and repair leaks as required.
	Leaking seal in hydraulic cylinder.	Lower auger to transport position and repair or replace winch.
The auger makes noise while lifting.	Frame parts loose and move while lifting.	Replace damaged components and re-tension frame fasteners.

Lift cylinder discharges oil from breather while lifting.	If auger lifts, this is just captured oil in the top of the cylinder.	Clean up oil spill and continue operation as normal.
	If auger will not lift, seal in hydraulic cylinder is damaged.	Lower auger to transport position and repair hydraulic cylinder as required.

9. Specifications

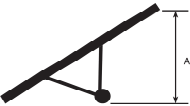
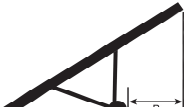
		7485	7495	74105
Capacity		14,100 – 15,000 Bu/Hr		
Tube Size		14" (36 cm)		
Transport	Length	90' (27.4 m)	100' (30.5 m)	110' (33.5 m)
	Width (axles in transport)	12'4" (3.76 m)	12'4" (3.76 m)	12'4" (3.76 m)
	Width (axles extended)	13'8" (4.16 m)	13'8" (4.16 m)	13'8" (4.16 m)
	Height	12'6" (3.81 m)	13'6" (4.11 m)	15' (4.57 m)
Discharge Clearance (A) 	Up	51' (15.5 m)	55'6" (16.9 m)	59' (18.0 m)
	Down	12' (3.65 m)	13' (3.96 m)	14' (4.27 m)
Reach to Wheels (B) 	Up	27' (8.22 m)	35'6" (10.8 m)	44' (13.4 m)
	Down	35' (10.7 m)	44' (13.4 m)	55' (16.8 m)
Tires	Type	11L15 -8 ply rib implement tires, 55 mph highway speed rated		
	Inflation Pressure	Refer to tire sidewall		
Total Weight		Contact Factory		
Hitch Weight		Contact Factory		
Hitch Pin		1-1/4" x 5"		

		7485	7495	74105
Hitch Jack		10,000 lb		
PTO Drive	Power Requirements	160–180 HP	180 HP	180–200 HP
	PTO Speed	1000 RPM		
	PTO Shaft	Weasler 1-3/8" diameter, 21 spline		
	Max. Operating Angle	25°		
Upper/Lower Gearbox Oil	Capacity	37 oz (1.1 L)		
	Type	75W90 synthetic gear oil		
Reducer Gearbox	Capacity	3.5 L (or halfway up sight glass)		
	Type	75W90 synthetic gear oil		
Shear Bolts		3/8" x 1" GR 8 Bolt		
Grease		SAE multi-purpose high temperature grease with extreme pressure (EP) performance, OR use SAE multi-purpose lithium base grease.		
Chain and Shaft Lubricating Oil		Standard automotive oil		

10. AGI GrainMaxx Limited Warranty

This warranty relates to AGI GrainMaxx augers (the “Product”) sold by Ag Growth International Inc., (referred to herein as the “Seller”) and applies only to the first user of the Product (meaning a purchaser directly from the Seller or from an authorized dealer or distributor of the Product, referred to herein as the “Buyer”).

This warranty shall only be effective if properly registered with the Seller in accordance with information provided to the Buyer at the time of sale.

1. The Seller warrants to the Buyer that the Product is free from defects in material and workmanship **under normal and reasonable use** and in accordance with manufacturer’s manual.
2. This warranty applies only to defects in materials and workmanship and not to damage incurred in shipping or handling, through normal wear and tear, or damage due to causes beyond the control of the Seller such as lightning, fire, flood, wind, earthquake, excessive voltage, mechanical shock, water damage, or damage arising out of abuse, alteration, improper assembly, improper installation, improper maintenance or improper repair of the Product.
3. **The warranty period for the Product shall be two years from delivery of the Product to the Buyer where the Product is used in a normal farm operation. First year of warranty coverage of parts and repair labour, second year warranty coverage of parts only. Warranty period for the Product shall be 90 days from delivery of the Product to the Buyer where the Product is used in a commercial operation.** In the event that any part incorporated into the Product is manufactured and sold to the Seller by a third party vendor, such part is only warranted to the extent of the warranty given by that third party.
4. This warranty does not obligate the Seller to bear costs of travel in replacing defective parts.
5. The obligations set forth in this warranty are conditional upon the Buyer promptly notifying the Seller of any defect and completing reasonably required documentation and, if required, promptly making the Product available for correction.
6. The total liability of the Seller on any claim, whether in contract, tort or otherwise, arising out of, connected with, or resulting from the manufacture, sale, delivery, repair, replacement or use of the Product or any part thereof **shall not exceed the price paid for the Product** and the Seller shall not be liable for any special, indirect, incidental or consequential damages caused by reason of the installation, modification, use, repair, maintenance or mechanical failure of the Product. **Consequential or special damages as used herein include, but are not limited to, lost or damaged products or goods, costs of transportation, lost sales, lost orders, lost income, increased overhead, labor and incidental costs and operational inefficiencies.**
7. The foregoing warranty is the entire warranty of the Seller to the Buyer and the Buyer shall not be entitled to rely upon any representation or warranty contained in any marketing material of the Seller in respect of the Product. The Seller neither assumes, nor authorizes any other person purporting to act on its behalf to modify or to change this warranty, nor to assume for it any other warranty or liability concerning the Product.

WARRANTY VOID IF NOT REGISTERED



201 Industrial Drive, Swift Current
Saskatchewan S9H 5R4, CANADA
Phone: (877) 667-7421 (Canada & USA)
or (306) 773-7779
Fax: (306) 778-2524

Email: sales@batco-rem.com
Website: www.aggrowth.com
©Ag Growth International Inc. 2021
Printed in Canada

If you have any comments or questions on this manual, or find an error, email us at comments@aggrowth.com.
Please include the part number listed on the cover page in your message.