



Inductive Proximity
Sensor/Switch

1-WIRE[®] Sensor Bus

mIP001

mIP001 Inductive Proximity Sensor/Switch Technical Manual



Document No. 11910, Revision A01

April 2016

This page intentionally left blank.



Table of Contents

1. Overview.....	1
2. Description of indicators.....	3
3. Sensor Installation	4
4. Sensor Calibration	5
5. Sensitivity Settings.....	11
6. Digital signal processing	12
7. Communications	13
8. Specification	15

Table of Figures

Figure 1: Illustration of Indicators.....	3
Figure 2: Sensing area on tip of sensor	4
Figure 3: Sensing area on side of sensor.....	4
Figure 4: Turning EZTester on & FW version verification.....	5
Figure 5: Entering Sensor Configuration Menu	5
Figure 6: Serial Number and Getting Configuration Screens	6
Figure 7: LED code during Getting Configuration Process.....	6
Figure 8: Status Indication	7
Figure 9: Calibration Menu #1	7
Figure 10: Calibration Menu #2.....	8
Figure 11: Calibration Menu #3.....	8
Figure 12: Recalibration Option Chosen	8
Figure 13: Recalibration Option Saving.....	9
Figure 14: LED code indicates that calibration is finished	9
Figure 15: LED code when sensor is calibrated	10
Figure 16: Proximity Data at Calibration.....	11



Revision History

REV	Description	Date	App.
A00	First Release	June 3/15	
A01	Dimensions for Installation Added	April 4/16	



1. Overview

The mIP001 Inductive Proximity Sensor/Switch is designed to detect conductive target. The detection is contact-less. Sensing distance may be set by EZTester. Range of the distance is between 0 mm and 15 mm. The sensor sets output target detection “ON” when target detected and “OFF” if target is not detected.

Each sensor has a unique digital serial number and will be automatically recognized by CMCIEL Bus Converters. Communications utilize the Dallas 1-Wire[®] bus standard. Power for the sensor is supplied by the bus system.

The sensors are packaged in a polycarbonate tube housing utilizing a fully potted construction. Each sensor comes complete with 2 meters of heavy-duty industrial cable rated for use in direct sunlight. The cable is terminated with an RJ-11 connector for direct connection to CMCIEL wiring accessories. The housing incorporates a ½” female conduit fitting for attaching liquid tight conduit.

When used with the mBC081/83 Bus Converters the device is Intrinsically Safe.



This page intentionally left blank.



2. Description of indicators

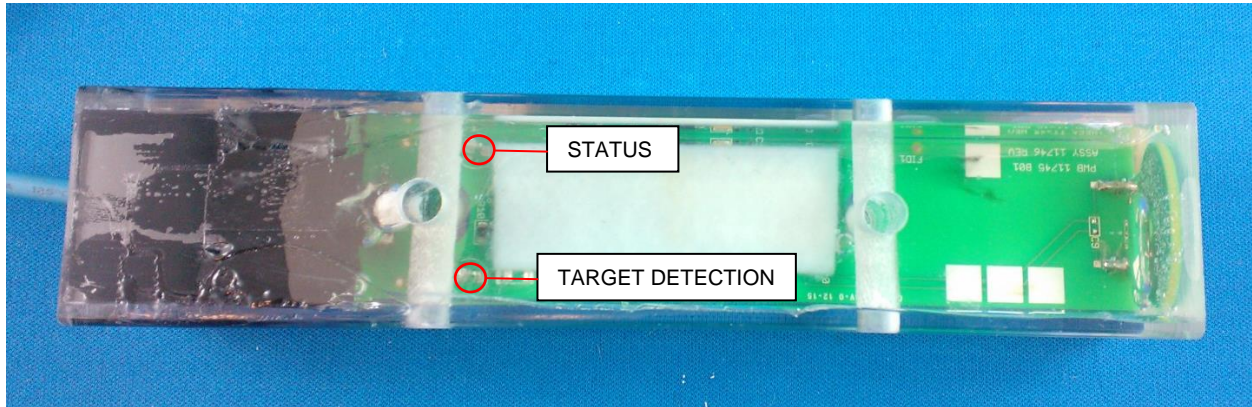

Figure 1: Illustration of Indicators

There are two indicator lamps:

Description	Color	Flash Rate	Operation
Status	Green	1	Ok, no communications
		2	Ok, communication active
		3	RAM read/write fault
		4	Sensor access fault
		5	Firmware fault
		6	Serial number fault
Target Detection	Red	on	Target detected
		off	No target detected

During calibration, both red and green LEDs are on, they turn off when calibration completed.



3. Sensor Installation

There are two versions of the sensor. The first one has a sensing area on a tip of the sensor. The second one has a sensing area on one side of the sensor. See following drawing for explanation.

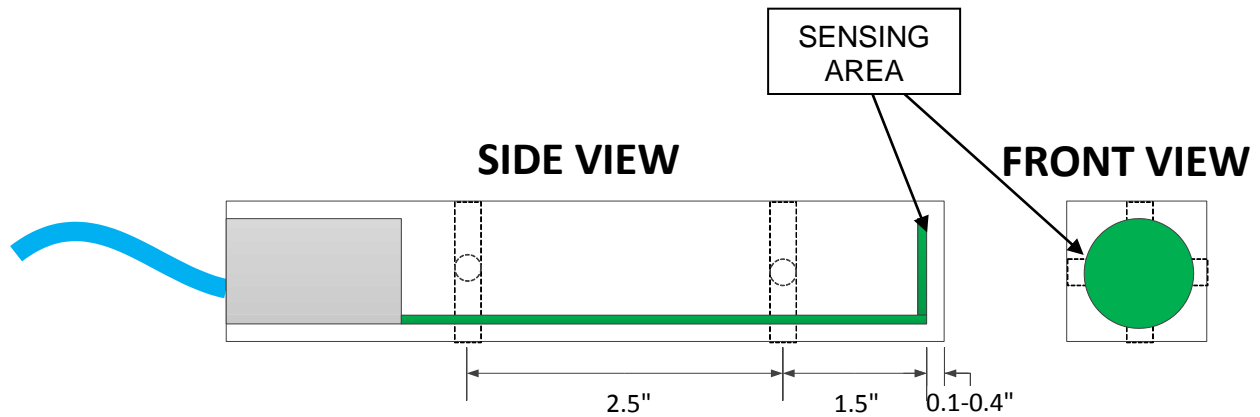

Figure 2: Sensing area on tip of sensor

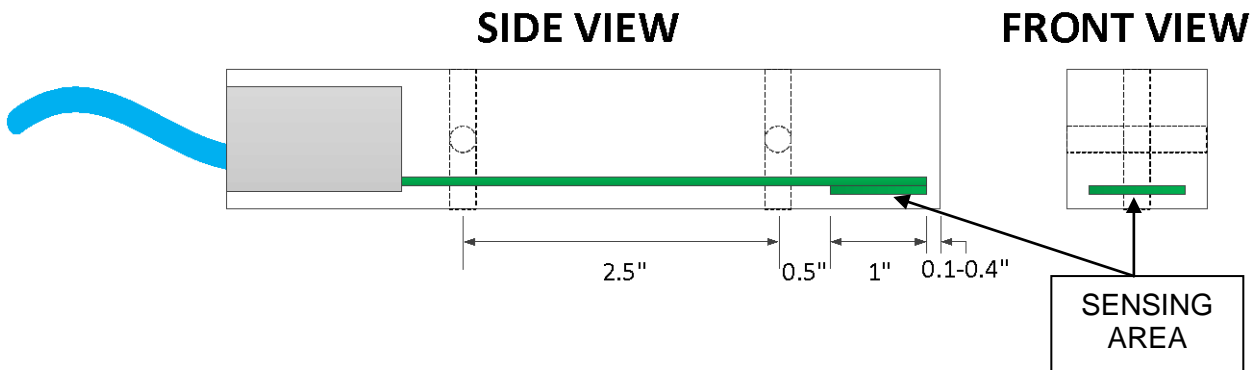

Figure 3: Sensing area on side of sensor

For proper installation are in the sensor four 15/64" predrilled holes for bolts.



4. Sensor Calibration

Sensor needs to be calibrated after each installation to get the best performance.

How to calibrate:

- Plug sensor into the EZTester
- Turn the EZTester on by holding “POWER” button down

NOTE: in startup menu read the FW version, to be able to configure mIP001 sensor you need version 2.00 and higher

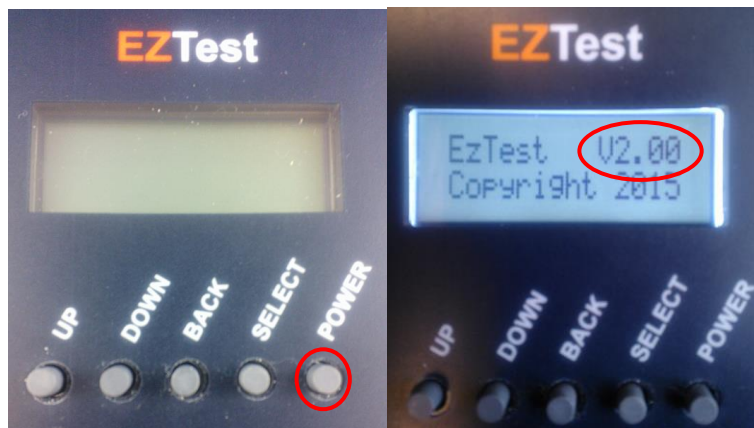

Figure 4: Turning EZTester on & FW version verification

- By pressing “UP” and “DOWN” buttons in “Select Function” menu choose “Sensor Config” and press button “SELECT”

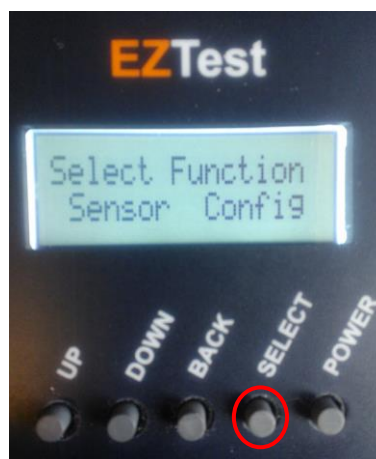

Figure 5: Entering Sensor Configuration Menu



- In case you get a message “Connect Sensor to Configure” even when the sensor is plugged, press “BACK” button and “SELECT” button again
- EZTester will show serial number of the sensor and then starts to pull data from the sensor as on following pictures
- Status LED in this step should be blinking twice in 3 seconds intervals to indicate that sensor is working properly and that communication is in progress, red LED may be either on or off

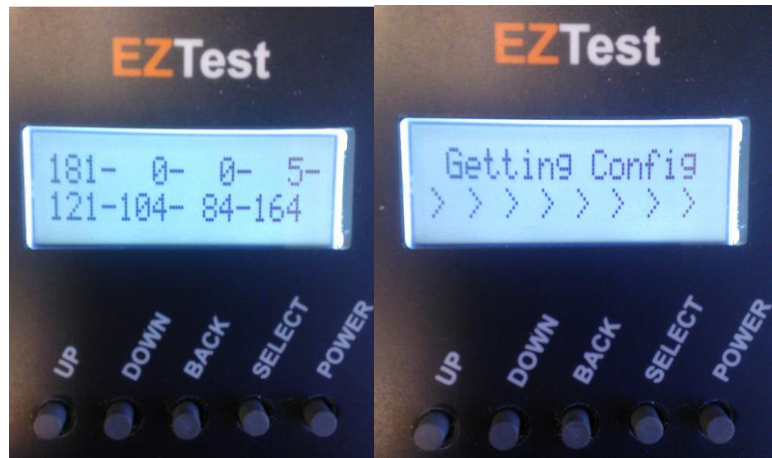

Figure 6: Serial Number and Getting Configuration Screens

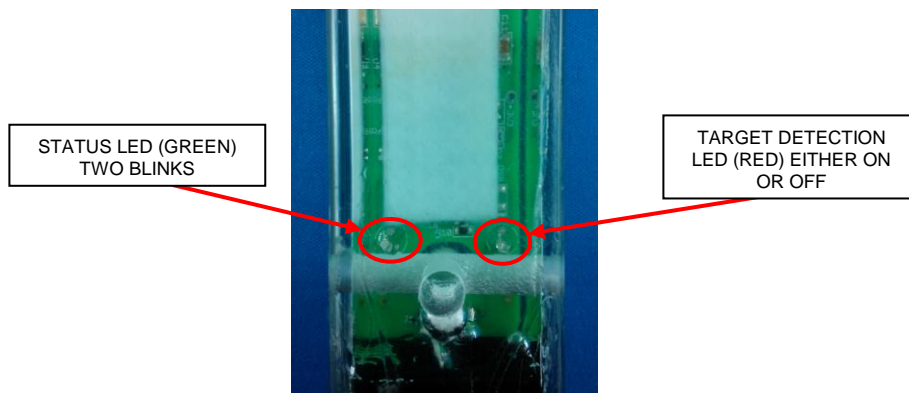

Figure 7: LED code during Getting Configuration Process



- After getting into the configuration menu the status LED should blink once in 3 seconds intervals to indicate that sensor is working properly and no communication in progress, target indication LED can be either on or off

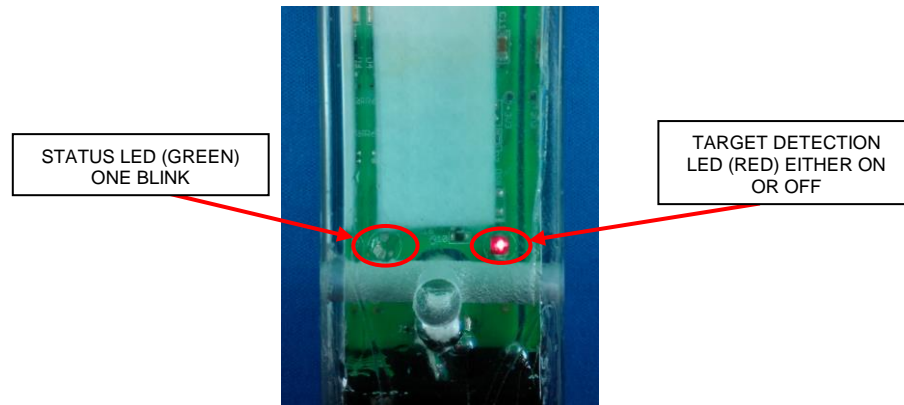

Figure 8: Status Indication

- When you see following screen the sensor settings can be adjusted



Figure 9: Calibration Menu #1

- To calibrate the sensor press “SELECT” button, screen should be as follows

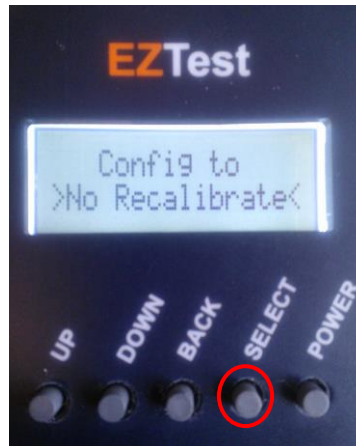

Figure 10: Calibration Menu #2

- By pressing “UP” or “DOWN” button change the sign from “No Recalibrate” to “Recalibrate” as follows and press “SELECT” button again to confirm

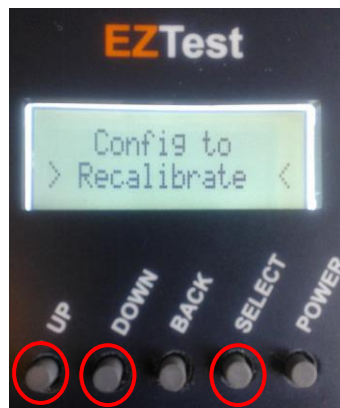

Figure 11: Calibration Menu #3



Figure 12: Recalibration Option Chosen

- When Recalibration option is chosen it also has to be saved. To do this keep pressing “DOWN” button till you get following screen

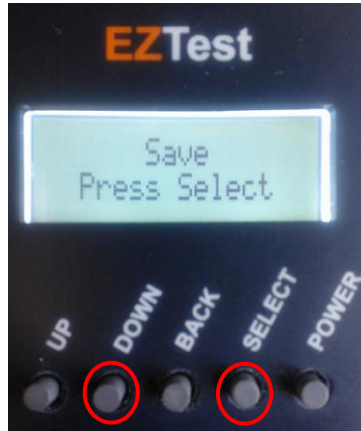

Figure 13: Recalibration Option Saving

- When you are in Save menu press “SELECT” button as the screen asks and check the LED code
- The calibration is finished when both LEDs are on at the same time for about 1 second, after that the target indication LED has to come off and status LED start to blink once

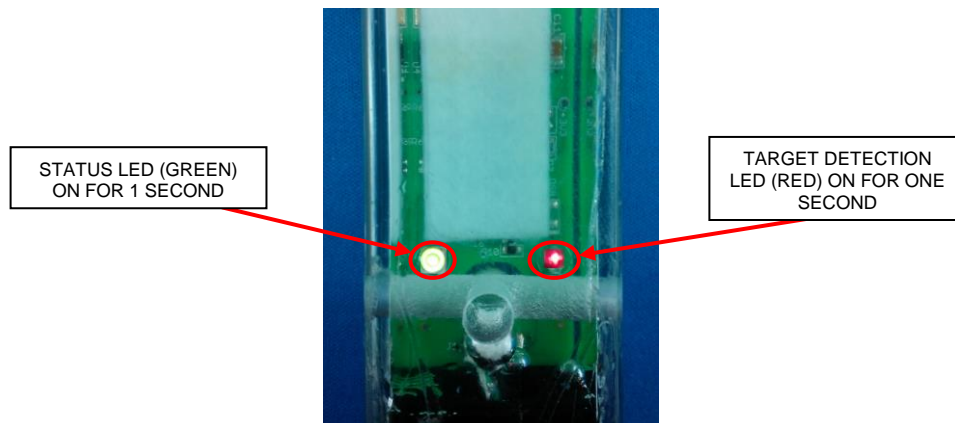

Figure 14: LED code indicates that calibration is finished

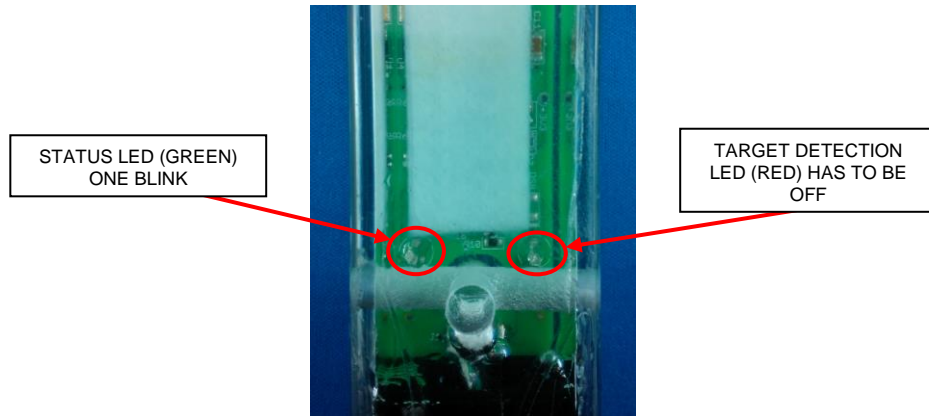

Figure 15: LED code when sensor is calibrated

- After calibration press “BACK” button to get back to the “Select Function” menu
- Sensor is ready to be used in that particular installation
- By calibration sensor saves value of proximity data without target into the memory as a Proximity Data at Calibration. For more information read the following chapter.



5. Sensitivity Settings

A conductive target can be detected by the sensor with different sensitivity. This allows to set the sensor to detect a target in different distances (from 0mm to 15mm).

Sensitivity can be changed by adjusting High and Low Threshold value. This value is adjusted in the same configuration menu as a calibration.

High & Low Threshold Setting

In configuration menu press “DOWN” button to get into the High Threshold menu, then press “SELECT” to be able to change a value of the High Threshold value



High Threshold value is a threshold when sensor reports target detection. The actual threshold is $[Proximity\ Data\ at\ Calibration\ (without\ target) + HIGH\ THD\ value]$. It means that when Proximity Data will be higher than set $[HIGH\ THD + Proximity\ Data\ at\ Calibration]$ the sensor output will be set ON and Target detection LED will be ON.

The Proximity Data at Calibration can be seen in the configuration menu as a last item in the menu when “DOWN” button is pressed. See following figure.

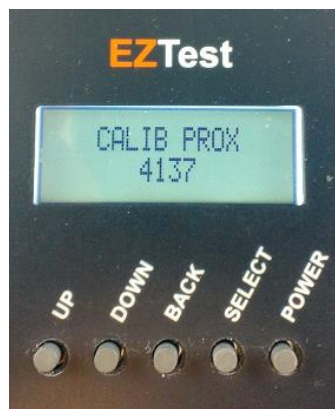

Figure 16: Proximity Data at Calibration

The same principle is for the Low Threshold. When the actual Proximity Data gets lower than $[Proximity\ Data\ at\ calibration + LOW\ THD]$ the sensor turns off the output and target detection LED will be off.



6. Digital signal processing

The sensor reads inductive proximity data which is affected by conductive material surrounded area, and compares the proximity data with reference value. If the difference is over the set Threshold, sensor's target detection status is set and target detection (red) LED goes ON. Reference value is set during calibration and is based on the calibration data and temperature compensation.

The sensor's target detection status is provided in a single 16bit integer value with a 0x0000 implied as no target detected, with 0x0001 implied as target detected.



7. Communications

The mIP001 Inductive Sensor is a fully compliant Dallas 1-Wire[®] device. The sensor is supplied with 2m of cable terminated with a RJ-11 plug. The sensor connects to the CMCIEL wiring system through a CMCIEL Field Interconnect.

The output of the sensor is a single 16bit word which simply indicates 0x0000 as no target detected and 0x0001 as target detected.

The sensor requires a bus converter to convert the Dallas 1-Wire[®] signaling system to a system recognized by commercial programmable controllers. The Bus Converters provide a Modbus485 RTU interface. CMCIEL manufactures Bus Converters for both commercial and hazardous areas. The target detection value, with 1 implied decimal place, is represented as a single signed word in the Bus Converter Modbus register map. See section 5 for information on the values presented. The Bus Converters will automatically acquire the serial number of the sensor on request.

As a Dallas 1-Wire[®] device, the sensor value is returned using the read scratch function as 3 bytes, the first 2 bytes a signed word containing the process value and the 3rd byte the Dallas 1-Wire[®] - 8 bit CRC. The family code for the sensor is 180 decimal or B4 Hex. The sensor responds to the following Dallas function codes:

Code Decimal	Code Hex	Function
240	F0	Search ROM
85	55	Match ROM
15	0F	Read ROM
51	33	Read ROM
204	CC	Skip ROM
190	BE	Read Scratch, 3 bytes, low byte + high byte + Dallas 8 bit CRC

Refer to Dallas Semiconductor documentation for complete details on the operation of the Dallas 1-Wire[®] signaling system.

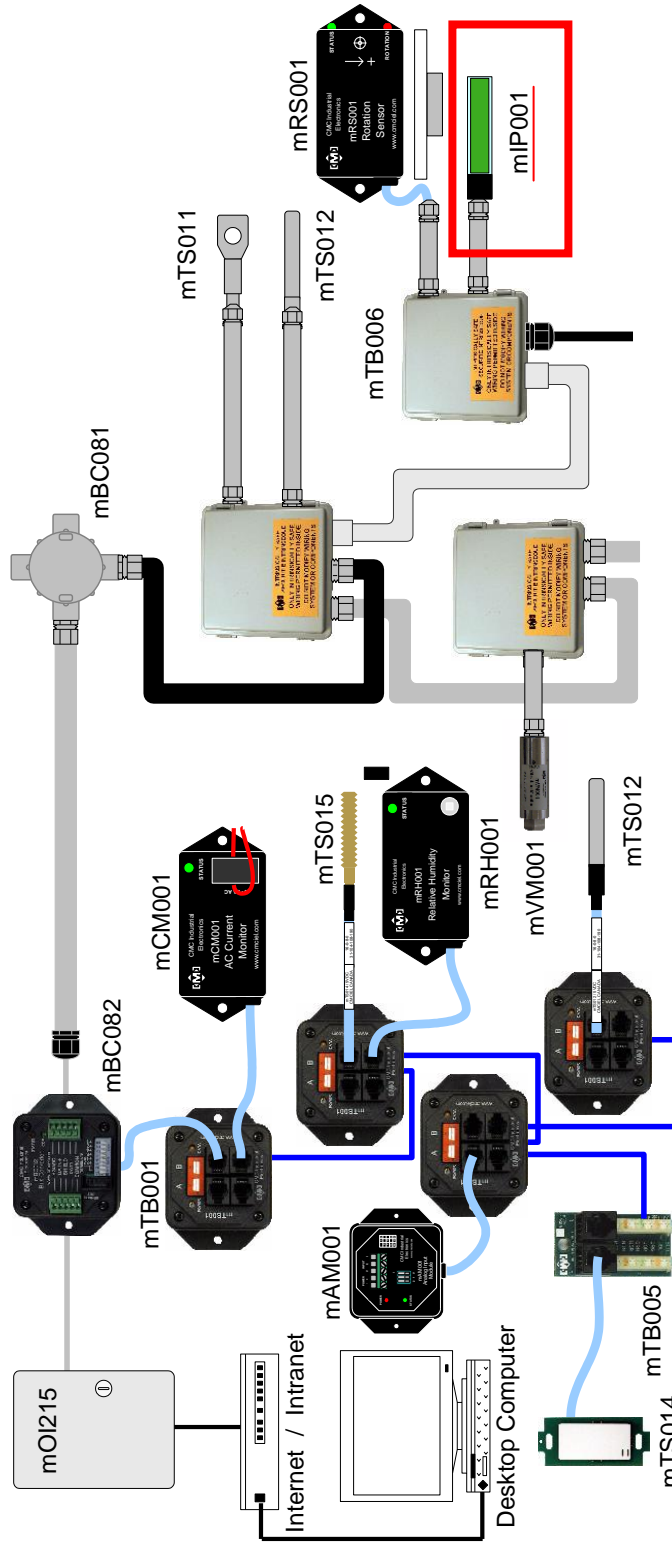

Indoor / Outdoor Industrial Application

Indoor Commercial Application



8. Specification

Description	Characteristic
Sensor bus	
Voltage	5 VDC
Current	8.0 mA max 3.0 mA avg.
Communications	1-Wire [®] Bus
Output	
Target Detection On	0x0000
Target Detection Off	0x0001
Environment	
Temperature	-40 to 70°C (-40 to 158°F)
Relative Humidity	0 to 100% non-condensing
Enclosure	Waterproof
Dimensions	
Length	6"
Body diameter	1.25"



This page intentionally left blank.