

REV	DESCRIPTION	DATE	DRAWN	APP.
A02	mDC001 REMOVED NAMING OF PARTS ADDED EZTESTER CONNECTION ADDED	APR 1/18	JP	VB
A03	SENSOR POSITION REPRESENTATION ADDED	APR 20/18		

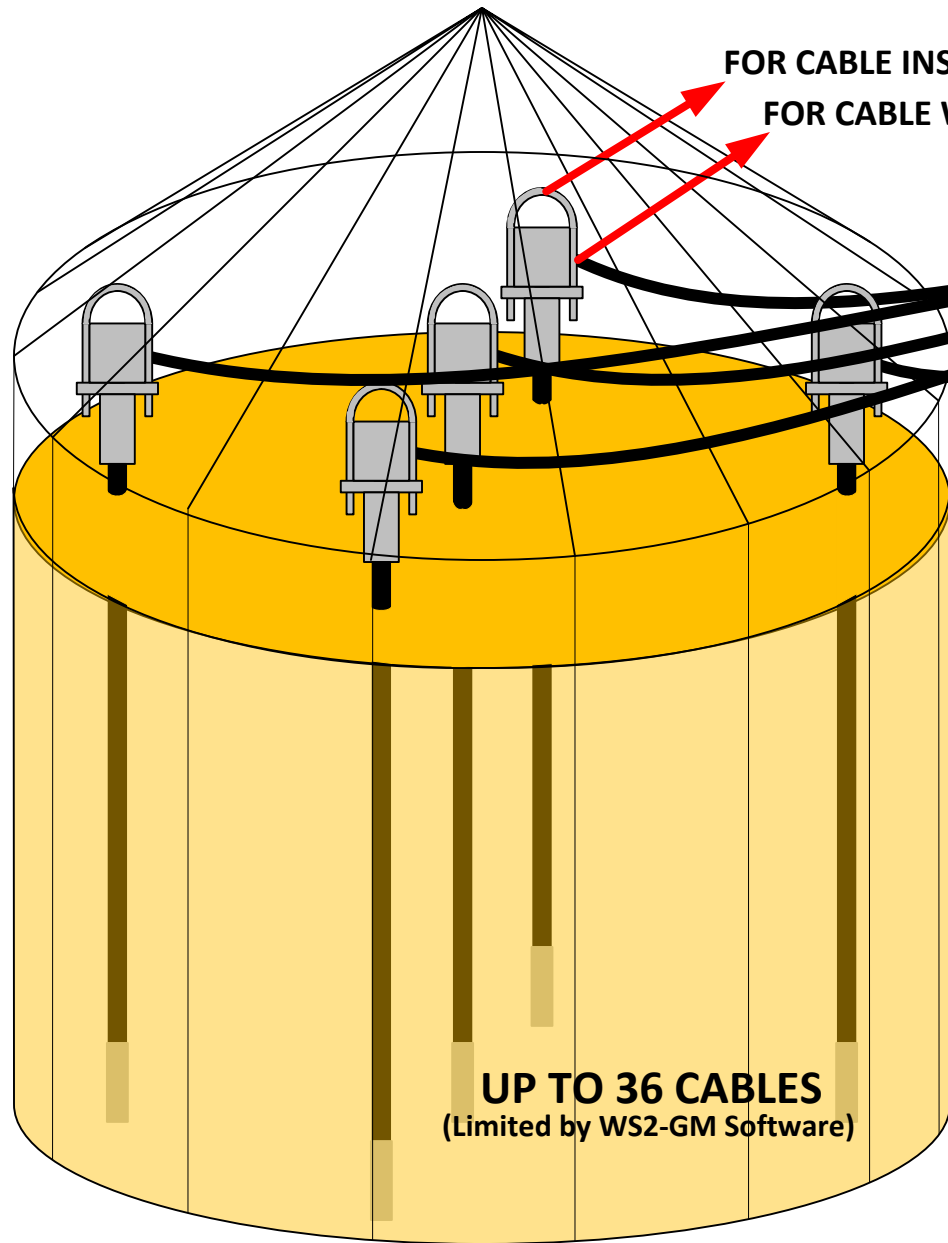

FOR CABLE INSTALLATION SEE PAGE 5 AND 6
FOR CABLE WIRING SEE PAGE 3

LEAD WIRE UP TO 1000 FT
20 AWG 2 COND CABLE
 (See page 3)

UP TO 36 CABLES
 (Limited by WS2-GM Software)

mDC002-5

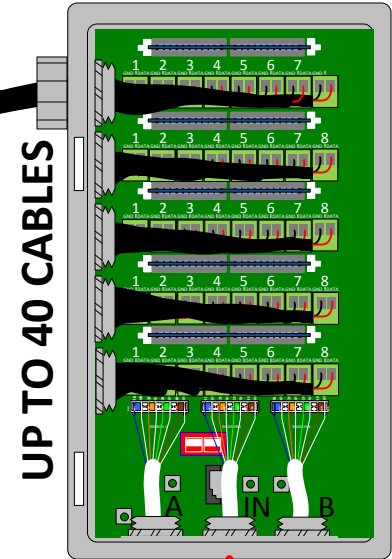

UP TO 40 CABLES

FOR INTERCONNECTION OVERVIEW
SEE PAGE 2

CMC CMC Industrial Electronics Ltd.
 Burnaby, BC Canada

GRAIN CABLE WIRING OVERVIEW

DO NOT SCALE	DRAWN BY: JP	REF: GRDC1/11999
DATE: APR 20/18	CHECKED BY: VB	DRAWING NO: 12049
COPYRIGHT 2018	APPROVED BY: VB	REV: A03
PAGE: 1 OF 11		

REV	DESCRIPTION	DATE	APP.

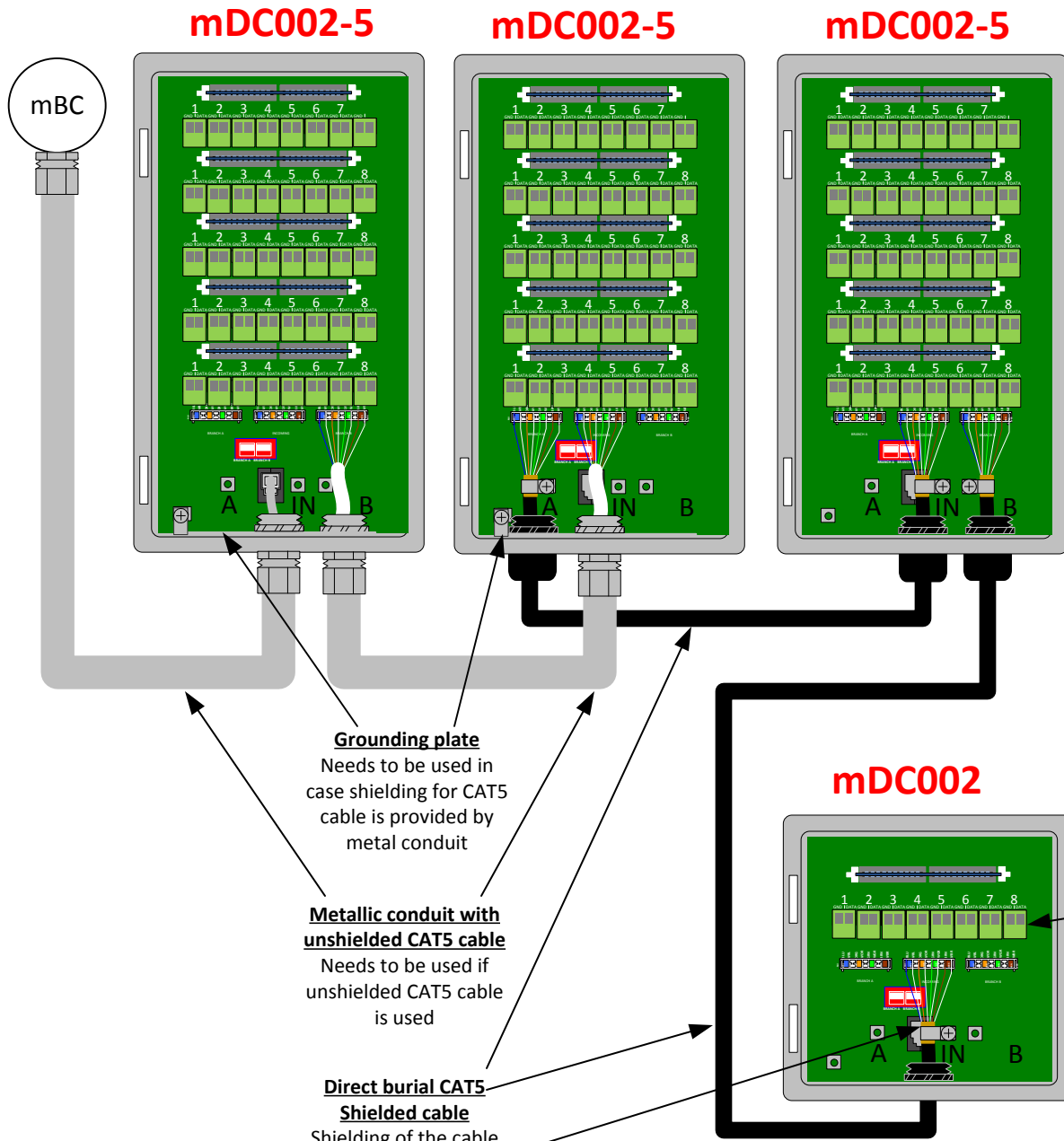

- Each Bus Converter can connect up to 16 mDC002 Controller Cards (16 on drawing)
- Each mDC002 can connect up to 8 Digital Grain Temp Cables
- Each mDC002-5 backplane can connect 5 mDC002 Controller Cards
- The length of CAT5 cable should not exceed 1000FT measured from the Bus Converter
- All CAT5 cables in the system need to be shielded
- If possible avoid T intersections (using both outgoing branches)

Grounding plate
Needs to be used in case shielding for CAT5 cable is provided by metal conduit

Metallic conduit with unshielded CAT5 cable
Needs to be used if unshielded CAT5 cable is used

Direct burial CAT5 Shielded cable
Shielding of the cable needs to be connected by clamp to the shielding standoff

FOR PROPER GROUNDING AND SHIELDING SEE PAGE 5

Lead Wire Connectors
Connectors for lead wires are supplied with the mDC002 cards installed in each slot

CMC CMC Industrial Electronics Ltd.
Burnaby, BC Canada

mDC002 WIRING OVERVIEW

DO NOT SCALE	DRAWN BY: JP	REF: GRDC1/11999	
DATE: APR 20/18	CHECKED BY: VB	DRAWING NO: 12049	REV: A03
COPYRIGHT 2018	APPROVED BY: VB	PAGE: 2 OF 11	

REV	DESCRIPTION	DATE	APP.

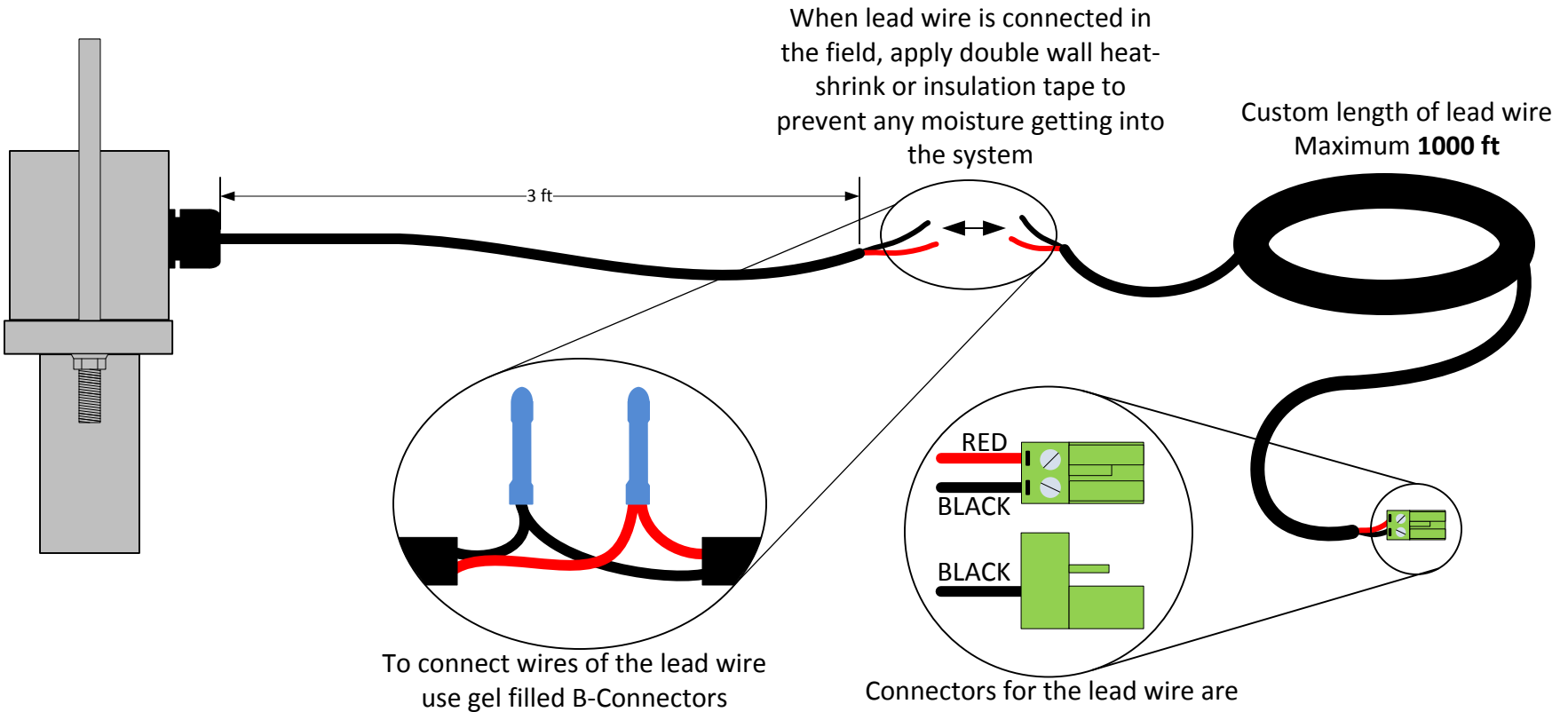

When lead wire is connected in the field, apply double wall heat-shrink or insulation tape to prevent any moisture getting into the system

Custom length of lead wire
Maximum **1000 ft**

To connect wires of the lead wire use gel filled B-Connectors

Connectors for the lead wire are supplied in the mDC002(1) backplane slots
(See page 2)

LEAD WIRE CABLE REFERENCE:		
CMC supplies cable TRC2002P (mfg. IEWC)		
<u>Specs:</u>		
AWG	-	20
No. of Conductors	-	2
Temp. Range	-	-40°C - 105°C

 CMC Industrial Electronics Ltd. Burnaby, BC Canada			
GRAIN CABLE LEAD WIRE CONNECTION			
DO NOT SCALE	DRAWN BY: JP	REF: GRDC1/11999	
DATE: APR 20/18	CHECKED BY: VB	DRAWING NO: 12049	REV: A03
COPYRIGHT 2018	APPROVED BY: VB	PAGE: 3 OF 11	

EZTESTER connection to:

- Configure GRDC cable (Cable format, Bin #, Cable #)
- Verification of cable configuration
- Temperature sensors reading

FOR MORE INFO SEE EZTESTER MANUAL

Sensor Configuration Mode



FW 2.31 or Higher

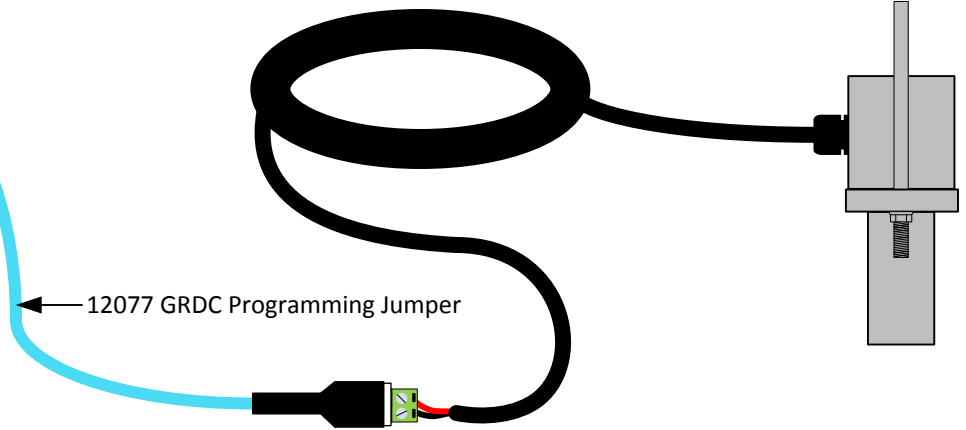

12077 GRDC Programming Jumper

REV	DESCRIPTION	DATE	APP.

EZTESTER connection to:

- Test mDC002 functionality
- Test GRDC Cable functionality
- Read temperature in connected sensors
- Read status of each connected cable

FOR MORE INFO SEE EZTESTER MANUAL

Sensor Test Mode



FW 2.33 or Higher

EZTester Modular Cable

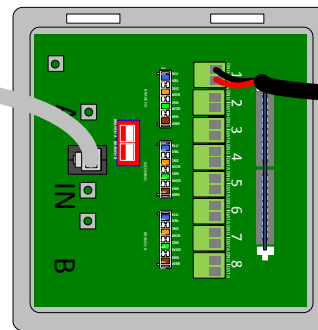

Max 1 Controller Card can be Connected

Up to 8 cables can be connected

CMC CMC Industrial Electronics Ltd.
Burnaby, BC Canada

mDC002 PARTS NAMING

DO NOT SCALE	DRAWN BY: JP	REF: GRDC1/11999
DATE: APR 20/18	CHECKED BY: VB	DRAWING NO: 12049
COPYRIGHT 2018	APPROVED BY: VB	REV: A03
PAGE: 4 OF 11		

REV	DESCRIPTION	DATE	APP.

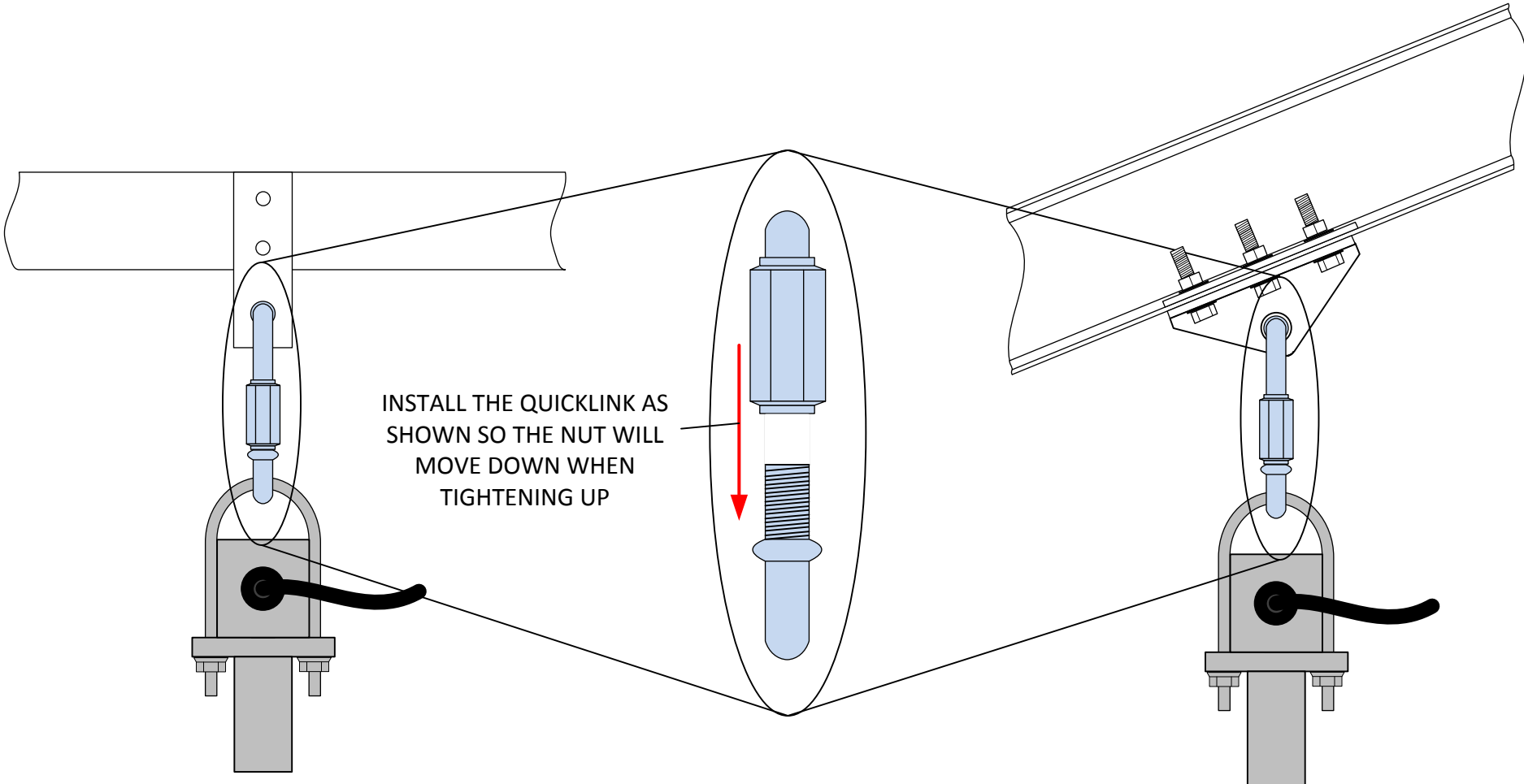

INSTALL THE QUICKLINK AS SHOWN SO THE NUT WILL MOVE DOWN WHEN TIGHTENING UP

FOR PROPER ISNTALLATION SEE ALSO MANUALS AND FOLLOW RECOMMENDATIONS OF THE BIN MANUFACTURER

CMC CMC Industrial Electronics Ltd.
Burnaby, BC Canada

**CABLE INSTALLATION
METAL BIN**

DO NOT SCALE	DRAWN BY: JP	REF: GRDC1/11999
DATE: APR 20/18	CHECKED BY: VB	DRAWING NO: 12049
COPYRIGHT 2018	APPROVED BY: VB	REV: A03
PAGE: 5 OF 11		

REV	DESCRIPTION	DATE	APP.

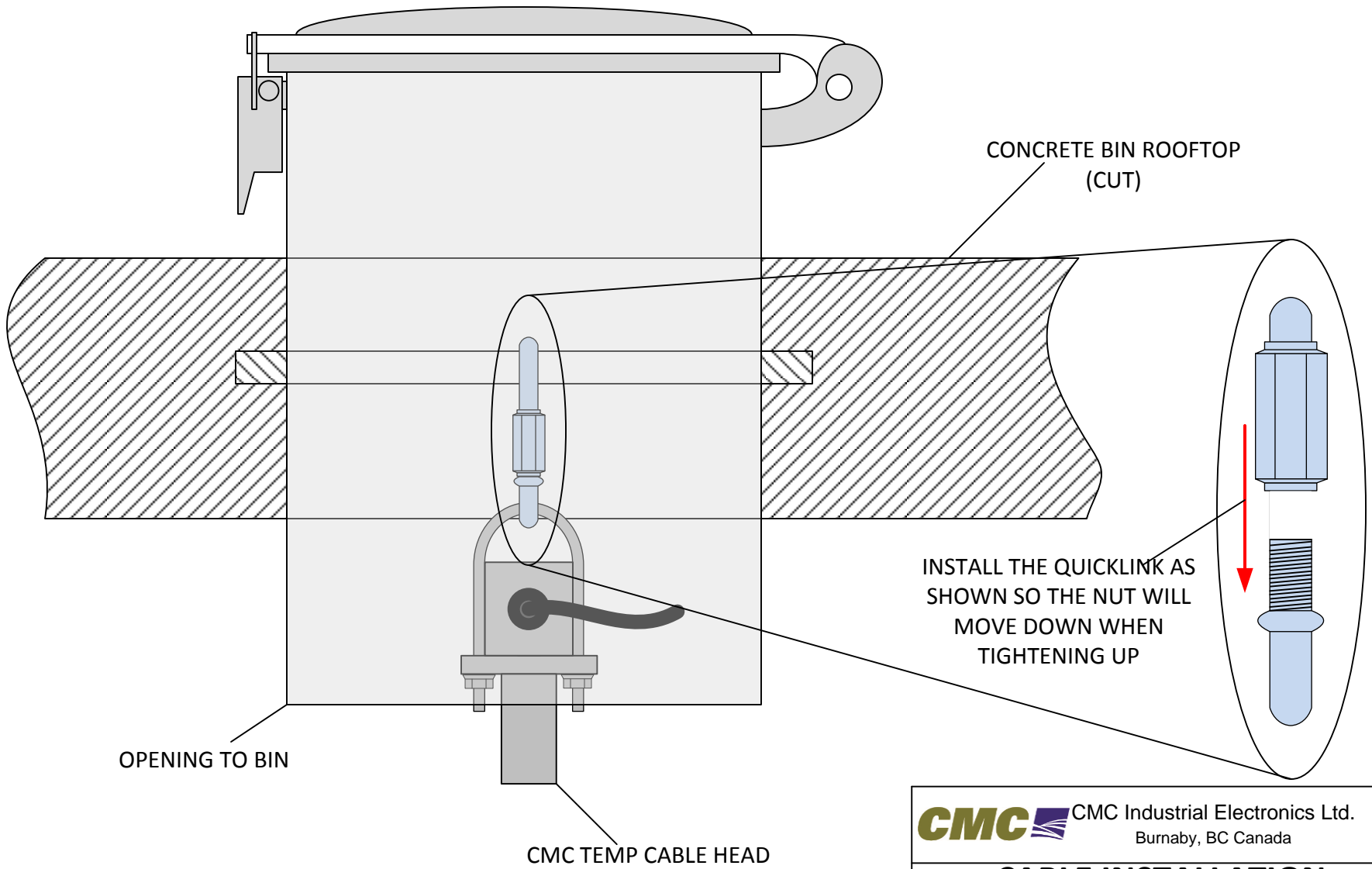

CMC CMC Industrial Electronics Ltd.
Burnaby, BC Canada

**CABLE INSTALLATION
CONCRETE BIN**

DO NOT SCALE	DRAWN BY: JP	REF: GRDC1/11999
DATE: APR 20/18	CHECKED BY: VB	DRAWING NO: 12049
COPYRIGHT 2018	APPROVED BY: VB	REV: A03
PAGE: 6 OF 11		

REV	DESCRIPTION	DATE	APP.

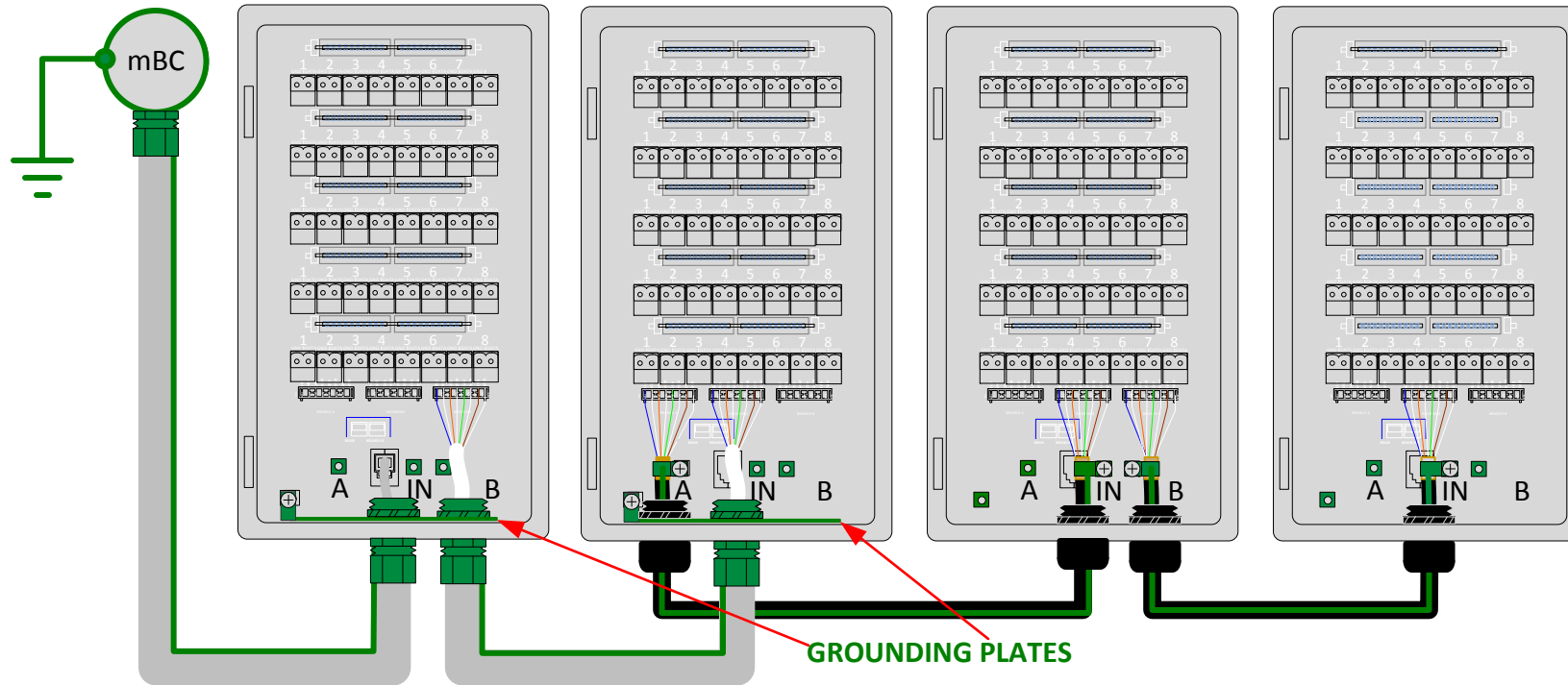

1. For correct functionality of the system it is very important that all CAT5 cables are properly shielded, and that the shielding is properly connected to an Earth ground of the facility at one point only
2. On this drawing is An Example of how the proper shielding might be achieved, parts colored green are parts which have a role in proper shielding
 - The Bus converter enclosure is connected to the Earth ground of the facility
 - The Bus converter enclosure is connected to metal conduit by a metal fitting
 - Metal conduit connects the second fitting, which is connected to the grounding plate of the first mDC002-5 backplane
 - The grounding plate is connected to the next metal fitting with metal conduit, which brings the Earth ground to the next mDC002-5 enclosure
 - The Earth ground is provided through the grounding plate of the second mDC002-5 connected to the mDC002 backplane shield standoffs where the first direct burial cable shield gets connected to the Earth ground
 - Direct burial cable connects to the mDC002-5 backplane shield standoffs and can be carried forward in the same fashion as described above

CMC CMC Industrial Electronics Ltd.
Burnaby, BC Canada

GROUNDING/SHIELDING

DO NOT SCALE	DRAWN BY: JP	REF: GRDC1/11999	
DATE: APR 20/18	CHECKED BY: VB	DRAWING NO: 12049	REV: A03
COPYRIGHT 2018	APPROVED BY: VB	PAGE: 7 OF 11	

REV	DESCRIPTION	DATE	APP.

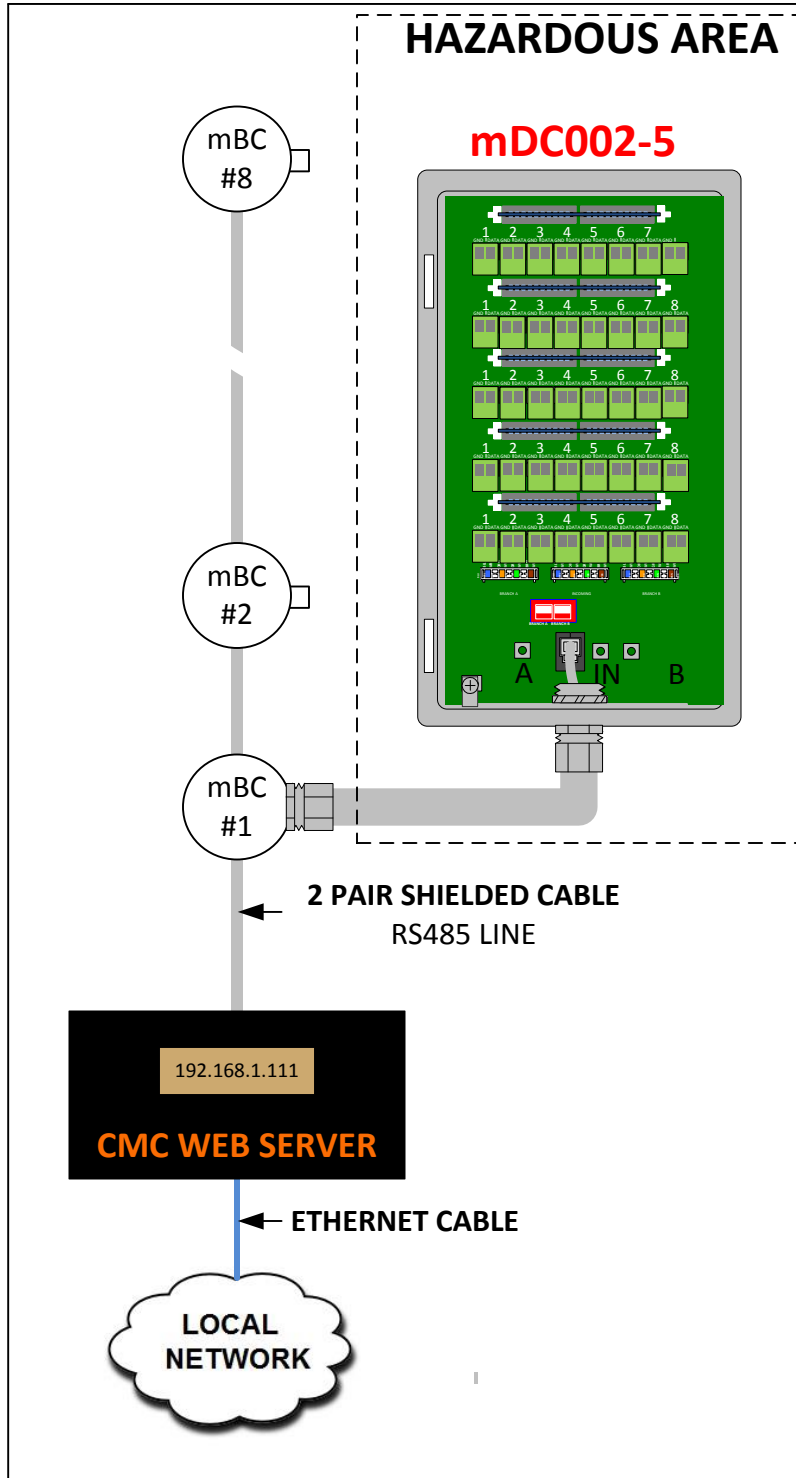

NOTES:

1. For detailed system installation see CMC drawing 11631 mBC083 Control Wiring Diagram and it's related documents.
2. For detailed connection of the web server see the web server manual
3. Up to 8 bus converters can be connected to the web server.
4. Each bus converter can connect up to 16 mDC002 Controller Cards.
5. Cable for RS-485 network should be 22 gauge for runs under 100', 20 gauge for runs under 200', 18 gauge for runs under 500' and 16 gauge for runs over 500'

Cable Reference Table for RS485 Line
Part numbers are for Tappan Wire cables

AWG	#COND	STR/SOLID	NOM. O.D	NOM. CAP. # PF/FT	UL LISTINGS	AVG. LBS PER MFT	SPEC #
22	4	STR	0.137	39.7	CMP/CL3P/F PLP	16	P20270.1
20	4	STR	0.151	43.7	CMP/CL3P/F PLP	22	P30003.1
18	4	STR	0.184	46.8	CMP/CL3P/F PLP	32	P40073.1
16	4	STR	0.21	52	CMP/CL3P/F PLP	47	P50023.1
14	4	STR	0.255	53.6	CL3P/FPLP	71	P60024.1

CMC CMC Industrial Electronics Ltd.
Burnaby, BC Canada

GRDC1 & mDC002 & WS2
WIRING OVERVIEW

DO NOT SCALE	DRAWN BY: JP	REF: GRDC1/11999	
DATE: APR 20/18	CHECKED BY: VB	DRAWING NO: 12049	REV: A03
COPYRIGHT 2018	APPROVED BY: VB	PAGE: 8 OF 11	

REV	DESCRIPTION	DATE	APP.

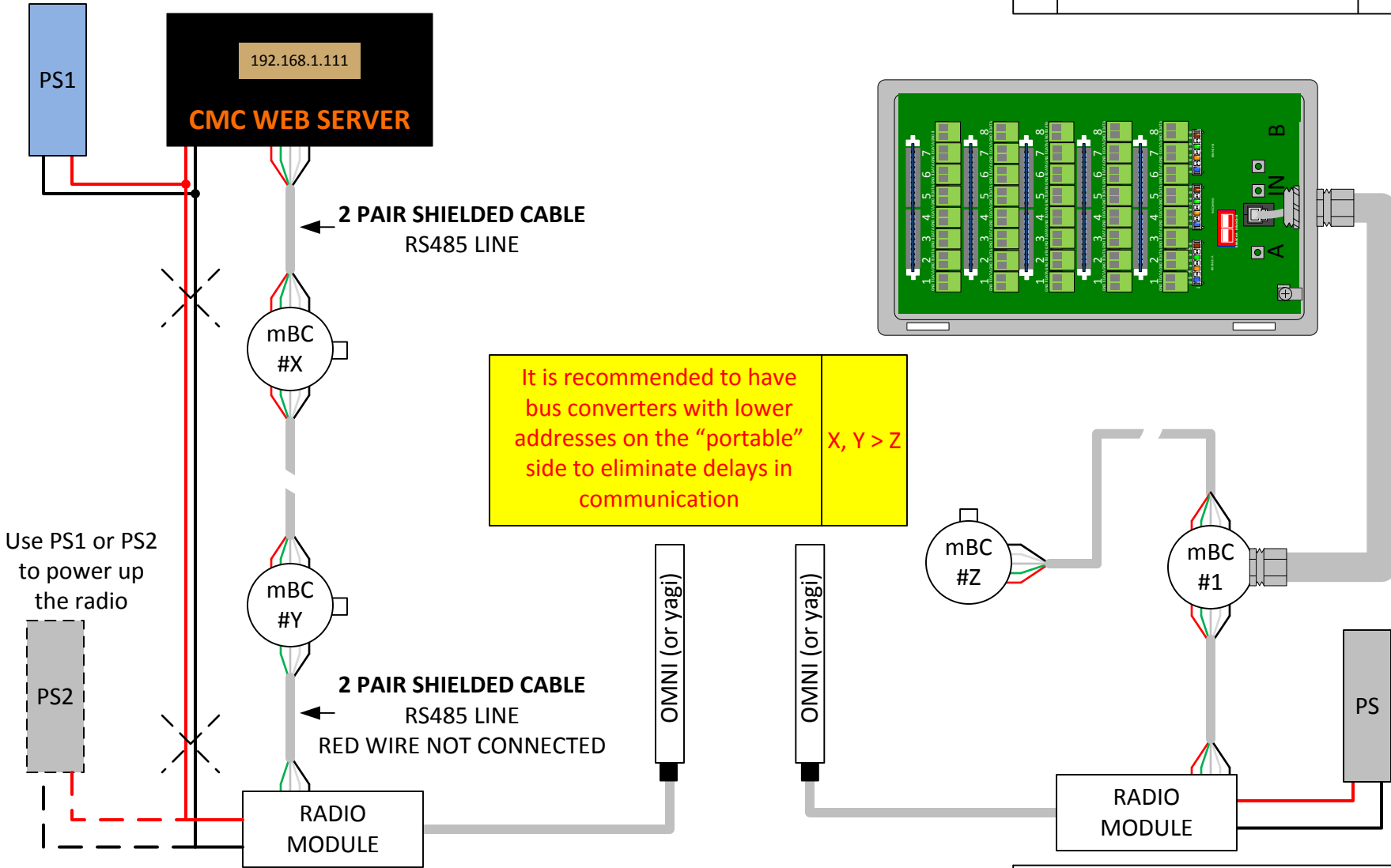

It is recommended to have bus converters with lower addresses on the "portable" side to eliminate delays in communication X, Y > Z

Use PS1 or PS2 to power up the radio



It is not recommended to power up the radios through the WS2 Modbus 24 VDC. This power source is dedicated for bus converters only and has limited current which can be supplied. This limitation is easily exceeded by power consumption of the radio. Therefore separated power supply (as drawn) for radios is recommended.

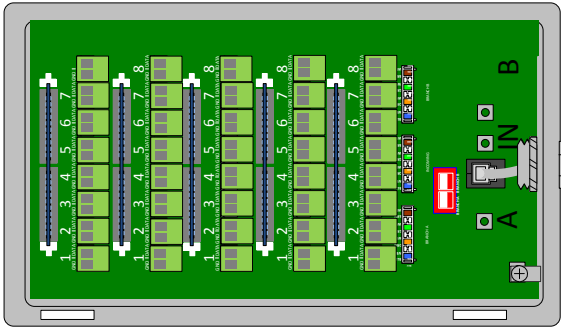

CMC CMC Industrial Electronics Ltd.
Burnaby, BC Canada

Radio Connection Overview

DO NOT SCALE	DRAWN BY: JP	REF: GRDC1/11999	
DATE: APR 20/18	CHECKED BY: VB	DRAWING NO: 12049	REV: A03
COPYRIGHT 2018	APPROVED BY: VB	PAGE: 9 OF 11	

REV	DESCRIPTION	DATE	APP.

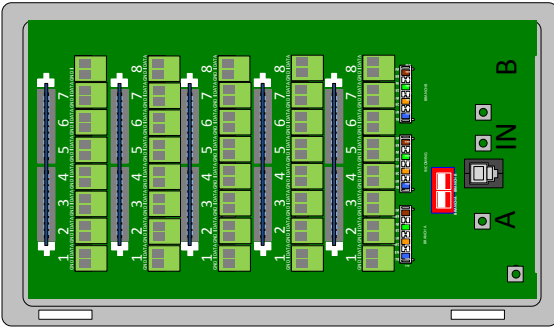

mDC002-5

Multi-card assembly with 5 controller cards, 40 connectors and enclosure

Same naming convention for -4, -3, -2, -1

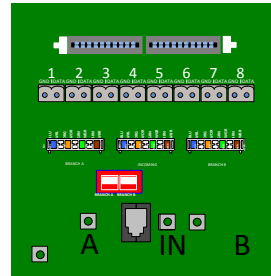

mDC002-BP

Single-card backplane

No controller card, no connectors, no enclosure

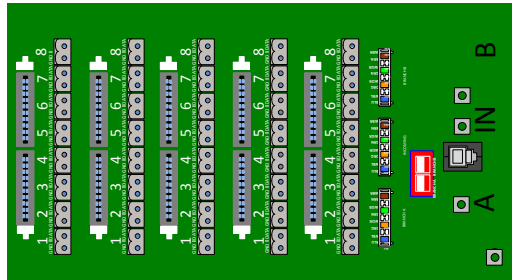

mDC002-5-BP

Multi-card backplane

No controller card, no connectors, no enclosure

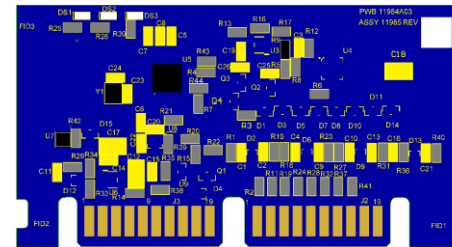

mDC002-CC

Controller Card

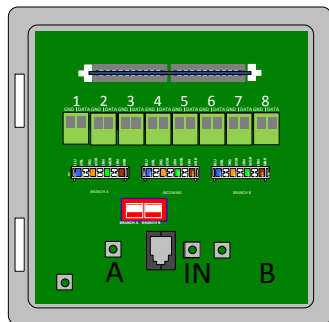

mDC002

Single-card assembly with 1 controller cards, 8 connectors and enclosure

12077

GRDC Programming Jumper



CMC CMC Industrial Electronics Ltd.
Burnaby, BC Canada

mDC002 PARTS NAMING

DO NOT SCALE	DRAWN BY: JP	REF: GRDC1/11999	
DATE: APR 20/18	CHECKED BY: VB	DRAWING NO: 12049	REV: A03
COPYRIGHT 2018	APPROVED BY: VB	PAGE: 10 OF 11	

!!!OPI Cable must be configured into CMC format by EZTester to work with mDC002 controller card!!!

REV	DESCRIPTION	DATE	APP.

EZTester Sensors Representation

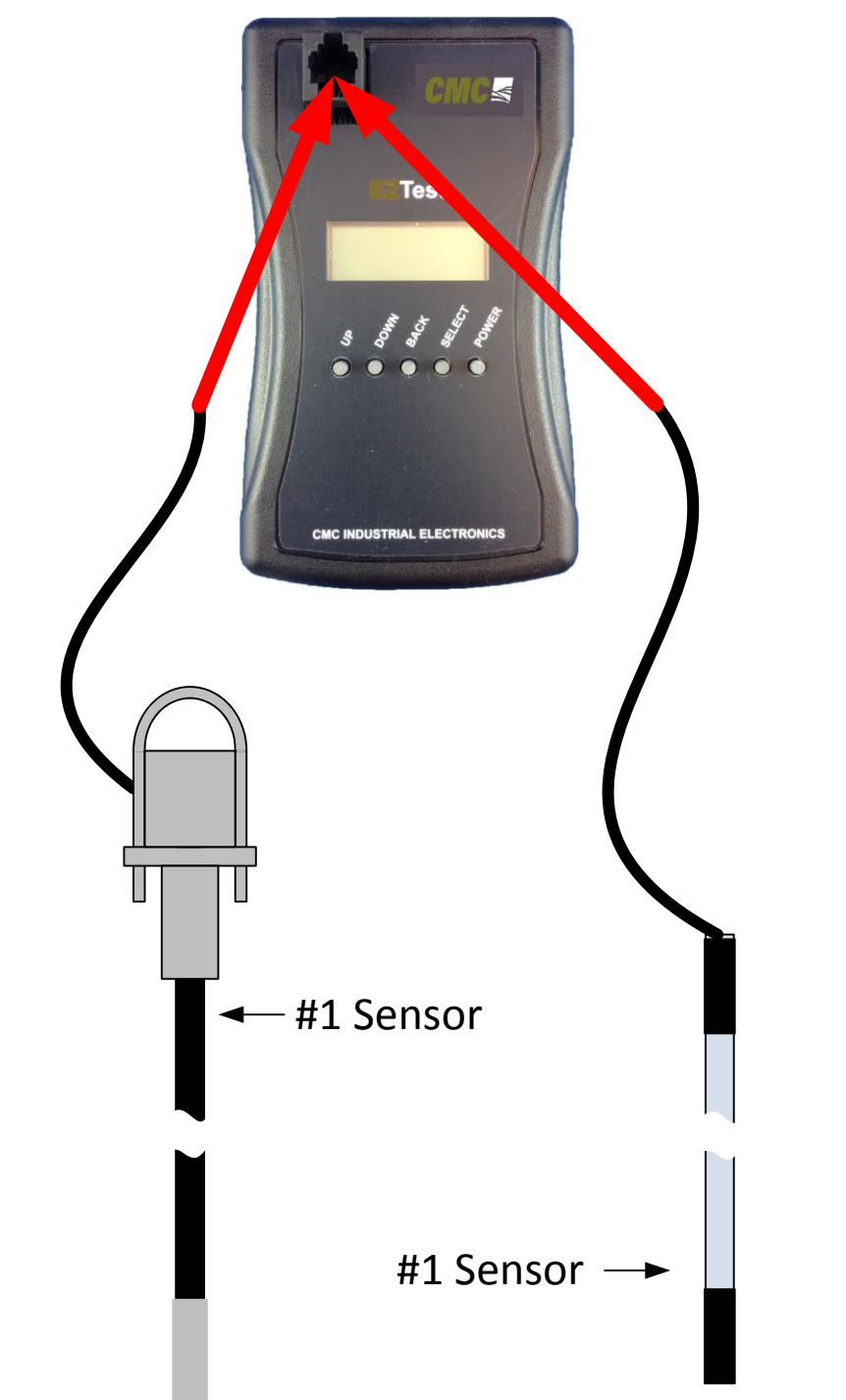

CMC CABLE **OPI CABLE**
 Sensor #1 will be read at these positions when read by EZTester

mDC002

FW 1.10 and higher

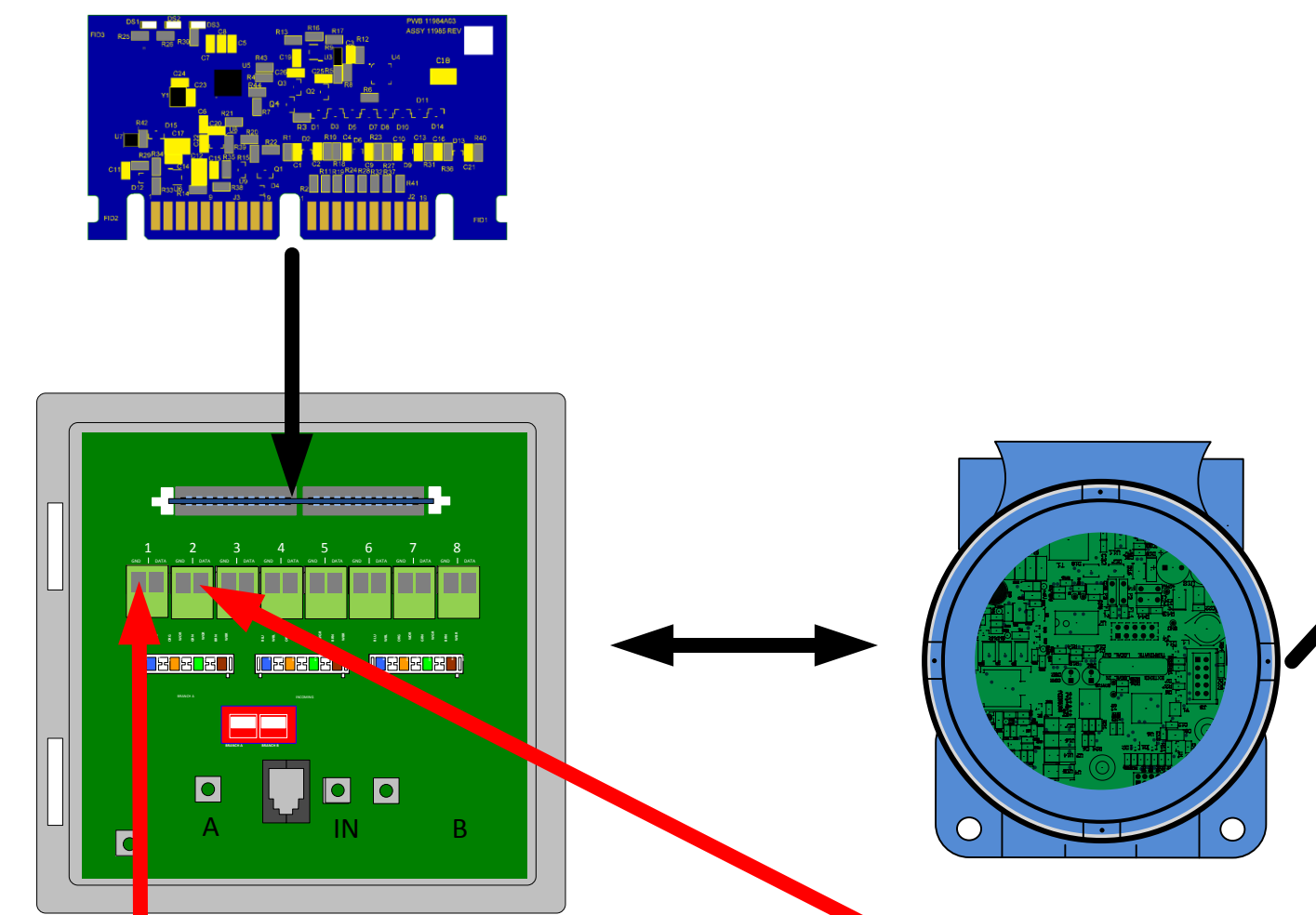

Sensors or controller cards acquired by bus converter

mBC Table Position	DATA
1	Sensor or controller card assigned to the first position of bus converter table
...	...
8	Example of the position where the presented mDC002 card would be assigned
...	...
32	Sensor or controller card assigned to the last position of bus converter table

Representation of data provided by mDC002 multiplexed on assigned bus converter position

FOR DETAILED DESCRIPTION SEE MANUAL FOR MDC002

ADDRESS	DATA
0	mDC002 Card Status
1	mDC002 Card Ambient Temperature
2	Plug 1 - CMC Cable Sensor #1
...	...
22	Plug 1 - CMC Cable Sensor #21
...	...
30	Plug 2 - OPI Cable Sensor #1
...	...
50	Plug 2 - OPI Cable Sensor #21
...	...

mDC002 will represent sensor #1 at the top of the cable on both CMC and OPI cable

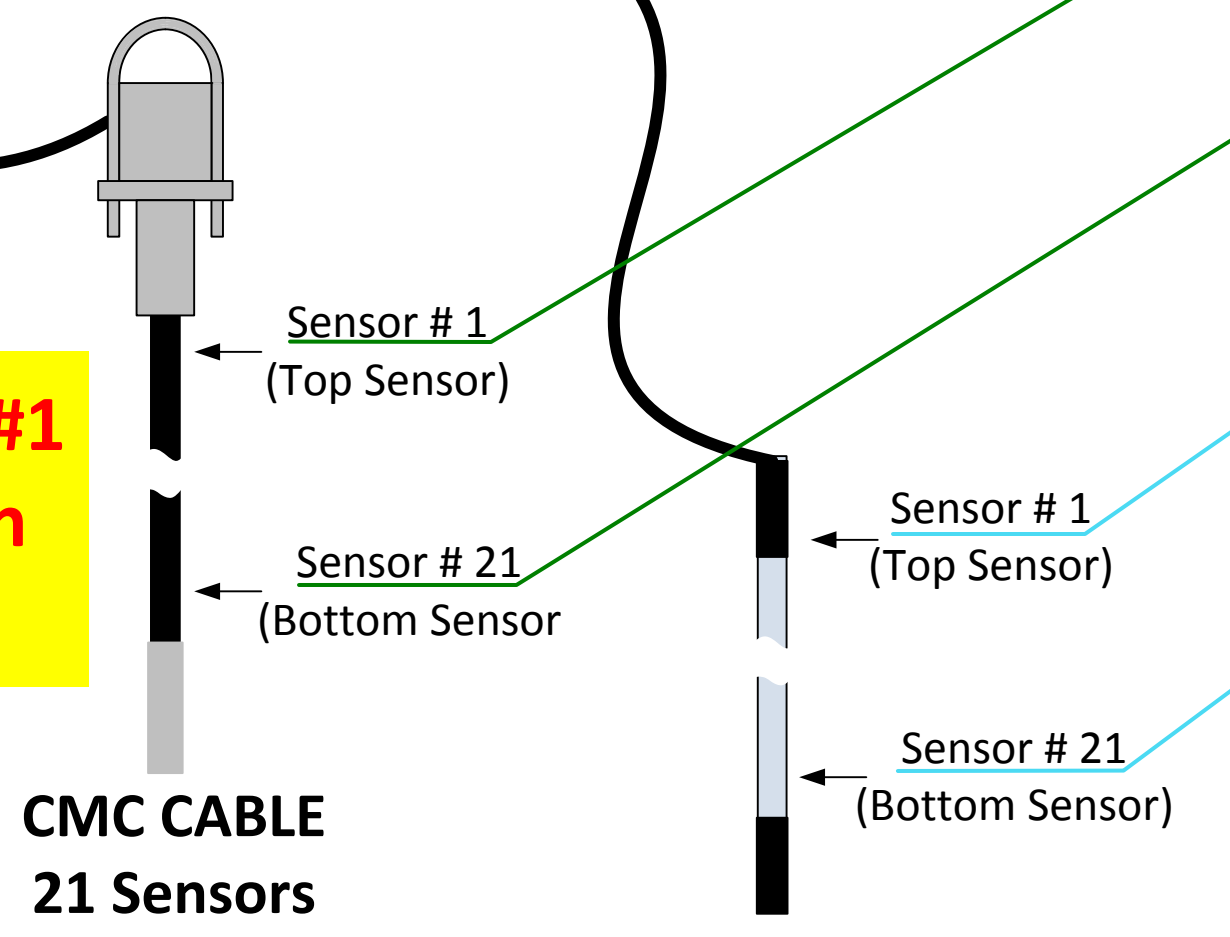

CMC CABLE
21 Sensors

OPI CABLE
21 Sensors

Same representation will be if the data are read directly from the bus converter, if the data are read on Modbus through mOI215 and when read as raw Modbus data through WS2-GM