



S-Drive Standard Conveyor

Portable Grain Belt Conveyor Operator's Manual

This manual applies to the following models:

1500 Series: 1565, 1575, 1585, 1590, 15100

2000 Series: 2065, 2075, 2085, 2095, 20105, 20110, 20120

2400 Series: 2465, 2475, 2485, 2495, 24105, 24110, 24120

Gas, Electric, and PTO Drives

Original Instructions



Read this manual before using product. Failure to follow instructions and safety precautions can result in serious injury, death, or property damage. Keep manual for future reference.

Part Number: P1512123 R7

Revised: November 2018

CONTENTS

1. Introduction	5
1.1. Serial Number Location.....	5
1.2. Intended Use	5
1.2.1 Misuse	6
2. Safety.....	7
2.1. Safety Alert Symbol and Signal Words.....	7
2.2. General Product Safety	7
2.3. Overhead Power Lines	8
2.4. Moving Conveyor Belt Safety.....	8
2.5. Upending	8
2.6. Rotating Parts Safety.....	8
2.7. Work Area Safety	8
2.8. Guards Safety	10
2.9. Raising and Lowering the Conveyor.....	11
2.10. Positioning the Conveyor	11
2.11. Towing the Conveyor	11
2.12. Drives and Lockout Safety.....	12
2.12.1 Gas Engine Safety.....	12
2.12.2 Electric Motor Safety.....	13
2.12.3 PTO Driveline Safety.....	13
2.12.4 Hydraulic Power Safety	14
2.13. Tire Safety.....	15
2.14. Battery Safety	15
2.15. Personal Protective Equipment.....	16
2.16. Safety Equipment	16
2.17. Safety Decals	17
2.17.1 Decal Installation/Replacement.....	17
2.17.2 Safety Decal Locations and Details	17
3. Features.....	33
3.1. Model Number	34
4. Transport.....	35
4.1. Transport Safety	35
4.2. Transport Preparation	35
4.3. Connect the Conveyor to the Towing Vehicle	36
5. Placement	37
5.1. Placement Safety.....	37
5.2. Positioning the Conveyor	37
5.3. Extendable Axle Positioning.....	38
5.4. Positioning the Conveyor with a Wheel Move Kit.....	39
5.5. Raising and Lowering	41
5.6. Collapsible Hopper Cloth.....	42
5.7. Conveyor Operating Angles	43
6. Operation	45
6.1. Operation Safety	45
6.2. Start-up and Break-in	45

6.3. Operation - Electric Motor Models	46
6.4. Operation - Gas Engine Models	46
6.5. Operation - PTO Drive	46
6.6. Loading Area	47
6.7. Conveyor Belt Speed	47
6.8. Emergency Shutdown	48
6.9. Restarting with a Full Tube	48
6.10. Shutdown	48
6.11. Clean Out	48
6.12. Conveying Fertilizer	49
6.13. Storage	50
7. Maintenance	52
7.1. Maintenance Safety	52
7.2. Maintenance Schedule	52
7.3. Visually Inspect the Equipment	53
7.4. Lubricate the Equipment	54
7.4.1 PTO Driveline	54
7.5. Check the Gearbox Oil	54
7.6. Change the Gearbox Oil	55
7.7. Inspect Hydraulic Hoses and Fittings	55
7.8. Inspect the Hopper Flashing	55
7.9. Check the Roller Bearings	55
7.10. Check the Roller Lagging	56
7.11. Tension the Conveyor Belt	56
7.11.1 S-Drive Pinch Roller	57
7.12. Align the Conveyor Belt	58
7.12.1 Adjust the Rollers	59
7.12.2 Adjust the Belt Return Wear Blocks	59
7.13. Inspect Belt Lacing	60
7.14. Replace the Belt Lacing	60
7.15. Replace the Conveyor Belt	60
7.16. Clean and Wash the Equipment	62
7.17. Tension the Drive Belts	62
7.18. Align the Drive Belts	63
7.19. Replace the Drive Belts	63
7.20. Repack the Wheel Bearings with Grease	63
7.21. Check/Adjust the Truss Cables	64
7.22. Pinion Gear Adjustment	66
8. Troubleshooting	67
9. Specifications	71
10. AGI Swift Current Limited Warranty	73

1. Introduction

Thank you for purchasing a Batco Portable Grain Belt Conveyor. This equipment will allow safe and efficient operation when you read and follow all of the instructions contained in this manual. With proper care, your conveyor will provide you with many years of trouble-free operation.

Keep this manual handy for frequent reference and to review with new personnel. A sign-off form is provided on the inside front cover for your convenience. If any information in this manual is not understood or if you need additional information, please contact your local distributor or dealer for assistance.

This manual should be regarded as part of the equipment. Suppliers of both new and second-hand equipment are advised to retain documentary evidence that this manual was provided with the equipment.

1.1. Serial Number Location

Always give your dealer the serial number on your conveyor (shown below) when ordering parts or requesting service or other information. Please record this information in the table below for easy reference.

Model Number	
Serial Number	
Date Received	

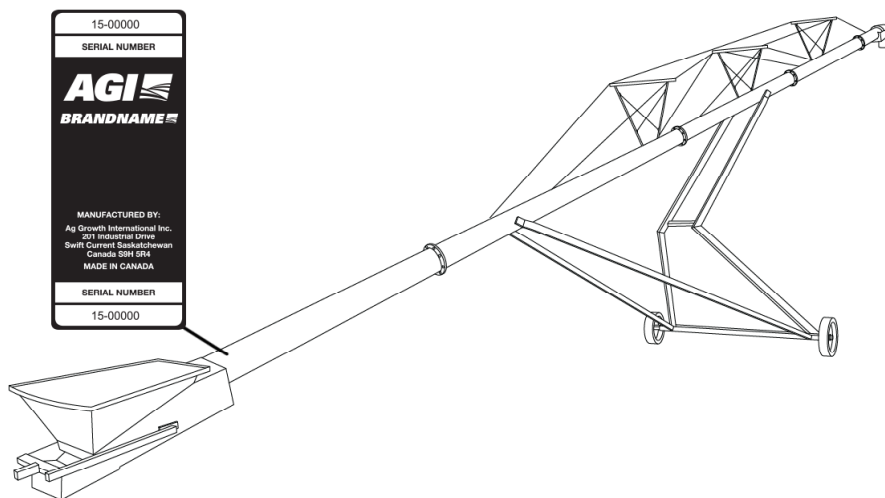

1.2. Intended Use

The conveyor is designed solely for use in the intended agricultural use as listed below. Use in any other way is considered as contrary to the intended use. Compliance with and strict adherence to the conditions of operation and maintenance as specified by the manufacturer, also constitute essential elements of the intended use.

The conveyor should be operated, maintained, serviced, and repaired only by persons who are familiar with its particular characteristics and who are acquainted with the relevant safety procedures.

Accident prevention regulations and all other generally recognized regulations on occupational health and safety must be observed at all times.

Any modifications made to the conveyor may relieve the manufacturer of liability for any resulting damage or injury.

Intended use for the conveyor:

- Handling grain, pulse crops, treated seeds, or other similar materials.
- Handling fertilizer when strict operation and cleanout procedures are followed as noted in Operation section.

Use in any other way is considered as contrary to the intended use and is not covered by the warranty.

1.2.1 Misuse

Do not use the conveyor for/with:

- transferring material other than dry, free-flowing food-grains.
- conveying canola, or any other oilseeds
- lifting or using as a hoist or crane.

2. Safety

2.1. Safety Alert Symbol and Signal Words



This safety alert symbol indicates important safety messages in this manual. When you see this symbol, be alert to the possibility of injury or death, carefully read the message that follows, and inform others.

Signal Words: Note the use of the signal words **DANGER**, **WARNING**, **CAUTION**, and **NOTICE** with the safety messages. The appropriate signal word for each message has been selected using the definitions below as a guideline.



DANGER Indicates an imminently hazardous situation that, if not avoided, will result in serious injury or death.



WARNING Indicates a hazardous situation that, if not avoided, could result in serious injury or death.



CAUTION Indicates a hazardous situation that, if not avoided, may result in minor or moderate injury.



NOTICE Indicates a potentially hazardous situation that, if not avoided, may result in property damage.

2.2. General Product Safety

YOU are responsible for the **SAFE** use and maintenance of your conveyor. **YOU** must ensure that you and anyone else who is going to work around the conveyor understands all procedures and related **SAFETY** information contained in this manual.

Remember, **YOU** are the key to safety. Good safety practices not only protect you, but also the people around you. Make these practices a working part of your safety program. All accidents can be avoided.

- It is the conveyor owner, operator, and maintenance personnel's responsibility to read and understand **ALL** safety instructions, safety decals, and manuals and follow them when operating, or maintaining the equipment.
- Owners must give instructions and review the information initially and annually with all personnel before allowing them to operate the conveyor. Untrained users/operators expose themselves and bystanders to possible serious injury or death.
- The conveyor is not intended to be used by children.
- Use the conveyor for its intended purposes only.
- Do not modify the conveyor in any way without written permission from the manufacturer. Unauthorized modification may impair the function and/or safety, and could affect the life of the conveyor. Any unauthorized modification will void the warranty.



2.3. Overhead Power Lines

DANGER

- When operating or moving, keep conveyor away from overhead power lines and devices.
- The conveyor is not insulated.
- Electrocutation can occur without direct contact.



2.4. Moving Conveyor Belt Safety

WARNING

- DO NOT step on or touch moving conveyor belt.
- Shut off and lock out power to adjust, service, or clean.



2.5. Upending

WARNING

- Anchor intake end and/or support discharge end to prevent upending.
- Intake end must always have downward weight. Do not release until attached to tow bar or resting on ground.
- Do not raise intake end above tow bar height.
- Empty the conveyor and fully lower before moving.

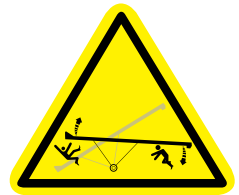

2.6. Rotating Parts Safety

WARNING

- Keep body, hair, and clothing away from rotating pulleys, belts, chains, and sprockets.
- Do not operate with any guard removed or modified. Keep guards in good working order.
- Shut off and remove key or lock out power source before inspecting or servicing machine.



2.7. Work Area Safety

WARNING

- Have another trained person nearby who can shut down the conveyor in case of accident.
- The work area should be kept clear of bystanders.
- Keep the work area clean and free of debris.

Figure 1. Conveyor Work Area (Gas/Electric Drive)

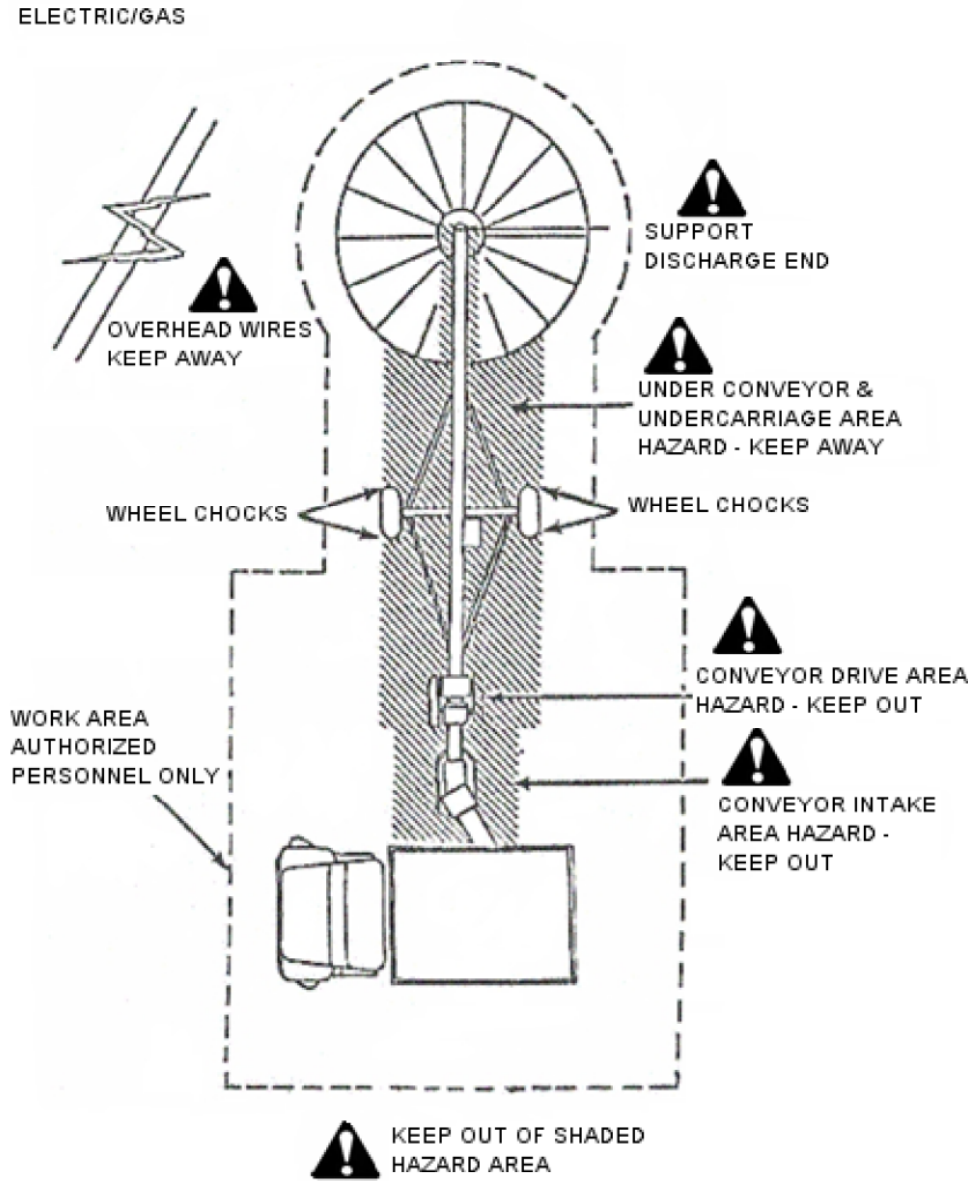
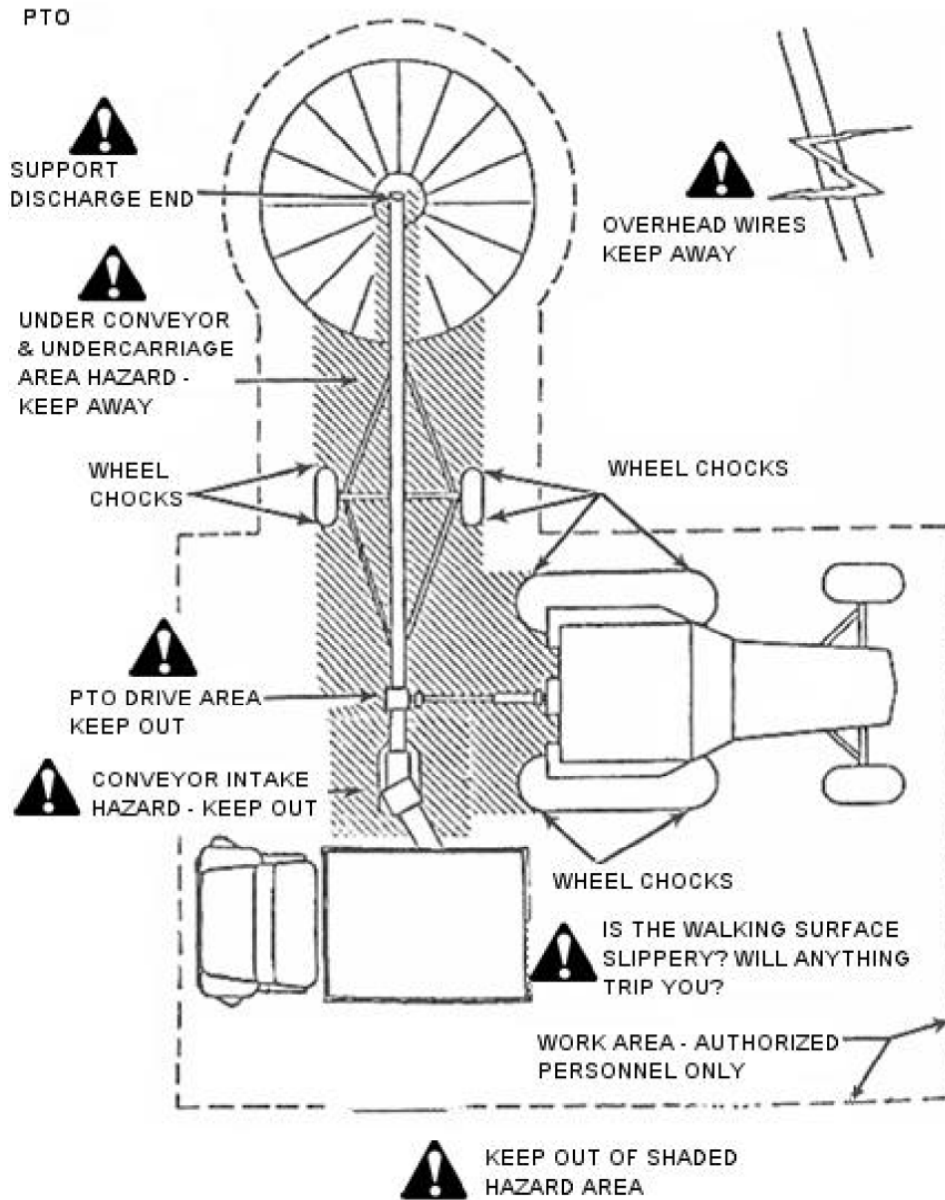

Figure 2. Conveyor Work Area (PTO Drive)



2.8. Guards Safety

- ⚠ WARNING**
- Keep guards in place and do not operate unless all guards are in place.
 - Do not walk on, step on, or damage guards.
 - Lock out power before removing a guard.
 - Ensure all guards are replaced after performing maintenance.

2.9. Raising and Lowering the Conveyor

- ⚠ WARNING**
- Before raising/lowering/moving/adjusting the conveyor, make sure the area around the conveyor is clear of obstructions and/or untrained personnel. Never allow anyone to stand on or beneath the conveyor when it is being placed.
 - Lower the conveyor to its lowest position when not in use.
 - Empty the conveyor before raising or lowering.
 - Do not get on or beneath the conveyor when raising or lowering.
 - Raise and lower conveyor on reasonably level ground only.
 - Never attempt to increase height of the tube by positioning wheels on lumber, blocks, or by any other means. To do so will result in damage to conveyor and/or serious injury.
 - Do not raise the conveyor in high winds.

2.10. Positioning the Conveyor

- ⚠ WARNING**
- Transport and place equipment on reasonably level ground when raising, lowering, positioning, or operating.
 - Move the conveyor into position slowly. Do not unhitch and attempt to move by hand.
 - Chock wheels and anchor intake end after placement.

2.11. Towing the Conveyor

The conveyor is not intended for transport on public roads. If it requires transport on a public roadway, the following steps should be taken:

- ⚠ WARNING**
- Check with local authorities regarding transport on public roads. Obey all applicable laws and regulations.
 - Always travel at a safe speed, never exceeding 20 mph (32 km/h).
 - Reduce speed on rough surfaces.
 - Do not transport on slopes greater than 20°.
 - Use caution when turning corners or meeting traffic.
 - Make sure the SMV (slow moving vehicle) emblem and all the lights and reflectors that are required by local authorities are in place, are clean, and can be seen by all over-taking and oncoming traffic.
 - Always use hazard-warning flashers on tractor/towing vehicle when transporting unless prohibited by law.
 - Do not allow riders on the conveyor or towing vehicle during transport.
 - Attach to towing vehicle with an appropriate pin and retainer. Always attach safety chains.
 - Place the conveyor in the transport position before moving on roads.



2.12. Drives and Lockout Safety

Inspect the power source(s) before using and know how to shut down in an emergency. Whenever you service or adjust your equipment, make sure you shut down the power source and unplug or remove the key (as applicable) to prevent inadvertent start-up and hazardous energy release. Know the procedure(s) that applies to your equipment from the following power source(s). Ensure that all personnel are clear before turning on power to equipment.

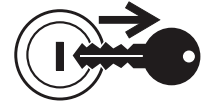

2.12.1 Gas Engine Safety

⚠ WARNING Power Source

- Keep guards in place and secure.
- Properly ventilate surrounding area.
- Never fill the fuel tank with the engine running, while smoking, or near an open flame. Always shut down and allow engine to cool before filling with fuel.
- Never overfill the tank or spill fuel. If fuel is spilled, clean it up immediately.
- Be sure to use the correct type and grade of fuel. Ground the fuel funnel or nozzle against the filler neck to prevent sparks that could ignite fuel vapors.
- Be sure to replace the fuel fill cap when you are done.



Lockout

- For engines with an electric start, remove the ignition key, the spark plug wire, or the spark plug.
- For engines with a rope or crank start, remove the spark plug wire or the spark plug.

2.12.2 Electric Motor Safety

WARNING Power Source

- Electric motors and controls shall be installed and serviced by a qualified electrician and must meet all local codes and standards.
- A magnetic starter should be used to protect your motor.
- You must have a manual reset button.
- Reset and motor starting controls must be located so that the operator has full view of the entire operation.
- Locate main power disconnect switch within reach from ground level to permit ready access in case of an emergency.
- Motor must be properly grounded.
- Guards must be in place and secure.
- Ensure electrical wiring and cords remain in good condition; replace if necessary.
- Use a totally enclosed electric motor if operating in extremely dusty conditions.

Lockout

- The main power disconnect switch should be in the locked position during shutdown or whenever maintenance is performed.
- If reset is required, disconnect all power **before** resetting motor.

SERVICE DISCONNECT

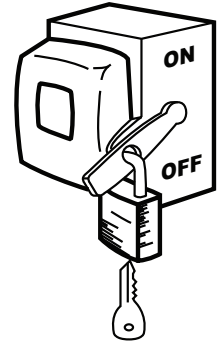

2.12.3 PTO Driveline Safety

WARNING Drive

- Keep body, hair, and clothing away from rotating PTO driveline.
- Make certain the driveline shields telescope and rotate freely on driveline before attaching.
- Make certain the driveline is securely attached at both ends.
- Do not operate conveyor unless all driveline, tractor, and equipment shields are in place and in good working order.
- Do not exceed the specified operating speed.
- Keep universal joint angles small and equal. Do not exceed maximum recommended length for PTO driveline.
- Engage tractor park brake and/or chock wheels.

Lockout

- Position all controls in neutral, shut off tractor's engine, and remove key from tractor.
- If removing key is impossible, remove PTO driveline from tractor.



2.12.4 Hydraulic Power Safety

WARNING Power Source

- Refer to the rules and regulations applicable to the power source operating your hydraulic drive.
- Do not connect or disconnect hydraulic lines while system is under pressure.
- Keep all hydraulic lines away from moving parts and pinch points.
- Escaping hydraulic fluid under pressure will cause serious injury if it penetrates the skin surface (serious infection or toxic reaction can develop). See a doctor immediately if injured.
- Use metal or wood as a backstop when searching for hydraulic leaks and wear proper hand and eye protection.
- Check all hydraulic components are tight and in good condition. Replace any worn, cut, abraded, flattened, or crimped hoses.
- Clean the connections before connecting to equipment.
- Do not attempt any makeshift repairs to the hydraulic fittings or hoses with tape, clamps, or adhesive. The hydraulic system operates under extremely high pressure; such repairs will fail suddenly and create a hazardous and unsafe condition.

Lockout

- Always place all hydraulic controls in neutral and relieve system pressure before disconnecting or working on hydraulic system.



2.13. Tire Safety

WARNING Failure to follow proper procedures when mounting a tire on a wheel or rim can produce an explosion that may result in serious injury or death.



- DO NOT attempt to mount a tire unless you have the proper equipment and experience to do the job.
- Have a qualified tire dealer or repair service perform required tire maintenance.
- When replacing worn tires, make sure they meet the original tire specifications. Never undersize the replacement tire.
- DO NOT weld to the tire rim with the tire mounted on the rim. This action may cause an explosion which could result in serious injury or death.
- Inflate tires to the manufacturer's recommended pressure.
- Tires should not be operated at speeds higher than their rated speed.
- Keep wheel lug nuts tightened to manufacturer's recommendations.
- Never reinflate a tire that has been run flat or seriously under-inflated without removing the tire from the wheel. Have the tire and wheel closely inspected for damage before remounting.

2.14. Battery Safety

- WARNING**
- Wear safety glasses and protective gloves when working near batteries.
 - Make certain the battery or terminal covers are in place and in good working order.
 - Keep all sparks and flames away from batteries; gas given off by electrolyte is explosive.
 - Avoid contact with battery electrolyte. Wash off any spilled electrolyte immediately.
 - Do not tip batteries more than 45° to avoid electrolyte loss.
 - To avoid injury from sparks or short circuits, disconnect battery ground cable before servicing any part of an electrical system.



2.15. Personal Protective Equipment

The following Personal Protective Equipment (PPE) should be worn when operating or maintaining the equipment.

Safety Glasses

- Wear safety glasses at all times to protect eyes from debris.



Coveralls

- Wear coveralls to protect skin.



Hard Hat

- Wear a hard hat to help protect your head.



Steel-Toe Boots

- Wear steel-toe boots to protect feet from falling debris.



Work Gloves

- Wear work gloves to protect your hands from sharp and rough edges.



Dust Mask

- Wear a dust mask to prevent breathing potentially harmful dust.



2.16. Safety Equipment

The following safety equipment should be kept on site:

Fire Extinguisher

- Provide a fire extinguisher for use in case of an accident. Store in a highly visible and accessible place.



First-Aid Kit

- Have a properly-stocked first-aid kit available for use should the need arise, and know how to use it.



2.17. Safety Decals

- Keep safety decals clean and legible at all times.
- Replace safety decals that are missing or have become illegible. See decal location figures that follow.
- Replaced parts must display the same decal(s) as the original part.
- Replacement safety decals are available **free of charge** from your distributor, dealer, or factory as applicable.

2.17.1 Decal Installation/Replacement

1. Decal area must be clean and dry, with a temperature above 50°F (10°C).
2. Decide on the exact position before you remove the backing paper.
3. Align the decal over the specified area and carefully press the small portion with the exposed sticky backing in place.
4. Slowly peel back the remaining paper and carefully smooth the remaining portion of the decal in place.
5. Small air pockets can be pierced with a pin and smoothed out using the sign backing paper.

2.17.2 Safety Decal Locations and Details

Replicas of the safety decals that are attached to the conveyor and their messages are shown in the figure(s) that follow. Safe operation and use of the conveyor requires that you familiarize yourself with the various safety decals and the areas or particular functions that the decals apply to, as well as the safety precautions that must be taken to avoid serious injury, death, or damage.



Figure 3. Scissor-Lift Conveyor Safety Decal Locations

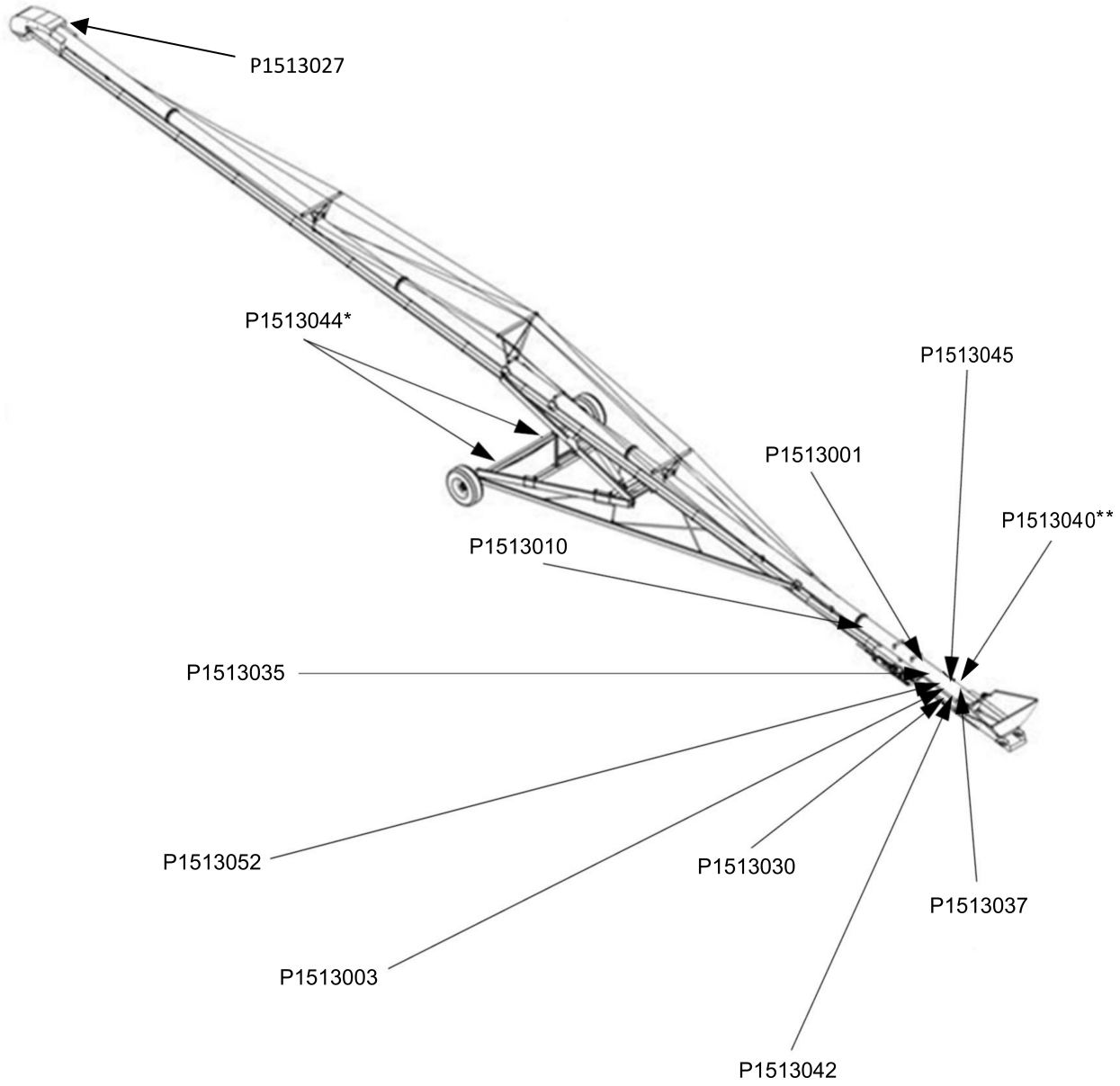

* if equipped with retractable axles

** if equipped with Mover Kit

Figure 4. S-Drive Safety Decal Locations

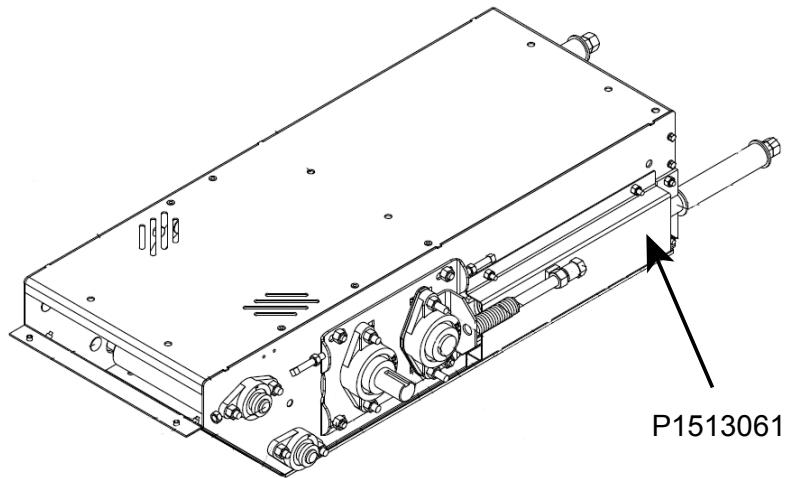

Figure 5. Gas Drive Safety Decal Locations

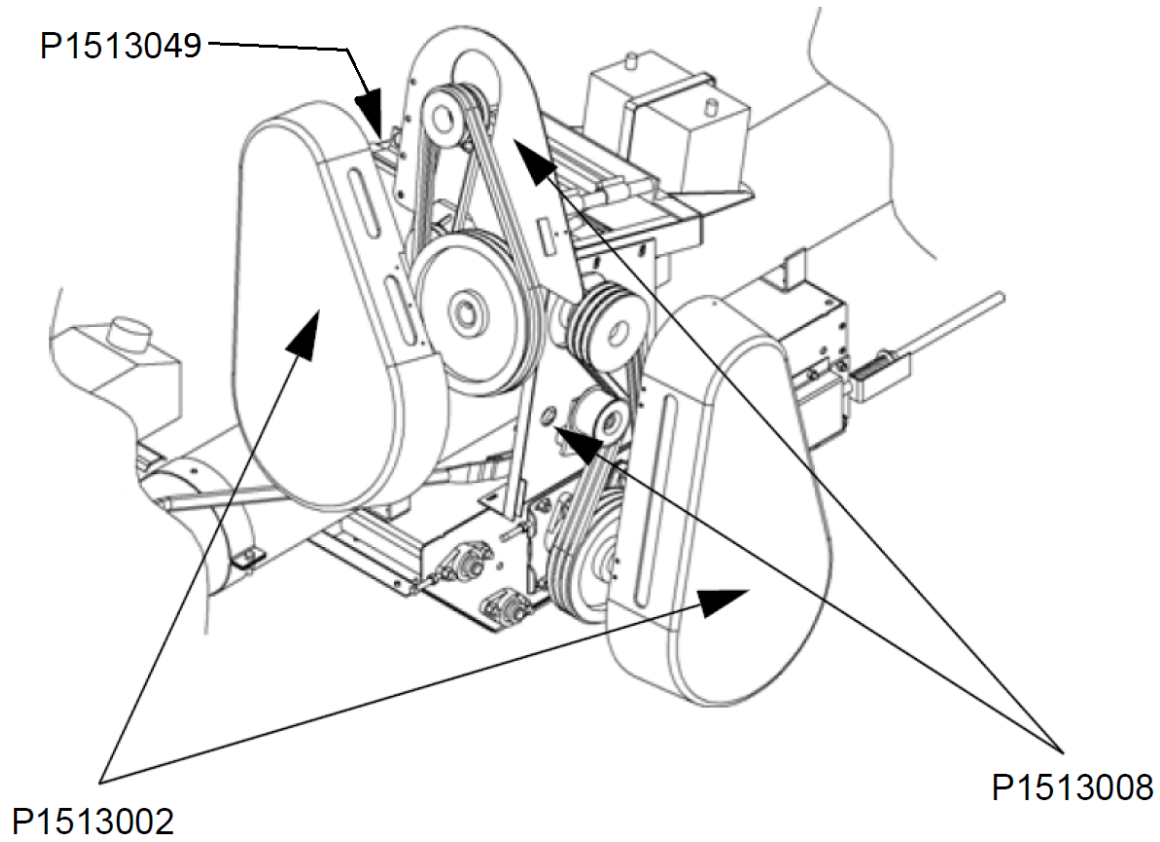

Figure 6. Electric Drive Safety Decal Locations

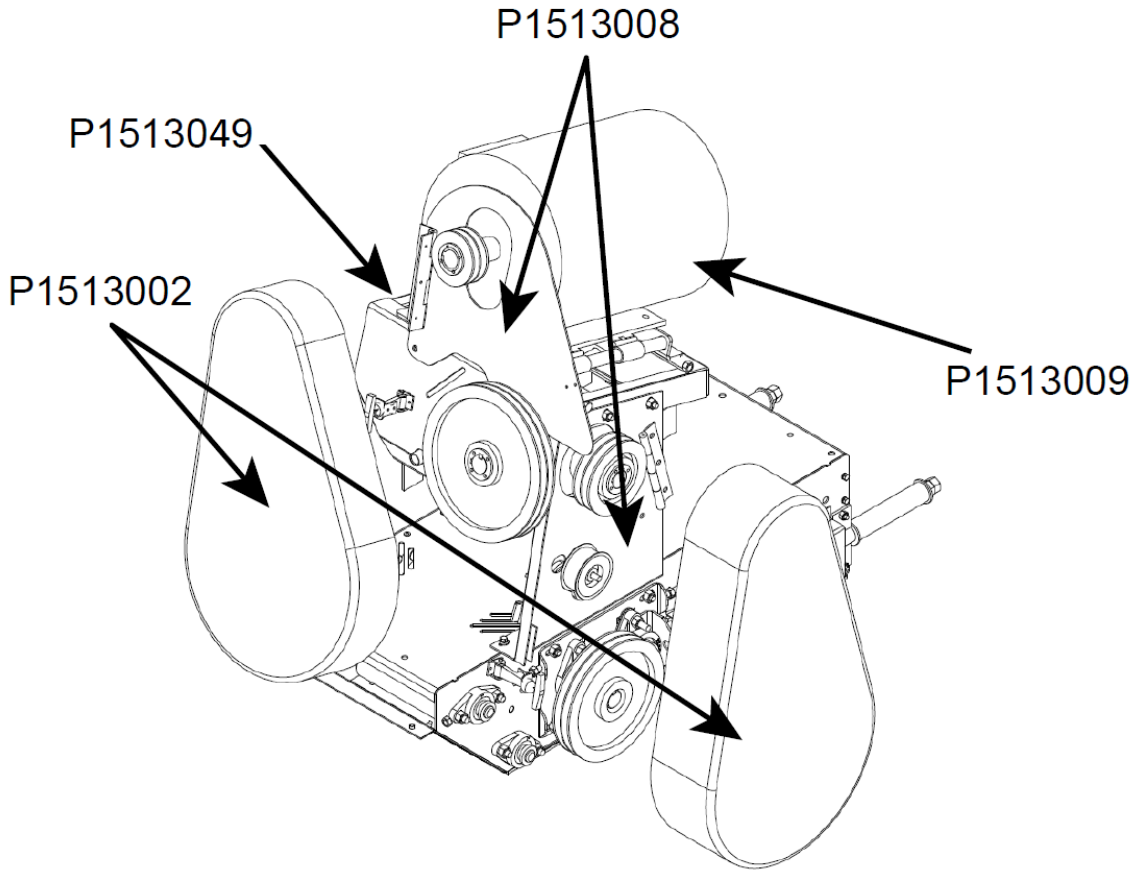

Figure 7. Side PTO Drive Safety Decal Locations

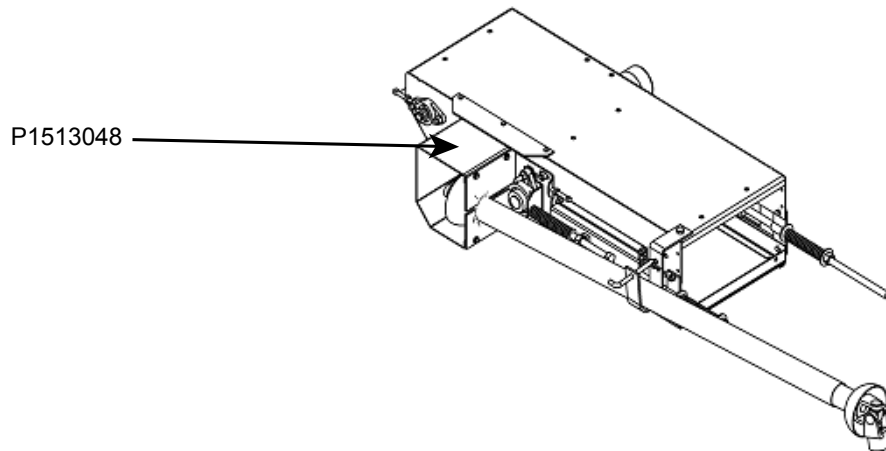

Figure 8. Front PTO Drive Safety Decal Locations

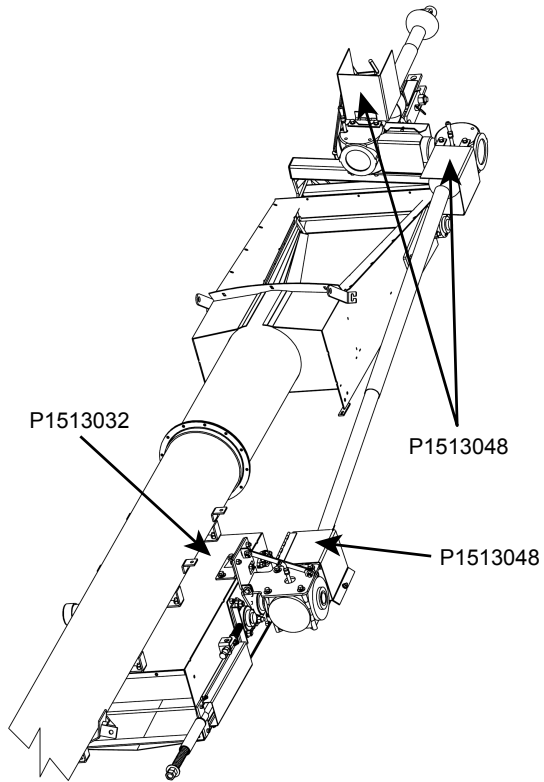

Figure 9. Wheel Move Kit for S-Drive Standard Conveyor (1500-Series) — Decal Locations



Table 1. Safety Decals



Part Number	Description
P1513003	<div style="border: 1px solid black; padding: 10px;"> <div style="background-color: red; color: white; text-align: center; padding: 5px;"> DANGER </div> <div style="display: flex; justify-content: space-around; align-items: center; margin-top: 10px;">   </div> <div style="text-align: center; margin-top: 10px;"> <p>ELECTROCUTION HAZARD</p> <p>To prevent death or serious injury:</p> <ul style="list-style-type: none"> When operating or moving, keep equipment away from overhead power lines and devices. Fully lower equipment before moving. <p>This equipment is not insulated.</p> <p>Electrocution can occur without direct contact.</p> </div> </div>
P1513048	<div style="border: 1px solid black; padding: 10px;"> <div style="display: flex; justify-content: space-between; align-items: center;"> <div style="width: 30%;">   </div> <div style="width: 65%;"> <div style="background-color: red; color: white; text-align: center; padding: 5px;"> DANGER </div> <div style="text-align: center; margin-top: 5px;"> <p>ROTATING PTO DRIVELINE HAZARD</p> </div> <p>To prevent serious injury or death:</p> <ul style="list-style-type: none"> Keep body, hair, and clothing away from rotating PTO driveline. Do not operate equipment unless all driveline, tractor, and equipment shields are in place and in good working order. Make certain the driveline shields turn freely on driveline. Make certain the driveline is securely attached at both ends. Do not exceed specified operating speed (see operator's manual). Keep u-joint angles small and equal. Do not exceed maximum recommended length for PTO driveline. </div> </div> </div>



Table 1 Safety Decals (continued)

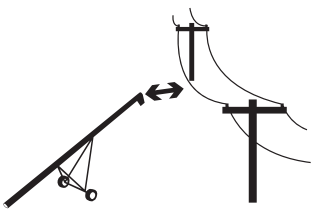

Part Number	Description
P1513001	<div style="border: 2px solid black; padding: 10px;"> <div style="background-color: #f4a460; padding: 5px; text-align: center; border: 1px solid black;">  WARNING </div> <div style="display: flex; justify-content: space-around; margin-top: 10px;"> <div style="text-align: center;">  </div> <div style="text-align: center;">  </div> </div> <div style="margin-top: 10px;"> <p>To prevent serious injury or death:</p> <ul style="list-style-type: none"> • Read and understand the manual before assembling, operating, or maintaining the equipment. • Only trained personnel may assemble, operate, or maintain the equipment. • Children and untrained personnel must be kept outside of the work area. • Do not modify the equipment. Keep in good working order. • If the manual, guards, or decals are missing or damaged, contact factory or dealer for replacements. • Lock out power before performing maintenance. • To prevent equipment collapse, support equipment tube while disassembling certain components. • Electric motors must be grounded. Disconnect power before resetting overloads. </div> </div>

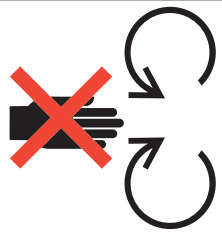
Table 1 Safety Decals (continued)



Part Number	Description
P1513002	<div style="border: 2px solid black; padding: 10px;"> <div style="background-color: #f4a460; text-align: center; padding: 5px;"> WARNING</div> <div style="display: flex; justify-content: space-around; align-items: center; margin-top: 10px;">   </div> <div style="text-align: center; margin-top: 10px;">ENTANGLEMENT HAZARD</div> <p>To prevent serious injury or death:</p> <ul style="list-style-type: none"> • Keep body, hair, and clothing away from rotating pulleys, belts, chains, and sprockets. • Do not operate with any guard removed or modified. Keep guards in good working order. • Shut off and remove key or lock out power source before inspecting or servicing machine. </div>
P1513008	<div style="border: 2px solid black; padding: 10px;"> <div style="background-color: #f4a460; text-align: center; padding: 5px;"> WARNING</div> <div style="display: flex; justify-content: space-between; align-items: center; margin-top: 10px;"> <div style="text-align: center;">   </div> <div style="margin-left: 20px;"> <p>MISSING GUARD HAZARD</p> <p>To prevent serious injury or death, shut off power and reattach guard before operating machine.</p> </div> </div> </div>



Table 1 Safety Decals (continued)







Part Number	Description
P1513009	<div style="border: 1px solid black; padding: 10px;"> <div style="display: flex; justify-content: space-between; align-items: center;"> <div style="text-align: center;">   </div> <div style="text-align: center;">  <p>WARNING</p> <p>ELECTROCUTION HAZARD</p> <p>To prevent serious injury or death:</p> <ul style="list-style-type: none"> • Only qualified personnel should service electrical components. • Disconnect and lockout power before inspecting or servicing unit. • Keep electrical components in good repair. </div> </div> </div>
P1513035	<div style="border: 1px solid black; padding: 10px;"> <div style="text-align: center; background-color: #f4a460; padding: 5px;">  <p>WARNING</p> </div> <div style="display: flex; justify-content: space-around; align-items: center; margin-top: 10px;"> <div style="text-align: center;">  </div> <div style="text-align: center;">  </div> </div> <div style="margin-top: 10px;"> <p>HIGH PRESSURE FLUID HAZARD</p> <p>Hydraulic fluid can cause serious injury if it penetrates the skin. If it does, see a doctor immediately.</p> <ul style="list-style-type: none"> • Relieve system pressure before repairing, adjusting or disconnecting. • Wear proper hand and eye protection when searching for leaks. Use wood or cardboard instead of hands. </div> </div>

Table 1 Safety Decals (continued)









Part Number	Description
P1513045	<div style="border: 1px solid black; padding: 10px;"> <div style="background-color: #f4a460; padding: 5px; text-align: center;">  WARNING </div> <div style="display: flex; justify-content: space-around; align-items: center; margin: 10px 0;">   </div> <div style="text-align: center;"> <p>OPEN BELT CONVEYOR</p> <p>To prevent death or serious injury:</p> <ul style="list-style-type: none"> • DO NOT step on or touch moving conveyor belt. • Shut off and lock out power to adjust, service, or clean. </div> </div>
P1513044	<div style="border: 1px solid black; padding: 10px;"> <div style="display: flex; justify-content: space-between; align-items: center;"> <div style="text-align: center;">  </div> <div style="text-align: center;">  </div> <div style="background-color: #f4a460; padding: 5px; text-align: center;">  WARNING </div> </div> <div style="text-align: center; margin: 10px 0;"> <p>ROLLOVER / TRANSPORT HAZARD</p> <p>To prevent serious injury or death:</p> <ul style="list-style-type: none"> • Fully extend axles before raising tube. • Retract axles before transporting. </div> </div>
P1513042	<div style="border: 1px solid black; padding: 10px;"> <div style="display: flex; justify-content: space-between; align-items: center;"> <div style="text-align: center;">  </div> <div style="background-color: #f4a460; padding: 5px; text-align: center;">  WARNING </div> </div> <div style="text-align: center; margin: 10px 0;"> <p>UPENDING HAZARD</p> <p>To prevent death or serious injury:</p> <ul style="list-style-type: none"> • Anchor intake end and/or support discharge end to prevent upending. • Intake end must always have downward weight. Do not release until attached to tow bar or resting on ground. • Do not raise intake end above tow bar height. • Empty conveyor and fully lower before moving. </div> </div>



Table 1 Safety Decals (continued)

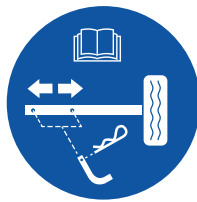



Part Number	Description
P1513036	<div style="display: flex; align-items: center;">   <div style="margin-left: 20px;"> <p style="text-align: center;"> WARNING</p> <p style="text-align: center;">HIGH PRESSURE FLUID HAZARD</p> <p>Hydraulic fluid can cause serious injury if it penetrates the skin. If it does, see a doctor immediately.</p> <ul style="list-style-type: none"> • Relieve system pressure before repairing, adjusting or disconnecting. • Wear proper hand and eye protection when searching for leaks. Use wood or cardboard instead of hands. </div> </div>
P1513040	<div style="text-align: center;"> <p> WARNING</p> <p>TRANSPORT HAZARD</p> <p>To prevent serious injury or equipment damage, before towing:</p> <ul style="list-style-type: none"> • Lift up wheel frame completely and secure with safety chain. • Pull handle to disengage drive wheel motors. </div>
P1513010	<div style="text-align: center;"> <p> CAUTION</p> <p>To prevent personal injury or damage to equipment, close valve in lift cylinder hydraulic line after raising equipment into position.</p> </div>

Table 1 Safety Decals (continued)

Part Number	Description
P1513030	 <p>NOT A STEP - SLIP HAZARD To prevent injury or damage to the equipment, do not use belt guard as a step.</p>
P1513061	 <p>NOTICE</p> <p>To prevent belt damage, use correct belt tension and do not attempt to adjust belt tracking with the take-up roller.</p> <p>To set correct belt tension:</p> <ul style="list-style-type: none"> • While conveyor is running empty, tighten nut against the pretensioner (take-up pipe) so that the edge of the indicator pipe is within the green area. • Ensure take-up roller is tensioned equally by using a tape to measure distance "X". • After the conveyor belt has been tensioned, check the alignment of all other s-drive rollers and periodically afterward. <p>See manual for complete instructions.</p>



Table 1 Safety Decals (continued)

Part Number	Description
P1513027	<div style="border: 2px solid black; padding: 10px;"> <div style="background-color: #0056b3; color: white; text-align: center; padding: 5px; font-weight: bold; font-size: 1.5em;">NOTICE</div> <div style="text-align: center; margin: 10px 0;">  <p>The diagram shows a V-shaped roller with an arrow pointing downwards from the top center, labeled "Belt Direction".</p> </div> <p>To prevent damage to the belt and roller:</p> <ul style="list-style-type: none"> • Install roller with roller lagging pointing in the direction of belt travel. • Annually inspect condition of roller, lagging and belt. • Ensure that you do not run a machine with loose lagging, or the conveyor belt may become damaged. </div>

Table 1 Safety Decals (continued)

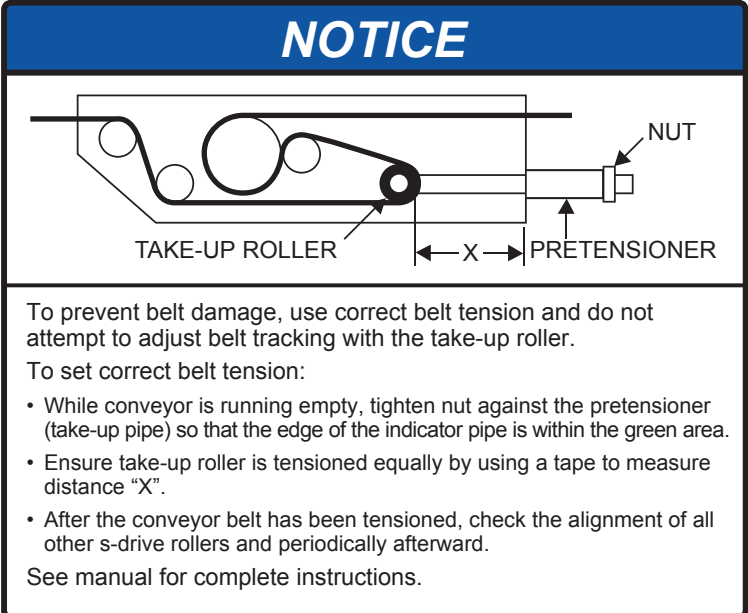
Part Number	Description
P1513032	<div style="border: 1px solid black; padding: 10px;"> <div style="background-color: #0056b3; color: white; text-align: center; padding: 5px;">NOTICE</div>  <p style="color: red; font-size: small;">NOTE: LEAVE THESE BOLTS SNUG UNTIL BELT HAS BEEN ALIGNED THEN THEY MAY BE TIGHTENED DOWN</p> <p style="color: blue; font-size: small;">NOTE: LEAVE THESE BOLTS SNUG SO GEARBOX MOUNT CAN FLOAT</p> <p>To prevent damage, tighten/snug bolts as shown when assembling or maintaining the conveyor.</p> </div>
P1513052	<div style="border: 1px solid black; padding: 10px;"> <div style="background-color: #0056b3; color: white; text-align: center; padding: 5px;">NOTICE</div> <p>To prevent damage, wheels must be free to move when raising or lowering equipment.</p> <p>When equipment is positioned, chock all wheels.</p> </div>

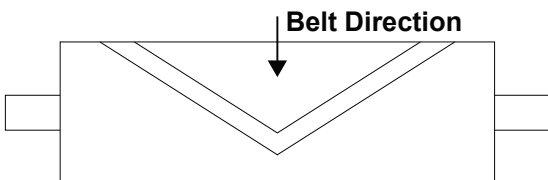

Table 1 Safety Decals (continued)

Part Number	Description
P1513049	<div style="border: 2px solid black; padding: 10px; text-align: center;"> <h1 style="margin: 0;">IMPORTANT</h1> <p style="font-size: 1.2em; margin: 10px 0;">Lubricate belt release and motor mount sliders with silicone or light oil.</p> </div>
P1513055	<p>The diagram illustrates the belt release mechanism. It shows a long, angled arm pivoted at its base. Four callouts identify key components: 1 (left vertical slider), 2 (right vertical slider), 3 (middle horizontal slider), and 4 (pivot point). Below the main diagram, a detailed view shows the sliders and pivot with red arrows indicating their movement directions: vertical for 1 and 2, horizontal for 3, and rotational for 4.</p>

3. Features

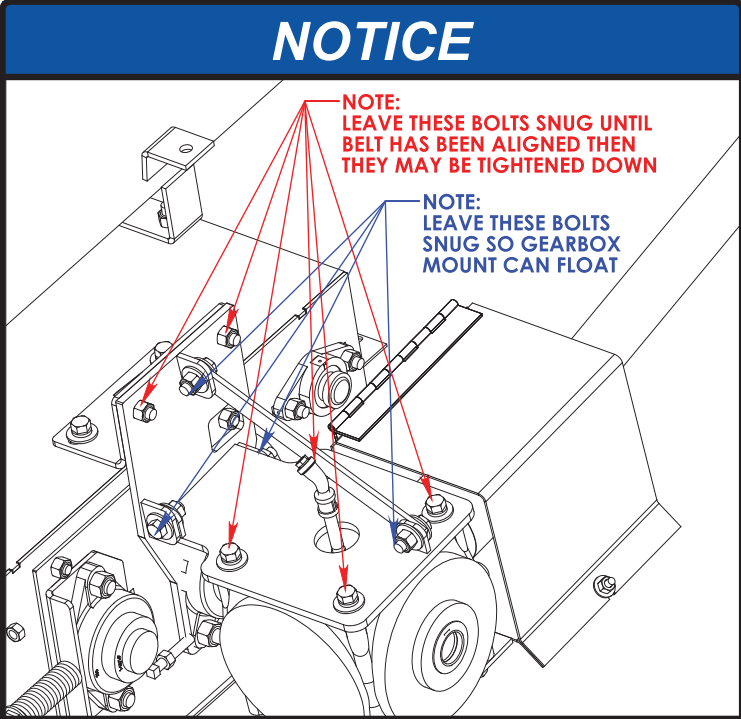
This section covers the main features of the conveyor.

Figure 10. Typical S-Drive Standard Conveyor Components (Scissor-Lift Conveyor)

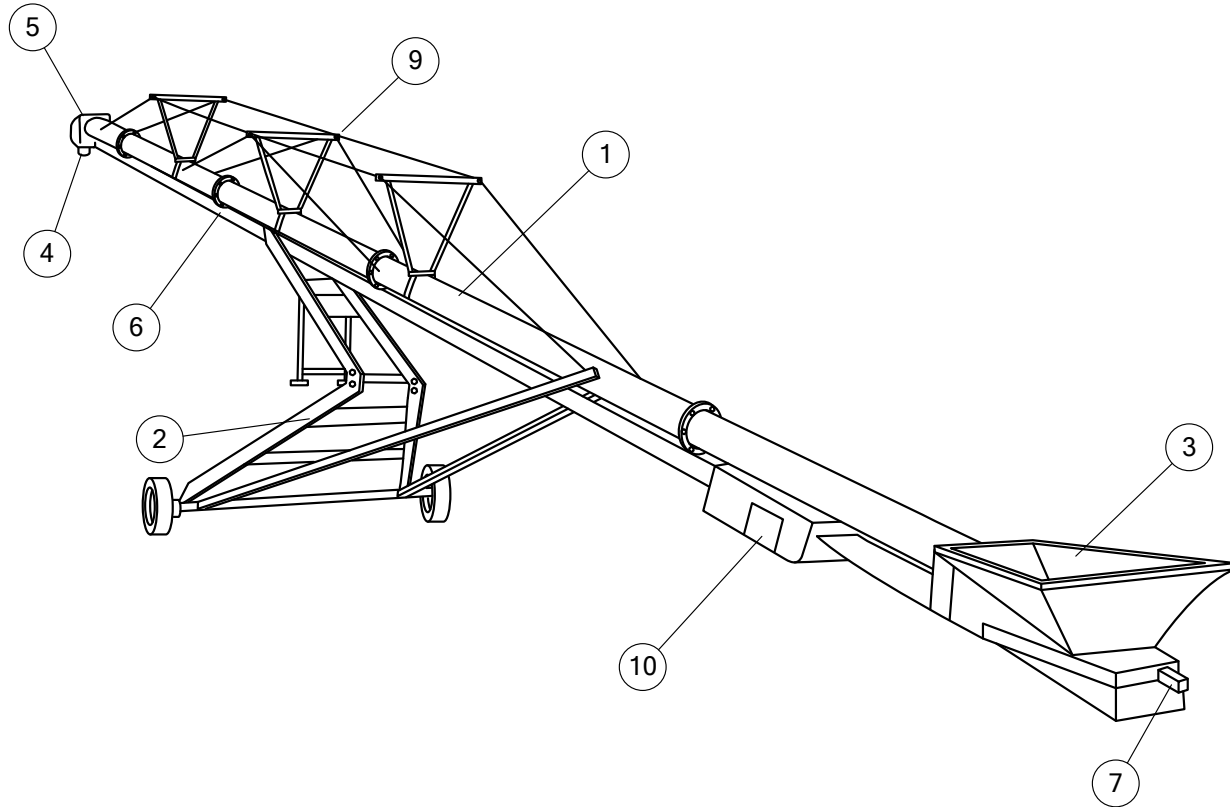

Table 2. Typical S-Drive Standard Conveyor Components (Scissor-Lift Conveyor)

Item	Description
1	Tube
2	Scissor Frame
3	Hopper
4	Spout Assembly
5	Hood

Item	Description
6	Belt Return and Weather Guard
7	Hitch
8	Jack (not shown)
9	Cable Truss
10	S-Drive



3.1. Model Number

XXXX

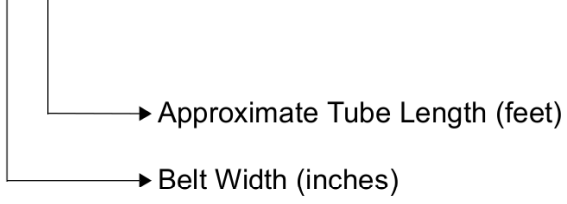

4. Transport



Before continuing, ensure you have completely read and understood this manual's Safety section, in addition to the safety information in the section(s) below.

4.1. Transport Safety

WARNING

- Check with local authorities regarding transport on public roads. Obey all applicable laws and regulations.
- Always travel at a safe speed, never exceeding 20 mph (32 km/h). Reduce speed on rough surfaces. Use caution when turning corners or meeting traffic.
- Yield to other drivers and allow faster traffic to pass.
- Make sure the SMV (slow moving vehicle) emblem and all the lights and reflectors that are required by local authorities are in place, are clean, and can be seen by all over-taking and oncoming traffic. Always use hazard-warning flashers on tractor/towing vehicle when transporting unless prohibited by law.
- Do not transport during times of limited visibility such as fog, snow, or heavy rain. Take extra precautions at night and at dusk.
- Keep others away from the transport vehicle and conveyor.
- Do not allow riders on the conveyor or towing vehicle during transport.
- Stay away from overhead obstructions and power lines when operating and transporting. Electrocutation can occur without direct contact.
- Fully lower the conveyor before transporting, and only raise when next to storage facility.
- Attach to a proper towing vehicle with a pin and retainer. Always attach safety chain(s).
- Do not raise the intake end above drawbar, upending may occur.
- Empty conveyor of all grain before transporting. Transporting a full conveyor will place excessive loads on the tube, frame, axle, hitch, and tow vehicle.
- Do not transport on slopes greater than 20°.
- Do not transport with an under-inflated tire(s).
- If the conveyor wheels are partially or fully buried in snow or grain, failure to clear area around the wheels before transporting may cause damage to the conveyor or result in serious injury.

4.2. Transport Preparation

1. It is not recommended that the conveyor be transported faster than 20 mph (32 km/h). [Table 3](#) references the acceptable transport speed as per the ratio of tractor weight versus conveyor weight. See Specifications for conveyor weights.

WARNING

A weight imbalance between the and the towing vehicle could result in a collision from reduced stability, handling, and braking ability.

2. Ensure the conveyor will clear any overhead obstructions or electrical wires prior to transporting. Refer to Specifications for the transport height of your conveyor.



- Longer conveyors have a large turning radius. Allow ample room for turning as the discharge end may swing dramatically. Allow all oncoming traffic to pass before turning right or left.

**WARNING**

A collision with an oncoming vehicle could occur if the conveyor discharge swings into the opposing lane.

Table 3. Speed versus Weight Ratio

Road Speed	Weight or fully equipped or loaded implement(s) relative to weight of towing machine
Up to 32 km/h (20 mph)	1 to 1, or less
Up to 16 km/h (10 mph)	2 to 1, or less
Do not tow if	More than 2 to 1

4.3. Connect the Conveyor to the Towing Vehicle

This section provides an overview of how to connect the conveyor to the towing vehicle. For specific information on the components, refer to the applicable section.

Follow all safety precautions when transporting the conveyor and use a proper towing vehicle.

- Fully lower the conveyor, there should be slight tension on the lift cable.
- Connect the conveyor to the two vehicle with a hitch pin. Use a hitch pin that will not allow the conveyor to separate from the towing vehicle.
- Connect the safety chain securely, forming a cradle to prevent the conveyor from digging into the road surface (should a breakaway occur). Do not use the safety chain if one or more links or end fittings are stretched, broken, damaged, or deformed.

Important

The safety chain should have a load rating at least as high as the conveyor weight.

- Use caution when transporting the conveyor over rolling terrain. In severe dips, the intake end may contact the ground.

Refer to [Section 9. – Specifications on page 71](#) for conveyor weight and hitch pin information.

5. Placement



Before continuing, ensure you have completely read and understood this manual's Safety section, in addition to the safety information in the section(s) below.

5.1. Placement Safety

WARNING

- The conveyor is not insulated, keep away from overhead power lines. Electrocution can occur without direct contact.
- Anchor intake end before using.
- Place the conveyor on reasonably level ground before operating. The conveyor could topple if ground is too uneven.
- Chock the conveyor wheels after placement.
- Empty the conveyor before raising, lowering, or positioning.
- Check that wheels are free to move before raising or lowering the conveyor.
- Never attempt to increase height of the conveyor by positioning wheels on lumber, blocks, or by any other means.
- Do not permit anyone to stand beneath the conveyor when raising or lowering.
- Move the conveyor into position slowly. Do not unhitch and attempt to move by hand.
- Do not leave tube in raised position when not in use.

5.2. Positioning the Conveyor

To position the conveyor using a tractor:

Filling Bins

1. Back the conveyor up to the bin while it is in its lowered configuration.
2. Set the park brake on the tractor before dismounting.
3. Raise the conveyor so it clears the bin.
4. Slowly back the conveyor up until the outlet is over the opening in the bin.
5. Unhook the conveyor from the tractor and lower the intake end to the ground.

WARNING

Upending hazard, do not hook or unhook hitch unless weight is down.

6. Slowly lower the conveyor spout to the bin.

NOTICE

Do not rest the spout or hood on the bin. This may cause hood or belt damage.

7. Remove the hitch from the conveyor to prevent interfering with other equipment.
8. Place chocks in the front and back of each wheel and anchor the intake end.

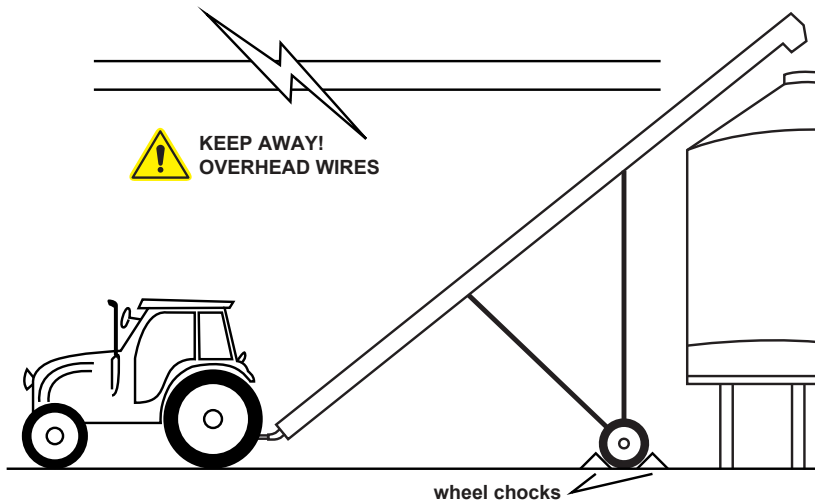

Figure 11. Typical Grain Conveyor Placement for Filling Bins**Under Hopper Bottom Bins**

1. Center the conveyor between the hopper bin's vertical legs.
2. Collapse the cloth hopper until the conveyor is fully positioned under the bin.
3. Move the conveyor into place. Do not allow the conveyor tube or components to contact the bin.
4. Raise the conveyor to the desired height.
5. Make sure that gravel is not jammed against the belt under the hopper.
6. Place chocks in the front and back of each wheel and anchor the intake end.

5.3. Extendable Axle Positioning

➡ When equipped with extendable axles:

Important

Do not raise the conveyor unless the axles are in the extended position. Do not transport the conveyor unless the axles are in the retracted position.

⚠ WARNING Rollover can occur if axles are not extended before raising the conveyor.

1. Ensure the conveyor is on level ground before attempting to extend or retract the axles. **The conveyor must be attached to tractor at all times.**
2. Using the jack supplied, insert it into one of the jack stubs located on one end of the axle. Jack must be secured to jack stub using pin (attached to jack).
3. Raise one side at a time. Raise until the tire clears the ground.
4. Remove the axle pin from the axle and position the axle as desired until the holes line up. Reinsert the axle pin and secure with hairpin. Lower the jack.
5. Repeat the process on the opposite side of the axle.

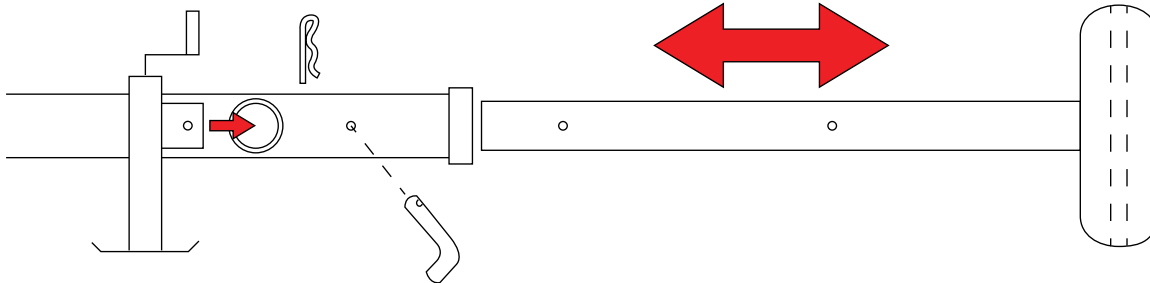
Figure 12. Typical Extendable Axle

5.4. Positioning the Conveyor with a Wheel Move Kit

➡ When equipped with a Wheel Move Kit:

Before Operating the Wheel Move Kit:

- Ensure the area around the conveyor is reasonably level and there is adequate clearance for making wide turns.
- Check the hydraulic oil to ensure that the levels are correct.

NOTICE

Running the machine on low oil will overheat the system causing components to break down.

To Operate the Wheel Move Kit:

1. Engage the over-center handle at each wheel ([Figure 13 on page 39](#)) and check that the gears are fully meshed. If necessary, refer to Pinion Gear Adjustment section.

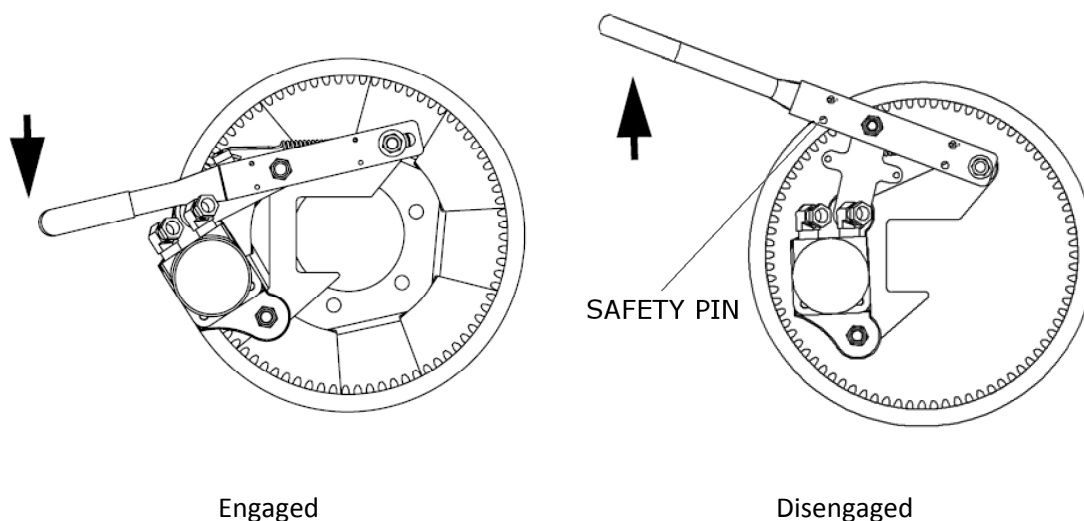
Figure 13. Wheel Over-Center Handle Positions

2. Set and run the gas engine at approximately half throttle.
3. Refer to the controls shown in [Figure 14](#).
4. Before moving the conveyor into position:

- Fully lower the conveyor.
- Raise the intake end slightly off the ground to position the conveyor.
- Raise the conveyor discharge end only for final positioning such as when next to a storage bin or grain truck.

Figure 14. Wheel Move Kit Controls

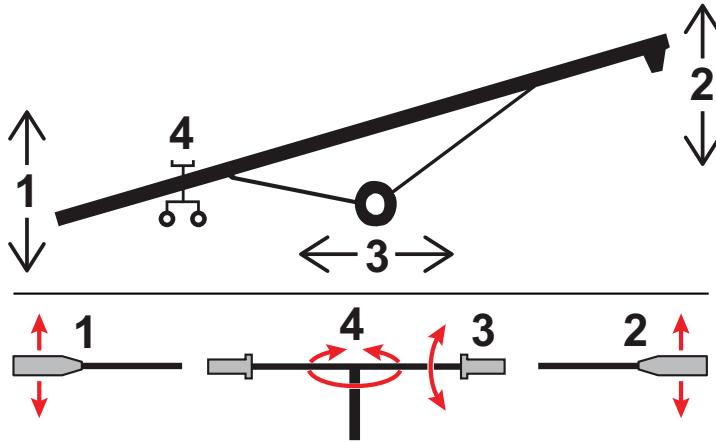

If Operating the Wheel Move Kit in Temperatures Below -10°C (14°F):

- Disengage the pump when starting the motor cold. This will put less pressure on the starter and allow the motor to turn over easier, helping it to start.
- Allow the hydraulic oil to warm before using the self-propelled kit.

NOTICE

Failure to warm the hydraulic oil can damage the pump or other components.

When Operation of the Wheel Move Kit is Complete:

1. Secure the wheel move kit axle to the conveyor when operation is complete or before transporting.
2. Fully disengage the over-center handles and secure the handle with the attached pin, see [Figure 15 on page 41](#).

NOTICE

Do not transport with the over-center handles engaged or damage to the wheel move kit motors will occur.

Figure 15. Chain Position



3. Disengage the pump to take the strain off the conveyor drive components.

NOTICE

Ensure that the over-center bolts are tight enough to prevent the handle from engaging. If they are not tight enough, damage to the gears and motor will result.

5.5. Raising and Lowering

➡ When equipped with a Hydraulic Lift Cylinder:

The intake hopper must be off the ground when raising and lowering the conveyor.

Before using the hydraulic lift cylinder:

- The hydraulic cylinders are shipped without oil and must be charged with oil before operating the first time. See the Appendix section for charging instructions.
- Check that the hydraulic hoses are free from leaks, binding, flattening, kinks, or wear.

Raising

1. Before connecting the hydraulic hose, wipe the hose coupler clean.

NOTICE

Dirt in the hydraulic system can damage the cylinder o-rings and can cause leakage and failure of the system.

2. Connect the hydraulic hoses, ensure the connections are tight. Visually check for leaks, binding, flattening, kinks, or wear.
3. Open the ball valve on the hose connected to the cylinder.
4. Start tractor and idle at low rpm.
5. Engage hydraulic lever to power the cylinder.
6. Increase tractor rpm until desired rate of lift is reached.

7. Raise the conveyor to the desired height.
8. Close the hydraulic ball valve when the conveyor is fully raised.

NOTICE

Failure to close the ball valve will cause the frame to lower, damaging the conveyor.

Lowering:

1. Reconnect the hydraulic hose coupler to tractor, if disconnected. Keep the tractor running while lowering the conveyor should the need arise to re-lift it.

NOTICE

Some conveyors are equipped with dual acting hydraulic cylinders, for these units the tractor must be running to pump oil to the upper chamber of the hydraulic cylinder(s) to prevent overfilling of the tractor reservoir.

2. Open the ball valve.
3. Open the tractor valve, feathering the control to prevent too rapid a descent.

Note

Once the valves are opened, the conveyor tube lowers by gravity. As the tube nears the full down position, the rate of descent will increase. Do not operate with the tractor valve fully open.

4. Turn off the tractor, and lock out the tractor power source.
5. Before disconnecting hydraulic couplers, relieve the hydraulic pressure.

**WARNING**

Disconnecting a hydraulic hose under pressure can result in serious injury.

6. Adjust the conveyor in the full down position until there is a slight tension on the lift cable. Do not leave the cable slack.

5.6. Collapsible Hopper Cloth

The conveyor is designed with a collapsible hopper cloth to allow it to go under low discharge units.

Push the hopper down and secure with hook. Push down again to release the hook and raise the hopper cloth. Refer to [Figure 16 on page 42](#).

Figure 16. Typical Collapsible Hopper

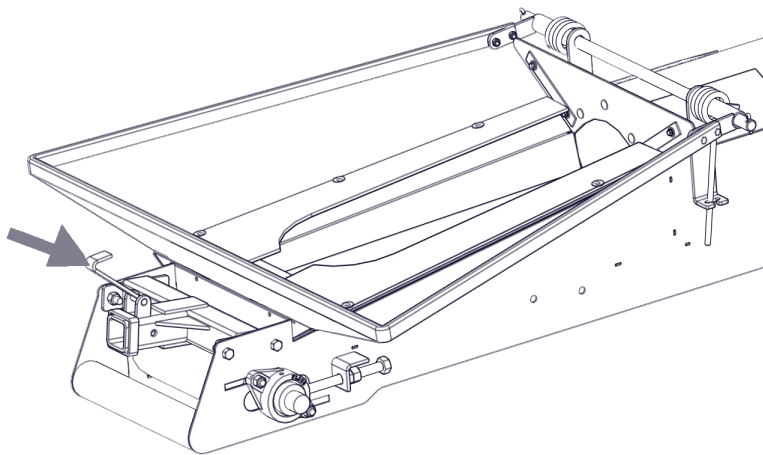

5.7. Conveyor Operating Angles

The conveyor lift can set the tube angle up to 30° when operating. Because the belt does not have roll back barriers, the material will roll back if the angle is too steep. Do not position the conveyor at an angle steeper than the grain will roll back (angle of repose) of the material to be moved.

Note

The lower the angle, the greater the capacity of the conveyor.

The following table indicates the maximum angle a conveyor can move grain.

To roughly determine conveyor angle, use angle guide on right. Stand the manual (vertically) on conveyor tube and hold a string with a weight attached to end against the top of this page. Weighted end of string will fall between degree lines, and from this the approximate angle of the conveyor can be determined.

Figure 17. Conveyor Operating Angles

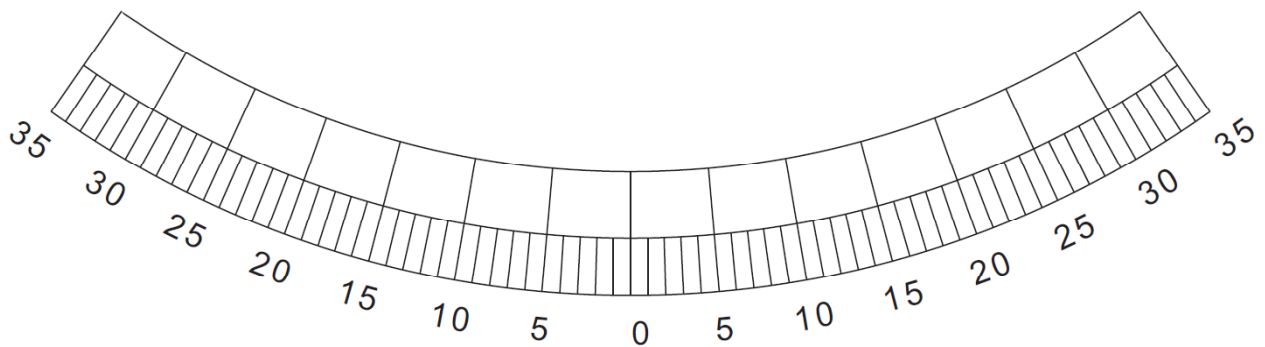
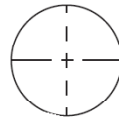
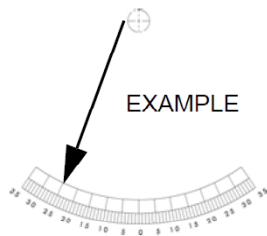

Table 4. Maximum Conveying Angles for Grains

Grain	Maximum Conveyor Operating Angle (degrees)
Flax	24
Lentils	29
Mustard	26
Oats	28
Peas	30
Rice	36
Rye	25
Soybeans	28
Sunflower	22
Triticale	23
Wheat	26
Alfalfa Pellets	34
Barley	25
Canary Seed	26
Chickpeas	30
Corn	23
Shelled Corn (dry)	23
Shelled Corn (wet)	28
Cotton Seed	30-45
Durum	23

6. Operation



Before continuing, ensure you have completely read and understood this manual's Safety section, in addition to the safety information in the section(s) below.

6.1. Operation Safety

WARNING

- Keep away from rotating and moving parts, including the conveyor belt, drive components, shafts, and bearings.
- Do not enter the grain bin while the conveyor is operating.
- Always operate with guards, covers, and shields in place.
- Have another trained person nearby who can shut down the equipment in case of accident.
- Keep the work area clear of bystanders.
- Keep the work area clean and free of debris.
- Ensure maintenance has been performed and is up to date.



Refer to your bin operation manual for specific operating and safety information for your bin.

6.2. Start-up and Break-in

Although there are no operational restrictions on the conveyor when used for the first time, it is recommended that the following items be checked during the first hours of operation.

1. Check that the conveyor intake and discharge areas are free of obstructions.
2. Check conveyor belt alignment to ensure preset alignment does not vary under loaded conditions. See Maintenance Section for alignment instructions.
3. Check the conveyor belt tension. See Maintenance Section for tension instructions.
- ➔ 4. **Gas and Electric Drive Models:** Check the drive belt tension and alignment. See Maintenance Section for instructions.
5. Check the pinch roller bearings on the s-drive pinch roller are not tight.
6. Visually inspect the conveyor, see Visual Inspection in Maintenance Section.
7. Check tightness of all bolts/nuts, fasteners, and hardware (re-torque if necessary).
8. Start the conveyor and operate normally, refer to power source instructions for further detail.
9. Be aware of unusual sounds. If any are heard, determine the source and stop the conveyor. Lock out and correct the problem before resuming work. If you are unsure of the problem or procedure, contact your local dealer.
10. Do not run the conveyor for long periods of time without material on the conveyor belt because it increases wear. Try to run only when moving material.
11. Stop the conveyor when it is empty of grain and lockout power, lower fully.



Important

After the initial start-up and inspection, the conveyor should be shut down and visually inspected (see Maintenance Section) after approximately ten hours of operation.

6.3. Operation - Electric Motor Models

➡ When equipped with an Electric Motor:

1. Turn the electric motor on.
2. Run until the conveyor is empty.
3. Turn off motor and lock out power source.
4. Unplug the power cord, wrap around the equipment and secure to prevent dragging, especially when transporting or placing the conveyor.

6.4. Operation - Gas Engine Models

➡ When Equipped with a Gas Engine:

1. If the drive belts are tight, disengage the belts.
2. Start the gas engine. Follow instructions provided with the gas engine for specific starting instructions.
3. Engage belt drive lever (when equipped).

Note

The drive belt should be just tight enough to not slip on the drive pulley. If the belt is too loose, it will slip, lowering power transfer from the engine and possibly causing a squealing sound. If the belt is too tight, it will cause excess wear.

4.

Note

The drive belt should be just tight enough to not slip on the drive pulley. If the belt is too loose, it will slip, lowering power transfer from the engine and possibly causing a squealing sound. If the belt is too tight, it will cause excess wear.

5. Adjust gas engine to provide maximum engine RPM.
6. Run until all grain has been emptied from the equipment.
7. Reduce engine speed to low idle.
8. Shut off engine and lock out power source.
9. Shut off fuel supply.

6.5. Operation - PTO Drive

1. Attach the PTO driveline securely to the tractor and confirm the connection to the conveyor shaft is secure.
2. Confirm the PTO driveline rotating shield and other shields/guards are in place and in good working order.

- Align the tractor axis with the conveyor input shaft to minimize the angles of the universal joints on the PTO driveline.

Important

Check that the PTO does not exceed the maximum operating angle, refer to [Section 9. – Specifications on page 71.](#)

- Ensure the PTO drive on the tractor is in the off position before starting the tractor.
- Start tractor engine at low idle, slowly engage the PTO with the tractor idling to prevent unneeded stress on the drive components and shear bolts.
- If everything is operating normally, start running grain through the conveyor and increase the tractor PTO to the specified full speed to produce the required flow.
- To shut down, reduce the speed to low idle and lock out the PTO.
- Disconnect the PTO driveline from the tractor and secure it to the PTO transport saddle with the safety chain and keep it in transport saddle when transporting.

When raising or lowering the conveyor:

Disconnect the PTO driveline.

When starting under load:

If restarting the conveyor under load (tube is full), engage the PTO with the tractor idling.

NOTICE Engaging the PTO at high engine speed under load will result in equipment damage.

6.6. Loading Area

To achieve maximum capacity:

- Feed material onto the belt until the material tube clearance is 1/2".
- Direct the flow of material into the input hopper in the direction of the belt travel for the best capacity.

Do not flood feed the hopper.

6.7. Conveyor Belt Speed

The best results are obtained when the input drives are set to provide a conveyor belt speed of 500 to 600 ft/min on the 1500 series, and 600 to 650 ft/min on the 1800, 2000, and 2400 Series.

Count the number of belt revolutions per minute to determine belt speed. See Specifications for belt length.

Note

Use the connector splice as a reference when counting belt revolutions.

To calculate, for example, 600ft/minute belt speed for a 47ft belt:

$$\frac{\text{BeltSpeed}}{\text{BeltLength}} = \frac{600}{47} = 12.76$$

Therefore, 12.76 or approximately 13 belt passes per minute will provide a 600ft/min belt speed.

Contact your dealer or the factory for the appropriate drive components to give the recommended belt speed.



If the belt speed is too low, conveyor may leak around transition area.

6.8. Emergency Shutdown

In an emergency situation:

1. Stop or shut down the power source immediately and lock out all power.
2. Stop the flow of material (if applicable).
3. Ensure the machine components come to a stop before inspecting.
4. Correct the emergency situation before resuming work.

6.9. Restarting with a Full Tube

When the conveyor is shut down inadvertently or due to an emergency, the tube may still be filled with grain.

1. With the power source locked out, remove as much of the grain as possible from the tube and intake using a shop vacuum or other tool. Do not use your hands.

NOTICE

Starting under load may result in damage to the conveyor.

2. If guards or covers have been opened or removed, close or replace them before restarting the unit.
- ➡ 3. **Electric and Gas Drive Models:** It may be necessary to tighten the drive belts slightly to handle the heavier than normal loads.
- ➡ 4. **Gas and PTO Drive Models:** Since the start-up torque loads are so much higher than normal when the conveyor belting is full, restart at low speed. Do not let the conveyor belt drive roller spin on the belt if conveying belt does not start moving immediately. This will damage the drive roller and conveying belt.
5. Once the conveyor has been started, you may resume normal operation.

6.10. Shutdown

When operation has been completed:

1. Once the conveyor is clear of grain, lock out the power source.
2. Lower the conveyor fully.
3. Clean out any remaining grain from the conveyor with a vacuum or sweep out.
4. Clean the entire work area.
5. Remove anchors, supports, and chocks.

6.11. Clean Out

After using your conveyor, follow the clean out steps below to ensure longer belt life and trouble free operation. Failure to clean out the conveyor can cause build up of product on the belt and roller shafts, causing spillage, roller misalignment, and excess wear/damage to the belt.

 **WARNING** Failure to lock out power can cause severe injury.

1. Remove any product remaining in the hopper and spout with a vacuum or sweep out.
2. Remove debris from shafts, sheaves, and drive belts (as equipped).
3. Once the conveyor is empty of all product, check for damage on belt and lacing such as notches or cut outs. Any damage on belt may result in product getting under it creating a build-up. If belt replacement and re-lacing is necessary, refer to the Maintenance Section.

Important

Ensure the conveyor is free from all product and debris to prevent build-up. Any build-up on belt and shaft becomes a source of spillage and can cause belt misalignment with the possibility of belt edges sustaining damage on the fixed structure. Build-up on the hopper and spout will cause the belt to wear faster due to drag.

4. Once cleaned out, cover intake to prevent moisture from collecting in hopper.

6.12. Conveying Fertilizer

Fertilizer may be conveyed using the conveyor when strictly operated at a reduced capacity and additional care is taken to thoroughly clean the conveyor after operation.

Important

Fertilizer weakens the belt lacing and warranty is void on all lacing used with fertilizer. The belt lacing may need to be replaced more often if you convey fertilizer.

Additional Operating Requirements

To prevent problems that can be caused by conveying fertilizer:

1. Do not allow fertilizer to fill over the edge of the belt. This will allow fertilizer to get under the belt and start building up.
2. Reduce the flow if the conveyor belt starts to slip. Denser fertilizers will slow the conveyor belt down due to the weight of the product. Too much material will cause the drive roller to slip and lead to additional wear on the roller.
3. Do not move fertilizer with your conveyor in humid, wet or rainy conditions. This will cause buildup of fertilizer under your conveyor belt.

Additional Clean-Out Procedures

Proper cleaning will help to ensure longer belt life and prevent excess rust formation.

1. Run conveyor empty at full speed for 5-10 minutes after conveying fertilizer. This will help ensure that any product that may be under the belt will be cleaned out and prevent build up.

 **WARNING** Do not attempt to manually remove build-up while conveyor is running.

2. Next, run the belt at low idle and inspect for damage on the belt and lacing, such as notches or cut outs caused by mice and normal wear. Any damage on the belt may result in fertilizer getting under the belt creating a buildup. Consider replacing the conveyor belt if it is in poor condition. If equipped with an electric motor, inspect on the belt return side with the electric motor not running. Turn on the conveyor to expose the belt that was previously in the tube. Turn off the conveyor and inspect the belt on the belt return, along with the lacing.



3. Shutdown and lockout power to the conveyor and vacuum or sweep out any remaining fertilizer from the hopper.
4. Remove the s-drive bottom cover and remove any buildup from this area and clean cover. Replace the cover when complete.
5. If buildup is evident on or under the belt, remove the buildup to ensure proper operation of the conveyor. When necessary remove fertilizer buildup from under the belt by scraping and washing the belt.

Figure 18. Fertilizer Buildup on Rollers



Figure 19. Fertilizer Buildup at Hopper Transition

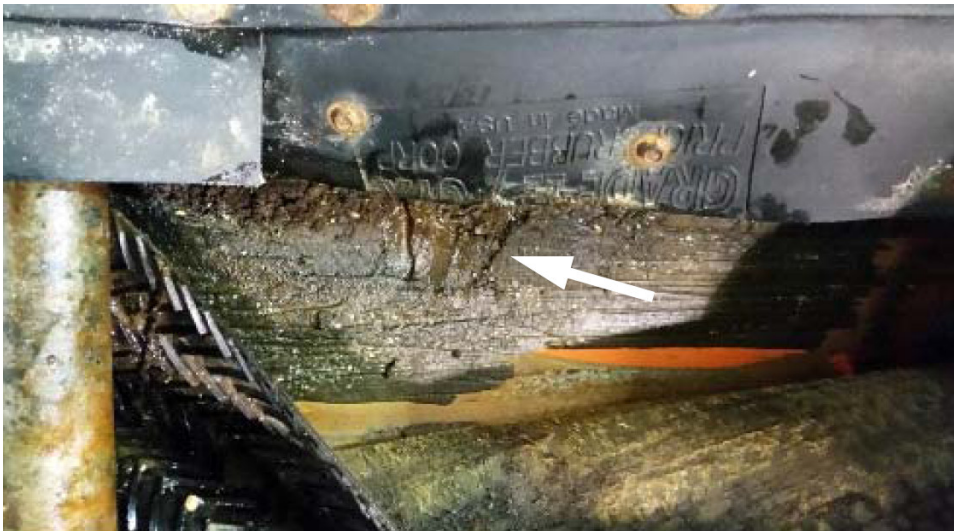

6.13. Storage

After the season's use, the conveyor should be thoroughly inspected and prepared for storage. Repair or replace any worn or damaged components and perform maintenance as described in the Maintenance Section to prevent any unnecessary downtime at the start of the next season.

To ensure a long, trouble-free life, this procedure should be followed when preparing the unit for storage.

1. Remove all residual material from the hopper and the tube.
2. Stop the machine with the belt lacing inside the tube. This helps prevent the lacing from rusting.
3. Wash the entire conveyor thoroughly using a water hose or pressure washer to remove all dirt, mud, debris, or residue.
4. Inspect all moving or rotating parts to see if anything has become entangled in them. Remove any entangled material.
5. Touch up all paint nicks and scratches to prevent rusting.
6. Check tire pressure and inflate. For inflation pressure, refer to [Section 9. – Specifications on page 71](#).
7. Inspect the conveyor for cracks, tightness of fittings and fasteners, hydraulic hose cracks (if applicable). Have required repairs performed to replace worn or damaged components.
8. Store in an area that is dry, level, free of debris, and away from human activity. Store inside if possible.
9. Cover the motor with waterproof tarpaulin if stored outside to protect from weather.
10. Chock wheels.
11. Support intake on blocks to eliminate prolonged contact with the ground.
- ➡ 12. **PTO Models:** Clean and lightly lubricate the spline on the PTO driveline. Cover the PTO driveline with a plastic bag to protect it from the weather and place it in the transport saddle.
13. Lower the conveyor fully for storage.



7. Maintenance

 Before continuing, ensure you have completely read and understood this manual’s Safety section, in addition to the safety information in the section(s) below.

7.1. Maintenance Safety

WARNING

- Keep components in good condition. Follow the maintenance procedures.
- Ensure the service area is clean, dry, and has sufficient lighting.
- Do not modify any components without written authorization from the manufacturer. Modification can be dangerous and result in serious injuries.
- Shut down and lock out power before maintaining equipment.
- After maintenance is complete, replace all guards, service doors, and/or covers.
- Use only genuine Batco replacement parts or equivalent. Use of unauthorized parts will void warranty. If in doubt, contact Batco or your local dealer.



Before attempting maintenance of any kind:

- Lower the conveyor fully.
- Chock wheels.
- Support tube if performing maintenance on the undercarriage assembly.
- **If equipped with hydraulics:** Before applying pressure to a hydraulic system, make sure all components are tight and that hoses and couplings are in good condition.

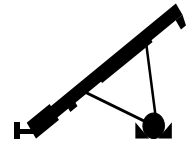

7.2. Maintenance Schedule

Proper maintenance habits mean a longer life, better efficiency, and safer operation. Please follow the Maintenance Schedule below. Keep good records of the hours the conveyor has been operated and the maintenance performed.

Daily:
Section 7.3. – Visually Inspect the Equipment on page 53
Section 7.4. – Lubricate the Equipment on page 54
Monthly:
When equipped: Section 7.7. – Inspect Hydraulic Hoses and Fittings on page 55

Section 7.8. – Inspect the Hopper Flashing on page 55
Section 7.9. – Check the Roller Bearings on page 55
Section 7.10. – Check the Roller Lagging on page 56
7.13. Inspect Belt Lacing on page 60
When equipped: Section 7.5. – Check the Gearbox Oil on page 54
Annually:
Section 7.11. – Tension the Conveyor Belt on page 56
Section 7.12. – Align the Conveyor Belt on page 58
Section 7.16. – Clean and Wash the Equipment on page 62
2–3 Years:
7.14. Replace the Belt Lacing on page 60
When equipped: Section 7.6. – Change the Gearbox Oil on page 55
As Required:
When equipped: Section 7.17. – Tension the Drive Belts on page 62
When equipped: Section 7.18. – Align the Drive Belts on page 63
When equipped: Section 7.19. – Replace the Drive Belts on page 63
Section 7.20. – Repack the Wheel Bearings with Grease on page 63
When equipped: Section 7.21. – Check/Adjust the Truss Cables on page 64
7.15. Replace the Conveyor Belt on page 60
Section 7.22. – Pinion Gear Adjustment on page 66

7.3. Visually Inspect the Equipment

Check the following during a visual inspection:

1. Ensure all guards are in place and in good working order.
2. Examine the conveyor for damage or unusual wear.
3. Check tightness of bolts/nuts, fasteners, and hardware (re-torque if necessary).
4. Be sure all safety decals are in place and are legible.
5. Check that the discharge and intake area are free of obstructions.
6. Inspect all moving or rotating parts to see if anything has become entangled in them. Remove any entangled material.

 **WARNING** Lock out power before inspecting.
7. **When equipped:** Inspect hydraulic hoses and fittings for leaks and wear. Fix or replace where necessary.
8. Check wheel bolts are tight and examine tires for gashes, uneven wear, or loss of air pressure. See [Section 9. – Specifications on page 71](#) for recommended tire pressure.



9. Check all operating, lifting, and transport components. Replace damaged or worn parts before using the conveyor.
- ➔ 10. **PTO Models:** Check the PTO shield & replace if damaged.
- ➔ 11. **If equipped with truss cables:** Inspect the truss cables for proper tension and possible damage such as fraying, kinking, or unwinding.

7.4. Lubricate the Equipment

Your equipment can operate at top efficiency only if clean fluids and lubricants are used. Use clean containers to handle all fluids and lubricants. Store them in an area protected from dust, moisture, and other contaminants.

1. Wipe the grease fittings with a clean cloth before greasing to avoid injecting dirt and grit.
2. Use a hand-held grease gun for all greasing.
3. If fittings will not take grease, remove and clean thoroughly.
4. Replace fittings if they are broken or will not accept grease.

Use SAE multi-purpose high-temperature grease with extreme pressure (EP) performance. SAE multi-purpose lithium-based grease is also acceptable.

7.4.1 PTO Driveline

Figure 20. Typical PTO Driveline Grease Points

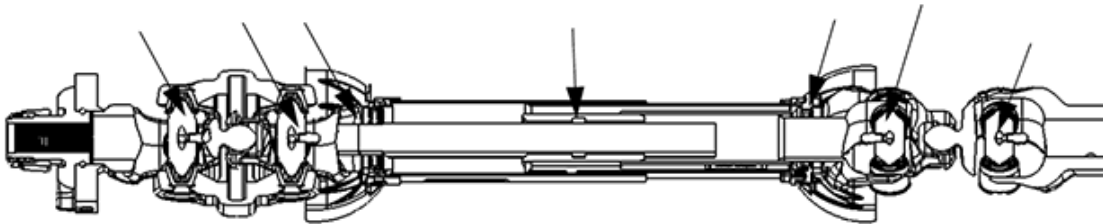
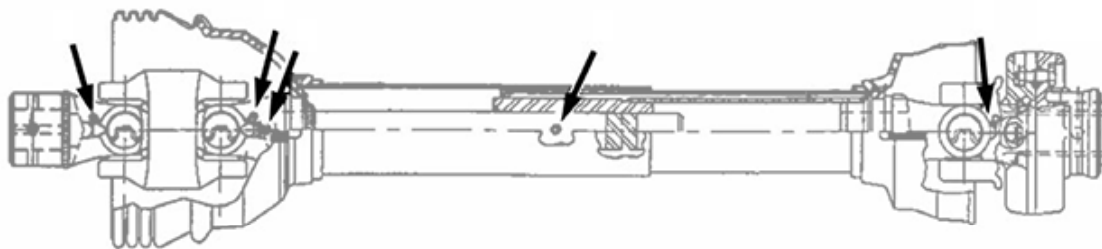

Figure 21. Typical PTO Driveline Grease Points



7.5. Check the Gearbox Oil

1. Remove fill/vent plug to check gearbox oil level. Insert an improvised dipstick (rolled paper or plastic tie) into the oil filler hole to determine the oil level.

2. Note the level and the condition of the oil. Maintain oil level at half full (center of cross shaft) with 90W or equivalent gear oil, adding as necessary or drain and refill if condition is poor.
3. Ensure gearbox is level when checking or refilling.
4. Do not overfill when adding oil.
5. Replace fill/vent plug.

7.6. Change the Gearbox Oil

Use SAE approved 90W or equivalent gear oil.

1. Remove gearbox from the conveyor.
2. Place a pan under the drain plug.
3. Use a wrench and remove the drain plug.
4. Loosen the filler plug so air can enter the gearbox and the oil will drain freely.
5. Allow the oil to drain completely.
6. Replace the drain plug.
7. Add oil until the gearbox is half full (center of cross shaft) and replace filler plug. A flexible funnel may be required. Gearbox should be level when checking or refilling. **Do not overfill.**
8. Reinstall the gearbox and guards.

7.7. Inspect Hydraulic Hoses and Fittings

➡ When equipped:

1. Pressurize the system.
2. Using a piece of cardboard or wood, run it along the length of the hose and around all fittings.
 **WARNING** Escaping hydraulic fluid under pressure will cause serious injury if it penetrates the skin surface.
3. Replace the hose or tighten/replace the fitting if a leak is found. For replacement hoses, refer to [Section 9. – Specifications on page 71](#).
4. Replace any hose that is badly cut, nicked, abraded, or is separating from the crimped end of the fitting.
5. Secure hoses to the machine.

7.8. Inspect the Hopper Flashing

Check hopper flashing for wear and replace any that are worn. Worn flashing will cause hopper leakage.

7.9. Check the Roller Bearings

Check the roller bearings for wear. Any rollers making noise, getting hot while running, or that give should be replaced.



7.10. Check the Roller Lagging

Inspect roller lagging to see if it is showing signs of wear.

NOTICE

Operating the conveyor with a damaged roller will result in a damaged conveyor belt.

7.11. Tension the Conveyor Belt

Adjusting your conveyor belt for proper tension helps to ensure trouble-free operation and long belt life.

The conveyor belt only needs to be tight enough to not slip on the drive roller. If the belt is too loose, it will slip on the drive roller making a noticeable sound, slowing the belt down.

The conveyor belt should not be easy to pull from the hopper transition sides, otherwise the belt will require tensioning.

NOTICE

Failure to stop using the conveyor with a slipping belt will damage it and/or the drive roller lagging. In extreme cases, sections of burnt belt will have to be replaced. This type of damage is not covered by warranty.

To set correct conveyor belt tension:

1. While the conveyor is running empty, fully tighten the nut against the pretensioner (take-up pipe) so that the edge of the indicator pipe is within the green area, see [Figure 22 on page 57](#).
2. Ensure the take-up roller is tensioned equally by using a tape measure to check the distance “X” on both sides.
3. After the conveyor belt has been tensioned, check the alignment of all s-drive rollers, see [Section 7.12. – Align the Conveyor Belt on page 58](#).
4. If the belt is still loose after tensioning, the belt needs to be shortened or replaced (depending on wear).

Figure 22. S-Drive

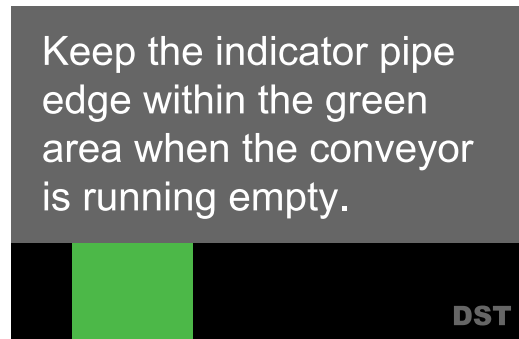
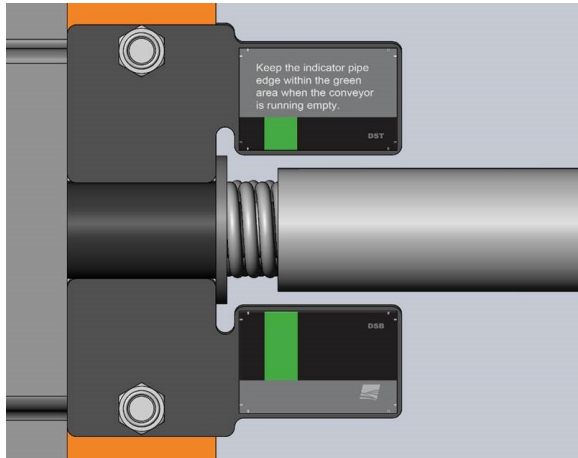
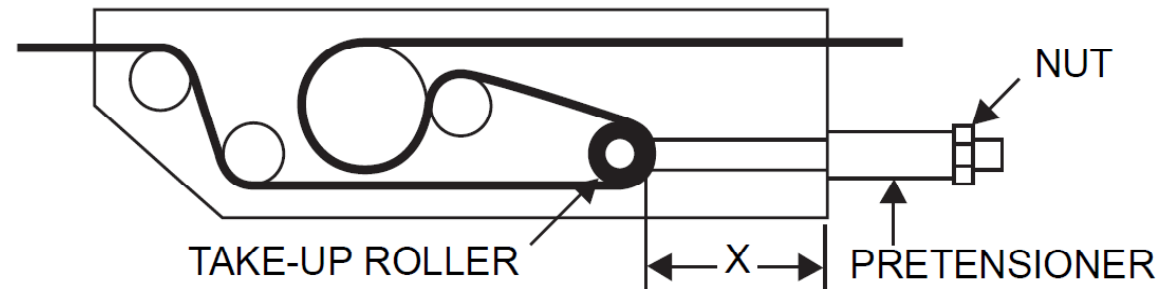

7.11.1 S-Drive Pinch Roller

The s-drive pinch roller should always be set with its flange nuts wiggle loose, allowing the spring to push against and pinch the conveyor belt. This should not normally require adjustment.

1. Do not tighten nuts. Bearing nuts must remain wiggle loose.
2. Tighten pinch spring, if loose.
3. Confirm that the pinch roller and drive roller are flush.

Figure 23. S-Drive Pinch Roller

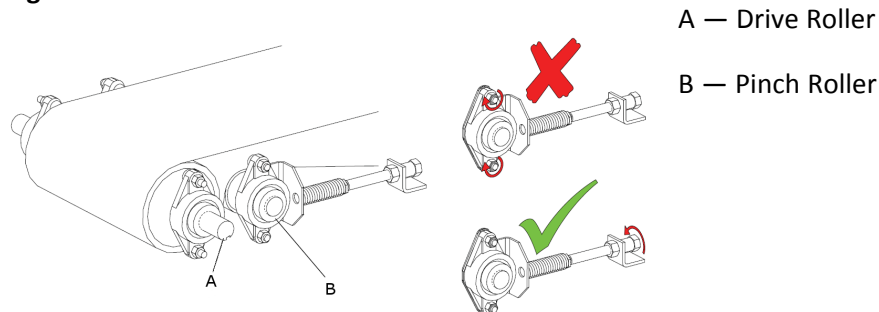

A — Drive Roller

B — Pinch Roller



7.12. Align the Conveyor Belt

WARNING Failure to lock out power can cause severe injury.

Basic Conveyor Belt Alignment:

The conveyor belt will run straight when all of the rollers are straight.

Loosen or tighten the adjustment bolt(s) to align the conveyor belt. Tighten the side the belt has moved toward, or loosen the side the belt has moved away from.

Figure 24. Roller out of Alignment

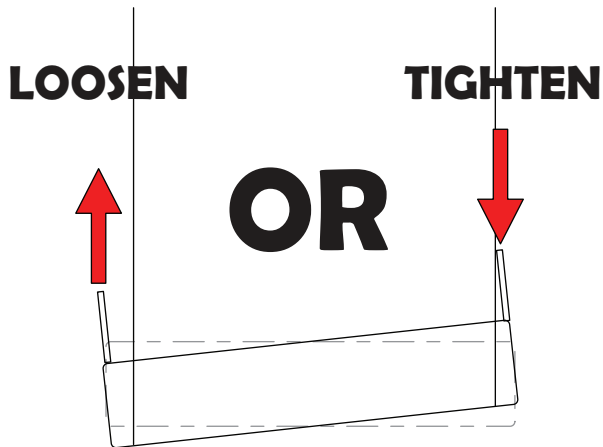

Before Aligning the Belt:

- The conveyor must be empty of all grain.
- Wait until the belt makes a complete revolution before adjusting the rollers. Some belts may have uneven edges, appearing misaligned.

To Align the Belt:

If your belt is tracking off-center, follow the sections and steps in the order following to center it.

Figure 25. Belt Tracking to One Side

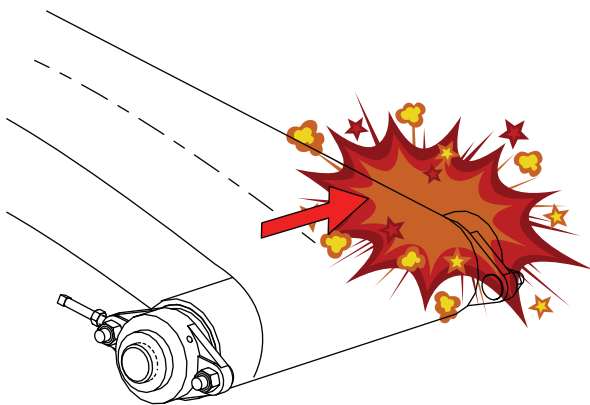

7.12.1 Adjust the Rollers

1. Loosen bearing nuts and jam nuts (if equipped).

Figure 26. Loosen the Bearing Nuts

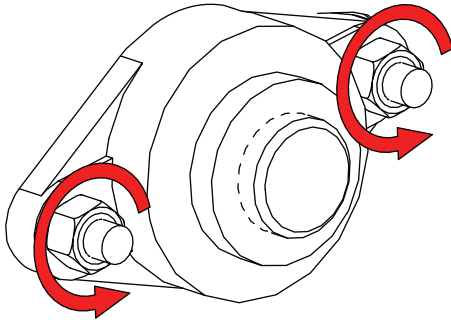

2. Rotate adjustment bolt 1/2 turn.

Figure 27. Rotate the Adjustment Bolt

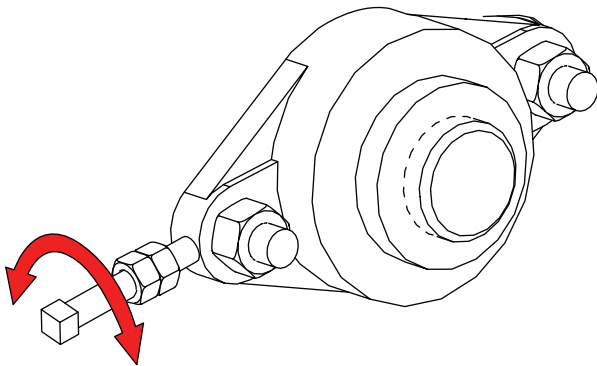

3. Restart conveyor and run empty for 1 minute.
4. Stop the conveyor and remove ignition key or lock out the power source.
5. If the belt has centered, move to next step. If not, repeat Step 2 to Step 4 until the belt is centered.
6. Tighten the bearing bolts and jam nut (if equipped).
7. Replace any guards that were removed.

7.12.2 Adjust the Belt Return Wear Blocks

1. Adjust the wear blocks by rotating them 90 or 180 degrees. If they are worn down, replace the wear blocks.

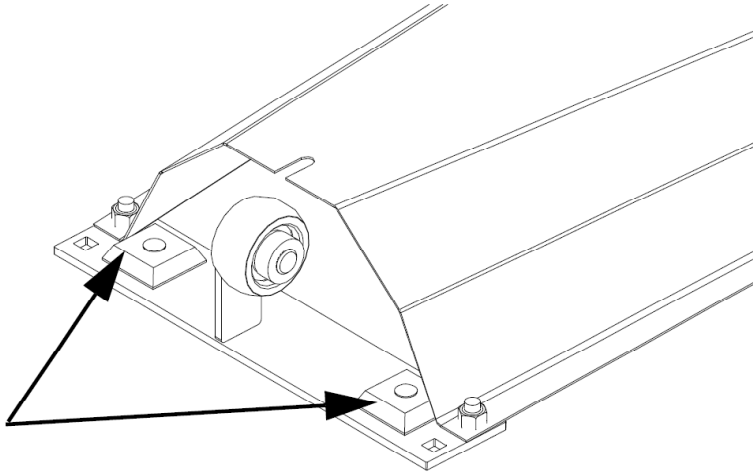

Figure 28. Belt Return Wear Blocks

2. Replace the guards if removed.

7.13. Inspect Belt Lacing

Inspect the condition of the belt lacing, if any clips are worn through, replace all lacing.

7.14. Replace the Belt Lacing

1. Rotate the conveyor belt until the lacing is by the hopper or is easily accessible.
2. Loosen the conveyor belt and remove the lacing retainer clip and pin.
3. Using a square and sharp knife, cut the lacing off right behind the lacing clips. The cut belt **MUST** have a square end.
4. Use a knife to cut Chevron pattern off 1" back from the end of the belt. This ensures that the lacing is centered and fully seated on the belt.
5. Use a lacing tool to install new lacing clips. Lacing clips are one clip shorter than the belt width. For example: the lacing for a 15" wide belt is 14 clips. Center the lacing on the belt and install the lacing as per instructions on the lacing tool.
6. Reattach the conveyor belt ends together. If required, use a ratchet strap clamped to both ends of the belt to cinch the belting ends together. [Figure 29 on page 61](#).
7. Install the lacing pin and crimp the retainer clips onto each end of the lacing pin. [Figure 30 on page 62](#).
8. Remove the ratchet strap and tighten the conveyor belt (see "Conveyor Belt Tension").
9. Check and set the belt alignment (see "Conveyor Belt Alignment").
10. Engage the conveyor drive. Allow the conveyor to run for 30 seconds, then shut down the conveyor and inspect the lacing.

7.15. Replace the Conveyor Belt

1. Rotate the conveyor belt until the lacing is by the hopper or is easily accessible.

2. Move the tension roller to its loosest position.
3. Pull all the slack to the lacing area.
4. Remove the lacing retainer clip and pin.
5. Attach one end of the replacement belt to the belt end being removed, closest to the hopper.
6. Pull the old belt out and the new belt will be threaded into place.
7. Disconnect the old belt.
8. Reattach conveyor belt ends together. If required, use a ratchet strap clamped to both ends of belt to cinch belting ends together. [Figure 29 on page 61.](#)

Figure 29. Using the Ratchet Strap

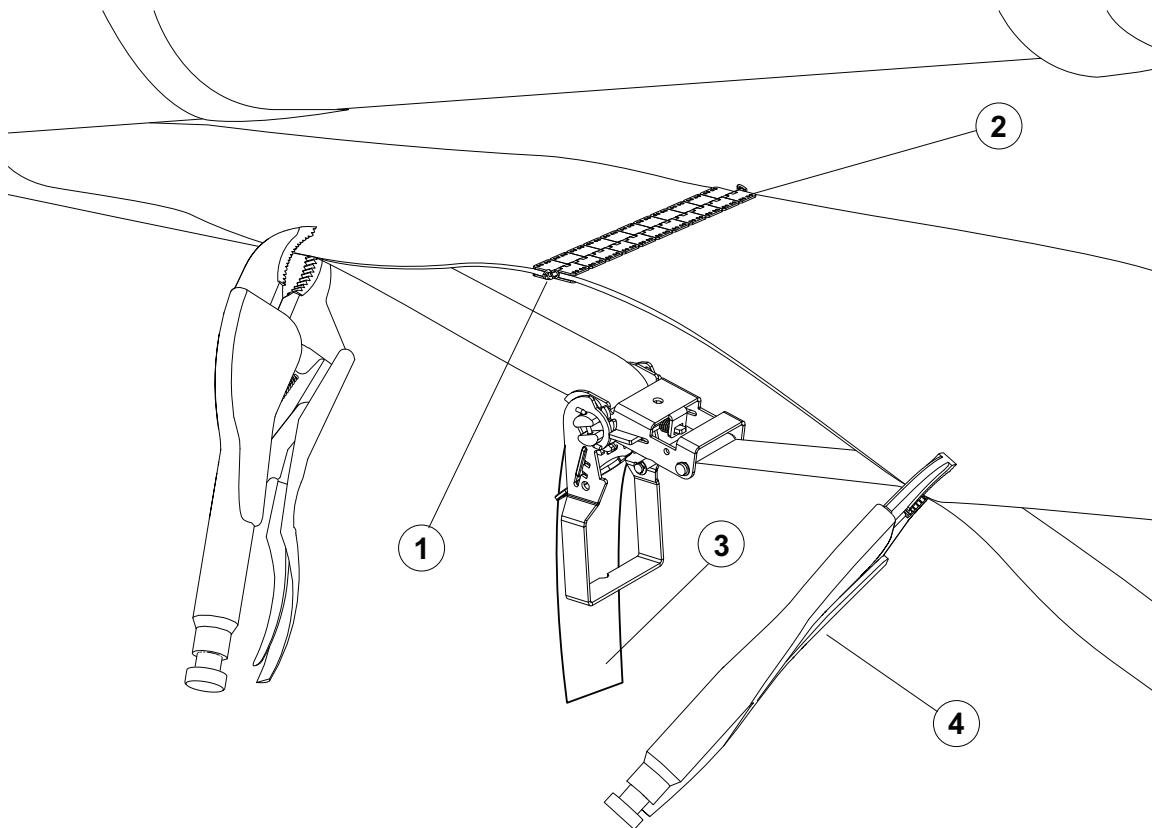

9. Install the lacing pin and crimp the retainer clips onto each end of the lacing pin, see [Figure 30](#).
10. Remove the ratchet strap and tighten the conveyor belt (see “Tension the Conveyor Belt”).
11. Check and set the belt alignment (see “Align the Conveyor Belt”).
12. Engage the conveyor drive. Allow it to run for 30 seconds, then shut down the conveyor and inspect the lacing.

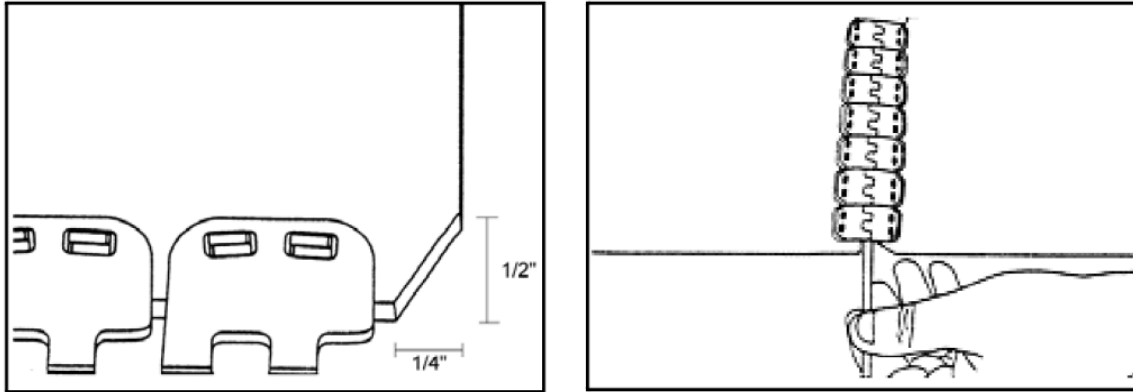

Figure 30. Lacing the Conveyor Belt

7.16. Clean and Wash the Equipment

1. Clean out excess grain from all areas of the conveyor.
2. Make sure water can drain from the conveyor tube and intake, then wash the tube with a water hose or pressure washer until all dirt, mud, debris, or residue is gone.
3. Provide sufficient time for the water to drain from the conveyor.

7.17. Tension the Drive Belts

➡ When equipped:

1. Remove guard and push on the center of the belt span with a force of approximately 5 lb.
2. The belts will deflect approximately 1" (25 mm) when properly tensioned.

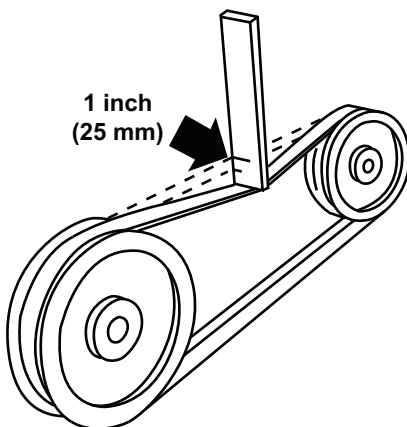
Figure 31. Typical Drive Belt Tensioning

3. Tighten or loosen the drive belts (or idler pulley when equipped) to achieve the proper tension.

Important

The drive belt should be just tight enough to not slip on the drive pulley when operating. If the belt is too loose, it will slip, possibly causing a squeaking sound and slowing the belt down. If the belt is too tight, it will cause excess wear.

4. Reattach and secure guard. Start system to ensure proper operation.

7.18. Align the Drive Belts

➡ When equipped:

1. Lay a straight edge across the pulley faces to check the alignment.
2. Use the pulley hub to move the pulley to the required position for alignment.
3. Tighten the hub bolts to secure pulley on the drive shaft.
4. Check the belt tension.
5. Reattach and secure the guard.

7.19. Replace the Drive Belts

➡ When equipped:

1. Remove the guard.
2. Fully loosen the drive belts.
3. Remove and replace the old belts.
4. Tighten the drive belts as described in Belt Tension.
5. Align the drive belts as described in Belt Alignment.
6. Reattach and secure the guard.

7.20. Repack the Wheel Bearings with Grease

1. Block wheels and ensure unit is stable.
2. Remove the wheel bolts and the wheels.
3. Clean wheel and hub mounting surfaces to ensure there is no rust or debris.
4. Remove the wheel bearing and pack with grease. Use SAE multi-purpose high-temperature grease with extreme pressure (EP) performance. SAE multi-purpose lithium-based grease is also acceptable.
5. Tighten the wheel bolts (diagonal pattern) with a torque wrench to 100 ft-lb (± 10 ft-lb) of torque. Inspect to make sure the wheel is sitting flush with the hub.

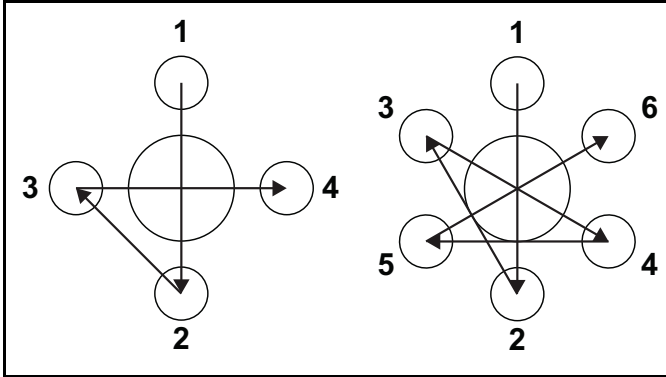

Figure 32. Diagonal Pattern for 4-bolt and 6-bolt Tires

7.21. Check/Adjust the Truss Cables

➡ When equipped with Truss Cables:

Check the Truss Cables:

Check tube for straightness, no slack in the cables, and a just noticeable upward deflection of the discharge end. During operation, it is normal that for the tube to deflect downward.

If required, adjust cables by following the procedure below:

1. Lift the discharge end of the conveyor with a overhead crane, front end loader, or other proper lifting device so that the tube has a slight upward deflection at the discharge to give the cable some slack.

⚠ CAUTION The lifting device must be capable of supporting approximately half of the weight of the conveyor as provided in the Specifications section.

- ➡ 2. When the conveyor has more than one set of cables start from the innermost cables and work your way out.
3. Loosen cable clamps on cable truss where the cable requires adjustment.
4. Locate the eyebolt anchors for the cable. Refer to [Figure 33 on page 65](#).
5. Tighten cable eyebolts evenly on both sides (use eyebolt nuts to tighten eyebolts) until the discharge end just starts to angle upward.
 - The tube should not deflect to the left or right if tightened evenly.
 - Tension should be greater on shorter cables than on longer cables. If the conveyor tubes remain straight then the cables are tensioned properly.
6. If the proper cable tension can't be obtained before the eyebolts run out of adjustment, then do the following:
 - a. Loosen the eyebolts.
 - b. At the eyebolts, loosen the cable clamps, shorten the cables until there is tension on the cable, then tighten the cable clamps fully.
 - c. Return to step 5.
7. Secure jam nut on cable eyebolt and re-tighten any cable clamps that were loosened.
8. The cables are properly tightened when:

- There is no slack in the cables.
- The discharge end is deflected slightly upwards.
- The tube is straight side-to-side.

Table 5. Truss Cable Adjustment

Item	Description
1	Cable Clamp
2	Truss Cable
3	Cable Return Bracket
4	Cable Eyebolt
5	Eyebolt Nuts
6	Eyebolt Anchor
7	Cable Truss

Figure 33. Typical Cable Truss Assembly

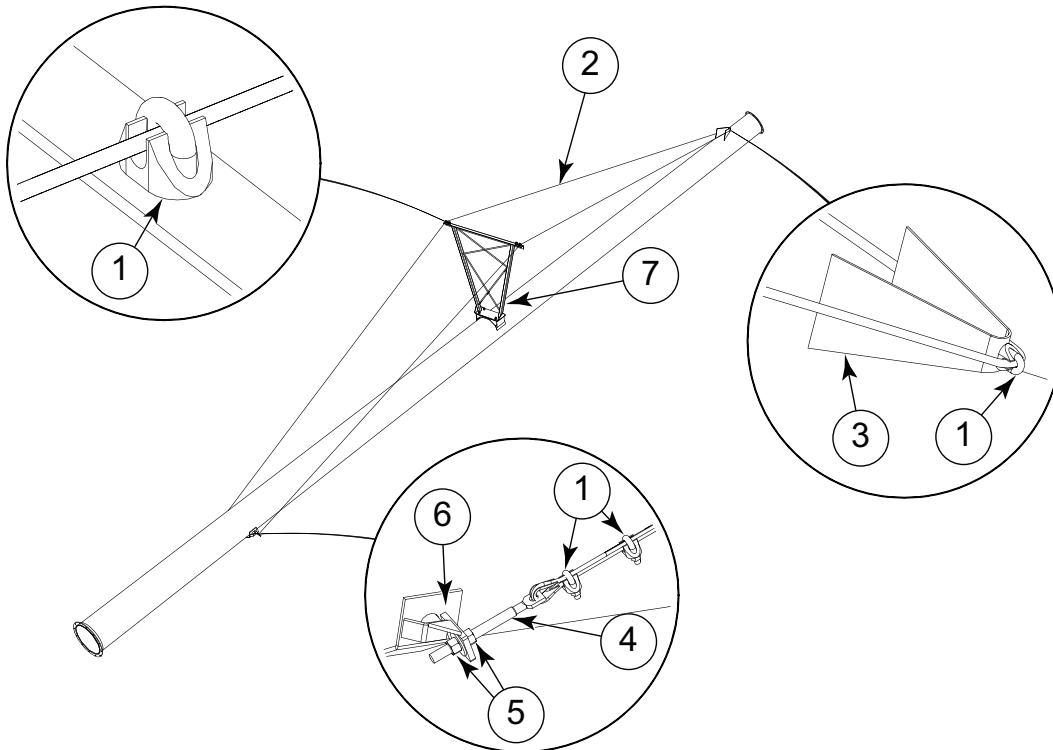

7.22. Pinion Gear Adjustment

➡ When Equipped:

The pinion gear should mesh with the ring gear to provide maximum tooth contact. If the pinion gear does not mesh entirely with the ring gear:

1. Adjust the handle slot bolt (which bolts to the drive mount clamp) so full meshing of the pinion gear is achieved when the handle is in the over-center position. The pinion gear will need adjustment when gear teeth bind or are not meshing sufficiently.
 - **Gear teeth binding:** If the handle will not lock into over-center position, loosen the slot bolt nuts and slide the handle away from the tire.
 - **Insufficient Meshing:** If the pinion gear will barely mesh with the ring gear, loosen the slot bolt jam nuts and slide the handle towards the tire until the pinion gear teeth mesh with the ring gear teeth without binding.

Figure 34. Pinion Gear Adjustment Nut

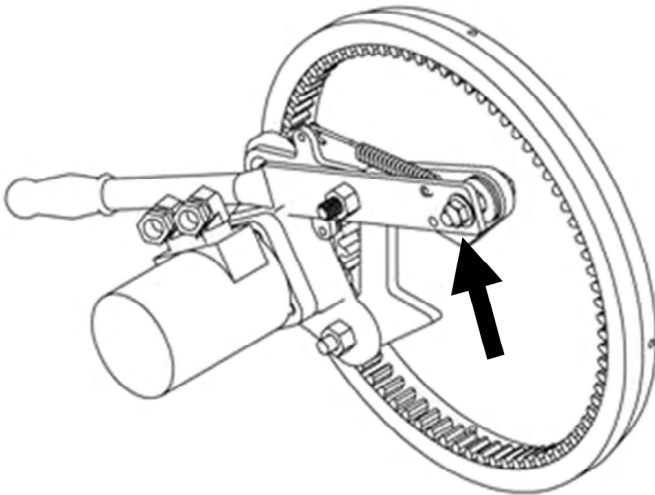

8. Troubleshooting

⚠ WARNING Shut down and lock out all power sources before diagnosing any of the causes or attempting any of the solutions below.

In the following section, we have listed some causes and solutions to some of the problems you may encounter.

If you encounter a problem that is difficult to solve, even after having read through this section, please contact your local dealer or distributor. Before you contact them, please have this operation manual and the serial number from your machine ready.

Conveyor

Problem	Cause	Solution
Low conveying capacity.	Conveyor angle is too high.	Re-position with lower tube angle, see Operation.
	Incorrect belt speed.	Verify and adjust belt speed to appropriate speed, see Belt Speed in Operation.
	Conveyor belt slipping.	Tighten conveyor belt, see Conveyor Belt Tension in Maintenance.
	When Equipped: Drive belts slipping.	Tighten belts, see Drive Belt Tension in Maintenance.
Low capacity for some grains.	Smaller and smoother grains will slide at shallower angles.	Reduce conveyor height, see Conveyor Operating Angles in Operation.
Conveyor belt slipping.	Conveying belt loose.	Tighten and align belt, see Belt Tension and Belt Alignment in Maintenance.
	Drive roller lagging worn or damaged.	Replace drive roller lagging, see dealer.
	When Equipped: Drive belts loose.	Tighten belts, see Drive Belt Tension in Maintenance.
	Belt frozen to tube from operating in high humidity in cold conditions.	Remove conveyor from area of high humidity and warm belt to de-ice.
Excessive conveyor belt edge fraying.	Belt not aligned.	Align belt, see Belt Alignment in Maintenance.
Conveyor belt loose.	Belt stretches over time.	Re-tension belt, see Belt Tension in Maintenance.



		If belt is fully tensioned, you may need to shorten belt and re-lace, see Belt Relacing in Maintenance.
Grain leaking from conveyor hopper.	Belt not aligned (centered).	Align belt, see Belt Alignment in Maintenance.
	Flashing installed incorrectly or worn.	Inspect flashing for wear and replace if required.
	Hopper cloth worn or damaged.	Replace damaged hopper cloth.
	When equipped: Transition filler rings are worn.	Replace transition filler rings.
Hopper cloth collapsing under grain.	Misaligned or broken spring (s).	Check spring installation and repair as required.
	Pivot shafts improperly installed.	On some machines, switching pivot shafts left to right will increase hopper tension.
Grain leaking from conveyor discharge between belt and tube.	Belt not aligned (centered).	Align belt, see Belt Alignment in Maintenance.
Grain leaking from conveyor discharge between hood and belt.	Belt speed is too fast, hood plugging.	Decrease belt speed, see Belt Speed in Operation.
U-clamps or brackets sliding on tube.	U-clamps or brackets not properly crimped to tube.	Contact dealer or Batco to correct positioning.

Drive

Problem	Cause	Solution
Drive making noise.	When Equipped: Slipping drive belt.	Tighten belts, see Drive Belt Tension in Maintenance.
	Hot shaft, pulley or bearing.	Overheated components indicate a failed bearing that must be repaired.
	Broken drive roller.	Replace damaged component.

Scissor Lift Hydraulics (when equipped)

Problem	Cause	Solution
Valve is leaking.	Loose/cracked fittings.	Tighten/replace fittings.
	Worn hose.	Replace hose.
	Valve spools are worn.	Replace valve.
Machine operates slowly.	Oil is hot.	Check oil level and add if required.
	Blockage in hydraulic lines.	Suction hose blocked or kinked.
	Power source is not producing enough oil volume and/or pressure.	Speed up the engine to produce more flow/pressure The power unit may not have enough capacity to operate properly.
Hydraulic cylinder leaking.	Worn seal.	Replace seal.

Mover Kit with Scissor Lift Conveyor **(when equipped)**

Problem	Cause	Solution
Valve is leaking.	Loose/cracked fittings.	Tighten/replace fittings.
	Worn hose.	Replace hose.
	Valve spools are worn.	Replace valve.
Machine operates slowly.	Oil is hot.	Check oil level and add oil if required (use general purpose ISO 32 hydraulic oil).
	Blockage in hydraulic lines.	Suction hose blocked or kinked.
	Power source is not producing enough oil volume and/or pressure.	Speed up the engine to produce more flow/pressure The power unit may not have enough capacity to operate properly.
	Cushion block needs adjusting.	Adjust valve on cushion block by turning inward 1/8 of a turn at a time, refer to Ram and Travel Speed.
	Filter plugged (if equipped).	Change filter.
Hydraulic cylinder leaking.	Worn seal.	Replace seal.



Conveyor doesn't drive.	Cushion block needs adjusting.	Adjust needle valve by turning clockwise 1/8 of a turn - try and repeat if necessary, refer to Ram and Travel Speed.
Pinion gear slipping or binding.	Pinion gear not adjusted properly.	Adjust the pinion gear. See Pinion Gear Adjustment.

9. Specifications

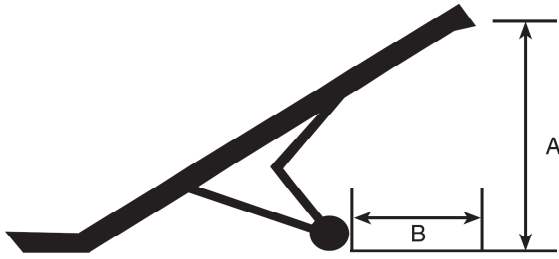

Model	Belt Length	Weight (lbs)	Up-Operation		Down - Transport		Width (ft)	HP PTO	HP ELEC	HP GAS	HP HYD. (Cu.in.)
			A (ft)	B (ft)	A (ft)	B (ft)					
1555	115'3"	2354	26.3	22.2	14.9	23.6	9	30 HP	10 HP	27 HP	N/A
1565	135'6"	2997	31.4	22.4	11.6	26.1	11	30 HP	15 HP	27 HP	N/A
1575	155'	3252	36.6	30.9	12.6	36.2	11	40 HP	20 HP	27 HP	N/A
1585	175'	3734	41.7	35.2	14.2	41.7	11.3	40 HP	20 HP	35 HP	N/A
1590	185'	3850	44.2	39.5	14.9	46.7	11.3	50 HP	25 HP	35 HP	N/A
15100	205'	4450	49	39.7	13.5	48.3	11.3	50 HP	25 HP	35 HP	N/A
1835	73'9"	2246	15.5	15.5	11	17.1	7.5	25 HP	10 HP	N/A	N/A
1845	93'9"	2532	21.1	18	12.5	22	7.5	30 HP	10 HP	N/A	N/A
1855	113'9"	3076	26.1	23	15.4	24.3	10.3	40 HP	15 HP	N/A	N/A
2035	77'10"	2765	16.1	16.9	10.7	17.4	7.5	40 HP	15 HP	N/A	N/A
2045	97'10"	3098	20.8	21.4	13	22.7	7.5	40 HP	15 HP	N/A	N/A
2055	117'10"	3650	26.1	24.7	13.8	24	10.3	50 HP	20 HP	N/A	N/A
2065	137'10"	4826	31.1	22.3	12.2	25.3	*11.6	60 HP	25 HP	N/A	N/A
2075	157'10"	5126	36.3	31.1	13.7	35.3	*11.6	60 HP	30 HP	N/A	N/A
2085	177'10"	5868	40.7	32.1	12.7	38.1	*11.6	70 HP	30 HP	N/A	N/A
2095	197'10"	6127	46.4	40.7	14.4	48	*11.6	80 HP	40 HP	N/A	N/A
20105	217'10"	7990	51.1	N/A	15.9	N/A	**13.92	80 HP	40 HP	N/A	N/A
20110	227'10"	8800	54	N/A	17.1	N/A	**13.92	90 HP	50 HP	N/A	N/A
20120	247'10"	9430	58.6	N/A	17.4	N/A	**13.92	100 HP	50 HP	N/A	N/A
2465	141'2"	5081	32.1	23.4	12.5	26	*11.6	60 HP	25 HP	N/A	N/A
2475	161'2"	5396	36.1	32	14.3	35.8	*11.6	70 HP	30 HP	N/A	N/A
2485	181'2"	6153	42.3	32.6	13.7	38.6	*11.6	80 HP	30 HP	N/A	N/A
2495	201'2"	6630	47.1	41.5	14.9	48.5	*11.6	80 HP	40 HP	N/A	N/A
24105	221'2"	8305	52.5	N/A	16.3	N/A	**13.92	90 HP	40 HP	N/A	N/A



Model	Belt Length	Weight (lbs)	Up-Operation		Down - Transport		Width (ft)	HP PTO	HP ELEC	HP GAS	HP HYD. (Cu.in.)
			A (ft)	B (ft)	A (ft)	B (ft)					
24110	231'2"	9495	53.9	N/A	17.1	N/A	**13.92	100 HP	50 HP	N/A	N/A
24120	251'2"	9770	60	N/A	18.4	N/A	**13.92	120 HP	50 HP	N/A	N/A

* Extends out to 14.8'

** Extends out to 16.63'

10. AGI Swift Current Limited Warranty

This warranty relates to Belt Conveyors (the “Product”) sold by Batco-Rem, (a division of Ag Growth International Inc., referred to herein as the “Seller”) and applies only to the first user of the Product (meaning a purchaser directly from the Seller or from an authorized dealer or distributor of the Product, referred to herein as the “Buyer”).

This warranty shall only be effective if properly registered with the Seller in accordance with information provided to the Buyer at the time of sale.

1. The Seller warrants to the Buyer that the Product is free from defects in material and workmanship **under normal and reasonable use** and in accordance with manufacturer’s manual.
2. This warranty applies only to defects in materials and workmanship and not to damage incurred in shipping or handling, through normal wear and tear, or damage due to causes beyond the control of the Seller such as lightning, fire, flood, wind, earthquake, excessive voltage, mechanical shock, water damage, or damage arising out of abuse, alteration, improper assembly, improper installation, improper maintenance or improper repair of the Product.
3. **The warranty period for the Product shall be two years from delivery of the Product to the Buyer where the Product is used in a normal farm operation. First year of warranty coverage of parts and repair labour, second year warranty coverage of parts only. Warranty period for the Product shall be 90 days from delivery of the Product to the Buyer where the Product is used in a commercial operation. No warranty is given where the Product was used to convey canola.** In the event that any part incorporated into the Product is manufactured and sold to the Seller by a third party vendor, such part is only warranted to the extent of the warranty given by that third party.
4. This warranty does not obligate the Seller to bear costs of travel in replacing defective parts.
5. The obligations set forth in this warranty are conditional upon the Buyer promptly notifying the Seller of any defect and completing reasonably required documentation and, if required, promptly making the Product available for correction.
6. The total liability of the Seller on any claim, whether in contract, tort or otherwise, arising out of, connected with, or resulting from the manufacture, sale, delivery, repair, replacement or use of the Product or any part thereof **shall not exceed the price paid for the Product** and the Seller shall not be liable for any special indirect, incidental or consequential damages caused by reason of the installation, modification, use, repair, maintenance or mechanical failure of the Product. **Consequential or special damages as used herein include, but are not limited to, lost or damaged products or goods, costs of transportation, lost sales, lost orders, lost income, increased overhead, labor and incidental costs and operational inefficiencies.**
7. The foregoing warranty is the entire warranty of the Seller to the Buyer and the Buyer shall not be entitled to rely upon any representation or warranty contained in any marketing material of the Seller in respect of the Product. The Seller neither assumes, nor authorizes any other person purporting to act on its behalf to modify or to change this warranty, nor to assume for it any other warranty or liability concerning the Product.

WARRANTY VOID IF NOT REGISTERED





Shipping: 201 Industrial Drive, Swift Current, Saskatchewan S9H 5R4, CANADA

Mailing: Box 1750, Swift Current, Saskatchewan S9H 4J8, CANADA

Toll-Free: (877) 667-7421 (Canada & USA)

Phone: (306) 773-7779

Fax: (306) 778-2524

Web: www.batcomfg.com

Email: info@batcomfg.com

©Ag Growth International Inc. 2018

Printed in Canada
