

FUEL-VAULT®

RECTANGULAR CONTAINED TANKS

AGI WESTEEL

ULC S601/S602 - 1,100 L TO 5,000 L

The Fuel-Vault® rectangular contained is engineered to store flammable and combustible liquids such as gasoline (ULC S601 only), diesel, solvents or paint products. Easy to use and install, the double wall containment provides protection against costly and environmentally damaging leaks or ruptures. Best of all, it is manufactured by AGI Westeel to meet or exceed all national regulations and to provide years of worry free service.

FEATURES

- » Durable all steel double wall construction in a compact low profile design
- » Large spillbox with removable bottom access plate and a lockable weatherproof cover
- » Weather and corrosion resistant white powder coat finish on exterior
- » Space between the inner and outer tank with a port to check for any fluid release from the primary tank
- » Easy attachment to auxiliary equipment

ACCORDANCE COMPLIANCE

- » CAN/ULC S601 (RFV2400 through RFV5000 only)

TYPICAL APPLICATIONS

- » Vehicle and equipment maintenance
- » Oil and gas facilities
- » Manufacturing facilities
- » Agricultural facilities

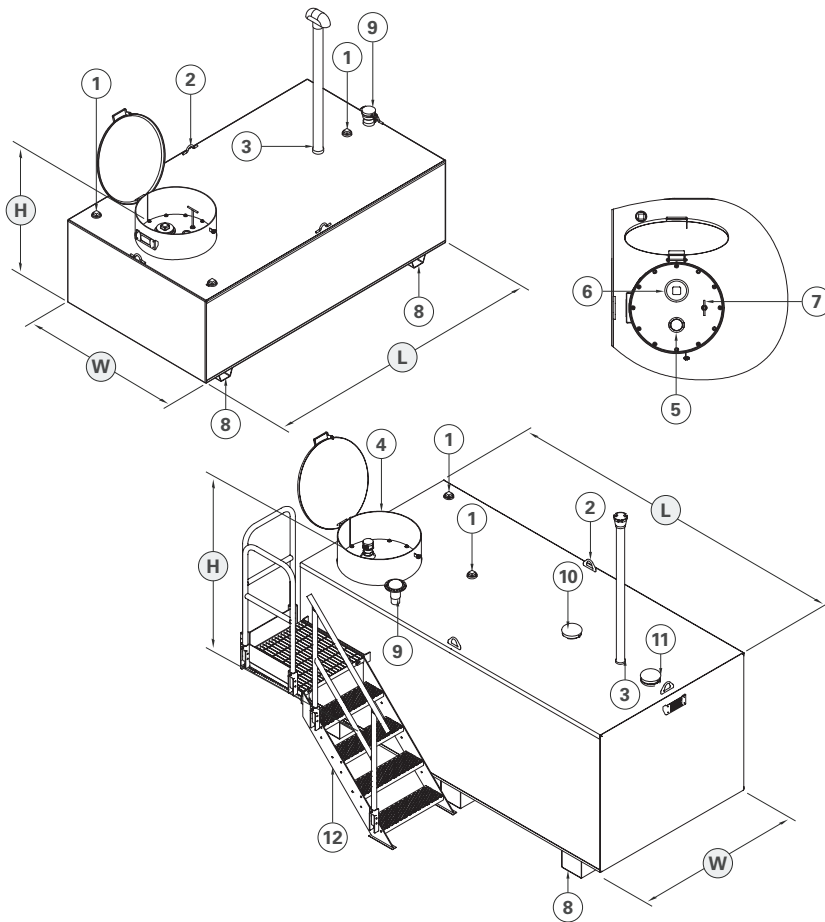

TANK LAYOUT

- | | | |
|---|----------------------------|--|
| 1. 2" NPT - spare port | 3. 2" camlock and dust cap | 10. Primary emergency vent |
| 2. Lift lugs | 4. 4" fill port | 11. Secondary emergency vent |
| 3. Primary tank normal vent port (stack & vent cap shipped loose) | 7. Spill box drain plug | 12. 12. Stair assembly (RFV5000 only)* |
| 4. 24" spillbox (fill, gauge, drain) | 8. Support legs | |
| | 9. Inspection/vent port | |

* optional equipment

SPECIFICATIONS

MODEL NUMBER	PRIMARY TANK CAPACITY			WIDTH W		LENGTH L		HEIGHT H		WEIGHT	
	IMP GAL	US GAL	L	IN	MM	IN	MM	IN	MM	LB	KG
RFV1100	250	300	1135	49	1235	75	1916	36	925	791	360
RFV2400	529	635	2400	58	1466	101	2573	43	1082	1244	565
RFV2499	550	661	2499	40	1018	81	2061	66	1682	1212	551
RFV5000	1101	1323	5000	61	1542	122	3103	63	1598	2456	1116



Consistent with AGI Westeel policy of continued research and development of our products, we reserve the right to modify or change information contained in this publication without notice. 1015-100

WESTEEL is an AGI Brand.

AGI is a leading provider of equipment solutions for agriculture bulk commodities including seed, fertilizer, grain, and feed systems with a growing platform in providing equipment and solutions for food processing facilities. AGI has manufacturing facilities in Canada, the United States, the United Kingdom, Brazil, India and Italy and distributes its products globally.

AGI WESTEEL