

DUST COLLECTION CYCLONES



Dust Collection Cyclones

Custom Engineered For Maximum Efficiency

Economical AGI AIRLANCO Cyclones come in three models designated HE, HV, and RC. They operate without any filter media to clean or replace and are custom-made for their intended applications. AGI AIRLANCO manufactures Cyclones in carbon or stainless steel with round or square inlets and supply a variety of ancillary components, such as duct work, fans, airlocks and other equipment to provide complete integrated systems.



HE Series Cyclones provide high efficiency separation of dust and particulates from plant and process air. They can withstand high temperatures, moisture content and airflow. HE Cyclones are sometimes used as pre-filters to remove large, hot or moist particles that may damage filter media in other types of collectors. Their size is limited for maximum efficiency; consequently, HE Cyclones are often ganged to meet the demands of rather large air volumes.

HV Series Cyclones are built to handle very large air volumes. They are designed for outdoor installations where physical size is unrestricted. These units normally serve as primary receivers at processing plants where they separate material from process air.



Rotatable Draw-Thru can be positioned for convenient clean air orientation.

Involute Inlet runs 180° around the Cyclone to optimize cyclonic action inside the unit so that dust particles are forced against the outside wall where inertia and gravity can separate them from the airstream.

Inner Riser Tube directs the ascending secondary vortex to the draw-thru during the final phase of particle separation.

Flanged Construction and lifting lugs facilitate on-site assembly.

Hopper Cone features an 8" diameter bolted inspection door. Standard hopper slope is 75° to ensure proper particle flow. If the diameter of the discharge is nonstandard, the hopper height will change to maintain the slope.

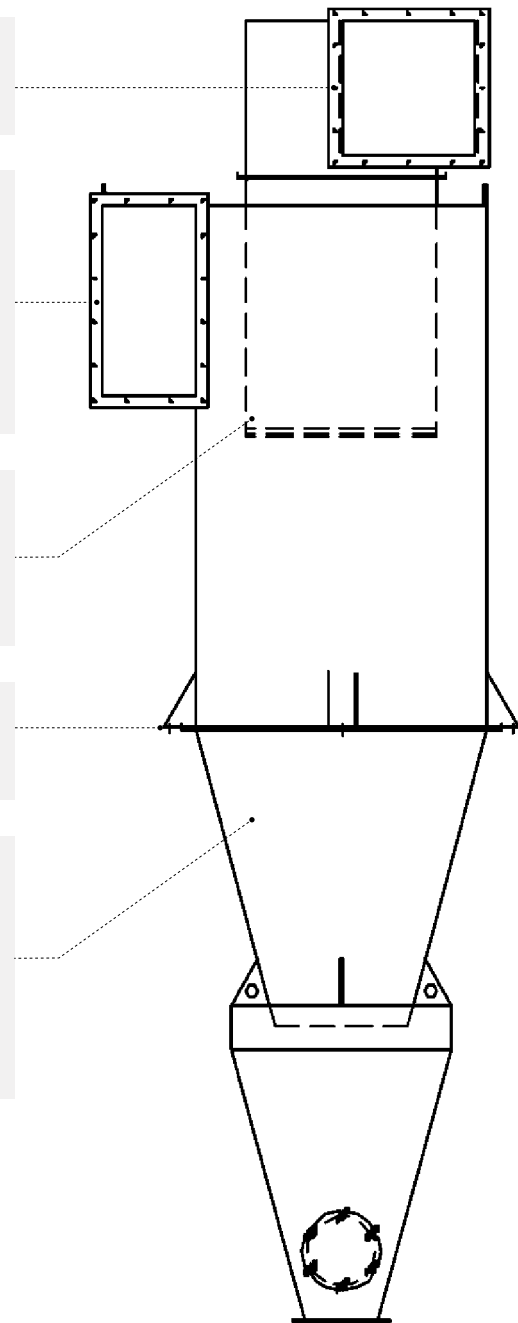

Heavy-Duty Support Structure (not shown) ensures stability.

RC Series Cyclones are typically used as primary receivers for dry bulk solids in our pneumatic conveying systems.

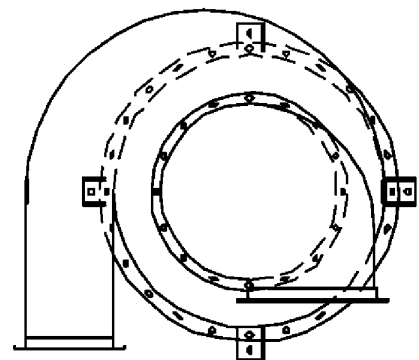



AIRLANCO is an AGI Brand.

AGI is a leading provider of equipment solutions for agriculture bulk commodities including seed, fertilizer, grain, and feed systems with a growing platform in providing equipment and solutions for food processing facilities. AGI has manufacturing facilities in Canada, the United States, the United Kingdom, Brazil, India and Italy and distributes its products globally.

AGI **AIRLANCO**

312 South Highway 73, PO BOX 398 Falls City, Nebraska USA 68355
 1.800.500.9777 | sales@airlanco.com | aggrowth.com/airlanco

AGGROWTH.COM [aggrowthintl](#) [▶](#) [▶](#) [▶](#) [▶](#) [▶](#) [▶](#)