

15' – 36' Commercial Hopper Tank Series

Wide-Corr® Centurion® Grain Bin Installation and Storage Instructions

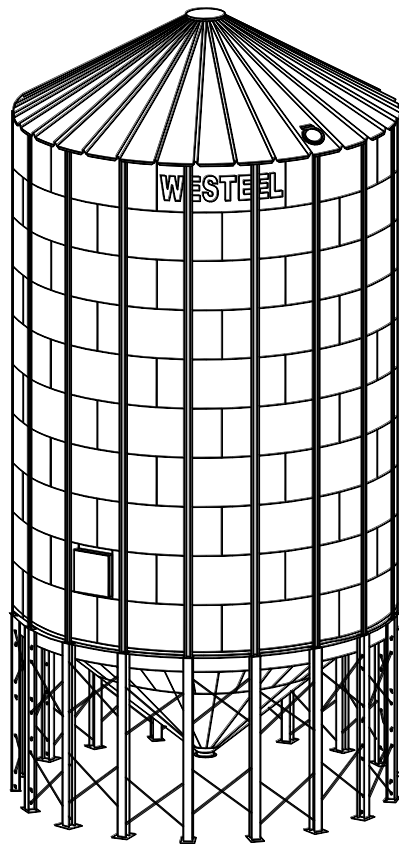

Read this manual before using product. Failure to follow instructions and safety precautions can result in serious injury, death, or property damage. Keep manual for future reference.

Part Number: 198824 R35

Revised: February 2022

Original Instructions

New in this Manual

The following changes have been made in this revision of the manual:

Description	Section
Added Roof Rib and Roof Rib Cap Installation in Typical Non-Structural Roof Installation	Install the Roof Rib Caps on page 40
Updated Roof Ladder Details	Section 5.9 – Roof Ladder Details on page 48
Added Rib Cap Quantities	Section 7.2 – Rib Cap Quantities on page 77
Updated Roof Hardware Table	Table 20 on page 82

CONTENTS

1. Introduction	5
2. Safety.....	6
2.1 Safety Alert Symbol and Signal Words.....	6
2.2 General Safety Information.....	6
2.3 Personal Protective Equipment.....	7
2.4 Safety Decals	7
2.5 Decal Installation/Replacement	7
2.6 Safety Decal Locations and Details	8
3. Before You Begin	11
3.1 Bin Design and Capacity.....	11
3.1.1 Roof Design Capacities for Non-Structural Roofs.....	12
3.1.2 Roof Design Capacities for Structural Roofs.....	13
3.1.3 Roof Snow Load vs. Ground Snow Load	13
3.2 Foundation Design and Loads	14
3.3 Site and Assembly	14
3.4 Methods of Installation	14
3.5 Cutting Openings in Wide-Corr® Grain Bins	15
3.6 Critical Assembly Requirements	16
3.7 Product Storage.....	17
3.8 Grain Bin Use.....	18
3.9 Important Notes.....	18
4. Preparation	20
4.1 Check Shipment.....	20
4.2 List of Tools and Equipment.....	20
4.3 Order Optional Equipment.....	20
5. Assembly	21
5.1 Assembly Safety	21
5.2 Anchor Bolt Layout.....	22
5.3 Bottom Flange Detail.....	23
5.4 Hopper Assembly	24
5.5 Compression Ring and Support Assembly Details	29
5.6 Connection Detail for 36' Upper Hopper Sheets	31
5.7 Commercial Hopper Flashing Instructions.....	32
5.8 Typical Non-Structural Roof Installation	33
5.9 Roof Ladder Details	48
5.10 Flat Roof Cap Assembly.....	49
5.11 Inspection Hatch Details	50
5.12 Inspection Hatch Reinforcing Plate	51
5.13 Bin Entry Anchor System: Non-Structured Roof.....	52
5.14 Wall Sheets.....	54
5.15 Centurion Wall Sheet Part Number Matrix	55
5.16 One-Tier Light Duty Door (15' – 27') Installation.....	56
5.17 One-Tier Light Duty Door Installation.....	57
5.18 One-Tier Medium Duty Door Installation	58
5.19 Wall Sheet Caulking Detail	59
5.20 Commercial Bin Upright Assembly.....	61

5.20.1 Base Assembly.....	67
5.21 Wind Ring Assembly.....	68
5.22 Bin Jack Techniques.....	70
6. Specifications	72
6.1 Wide-Corr® Hopper Tank Specifications	72
7. Appendix	75
7.1 Roof Parts Box Listing.....	75
7.2 Rib Cap Quantities.....	77
7.3 Roof Parts Box Part Identification.....	78
7.4 Hardware Usage	82
7.5 Recommended Bolt Assembly	87
8. Limited Warranty: Westeel Grain Bin Products	88

1. Introduction

Before assembling, please read this manual. Familiarize yourself with the process and the necessary precautions for efficient and safe assembly of this Westeel 15' – 36' Commercial Hopper Tank Series.

Everyone present at the assembly site is required to be familiar with all safety precautions.

Keep this manual available for frequent reference and review it with new personnel. Call your local distributor or dealer if you need assistance or additional information.

2. Safety

2.1. Safety Alert Symbol and Signal Words



This safety alert symbol indicates important safety messages in this manual. When you see this symbol, be alert to the possibility of injury or death, carefully read the message that follows, and inform others.

Signal Words: Note the use of the signal words **DANGER**, **WARNING**, **CAUTION**, and **NOTICE** with the safety messages. The appropriate signal word for each message has been selected using the definitions below as a guideline.



Indicates an imminently hazardous situation that, if not avoided, will result in serious injury or death.



Indicates a hazardous situation that, if not avoided, could result in serious injury or death.



Indicates a hazardous situation that, if not avoided, may result in minor or moderate injury.



Indicates a potentially hazardous situation that, if not avoided, may result in property damage.

2.2. General Safety Information

Read and understand all safety instructions, safety decals, and manuals and follow them when assembling the equipment.

- Only experienced personnel who are familiar with this type of assembly and installation should perform this work. Untrained assemblers/installers expose themselves and bystanders to possible serious injury or death.
- Do not modify the grain bin in any way or deviate from the instructions in this manual without written permission from the manufacturer. Unauthorized modification or methods may impair the function and/or safety. Any unauthorized modification will void the warranty.
- Follow a health and safety program for your worksite. Contact your local occupational health and safety organization for information.
- Contact your local representative or Westeel if you need assistance or additional information.
- Always follow applicable local codes and regulations.



2.3. Personal Protective Equipment

The following Personal Protective Equipment (PPE) should be worn when installing the equipment.

Safety Glasses

- Wear safety glasses at all times to protect eyes from debris.

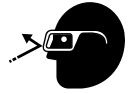

Coveralls

- Wear coveralls to protect skin.



Hard Hat

- Wear a hard hat to help protect your head.



Steel-Toe Boots

- Wear steel-toe boots to protect feet from falling debris.



Work Gloves

- Wear work gloves to protect your hands from sharp and rough edges.



2.4. Safety Decals

- Keep safety decals clean and legible at all times.
- Replace safety decals that are missing or have become illegible. See decal location figures that follow.
- Replaced parts must display the same decal(s) as the original part.
- Replacement safety decals are available **free of charge** from your distributor, dealer, or factory as applicable.

2.5. Decal Installation/Replacement



1. Decal area must be clean and dry, with a temperature above 50°F (10°C).
2. Decide on the exact position before you remove the backing paper.
3. Align the decal over the specified area and carefully press the small portion with the exposed sticky backing in place.
4. Slowly peel back the remaining paper and carefully smooth the remaining portion of the decal in place.
5. Small air pockets can be pierced with a pin and smoothed out using the decal backing paper.

2.6. Safety Decal Locations and Details

Replicas of the safety decals that are attached to the grain bin and their messages are shown in the figure(s) that follow. Safe operation and use of the grain bin requires that you familiarize yourself with the various safety decals and the areas or particular functions that the decals apply to, as well as the safety precautions that must be taken to avoid serious injury, death, or damage.

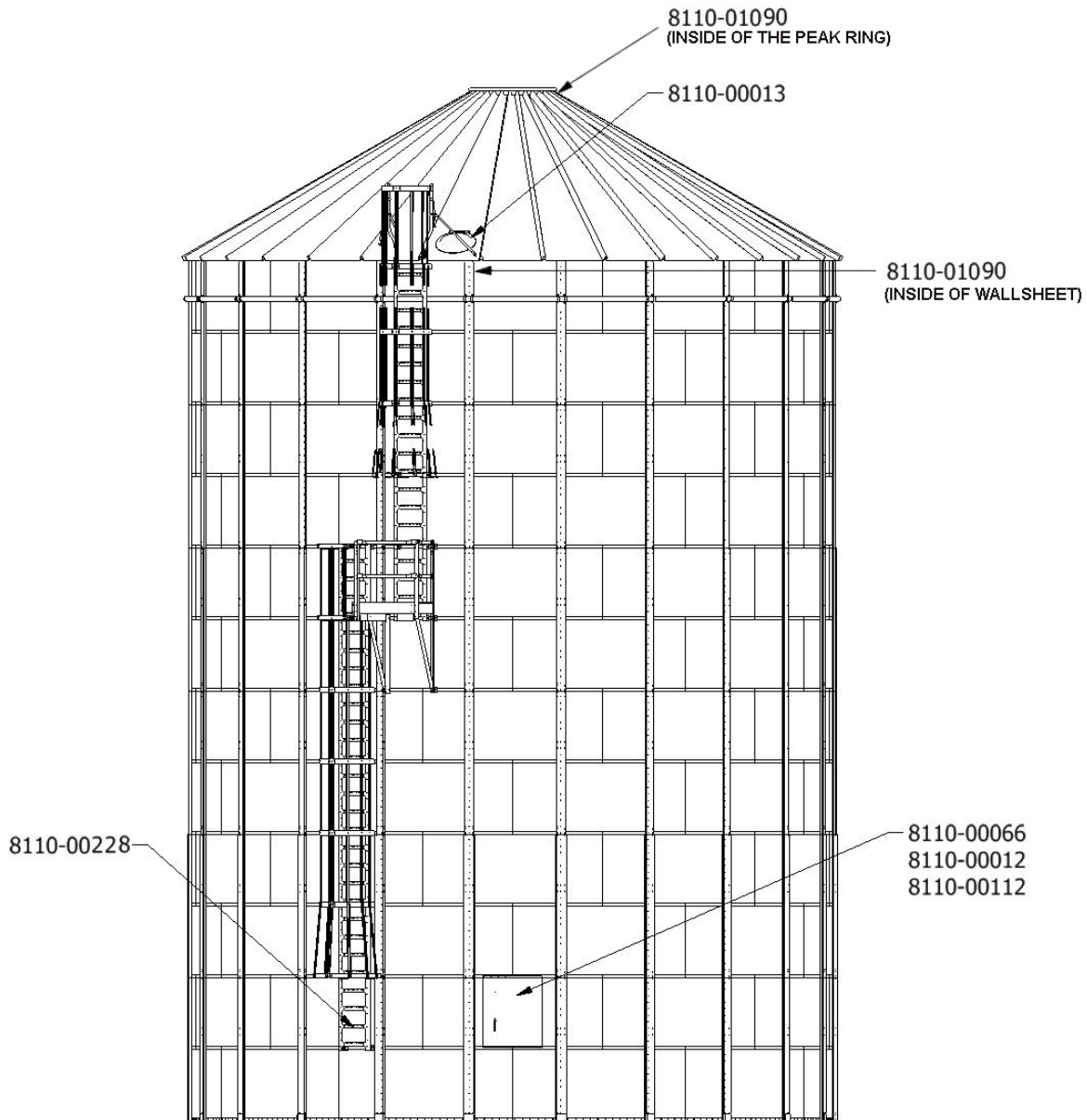
Figure 1. Safety Decals







 WARNING	
	
SAFETY INSTRUCTIONS	
<ul style="list-style-type: none"> • Read operator's manual and all safety decals before assembling, using, or servicing bin. • Close/latch all access doors when not in use. • Do not alter or modify bin structure. • Replace any damaged components only with factory made components. • This bin should only be used to store free flowing, granular material, unless specifically designed and marked otherwise. • When filling, use top filler cap and direct material to center of bin. • Do not over-fill bin. Material should not be in contact with or place pressure on roof sheets. 	

Part Number: 8110-00012

 WARNING	
	
ENTRAPMENT HAZARD	
<p>Never enter the bin when loading or unloading grain.</p> <p>If you must enter the bin:</p> <ol style="list-style-type: none"> 1. Shut off and lock out all power. 2. Use a lifeline, safety harness, and have an observer outside before entering the bin. 3. Wear proper breathing equipment or a respirator. 4. Avoid the center of the bin. <p>Failure to heed these warnings could result in serious injury or death.</p>	

Part Number: 8110-00013

 WARNING		
		
Rotating flighting could kill or dismember.	Flowing material could trap and suffocate.	Crusted material could collapse and suffocate.
Keep clear of all augers. DO NOT ENTER this bin!		
<p>If you must enter the bin:</p> <ol style="list-style-type: none"> 1. Shut off and lock out all power. 2. Use a safety harness and safety line. 3. Station another person outside the bin. 4. Avoid the center of the bin. 5. Wear proper breathing equipment or respirator. <p>Failure to heed these warnings could result in serious injury or death.</p>		

Part Number: 8110-00112

WARNING



FALLING HAZARD

To prevent serious injury or death:

- Do not climb ladder if damaged, wet, icy, greasy, or slippery.
- Maintain good balance by having at least three points of contact at all times. Face the ladder while climbing.
- Safe working load is 350 lb (160 kg). Do not overload.
- Do not carry items while climbing.

Part Number: 8110-00228

NOTICE

When equipped with aeration system, to prevent roof and/or bin damage:

- Use a minimum 1 square foot (0.1m²) opening for each 1000ft³/min (30m³/min) of air.
- Ensure all roof vents are open and unobstructed.
- Discontinue use of aeration fan if roof vents become obstructed with ice.

Part Number: 8110-00066



**FALL RESTRAINT
ANCHOR POINT
MAX WORKING LOAD:
1,000 lb [453 kg]**

SEE MANUFACTURER ROOF MANUAL FOR
DETAILED INSTRUCTIONS REGARDING
ANCHOR POINT LOCATIONS

Part Number: 8110-01090

3. Before You Begin

3.1. Bin Design and Capacity

Standard Westeel Grain Bins are designed for:

1. Non-corrosive free-flowing materials up to 55 lbs/ft³ (880 kg/m³) average compacted bulk density.
2. Maximum horizontal wind pressure based on 94 mph (151 km/h) as per NBCC 2015 and 105 mph (169 km/h) as per ASCE 7-16.
3. Zero seismic activity.

Note

Seismic resistance in grain bins varies with height and diameter. Many standard designs have significant seismic capabilities. Designs can be reviewed and/or modified to reflect local seismic requirements.

4. Roof loading capabilities vary with diameter, peak load and snow load.
 - a. Peak Loads – standard peak loads follow. **Upgrades are available.**

Table 1. Peak Loads for Various Roofs

Size	Type of Roof	Load (lbs)	Load (kg)
15' to 24'	non-structural	4000 lbs	1814 kg
27' to 48'	non-structural	5000 lbs	2268 kg
51' & 54'	non-structural	8000 lbs	3629 kg
48' to 108'	structural	20,000 lbs	9072 kg

- b. Roof Snow Loads (RSL) – at the above stated standard peak loads, standard RSLs vary with diameter and range from 16 psf (78 kg/m²) to 45 psf (220 kg/m²). **Upgrades are available.**

Note

The correlation between ground snow load (GSL) and roof snow load (RSL) for grain bin designs vary with jurisdictions. In the US $GSL = 2 \times RSL$. In Europe $GSL = 1.25 \times RSL$. In Canada the correlation between GSL and RSL varies and is site specific.

- c. For maximum roof snow load capacities for various sizes and types of roofs, refer to the Roof Design Capacities sections that follow.

3.1.1 Roof Design Capacities for Non-Structural Roofs

Table 2. Maximum Roof Snow Load at STANDARD Peak Load

Bin Series	Std Peak Load	Standard Roof		Plus Upgrade 1		Plus Upgrade 2	
	lbs (kN)	psf	kPa	psf	kPa	psf	kPa
15	4000 (17.8)	45	2.15	n/a		n/a	
16		45	2.15				
18		45	2.15				
21		30	1.44	49	2.35		
24		21	1.01	40	1.92		
27		24	1.15	39	1.87		
30	5000 (22.2)	20	0.96	32	1.53	40	1.92
33		23	1.10	33	1.58	44	2.11
36		24	1.15	30	1.44	38	1.82
39		22	1.05	27	1.29	36	1.72
42		19	0.91	24	1.15	34	1.63
45		16	0.77	23	1.10	32	1.53
48		21	1.01	26	1.24	33	1.58
51		8000 (35.6)	20	0.96	28	1.34	n/a
54	17		0.81	27	1.29		

Table 3. Maximum Roof Snow Load at UPGRADED Peak Load

Bin Series	Upgraded Peak Load	Standard Roof		Plus Upgrade 1		Plus Upgrade 2			
	lbs (kN)	psf	kPa	psf	kPa	psf	kPa		
15	8000 (35.6)	29	1.39	n/a		n/a			
16		29	1.39						
18		29	1.39						
21		24	1.15	40	1.92				
24		17	0.81	27	1.29				
27	10000 (44.5)	19	0.91	28	1.34	n/a			
30		15	0.72	24	1.15			33	1.58
33		18	0.86	24	1.15			36	1.72
36		18	0.86	23	1.10			31	1.48
39		16	0.77	21	1.01			30	1.44
42		14	0.67	19	0.91			27	1.29
45		13	0.62	18	0.86			25	1.20
48*		16	0.77	21	1.01			26	1.24
51*	12000 (53.4)	14	0.67	21	1.01	n/a			
54*		13	0.62	20	0.96				

Note

- Standard roofs are adequate for many applications but additional capacity is available when optional upgrade packages are used.
- Upgrade packages include roof stiffening rings and/or rib supports.
- For peak load between standard and upgrade limits, a straight line interpolation can be used to determine maximum roof snow load.
- *Structural roofs for 48' – 54' with rafters are available to support peak ring loads greater than loads on [Table 3](#).
- Higher level upgrade kits include all components from lower level kit; only one upgrade kit needs to be ordered for any given bin.

3.1.2 Roof Design Capacities for Structural Roofs

Table 4. Maximum Roof Snow Load at STANDARD Peak Loads

Bin Series	Std Peak Load	Standard Roof	
	lbs (kN)	psf	kPa
48	20000 (89.0)	39	1.87
51		39	1.87
54		39	1.87
60		39	1.87
66		38	1.82
72		38	1.82
75		37	1.77
78		37	1.77
84		37	1.77
90		37	1.77
96		37	1.77
102		32	1.53
105		32	1.53
108		32	1.53

Table 5. Maximum Roof Snow Load at UPGRADED Peak Loads

Bin Series	Upgraded Peak Load	Standard Roof	
	lbs (kN)	psf	kPa
48	60000 (266.9)	38	1.82
51		38	1.82
54		38	1.82
60		38	1.82
66		37	1.77
72		37	1.77
75		36	1.72
78		36	1.72
84		36	1.72
90		34	1.63
96		34	1.63
102		31	1.48
105		31	1.48
108		31	1.48

Note

Standard capacities are provided. Additional capacity is available with optional upgrades.

3.1.3 Roof Snow Load vs. Ground Snow Load

The Roof Design Capacity tables reflect roof snow load (RSL) values. These are design values. Often, comparisons are made to ground snow values (GSL). These are not the same. The conversion from GSL to RSL varies between jurisdictions and is governed by building codes:

- In the United States, for grain bins, $GSL = RSL \times 2$
- In Europe, for grain bins, $GSL = RSL \times 1.25$

- In Canada, for grain bins, the GSL/RSL conversion varies with every location across the country. However, for comparison purposes, the US conversion can be used as an approximation.

Therefore, when comparing against competitive GSL values in the US, double the above values. When comparing against competitive GSL values in Canada, double the above values for a reasonably close approximation.

3.2. Foundation Design and Loads

The foundations for the stiffened bin models are based on 4000 lbs. per sq. ft. (192 kPa) soil bearing capacity. All foundation designs use 3000 lbs. per sq. in. (21 MPa) ultimate compressive strength (after 28 days) for concrete and 43,500 lbs. per sq. in. (300 MPa) re-bar. The foundation designs included in this manual are suggestions only, and will vary according to local soil conditions. Westeel will not assume any liability for results arising from their use.

Important

Foundation should be uniform and level. Level should not vary by more than ¼" over a span of four feet under the bottom ring angle. Any variance from level must be shimmed under upright base assembly. If being utilized to support a full floor aeration system, this levelness requirement should extend across the complete floor area.

3.3. Site and Assembly

Unless otherwise specifically provided in writing, Westeel does not take responsibility for any defects or damages to any property, or injury to any persons, arising from or related to any site or assembly considerations, including but not limited to:

- Bin location and bin siting
- Soil conditions and corresponding foundation requirements (Note that the examples provided in manuals are for specifically stated soil conditions.)
- Bin assembly (Westeel recommends the use of qualified bin installers). Contact Westeel for information on installers in your area.
- Field modifications or equipment additions that affect the bin structure
- Interconnections with neighboring structures
- Compliance with all applicable safety standards, including but not limited to fall restraint systems (ladders or other systems). Local safety authorities should be contacted as standards vary between jurisdictions.

3.4. Methods of Installation

The recommendations for assembling and installing Westeel grain bins must be closely followed to achieve the full strength of the bin and to achieve adequate weather sealing. The product warranty is void if:

1. Wall sheets and/or uprights not specified for a given tier are used.
2. Foundations are found to be inadequate or out-of-level.
3. Anchor bolts (cast-in-place, drill-in, chemical type or other) are found to be inadequate.
4. Off-center loading or unloading is used. (This does not apply to the use of approved side unloading systems).
5. Materials stored are not free-flowing or have a compacted bulk density greater than 55 lbs/ft³ (880 kg/m³).

If using bin jacks during assembly, always lift on an upright. Choose a hoist with an adequate capacity for the expected empty bin deadload. Make sure the rated capacity of the hoist is not exceeded.

3.5. Cutting Openings in Wide-Corr® Grain Bins

This section provides instructions for cutting openings to accommodate fan transitions, unloading augers and roof vents.

General Rules for Cutting openings

1. Never cut any uprights, roof ribs, or wall sheet bolted vertical seams to create an opening.
2. Openings shall be located so equipment being installed won't interfere with any bin components/accessories.
3. Openings shall be minimized as much as possible for structural integrity of grain bins.
4. Corners in openings shall be cut with minimum radius of 1/8" to reduce stress concentration.
5. Openings shall be sealed all the way around for all weather conditions.
6. Instructions shall be followed closely to avoid damage to bin structure.
7. Except cutting openings described below, any other modification to Westeel bins shall be approved by a professional engineer.

Openings for Fan Transitions of Aeration Floors

1. Consult aeration floor installation instructions for information on Planning floor layout.
2. Openings shall be centered to a wall sheet in horizontal direction.
3. Opening shall be cut as tight as it can be for the transition to go through and shall have no more than 1/4" gap on any side to the section of a fan transition going through a bin wall.
4. Opening height for fan transition shall be limited to 12.5" inches from bottom edge of a bottom wall sheet.
5. Opening width shall not exceed 46.5" for stiffened bins and 72.5" for unstiffened bins.
6. Vertical support shall be required to support load above opening.
7. Bottom angles may be cut flush to the sides of an opening to form part of opening.

Openings for Unloading Augers of Wide-Corr® Bins with Full Floor Aeration

1. Consult aeration floor installation instructions for information on Planning floor layout.
2. Openings shall be centered to a wall sheet in horizontal direction.

3. Openings shall be cut as tight as it can be for unloading auger to go through and shall have no more than 1/4" gap to auger flange section on any side.
4. Opening height for any auger shall be limited to 12.5" from the bottom edge of a bottom wall sheet.
5. Vertical flange of a bottom angle may be cut flush to sides of an opening to form part of opening.

Openings for Roof Vents in Roof Sheets

1. Openings shall be centered between roof ribs and have 2.5" minimum distance between edge of opening and base of a roof rib.
2. Openings can be square, rectangular, or round.
3. Openings shall be the same size as the inlet opening of a vent being installed.
4. Any side of a square/rectangular opening shall have a maximum length of 18" and a circular opening shall have a maximum diameter of 24".

3.6. Critical Assembly Requirements

To ensure a successful, safe and reliable outcome you must comply with the following assembly techniques and practices:

1. Comply with all local code and jurisdictional requirements applicable to your grain bin installation.
2. Design and build foundations with the necessary strength for the loads they must support, and for local soil conditions. Westeel foundation guidelines are based on specific stated conditions and may not be applicable to local conditions.
3. Your foundation must provide uniform and level support to the structure being supported. Surface imperfections causing gapping must be remedied. This may involve, but not be limited to a) grouting under the bottom ring of a non-stiffened bin or tank, and b) shimming under the uprights of a stiffened bin or tank, or under the legs of a hopper.
4. Make sure that the proper hardware is utilized for all bolted connections. If a shortage occurs, do not substitute. Take the necessary steps to obtain the proper hardware. Make sure nuts are tightened to the required torque values as specified in the appropriate assembly manual.
5. Comply with all assembly instructions provided in the appropriate assembly manual to make sure your whole grain bin is constructed safely. Important: Do not deviate from the wall sheet and upright layouts provided.
6. Before anchoring your structure to its foundation, make sure the structure is round. The maximum variation from perfect roundness is 3/4" on the radius. Locate anchor bolts toward the outside of the anchor bolt holes (away from the circle) to permit the incremental expansion that can occur with the initial filling.
7. When installing roof stiffening rings, if it is necessary to shorten the stiffening ring tubes, shorten them as little as possible. Initially the nuts on the expanders should be centered and as close together as possible. When tightening, share the amount of take-up between expanders such that the nuts remain centered, and the amount of engagement between all expanders on the same ring is equalized.
8. If extending an existing bin or tank, ensure that the foundation is adequate for the increased loads it must support.
9. If installing an existing bin on a hopper, make sure the bin is designed for a hopper application, and that the foundation is capable of withstanding the substantial point loads that the hopper legs apply. If uprights are present, make sure that they are supported.
10. Make sure that an integral end-to-end connection exists between all mating uprights. Successive uprights must not overlap.

11. Vertical tolerances between uprights and wall sheets are tight. This can be affected by “jacking” techniques, which can allow the tolerance to grow or shrink depending on the technique used. The gapping between successive uprights must be monitored to ensure that upright holes align with wall sheet holes.
12. If catwalks are being installed on the structure, upright catwalk upgrades are likely required. The upgraded stiffeners must be installed in the correct locations to support the intended catwalk loads. Also, the structure must be properly oriented to ensure the eventual correct alignment between the catwalks and the supporting uprights. Finally, the connectors that tie into the uprights and support the catwalks are best installed during assembly of the structure. See the catwalk assembly manual for additional details.

3.7. Product Storage

Rust on Galvanized Parts

1. White rust forms when moisture is allowed to collect on galvanized surfaces that have yet to develop the durable zinc oxide layer. This zinc oxide layer naturally occurs as the surface interacts with carbon dioxide, and is characterized over time by the dull grey appearance that weathered galvanized surfaces get.
2. Parts that are not well ventilated or well drained can collect water between surfaces and develop white rust.
3. White rust is not a structural concern if its development is stopped in the early stages. A light film or powdery residue can occur after a period of heavy rainfall or a short time of improper storage. If white rust has started to develop, separate parts and wipe off any moisture. Next, using a clean cloth, apply a thin layer of petroleum jelly or food-grade oil to the entire part.
4. If moisture is left on parts, this white rust can become more aggressive and turn into red rust. Red rust can cause degradation in the material and become a structural concern. Any parts that have red rust should be replaced immediately.

Storage Guidelines

- Keep all bundles dry before assembly of the bin.
- Start assembly as soon as possible.
- Do not lay bundles on the bare ground. Raise all bundles 6" to 8" off the ground on wood blocks or timbers. (See Detail A in [Figure 2 on page 17.](#))
- Store curved wall sheets ‘hump-up’. (See Detail A in [Figure 2 on page 17.](#))
- All other bundles material should be placed so they are well sloped to promote good drainage. (See Detail B in [Figure 2 on page 17.](#))
- Roof sheets must be elevated at least 12" at the small end of the sheets. (See Detail B in [Figure 2 on page 17.](#))
- Temporary storage can be provided by erecting a simple framework supporting a waterproof tarp. (See Detail C in [Figure 2 on page 17.](#))
- All bin boxes, ladder boxes and hardware boxes should be stored inside. These are not waterproof, and will deteriorate in normal weather conditions, allowing moisture to contact the parts inside.

Figure 2. Product Storage

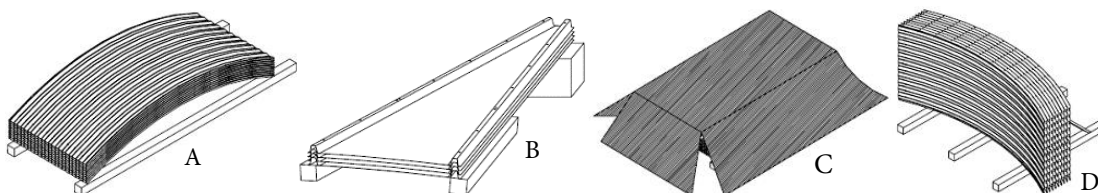

If Parts Become Wet

1. If parts become submerged or wet, the bundles should be opened as soon as possible, sheets or material separated and dried. Keep separated until assembly.

Brace parts properly so as to avoid damage or injury from material falling when in storage. (See Detail D in [Figure 2 on page 17.](#))

2. Any boxed parts that become wet should be dried and stored in a new box that is free of moisture.
3. In addition to wiping down wall sheets, a food-grade oil can also be applied with a clean, lint-free cloth. This will assist in preventing any further moisture from contacting the galvanizing on the steel. Due to safety concerns with installation and use, Westeel does not recommend the use of oil on other parts such as roof sheets and safety ladders.

3.8. Grain Bin Use

- Do not off-center unload a grain bin. It is imperative to unload from the center of the bin first, until as much grain as possible has been removed, and only then proceed to unload from the next closest unload gate to the center. Continue utilizing the unload gates in succession from the center towards the outside. Gate control mechanisms should be clearly marked and interconnected to prevent an external gate from being opened first.
- The only exception to center unloading is when a properly designed and installed side draw system is utilized. However, as bins tend to go out of round when employing side draws, the bin must be completely emptied before refilling.
- When unloading a bin with a mobile auger through a properly designed auger chute, the entry end of the auger should be pushed into the center of the bin before the auger is engaged. Slower rates of flow are preferable and should not exceed the capacity of an 8" auger.
- Ensure that the inner door panels of grain bin doors are completely closed and latched before filling the grain bin.
- Never enter a loaded grain bin for any reason. Grain can be a killer.

3.9. Important Notes

- Westeel does not provide a foundation design for this product, and is not liable for any damages or injuries related to inadequately designed or constructed foundations. Customers must contract professional services for all foundation design and construction work.
- In order to maintain your wall sheets in good condition separate sheets and allow air circulation between them. Store sheets in a dry place. Do not store sheets with sheet ends pointing upwards.
- To keep an even pressure on walls, the bin must always be unloaded from the center.
- Contact local power officials for minimum power line clearance.
- See [Section 3.6 – Critical Assembly Requirements on page 16](#) for mandatory siting and assembly requirements.
- Store only non-corrosive, free-flowing materials up to 55 lbs/ft³ (880 kg/m³) average compacted density in Westeel .
- Tighten all bolts to the recommended torque settings.
- Do not locate grain bins close to high buildings, which might cause snow to fall onto or build up on the roof of the grain bin. Consider future expansion and allow space for loading and unloading of the bin. Your dealer

and local government agricultural consultants can help you plan your storage system for maximum efficiency.

4. Preparation

4.1. Check Shipment

Unload the parts at the assembly site and compare the packing slip to the shipment. Ensure that all items have arrived and that none are damaged.

Report damaged parts or shortages immediately to your dealer. Your dealer will order replacement parts immediately to ensure that assembly will not be held up by missing parts. All parts will be charged for and credit will be issued by party at fault. No credit will be issued if freight bills are signed as received in good condition.

4.2. List of Tools and Equipment

Use quality tools and equipment. Use them safely, and correctly, for their intended use. Tools for this application should include:

Tools

- Electric or pneumatic (air) impact tools
- Power drill and drill bits
- Sockets (multiple 9/16" and 1/2" sockets recommended)
- Large-pocket carpenter pouch
- 8" (20 cm) metal punches (for aligning bolt holes)
- Step and extension ladders, construction grade
- 6-point wrenches (Imperial, box end)
- Metal-cutting saw suitable for cutting roof rings and wind rings
- Scaffolding
- Centre-post bin stand
- Crane and/or bin jacks

Minimum Recommended Safety Equipment

- A properly-stocked first-aid kit
- Eye, foot, head, and hand protection (safety glasses, steel-toed boots, hard hat, work gloves)
- Cable, chain, or rope to tie-off bin or jacks in case of wind
- Body harness and lifeline (for use where falling hazard exists)
- Ground fault interrupt protected electrical hook-ups

4.3. Order Optional Equipment

Optional equipment such as unloading augers, aeration equipment, anchor bolts, foundation sealant, external ladders, safety cage and platforms, etc., should all be on site and checked before assembly starts. Plan your installation in advance. For details, see assembly instruction supplied with optional equipment.

5. Assembly



Before continuing, ensure you have completely read and understood this manual's Safety section, in addition to the safety information in the section(s) below.

5.1. Assembly Safety

WARNING

- Do not take chances with safety. The components can be large, heavy, and hard to handle. Always use the proper tools, rated lifting equipment, and lifting points for the job.
- Carry out assembly in a large open area with a level surface.
- Always have two or more people assembling the grain bin.
- Make sure you have sufficient lighting for the work area.
- Tighten all fasteners according to their specifications. Do not replace or substitute bolts, nuts, or other hardware that is of lesser quality than the hardware supplied by the manufacturer.
- Stay away from overhead power lines and other obstructions during assembly. Contact with power lines can cause electrocution.
- Do not work in high winds.
- The equipment shall be installed in accordance with applicable local codes and regulations.

5.2. Anchor Bolt Layout

Figure 3. Anchor Bolt Layout

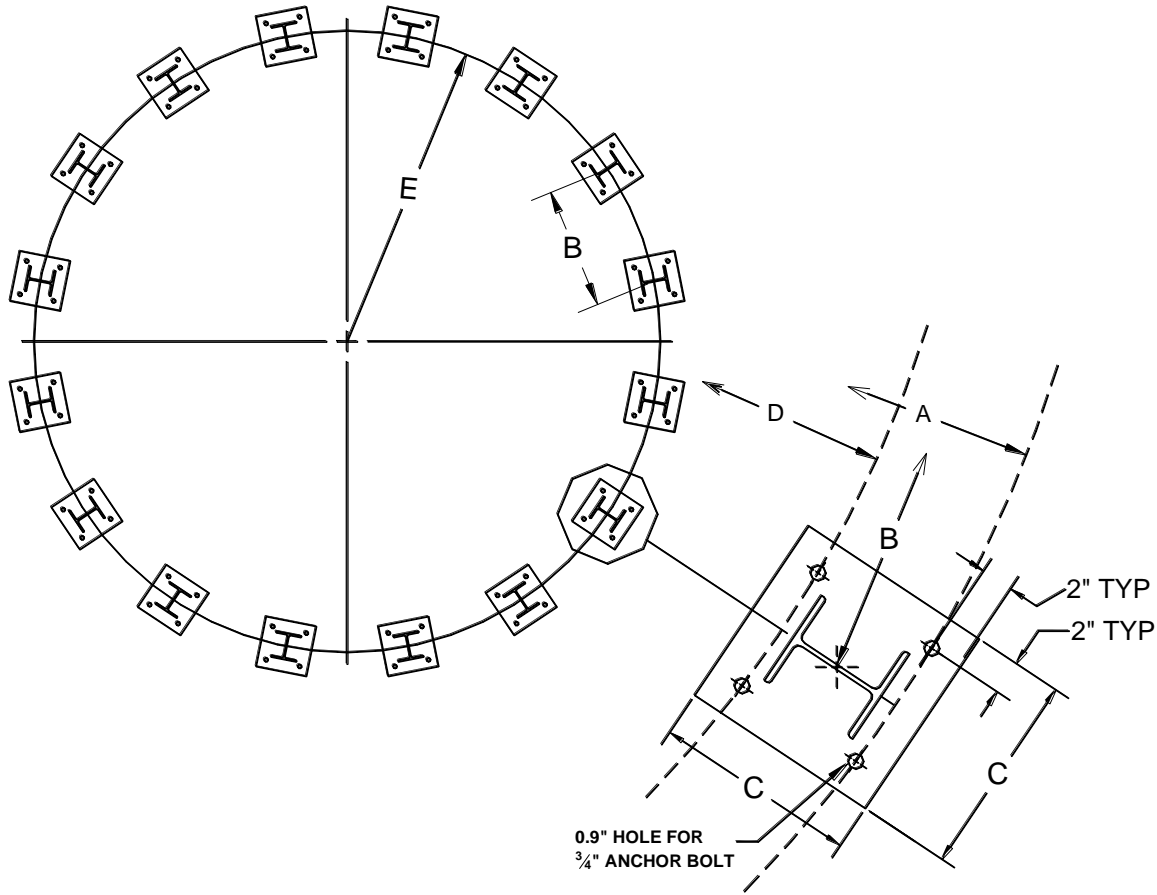

Tank Size	No. of Legs	Dimensions(inches)					No. of Anchor Bolts	Anchor Bolt Size (inches)	Non-factored Leg Loads (kips/leg)		
		A (Radius)	B	C	D (Radius)	E (Radius)			Vertical	Shear	Uplift
15	10	96.83	57.32	12	88.84	92.75	40	3/4	52	1.9	14.2
18	12	114.82	57.30	12	106.83	110.75	48	3/4	63	1.9	12.1
21	14	132.71	57.23	12	124.72	128.65	56	3/4	74	1.9	10.6
24	16	150.56	57.16	12	142.55	146.50	64	3/4	92	2.1	10.6
27	18	168.65	57.16	12	160.65	164.60	72	3/4	103	2.0	8.7
30	20	186.69	57.15	12	178.69	182.65	80	3/4	116	2.1	7.8
33	22	207.56	57.64	14	197.56	202.50	88	3/4	128	2.0	6.3
36	24	225.46	57.53	14	215.46	220.40	96	3/4	141	2.1	5.7

Legs loads are based on the following:

1. Non-corrosive, free-flowing materials up to 55 lbs/ft³ (880 kg/m³) bulk density
2. Maximum horizontal wind speed of 94 mph (151 km/h) = 24 lb/ft² (1.15 kPa) wind pressure
3. Maximum roof snow load of 24 lb/ft² (1.15 kPa)
4. Maximum roof cap load of 4,000 lbs (17.8 kN) for 15'-24' bins and 5,000 lbs (22.2 kN) for 27'-36' binsevenly distributed on peak ring
5. 15'-21' leg loads are for 13 tier tanks; 24'-36' leg loads are for 14 tier tanks

5.3. Bottom Flange Detail

14" diameter discharge cone

Figure 4. Detail of Bottom Flange of Discharge Cone

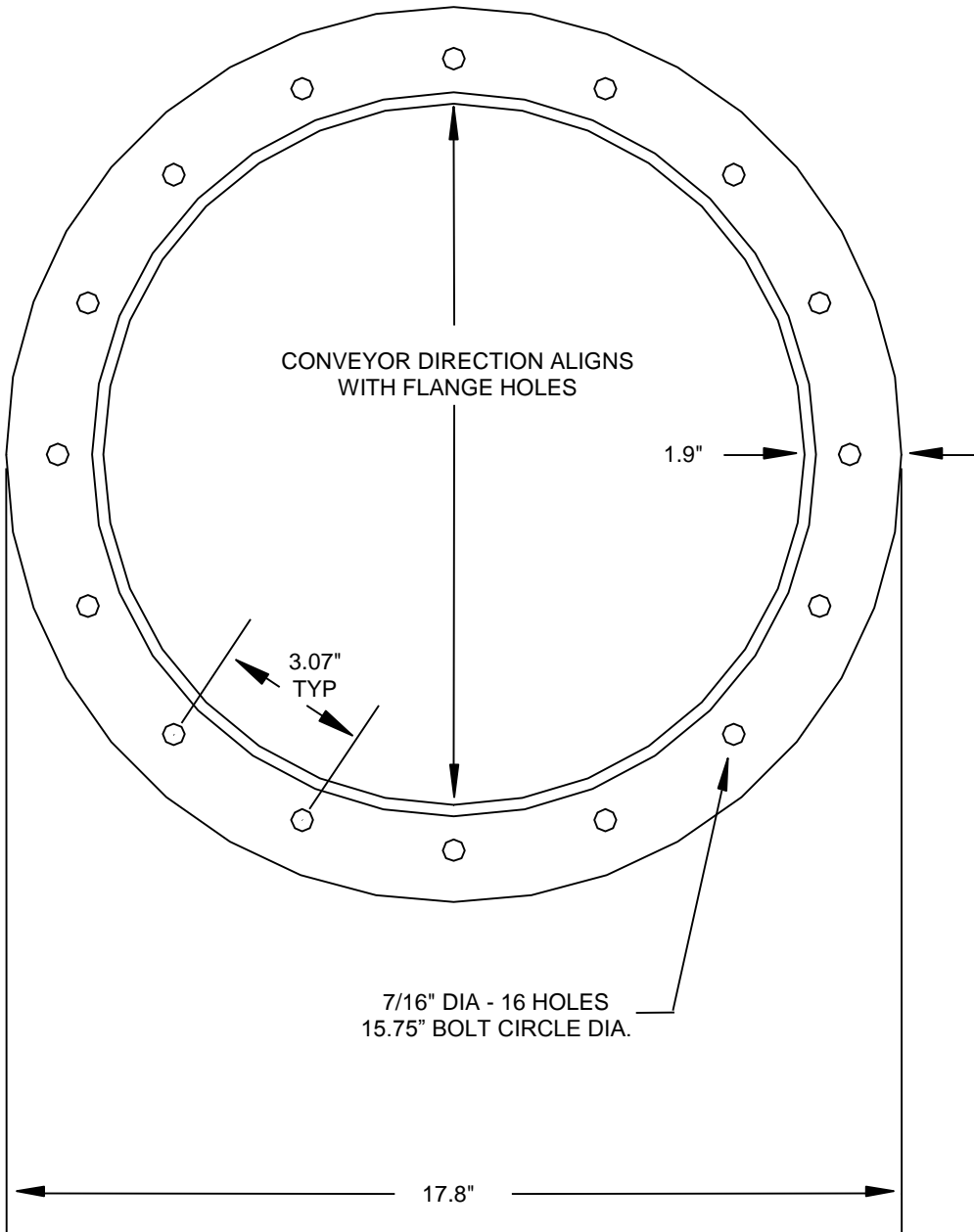

The 14" diameter discharge cone comes standard with all Wide-Corr® Commercial Hopper Tank Series bins. Other options are available at time of order, please contact Westeel in more information is needed.

5.4. Hopper Assembly

Assembly Instructions

1. Install the support columns, compression rings and tie rods.
2. Caulk the compression ring seams to prevent moisture penetration.

Important

Ensure that the complete support structure is circular before installing the hopper sheets. Sealing strip outside diameter should be as noted in Detail A or B. Measure the diameter at several locations.

3. Before lowering the bin onto the completed hopper structure, loosely attach the base assembly to the bottom upright.

Bolts in the vertical seam of the bottom wall sheets may have to be loosened or removed to facilitate connection to the compression ring.

Refer to the following pages for additional instructions, detail views and parts lists for various sizes of hoppers:

- [Assembling 15' and 18' Hoppers on page 25](#)
- [Assembling 21' and 24' Hoppers on page 26](#)
- [Assembling 27' and 30' Hoppers on page 27](#)
- [Assembling 33' and 36' Hoppers on page 28](#)

Assembling 15' and 18' Hoppers

Note

Ensure all bolts installed into hopper sheets are oriented so that the bolt head is on the inside of the hopper.

Figure 5. 15' and 18' Hoppers

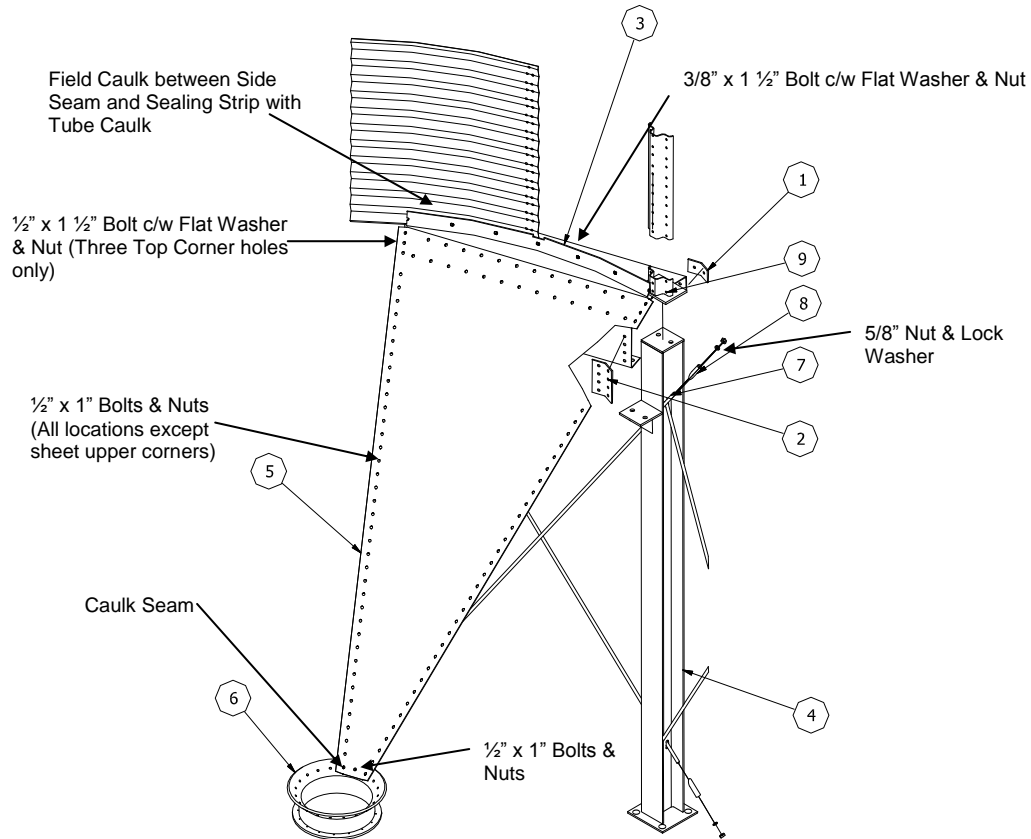

Table 6. 15' and 18' Hoppers Parts List

Item	Description	Series 15	Series 18
1	Splice Angle 3" x 6"	195290	195292
2	Splice Angle 6" x 8"	195291	195293
3	Compression Ring Assembly	195280	195282
4	Support Column Assembly	195300	195302
5	Hopper Sheet	197040	197041
6	Discharge Cone 14'	197046	197047
7	Tie Rod (15' = 112", 18' = 128")	195326	195328
8	Bevelled Tie Rod End	195313	195313
9	Upright Base Assembly	232777	232777

Assembling 21' and 24' Hoppers

Note

Ensure all bolts installed into hopper sheets are oriented so that the bolt head is on the inside of the hopper.

Figure 6. 21' and 24' Hoppers

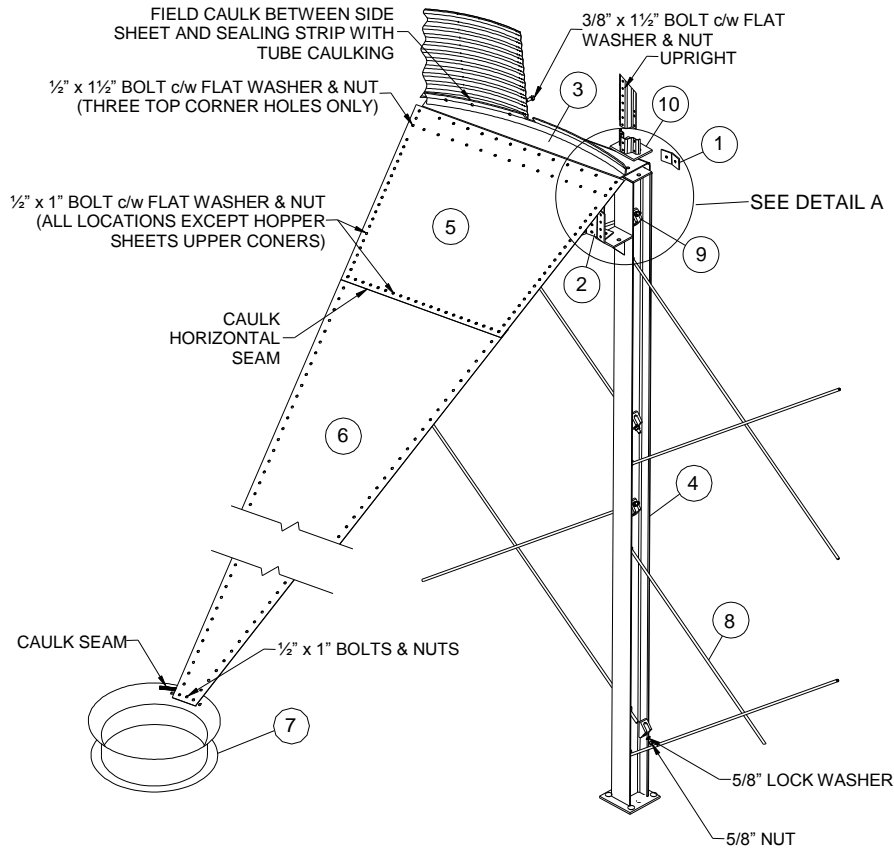

Table 7. 21' and 24' Hoppers Parts List

Item	Description	Series 21	Series 24
1	Splice Angle 3" x 6"	195294	195296
2	Splice Angle 6" x 8"	195295	195297
3	Compression Ring Assembly	195284	195286
4	Support Column Assembly	195304	195306
5	Upper Hopper Sheet	197042	197044
6	Lower Hopper Sheet	197043	197045
7	Discharge Cone 14'	197049	197052
8	Tie Rod (21' = 152", 24' = 89")	195312	195314
9	Bevelled Tie Rod End	195313	195315
10	Upright Base Assembly	232777	232777

Assembling 27' and 30' Hoppers

Note

Ensure all bolts installed into hopper sheets are oriented so that the bolt head is on the inside of the hopper.

Note

Column assemblies are not symmetrical - locate the top plate so that 3" dimension faces toward inside (see Detail B).

Figure 7. 27' and 30' Hoppers

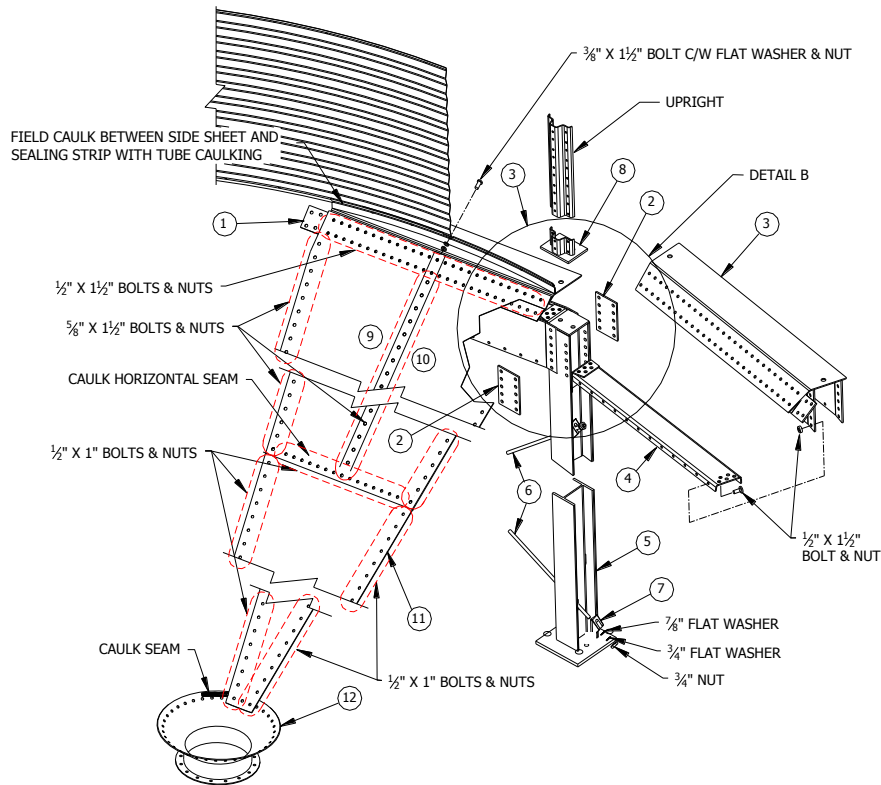
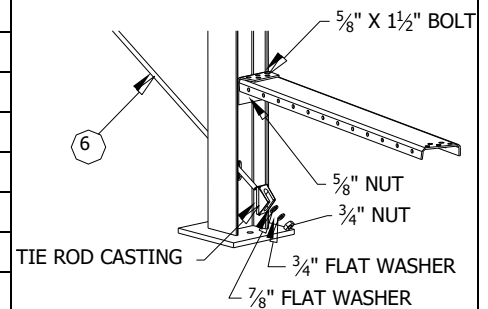

Table 8. 27' and 30' Hoppers Parts List

Item	Description	Series 27	Series 30
1	Splice Angle 5" x 10"	195378	195358
2	Splice Angle 6" x 10"	195346	195346
3	Compression Ring Assembly	195360	195338
4	Upper Channel	195365	195345
5	Support Column Assembly	195370	195348
6	Tie Rod 79"	195349	195349
7	Tie Rod Casting	193807	193807
8	Upright Base Assembly	232777	232777
9/10	Upper Hopper Sheet L & R	195375/6	195355/6
11	Lower Hopper Sheet	195377	195357
12	Discharge Cone 14"	197056	197060

**Figure 8. Model 3014 ONLY
Installation of lower compression
ring channel**



Assembling 33' and 36' Hoppers

Note

Ensure all bolts installed into hopper sheets are oriented so that the bolt head is on the inside of the hopper.

Note

Column assemblies are not symmetrical - locate the top plate so that 3" dimension faces toward inside (see Detail B).

Figure 9. 33' and 36' Hoppers

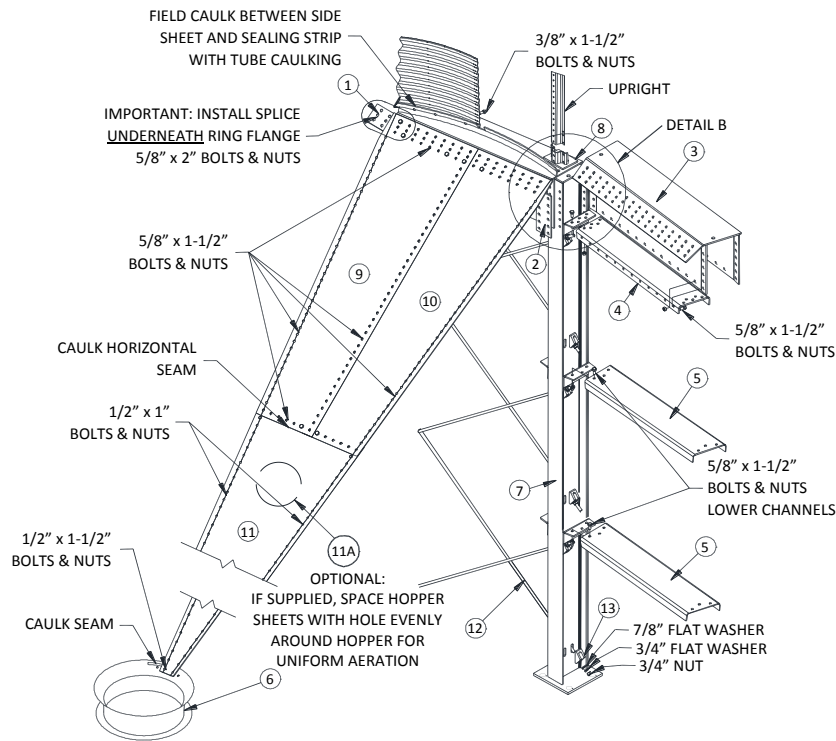
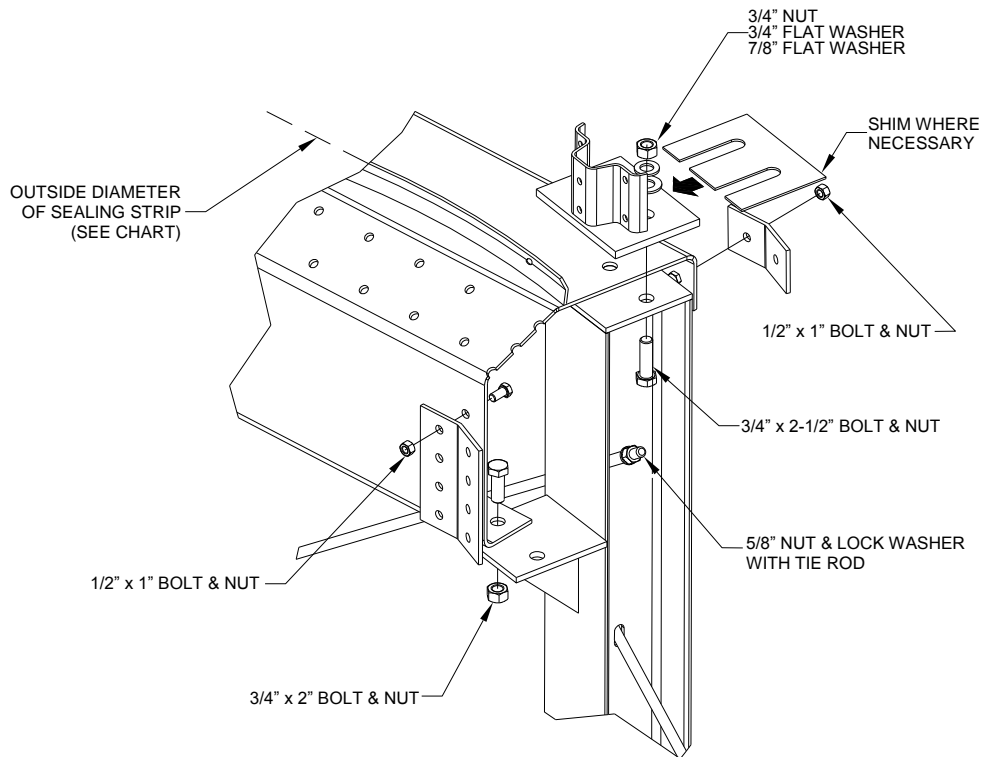

Table 9. 33' and 36' Hoppers Parts List

Item	Description	Series 33	Series 36
1	Splice Angle 6" x 15"	197015	197015
2	Splice Angle 6" x 15"	197014	197014
3	Compression Ring Assembly	197032	197007
4	Upper Channel	197012	197012
5	Lower Channel	197013	197013
6	Discharge Cone 14"	197025	197020
7	Support Column Assembly	197030	197001
8	Upright Base Assembly	232777	232777
9/10	Upper Hopper Sheet L & R	197035/6	197017/8
11	Lower Hopper Sheet	197037	197019
11A	Aeration Hopper Sheet c/w Hole	197037AER	197019AER
12	Tie Rod 79"	195349	195349
13	Tie Rod Casting	193807	193807

5.5. Compression Ring and Support Assembly Details

Figure 10. Detail A — Series 15 — 24



Bin Series	O/S Dia. of Sealing Strip (in)
15'	178.5 ± 1.0
18'	214.3 ± 1.0
21'	250.1 ± 1.0
24'	285.1 ± 1.0

Figure 11. Detail B — Series 27 — 36

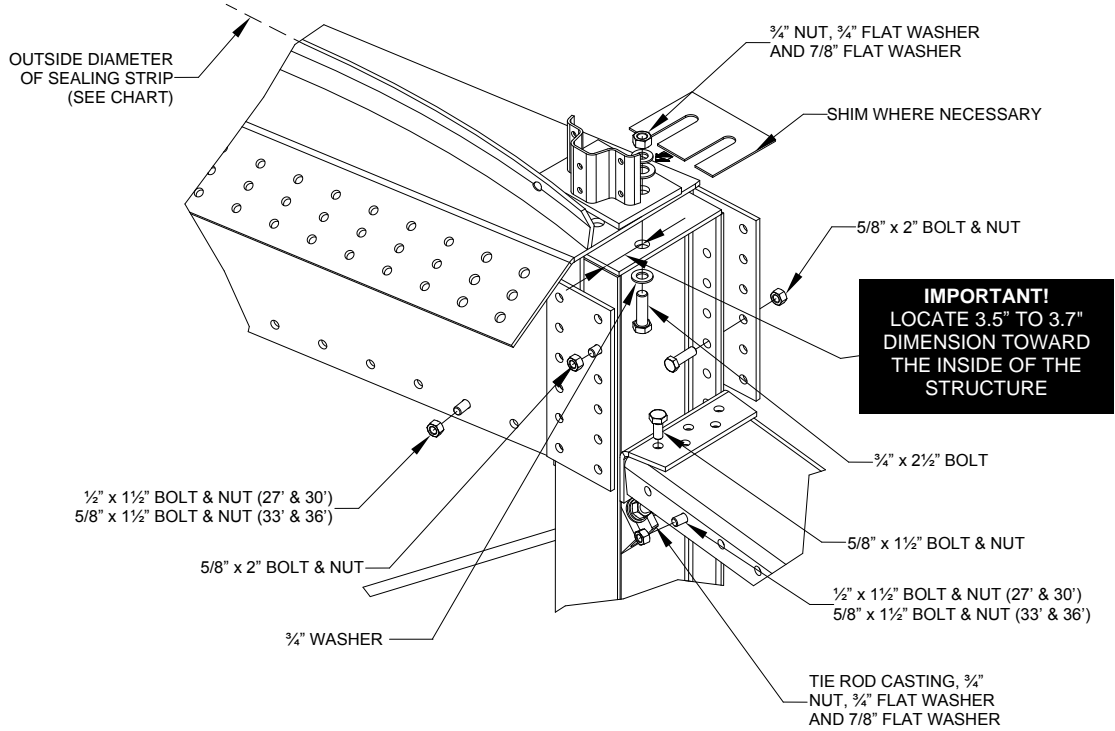

Bin Series	O/S Dia. of Sealing Strip (in)
27'	321.7 ± 1.0
30'	357.5 ± 1.0
33'	393.0 ± 1.0
36'	429.1 ± 1.0

5.6. Connection Detail for 36' Upper Hopper Sheets

Figure 12. Connection Detail for 36' Upper Hopper Sheets

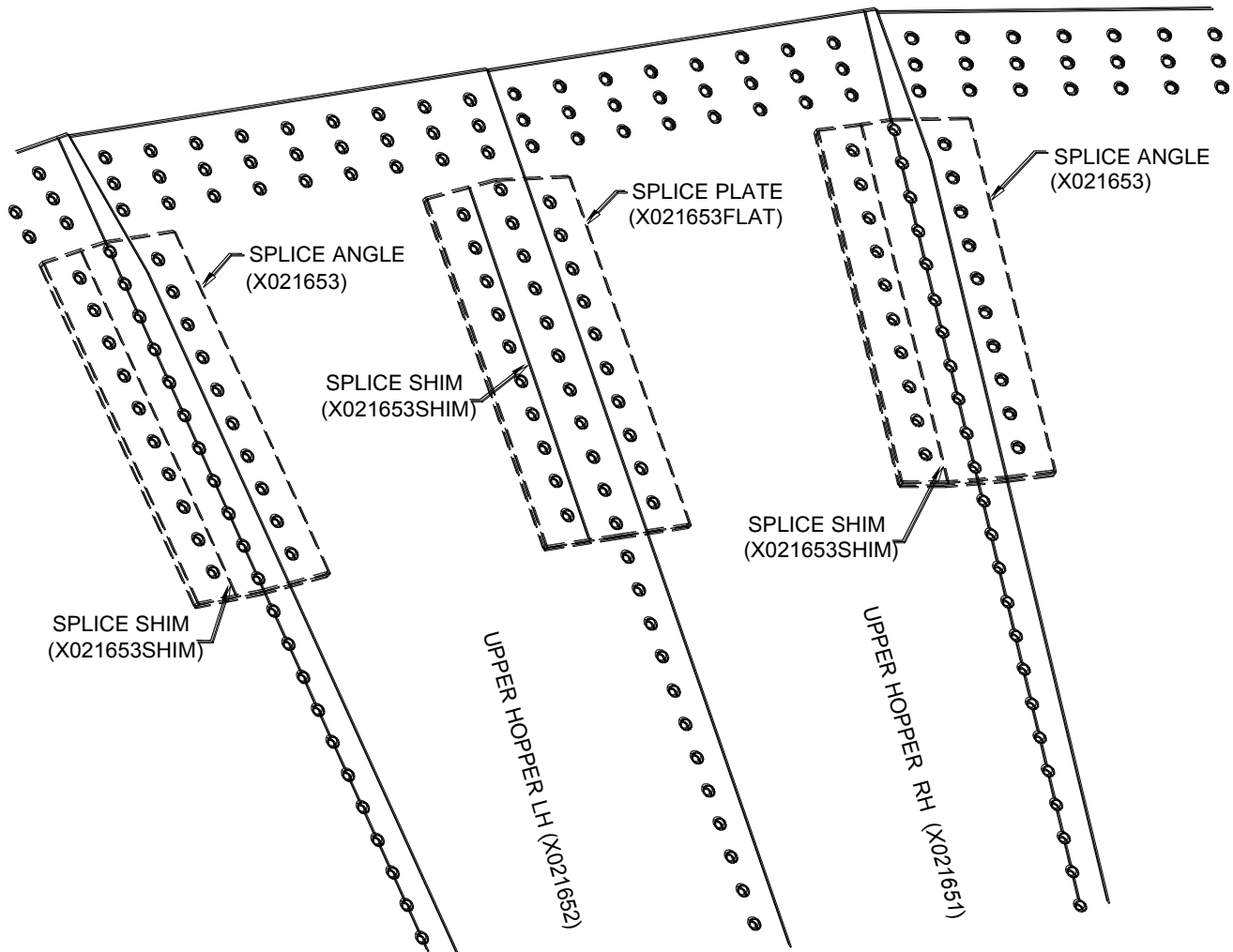

- Shims are used between splice and hopper sheet (one side only) to all for thickness of overlapping hopper sheet
- Splices and shims are installed **under** the hopper sheets
- Each 36' hopper uses:
 - 24 splice angles
 - 24 splice plates
 - 48 shims

5.7. Commercial Hopper Flashing Instructions

Figure 13. Commercial Hopper Flashing Assembly

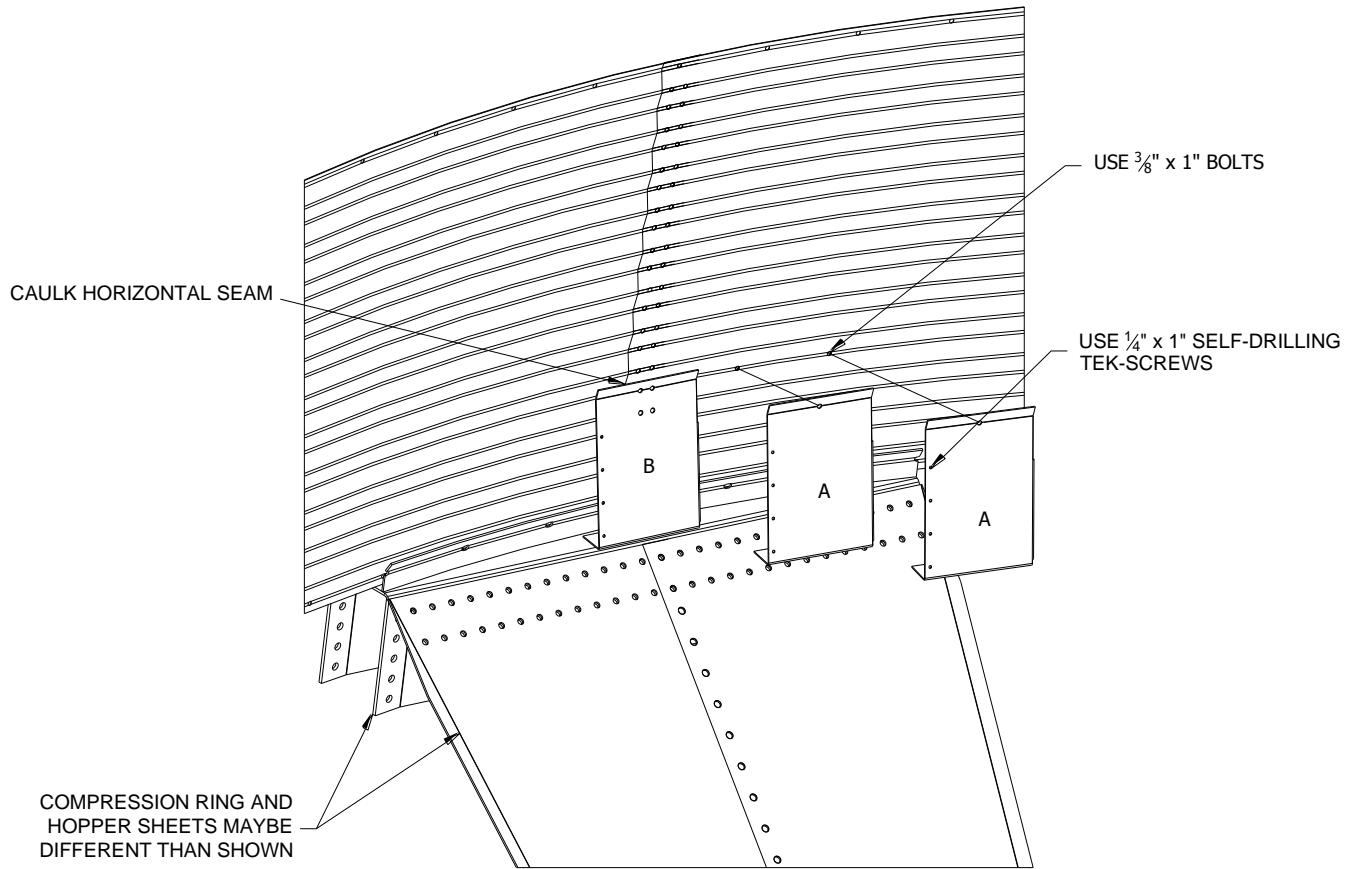

1. After the bin wall is bolted to the hopper compression ring, install the hopper flashing (019450) to the bottom wall sheet as shown in [Figure 13 on page 32](#).

For each wall sheet, 12 pieces of flashing are required. 11 pcs (A) have 1 hole at the top and 1 pce (B) has 4holes at the top. The B flashing is for use at the vertical wall seam.

2. Install 3/8" x 1' bolts in the horizontal row of holes, 12 3/4" from the bottom of the wall sheet.
3. Caulk the horizontal seam on the flashing panel to ensure the seal.
4. Place the next panel, working in a clockwise pattern. Fasten using 1/4" x 1" self drilling TEK screws.
5. Caulk the vertical seams, if required.

5.8. Typical Non-Structural Roof Installation

The following is a step-by-step procedure for assembling a non-structural roof system.

Preparation

1. Inspect the concrete foundation to insure that the foundation meets all the requirements of the installation.
2. Plan the assembly:
 - a. Determine the desired bin orientation.
 - b. Determine the locations of bin features and accessories (Westeel logo, fall restraint brackets, Grain Gauge, unloading devices, outside ladder, spiral stairs).

These considerations affect the location of the inspection hatch roof panel and the placement of the roof ladder or roof stairs.

3. Prepare the peak ring:
 - a. Install the supplied bulb gasket around the top of the peak ring. Trim to fit.
 - b. Install the foam closure gasket around the center section of the peak ring. Trim to fit.

Refer to [Figure 14 on page 33](#).

Figure 14. Gasket and Foam Closure Assembly to Peak Ring

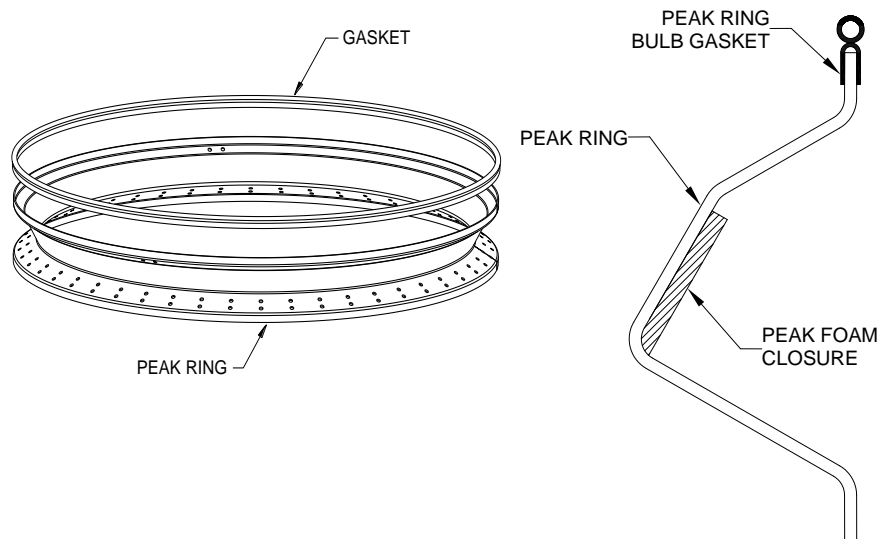

4. Install the center post making sure the post is vertical, braced and anchored properly for safe installation.
5. Lay out the bin circumference (for the bottom tier of wall sheets) on the foundation:
 - a. Anchor a string to the exact center of the concrete foundation.
 - b. Determine the required string length using [Table 10 on page 34](#).

Note

The radius values given in the chart are 3/4" smaller than the wall sheet radius at the bottom. This ensures that the scribed circle can be seen during assembly. A perfectly placed ring of sheets should be 3/4" on the outside of this scribed circle.

- c. Scribe the bin circumference onto the foundation.

Important

Follow these steps carefully. It is imperative that the bin be as round as possible.

Table 10. Scribe Radius and Peak Ring Height (1 and 2 tier)

Nominal Bin Dia.	Scribe Radius		Top of Peak Ring Height "H" with 1 tier of wall sheets		Top of Peak Ring Height "H" with 2 tiers of wall sheets		
	(ft)	(ft in)	(m)	(ft in)	(m)	(ft in)	(m)
15		7'4-3/4"	2.255	7'9-3/8"	2.372	11'5-3/8"	3.489
18		8'10-11/16"	2.710	8'7-3/4"	2.635	12'3-3/4"	3.753
21		10'4-9/16"	3.164	9'6-1/16"	2.897	3'2-1/16"	4.015
24		11'10-1/2"	3.619	10'4-7/16"	3.160	14'0-7/16"	4.279
27		13'4-3/8"	4.074	11'2-3/4"	3.423	14'10-3/4"	4.540
30		14'10-5/16"	4.529	11'7-5/8"	3.546	15'3-5/8"	4.664
33		16'4-3/16"	4.984	12'5-15/16"	3.808	16'1-15/16"	4.910
36		17'10-1/8"	5.438	13'4-1/4"	4.071	17'0-1/4"	5.188
39		19'4"	5.893	14'2-5/8"	4.334	17'10-5/8"	5.452
42		20'9-15/16"	6.348	15'0-15/16"	4.596	18'8-15/16"	5.714
45		22'3-13/16"	6.803	15'11-5/16"	4.859	19'7-5/16"	5.977
48		23'9-3/4"	7.258	16'9-5/8"	5.121	20'5-5/8"	6.239
51		25'3-5/8"	7.712	17'5-5/8"	5.325	21'1-5/8"	6.442
54		26'9-9/16"	8.167	18'4"	5.588	22'0"	6.706

Assemble the Top Tier of Wall Sheets

1. Assemble a single tier of wall sheets if single-tier uprights are included in the bin package.
2. Assemble two tiers if two-tier uprights are included in the bin package.
3. Refer to the Appendix for information on proper hardware usage.
4. After the first ring of wall sheets has been assembled, check the position and roundness of the ring:
 - a. Verify that the bin is round, with **no more than 0.75" variation** on the radius, when measured from the center of the bin.
 - b. Verify that the wall sheets form a smooth circle with no flat spots or cauliflower shaped curves.

Note

Correcting for roundness becomes much more difficult the longer you wait.

5. When setting jacks, make sure they are also set round and that they are anchored to the concrete.

Install the Top Ring Angle Sections

Important

Read and fully understand the following instructions before attaching the top ring angles to the top of the wall sheets. There are timing considerations for the inspection hatch, outside ladder, inside ladder, rib caps, and other components.

1. Attach the top ring angle to the inside top of the wall sheets.
 - a. Do not align the top ring angle joints with wall sheet joints.
 - b. Make sure that the top ring angle joints are at least two or three wall sheet holes away from the Grain Gauge cutout.
 - c. If building a stiffened bin, do not install the top angle bolt that lines up with the stiffener holes at this time. It needs to be installed with the stiffeners.
2. There are six pairs of vertically aligned circular and square holes in the top ring angle. (See [Figure 15 on page 35](#))
 - a. These are used to attach the center holes at the bottom of the roof sheets to the top ring angle. This locks in the correct centering location of the roof sheets, which is important for locating roof accessories such as the inspection hatch, roof ladder, rib caps, and roof stairs, etc.
 - b. Whichever pair of vertically aligned circular or square holes you choose to attach the first roof sheet center hole to, the next pair of vertically aligned circular or square holes over, to the left or right, will be used as a Bird Stop location. (See [Figure 15 on page 35](#))
 - c. The next pair of vertically aligned circular or square holes over from the Bird Stop location, will be another roof sheet center hole location.
 - d. This pattern will repeat all the way around the bin.

Note

To make timing easier of other parts, and accessories on the bin, best practice is to mark all important locations on the top angle using a marker.

3. Because the inspection hatch is in the center of the roof sheet, the inspection hatch will be centered on one set of the vertically aligned circular or square holes.
 - a. If this bin is equipped with an inside ladder, center the inspection hatch above the inside ladder.
 - b. Do not align the inside ladder with stiffeners.
 - c. Do not attach inside ladder brackets at stiffener locations or vertical seams.
4. The slots in the top ring angle align with the other non-center holes in the roof sheet.

Note

If using bin jacks through the top ring angle, jack bolts will need to be longer. Knowing jack placement before attaching the top ring angles will eliminate the need for replacing bolts.

Figure 15. Top Ring Angle Timing Details

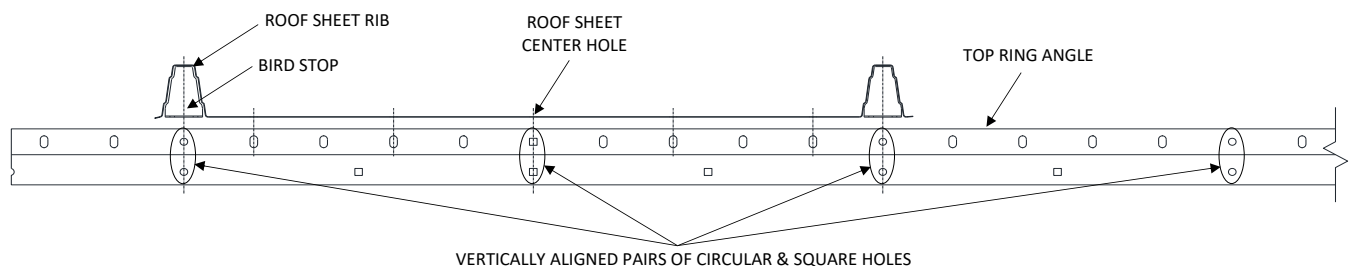

Install Bird Stops

Bird stops consist of a metal bird stop bracket, an adhesive backed foam closure and a nut and bolt.

1. Install bird stops at the bottom end of all roof panel ribs:
 - a. Best practice is to install bird stops before attaching the roof panels. (Easier access to bolts and aids with timing)
 - b. Install bird stops at locations that are five holes to the left or right of the roof panel center mounting holes in the top ring angle.
 - c. Best practice is to install the bird stop with the flange placed under the top ring angle instead of on top of it.

Figure 16. Bird Stop Installation

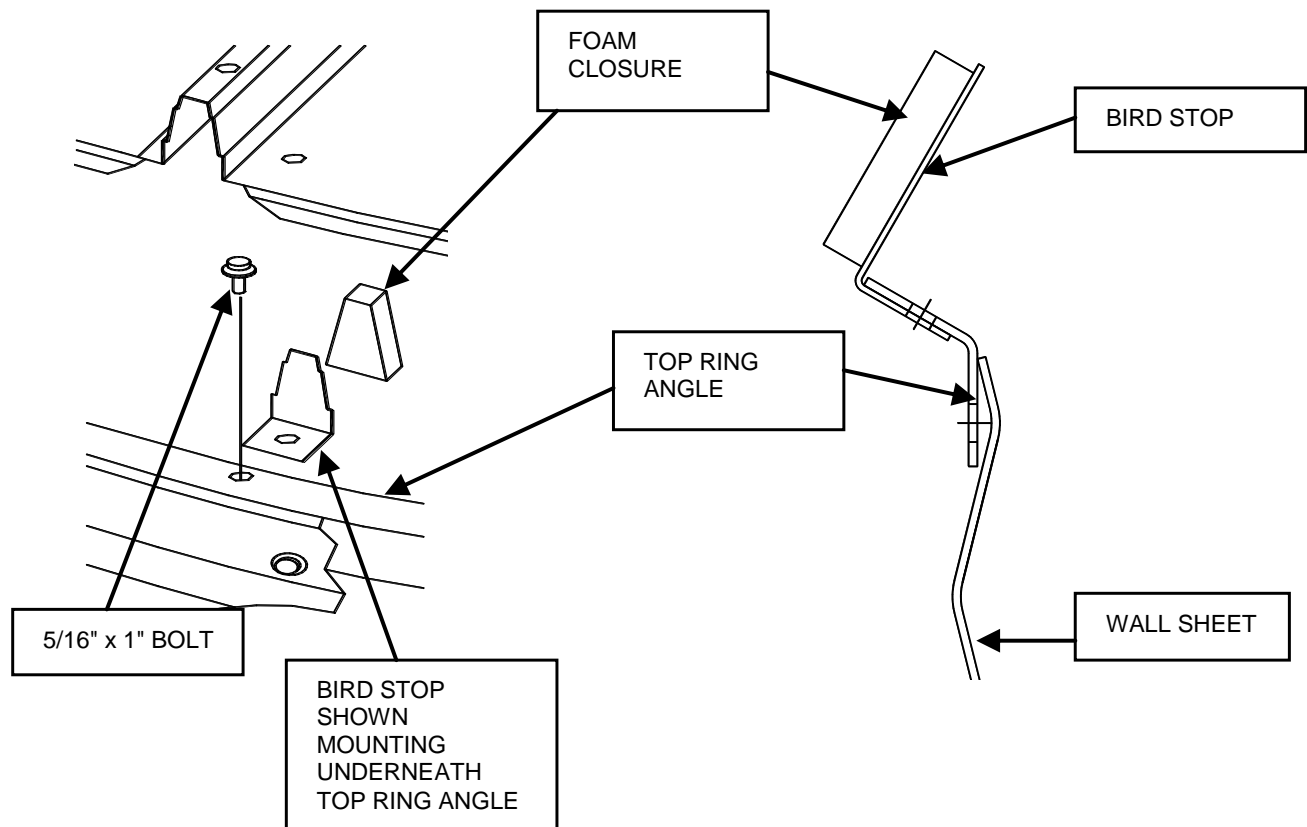

Tip

Mounting the bird stop under the top ring angle prevents it from turning when tightening the nut.

Install the Peak Ring

1. Determine the correct peak ring height (H) for the bin size from [Table 10 on page 34](#).
2. Attach the peak ring assembly to the top of the center post at the correct height for the bin being assembled.

Figure 17. Peak Ring Installation

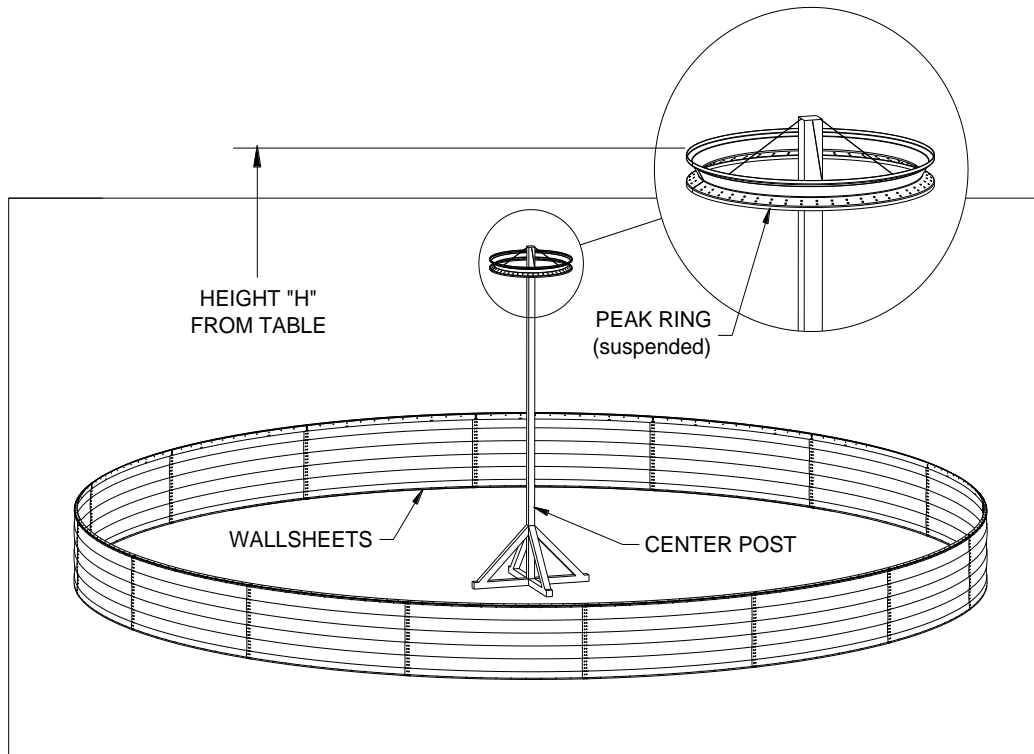

Install the Roof Sheets

1. Attach roof sheets with the narrow end to the peak ring and the wide end to the top ring angle.
2. Initially, attach four roof panels at the quarter points of the bin. (See [Figure 18 on page 37](#).)
This will stabilize and support the peak ring during the rest of the installation.

Figure 18. Roof Panel Installation

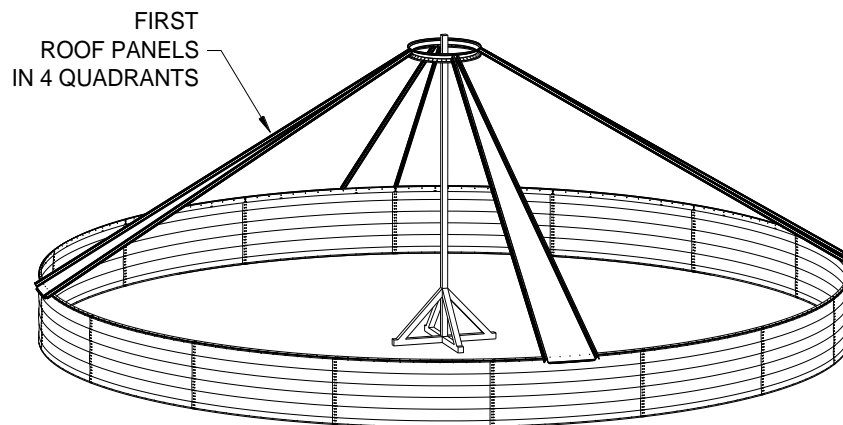

Tip

The narrow end of the roof panels gets pushed into the foam closure. Once this occurs there is little room for adjustment at the top end as the roof panel is embedded in the foam. Sometimes the roof panels get “flattened” slightly from bundling, shipping and handling. It is relatively easy to push the ribs together slightly but this should occur before the panel is seated in the foam. Monitor the alignment of mating roof panels with the underlying holes in the peak ring and make adjustments, if necessary, before anchoring the roof panel into the foam.

Important

Be careful when attaching the bottom of the roof panels to the top ring angle. The center round holes at the bottom of the roof panels must align with either the vertically-aligned round or square holes in the top ring angle. This locks in the correct centering location for the roof sheet. The other non-center holes in the bottom of the roof sheet align with the round slots in the top ring angle.

3. Make sure that the gap between the roof panel and the peak-ring is sealed by the foam closure.
4. Install the remaining roof panels, working in a counter clockwise direction:
 - a. Attach the center roof panel hole first.
 - b. Use two bolts at each roof panel to peak ring connection.
 - c. Fill in every bolt hole in roof panel ribs with rubber washered bolts to the outside and nuts on the underside.
 - d. Make sure the left roof rib overlaps the right rib of the preceding panel. (See Detail 2 in [Figure 19](#).)

Figure 19. Roof Rib Orientation & Roof Ring Bracket Assembly

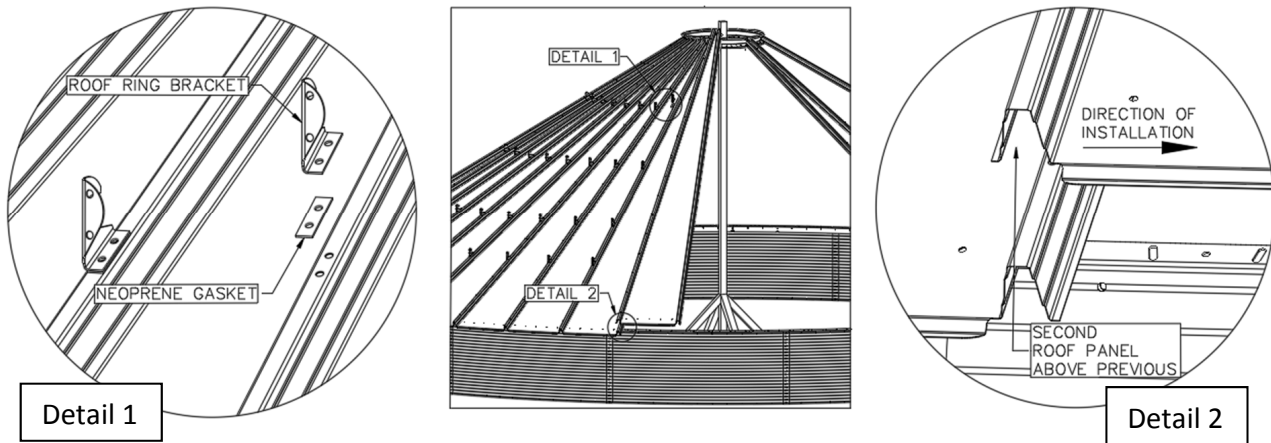
**Important**

As assembly proceeds, additional support is advised to keep the peak ring level. Alternatively sequentially add roof panels in the different quadrants such that the weight of the panels on the peak ring remains uniformly distributed. Leave all roof bolts loose until the roof is completely assembled, especially those at the peak ring and top ring angle locations.

- e. Install rib caps as needed on top of the roof ribs. (See [Install the Roof Rib Caps on page 40](#).)
 - f. If the number and diameter of optional roof stiffening rings is known, install the roof ring brackets (with a neoprene gasket under each) in the double rib hole locations as you add roof panels. (See [Detail 1 Figure 19 on page 38](#).)
5. Install vent roof panels where required, as the roof is being assembled.

Distribute vent roof panels evenly around the roof. Ensure that they do not interfere with other roof elements such as roof stairs or rungs, rib caps, temperature cables, etc.

Note

Westeel supplied roof vents come in two styles: Gooseneck and Round. Both have pre-formed bolt holes for mounting to the roof panel. The vent roof panels have a raised mount section, mounting holes and a pre-cut ventilation opening. No on-site cutting is required. A recommended practice is to assemble the vents to the roof panels at ground level before installing. Place a strip of caulking all the way around the weather side of the connection, position the vent, and bolt into place.

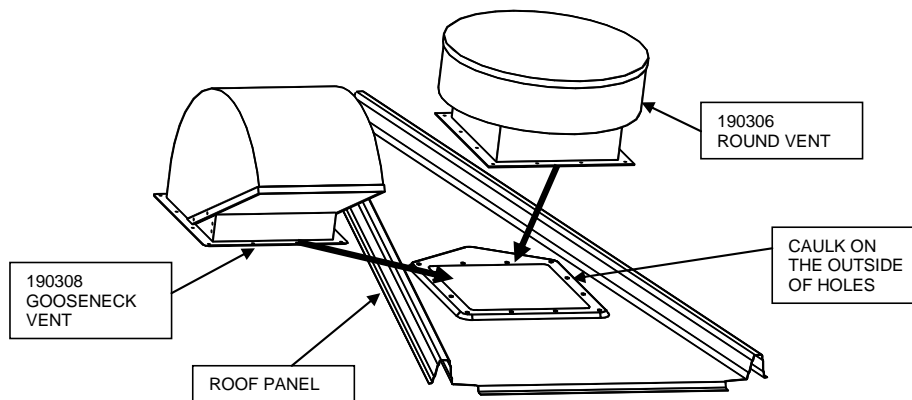
Figure 20. Roof Vent Assembly

6. Install inspection hatch roof panel where required. The inspection hatch can be pre-assembled if desired. (See [Section 5.11 – Inspection Hatch Details on page 50.](#))
7. Install the roof ladder on the roof sheet to the left of the inspection hatch. (See [Section 5.9 – Roof Ladder Details on page 48.](#))

Note

Install a set of rib caps on the roof ribs to the left of the roof ladder.

Note

Enough roof ladder rungs are supplied to bridge across every pair of holes on a single roof panel. Where roof stiffening ring brackets are placed, the ladder rung can be skipped. The roof ring will serve as a rung in this location. Roof ladder rungs are installed with the higher vertical flange facing the peak ring.

Install the Roof Rib Caps

NOTICE When assembling the Westeel bin roof, a new part has been added to the structure. They are identified as Roof Rib Caps. These new parts are considered structural and must be permanently installed on all bins sold in 2022 and after. See 7.2 Rib Cap Quantities, page 77 for rib cap part numbers and quantities needed for each bin model.

Note

It is recommended to install the SureTrack monitoring system at the same time as when the Westeel bin roof is being installed. Refer to the SureTrack monitoring system installation manual for all necessary parts and instructions.

Figure 21 shows a 24' diameter roof as an example of where to install the rib caps that are in sets of two (single roof sheets) and Figure 22 shows a 48' diameter roof as an example of where to install the rib caps that are in sets of four (groups of three roof sheets together).

Note

Roof sheets are numbered starting at the roof ladder sheet (roof sheet 1), in a counter-clockwise direction.

Figure 21. 2404 Rib Caps Example

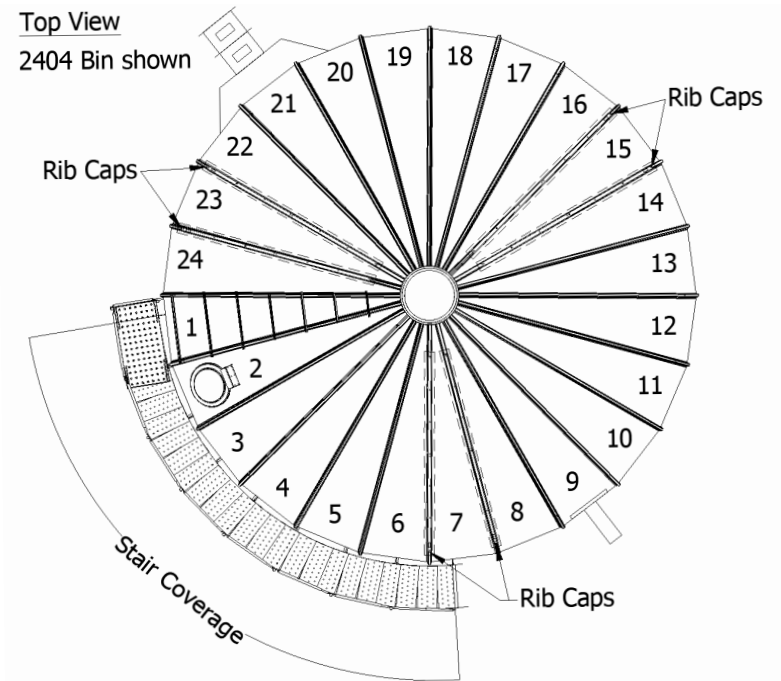
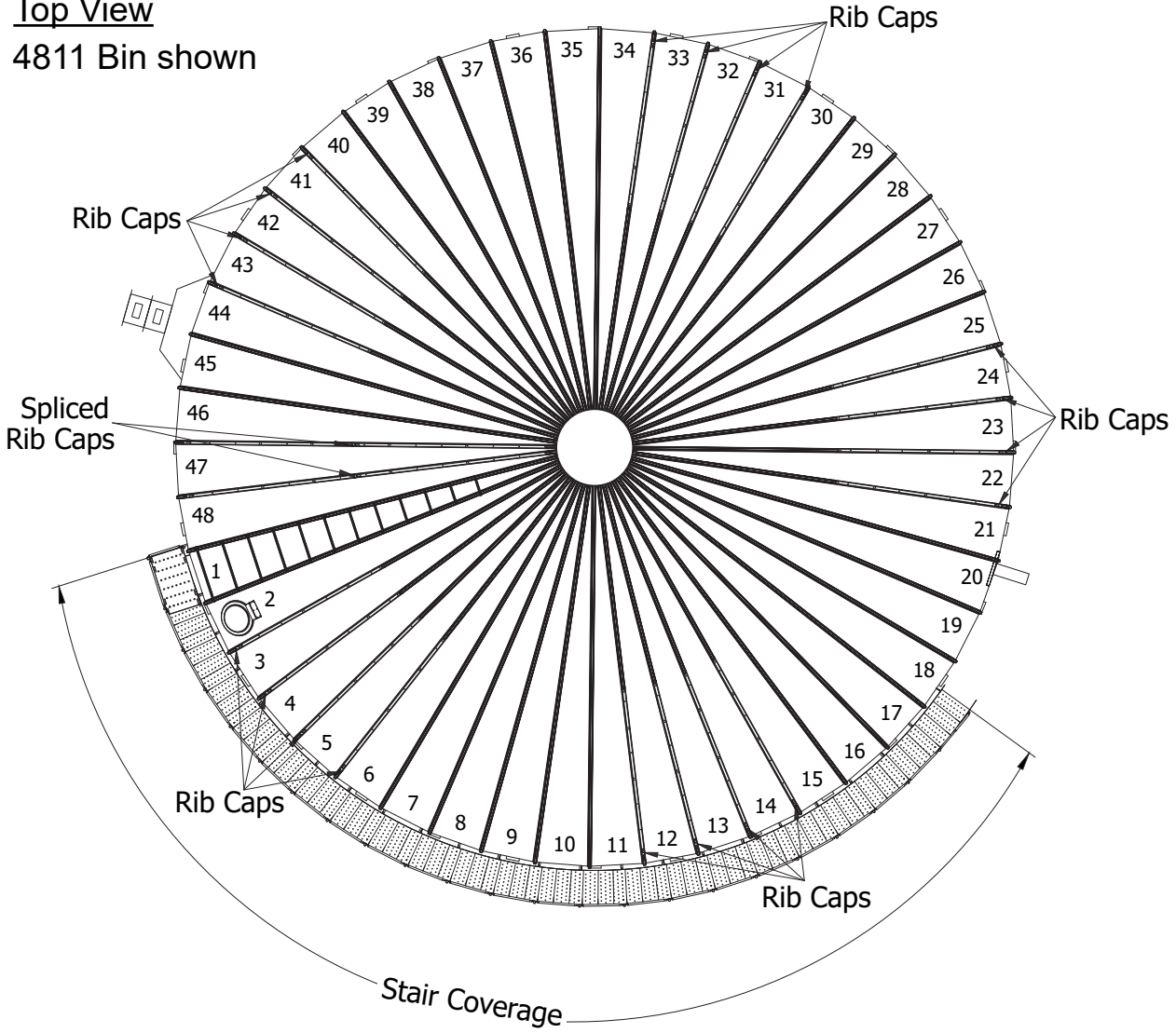

Figure 22. 4811 Rib Caps Example

Top View

4811 Bin shown



Note

If the inspection hatch is installed at a different location, additional timing considerations will be needed for the rib caps.

Note

Timing considerations are needed for the RCO's slide rod to avoid any roof sheets numbered in [Table 11](#). If a fan is equipped, consider lining up the RCO's slide rod and winch beside the fan.

Install the Roof Rib Caps (15'–36' Bins)

Table 11 shows rib cap locations in sets of two (single roof sheets), and sets of four (groups of three roof sheets together).

Table 11. Roof Sheet Locations for Rib Caps

Bin Diameter (ft)	Bin Models	Roof Sheet Locations	
		Peak Cable Roof Sheet	Perimeter Cable Roof Sheets
15	Up to 13 Tiers	14	—
18	Up to 13 Tiers	17	—
21	Up to 13 Tiers	20	—
24	Up to 14 Tiers	—	7, 15, 23
27	Up to 14 Tiers	—	8, 17, 26
30	Up to 9 Tiers	—	9, 19, 29
30	10 to 14 Tiers	—	7-8-9, 17-18-19, 27-28-29
33	Up to 12 Tiers	—	10, 21, 32
33	13 to 14 Tiers	—	8-9-10, 19-20-21, 30-31-32
36	Up to 12 Tiers	35	5, 17, 29
36	13 to 14 Tiers	35	4-5-6, 16-17-18, 28-29-30

Note: The roof sheet locations are numbered starting with the ladder roof sheet, in a counter-clockwise direction.

For 15' to 36' bins, Follow the instructions below:

1. The rib cap's label is located at the eave end to help orient the roof rib cap prior to sliding it up on the roof. This will ensure the bolt hole pattern on the rib cap will match the roof rib.
2. As each roof panel is installed, if a rib cap is required, slide the rib cap on top of the roof rib until the rib cap's bottom hole towards the eave is in line with the roof rib's bottom hole towards the eave. Then bolt the roof rib cap onto the roof ribs.

Figure 23. One-Piece Rib Cap

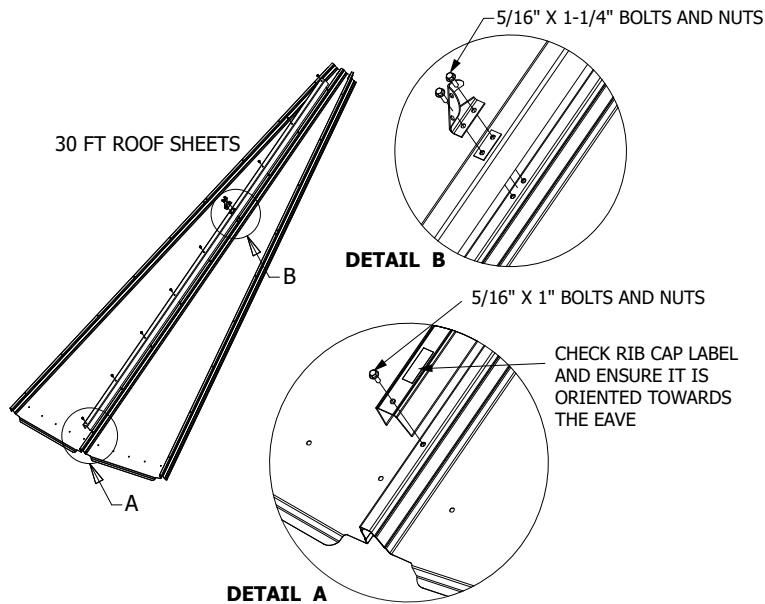

Install Roof Stiffening Rings

1. Add roof stiffening rings (if required):
 - a. See [Table 12 on page 46](#) for standard roof stiffening ring locations.
 - b. On roofs with multiple stiffening rings, stagger the ring joints to avoid having more than one joint on same roof sheet. (See [Figure 24 on page 43.](#))

Figure 24. Roof Stiffening Rings Installation

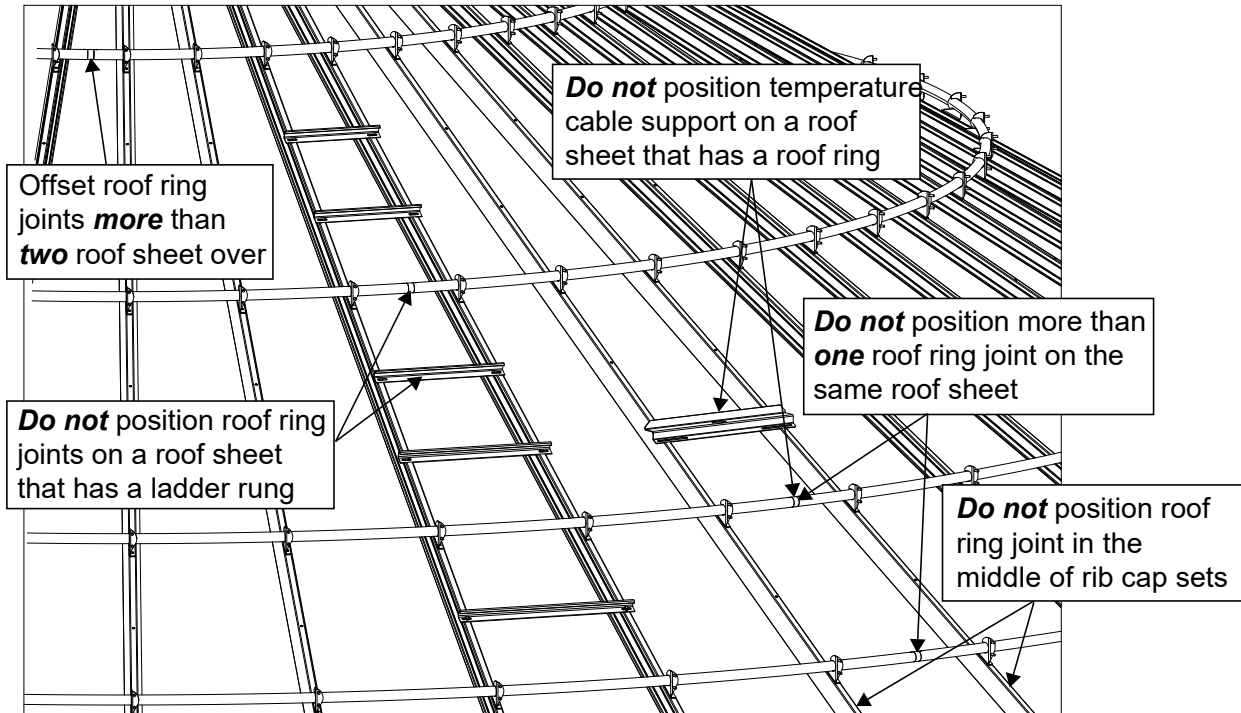

- c. Join roof stiffening rings together by inserting a ring splice into the facing ends and pushing everything together tightly.
- d. Secure the splice to the roof ring with a self-drilling screw.

Figure 25. Stiffening Ring Connection

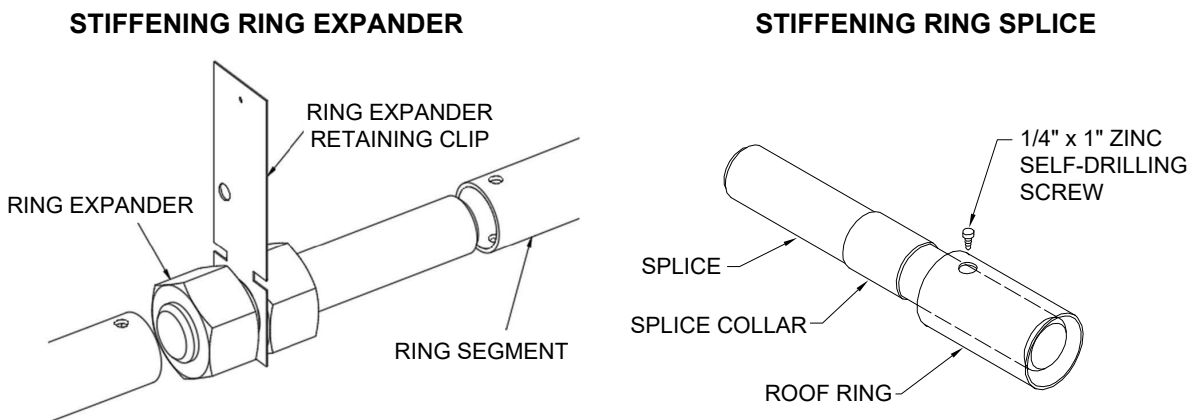

- e. Field cut the last stiffening ring segment so there is a 2½" gap between the mating tubes.

- f. To make the final connection, insert a ring expander between the final ring sections.
- g. Remove one nut from the ring expander, slide the ring expander retaining clip onto the threaded portion against other nut. Thread removed nut back on. (See [Figure 25 on page 43](#)).
- h. With nuts close to one end, insert the long end of the ring expander into one tube and, by flexing both tubes, make the connection to the mating tube. (See [Figure 25 on page 43](#).)
- i. Thread both nuts toward the center.
The green paint on the threaded portion indicates the center.
- j. Slide stiffening ring tubes into the brackets.

Note

Before expanding, or tightening the roof, all nuts on the ring expanders should be tight together and centered.

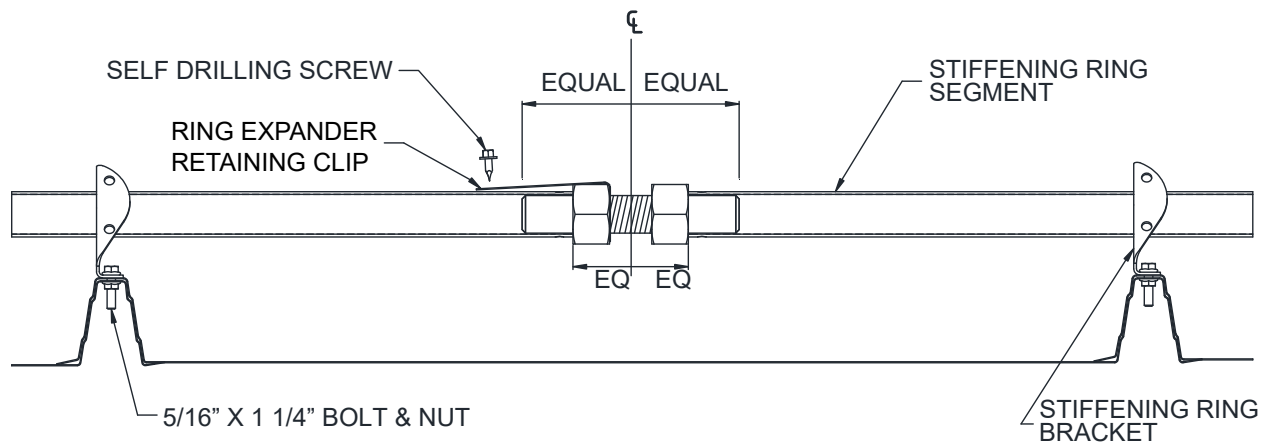
Figure 26. Stiffening Ring Connection (side view)

2. Tighten the roof hardware.
3. Expand the nuts on the stiffening ring expanders until the slack has been taken up and the roof is snug.
 - a. Do not overtighten and crown the roof.
 - b. Nuts must be centered on the threaded rod.
 - c. Use the painted marking as a guide.
 - d. On rings with multiple expanders, the distance between the nuts on all of them should be equal. (See [Figure 26 on page 44](#).)
4. Slide retaining clip against one nut, bend clip over nut and flat against stiffening ring. Secure the retaining clip to the stiffening ring with a self drilling screw. (See [Figure 26 on page 44](#).)
5. Install u-bolts into stiffening ring brackets, tighten the u-bolts until stiffening ring is pulled tight against the brackets. (See [Figure 27 on page 45](#).)

Figure 27. Stiffening Ring Bracket Assembly

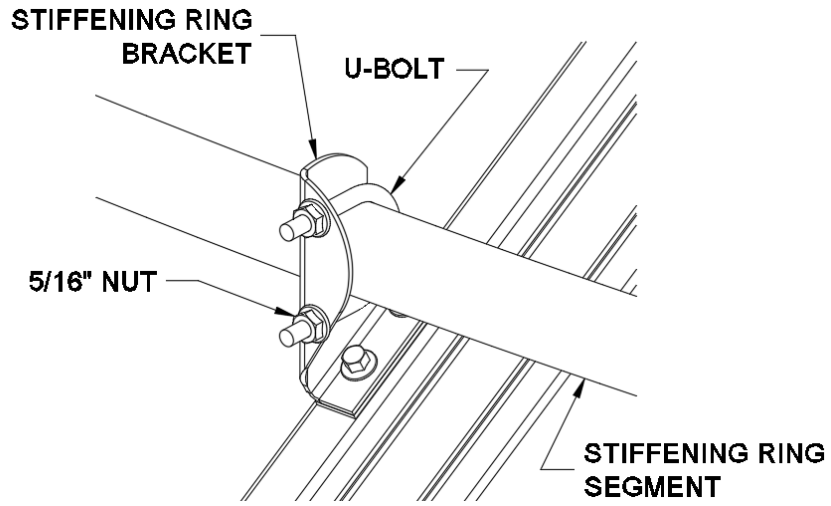

6. Once all the roof panels have been installed, make sure all nuts have been tightened.

Table 12. Roof Reinforcing Matrix

Component →	Roof Stiffening Ring Tubes				Rib Supports			
Location & Colour →	1st - Yellow	2nd - Black	3rd - Red	4th - Green	Under ribs			
Chord length (in) →	103.8	167.4	197.6	200.4	Varies			
Qty of Expanders →	2	2	3	4	n/a			
Bin Series	Component Part Numbers (and Quantity)							
15	n/a	n/a	n/a	n/a	n/a			
16					n/a			
18					n/a			
21					212752 (21)			
24					212753 (24)			
27	195100 (5)	n/a	n/a	n/a	n/a			
30	195100 (5)				212755 (30)			
33	195100 (5)				195101 (5)	212756 (33)		
36	195100 (5)				195101 (5)	212757 (36)		
39	195100 (5)				195101 (5)	195102 (6)	212758 (39)	
42	195100 (5)				195101 (5)	195102 (6)	212759 (42)	
45	195100 (5)				195101 (5)	195102 (6)	212760 (45)	
48	195100 (5)				195101 (5)	195102 (6)	195103 (7)	212761 (48)
51	n/a				195101 (5)	195102 (6)	195103 (7)	212762 (51)
54					195101 (5)	195102 (6)	195103 (7)	212763 (54)
Notes:	<ul style="list-style-type: none"> Roofs are supplied as standard or with optional upgrades for higher load capacity 							
	<- standard components for all roofs							
	<- optional components supplied with all roof upgrade levels 1 & 2							
	<- optional components supplied with roofs upgraded to level 2							
	<ul style="list-style-type: none"> Structural roofs with rafter system is available for 48' bins and larger. These raftered roofs do not require stiffening rings or rib supports 							

Install Roof Rib Supports

Rib supports are an upgrade that provide additional load capacity when required. Rib supports vary in length, depending on roof size and are designed to fit under the roof panel ribs. They run along the length of the rib from the eave (at the bottom) to near the peak ring (at the top).

1. Install one rib support at each roof rib location:
 - a. Fit the rib support onto the shanks of the existing bolts used to join mating roof ribs.
 - b. Add a second nut to secure the rib supports to the ribs. (See Rib Support Connection Detail in [Figure 28 on page 47.](#))

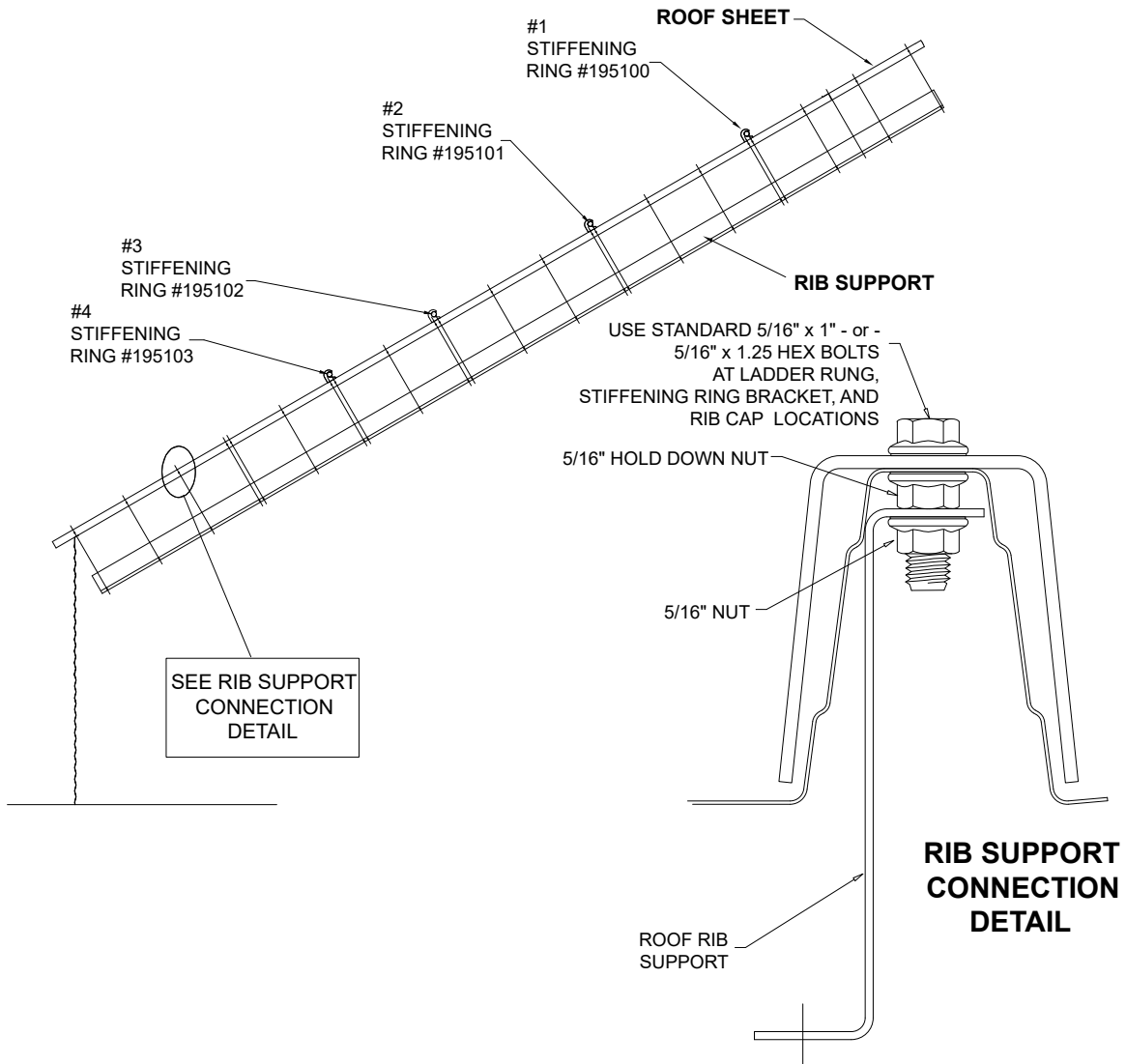
Figure 28. Roof Rib Support Assembly

(Drawing represents a non-specific example only)

Install Associated Components

1. Assemble bin entry anchor system, roof cap, roof cap opener, ladders and associated components (if applicable).
 - See [Section 5.10 – Flat Roof Cap Assembly on page 49](#)
 - See [Section 5.9 – Roof Ladder Details on page 48](#)
 - See [Section 5.13 – Bin Entry Anchor System: Non-Structured Roof on page 52](#)

5.9. Roof Ladder Details

1. Locate the roof panel containing the roof ladder components to the left or right of the inspection hatch, and in line with the outside ladder.
2. Recommended (for convenience): Attach the roof ladder and a section of the outside ladder early, when the roof section is at ground level.
3. Start at the bottom of the roof with the longest ladder rung supplied and move up the roof using progressively shorter ladder rungs.
4. Bolt ladder rungs to the roof panel ribs using the pre-drilled holes in the ribs.
5. Use 5/16" x 1-1/4" hex bolts and hex nuts (bolts above and nuts underneath).

Note

Make sure that a STL/NEO sealing washer is installed between the ladder rung and the roof sheet.

Note

The ladder rung is oriented with the vertical portion facing up towards the peak ring. When a ladder rung is located at a double hole pattern designed for a roof-ring element, bolt through the upper holes and fill the other holes with a 1" hex bolt. No ladder rung is used at a roof-ring location. The ring itself will serve as a step. This ladder rung can be discarded or saved for another job.

Figure 29. Roof Ladder Details

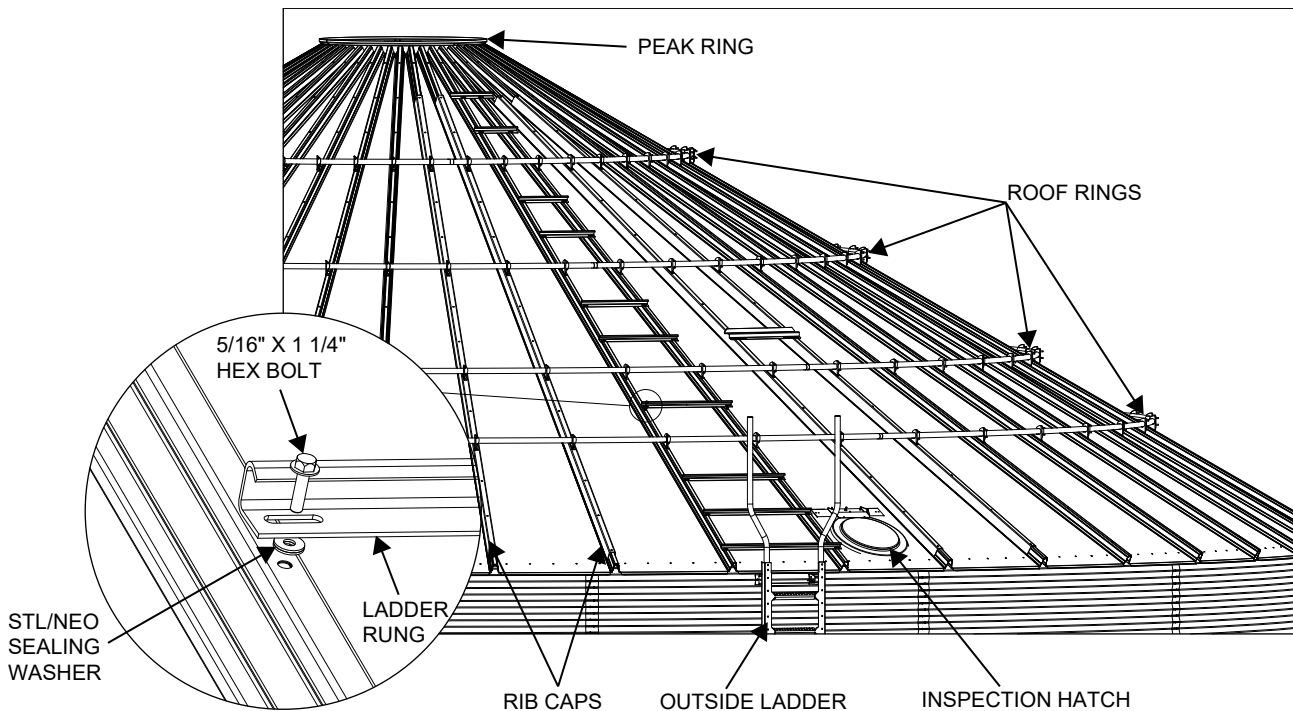

5.10. Flat Roof Cap Assembly

Figure 30. Flat Roof Cap Assembly Detail

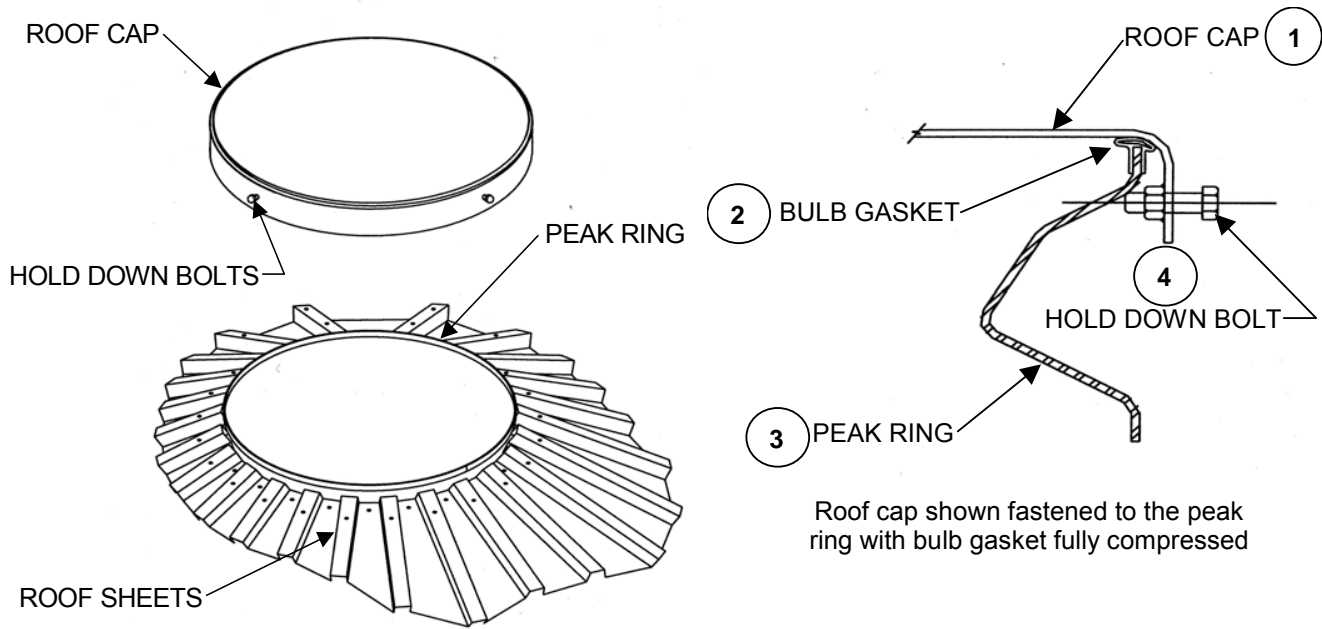

Table 13. Flat Roof Cap Part Numbers

Item	Description	Part No.	Used On
1	34" HEAVY DUTY FLAT CAP (for use with 33" peak ring)	195090	up to 27' Bin
	53.5" HEAVY DUTY FLAT CAP (for use with 52" peak ring)	195087	30' to 48' Bin
	61.5" HEAVY DUTY FLAT CAP (for use with 60" peak ring)	195091	51' & 54' Bin
2	PEAK RING BULB GASKET 105" LONG	195149	up to 27' Bin
	PEAK RING BULB GASKET 168" LONG	195150	30' to 48' Bin
	PEAK RING BULB GASKET 105" LONG	2 x 195149	51' & 54' Bin
3	3/8" x 1-1/2" HEX FLANGE BOLT (supplied with the lid)	193797	All

1. Fasten the bulb gasket onto the top rim of the peak ring. Trim to fit.
2. Place the roof cap on the peak ring with two of the hold down bolts, making sure they are clear of the roof ladder.
3. Locate bolts between the roof ribs.
4. Tighten the hold-down bolt opposite the roof ladder until approximately 3/8" of the bolt is protruding past the welded nut.
5. Tighten the two bolts near the roof ladder until the roof cap pulls down firmly and cannot be moved.
6. Tighten all other roof cap bolts similarly.
7. Ensure that the roof cap is fully secured around the peak ring.
8. For a non-structural roof that is supporting a catwalk, install six flat cap clips (213437) as shown in the Westeel catwalk manual 213440. These clips are provided in the Westeel catwalk peak support modules.

5.11. Inspection Hatch Details

Installation of inspection hatch

1. Place the inspection hatch gasket (235882) around the lip of the inspection hatch opening. Trim the gasket to fit if necessary.
2. Bolt on the hatch lid assembly (235890) with 5/16" x 1" bolts provided for the roof. For best sealing results, the bolt heads should be on the underside of the roof panel, with the sealing washers pressed against the roof panel.
3. Bolt on the latch assembly (235891) as shown below. The latch is positioned on the center hole of the roof panel and bolts through the top ring angle as shown.

Figure 31. Inspection Hatch Details

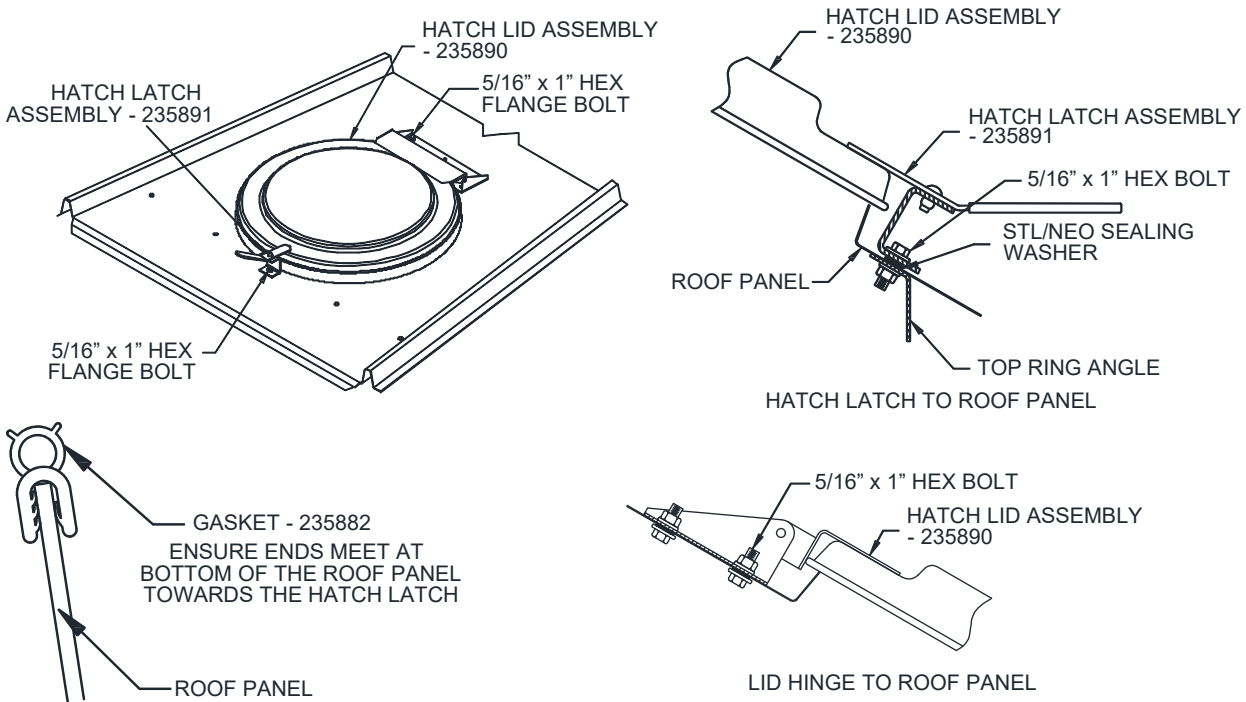

5.12. Inspection Hatch Reinforcing Plate

1. For high wind applications, place the inspection hatch reinforcing plate under the roof sheet and secure with 5/16" x 1" hex flange bolts and nuts.
2. The flange on the plate must be located away from the hatch opening to minimize the possibility of interference or injury with inspector.
3. The four outermost mounting holes are used for extra stiffening when the roof sheet width permits. Field drill the roof sheet as needed.

Figure 32. Inspection Hatch Reinforcing Plate Detail

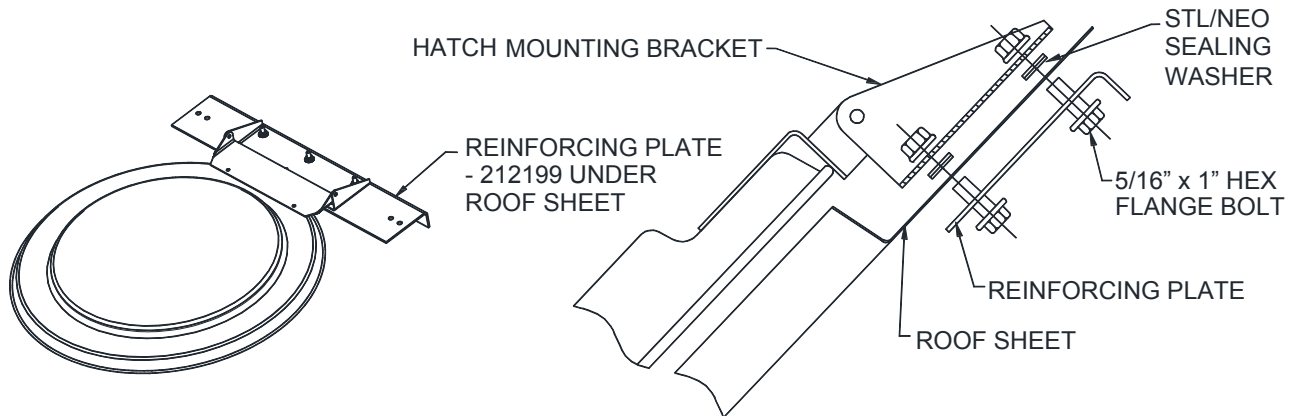

5.13. Bin Entry Anchor System: Non-Structured Roof

Important

The fall restraint bracket is rated for a maximum load of 2,000 lbs. The bin owner and user are responsible for correctly installing, using, and operating the Bin Entry Anchor System. The rope, pulley, and harness are not supplied by Westeel.

WARNING Failure to install correctly as instructed below may result in serious injury or death.

1. Install fall restraint bracket under peak ring as shown. Make sure to bolt the fall restraint bracket to the roof sheet with the inspection hatch cut out. (See [Figure 33 on page 52.](#))

Figure 33. Installing the fall restraint bracket

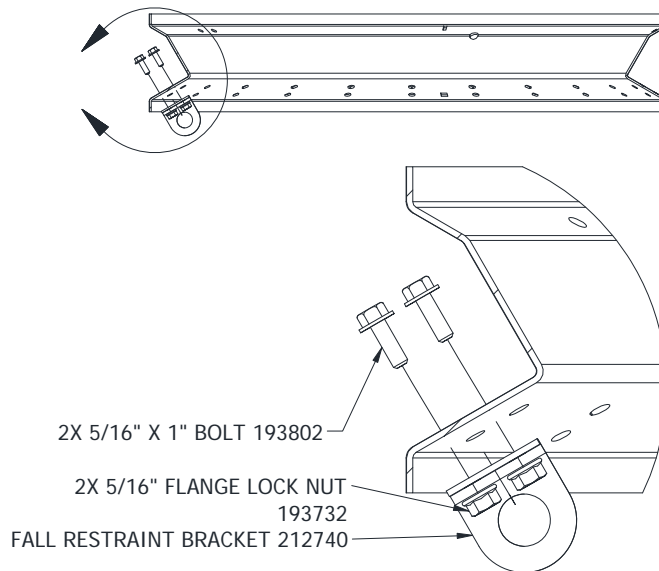

2. Bolt the second fall restraint bracket to the upright splice. Then bolt the upright splice along the top wall sheet horizontal seam with the wind ring clips, sandwiching the load spreader tube and rubber pads as shown. (See [Figure 34 on page 53.](#))
 - a. Field drill holes as needed on the wall sheet and top angle for the wind ring clip connections. Washers must be sandwiched between the wind ring clips and the wall sheet for sealing. (See [Figure 34 on page 53.](#))
 - b. The load spreader tube and upright splice can be installed off center on the wallsheet (between the uprights on stiffened bins), for better reachability from the inspection hatch. Do not install the load spreader tube over a vertical wall sheet seam. (See [Figure 34 on page 53.](#))

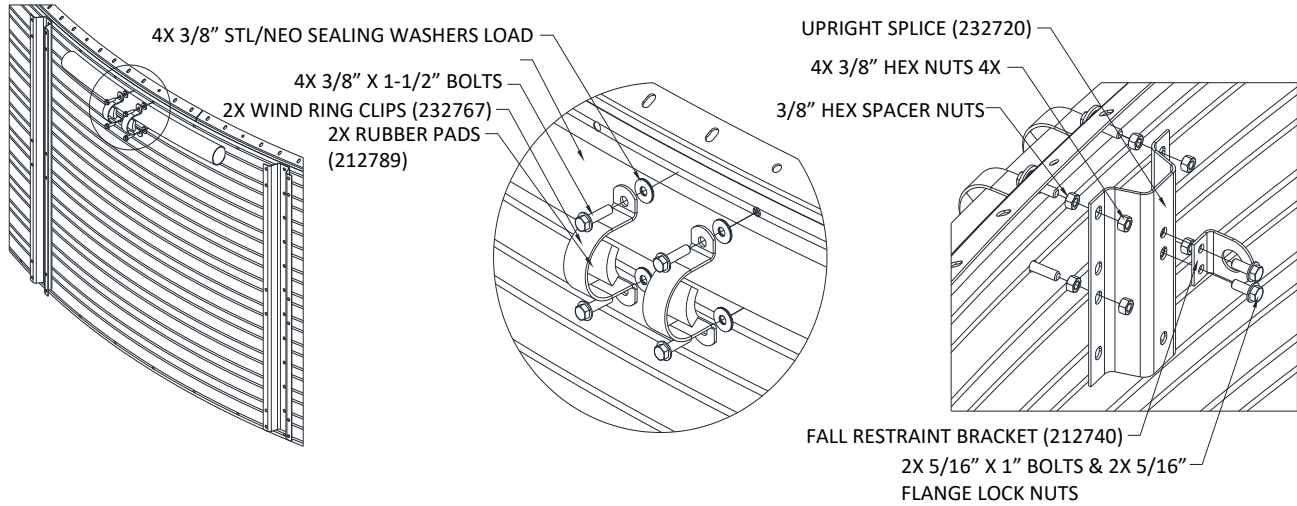
Figure 34. Installing the load spreader tube

- Place the Fall Restraint Anchor Point Decals (PN 8110-01090) on the bin, see [Section 2.5 – Decal Installation/Replacement on page 7](#) and [Section 2.6 – Safety Decal Locations and Details on page 8](#) for installation instructions and placement.

5.14. Wall Sheets

Note

Proper bolt tightening sequence must be followed at all times.

1. Loosely assemble the top tier overlapping sheets.
2. Be sure to wipe all areas of the sidewall sheets to remove excess oil in order to ensure that the caulking will adhere properly.
3. Always install the caulking strip on the weather side of every vertical seam to avoid moisture penetration. (See [Section 5.19 – Wall Sheet Caulking Detail on page 59.](#))
4. Bolt all horizontal and vertical seams using 3/8" bolts.

Note

The bolt heads go on the outside of the bin on the roof and sidewall sheets, but on the inside of the bin for stiffeners and at outside sidewall ladder connections.

5. DO NOT tighten any bolts until the roof is completely assembled and the peak ring is level.
6. Lift the bin and assemble the second tier, overlapping the sheets.
7. The horizontal bolts between the first and second tier may now be tightened. Start from the center of a sheet and work towards a vertical seam.
8. After these bolts are tightened, the vertical seams on the first tier may now be tightened, working from the center outwards.
9. Assemble the third tier:
 - a. Tighten the horizontal bolts between the second and third tier.
 - b. Work from the center of a sheet toward the vertical seams.
10. The vertical seam bolts on the second tier may now be tightened working from the center of the sheet outward.
11. Install stiffeners and sidewall ladders as you proceed with the assembly of the bin

The bolting sequence mentioned above is extremely important. Failure to tighten the bolts in this manner may cause a bubbling effect on the horizontal seams. These areas, if severe enough, may cause grain leakage.

5.15. Centurion Wall Sheet Part Number Matrix

Table 14. Wall Sheet Part Number Table

Corrugated Wall Sheets					Punched Wall Sheets			
Thickness nom (min)	Gauge	Label Colour	Weight lbs	Length (overall)	Flat	Regular	Bottom	
.040 (.036)	20	Yellow	58.3	116.5"	194654	194660 Stencil		
					194657	194663 Stencil		
					194679	194730		
.050 (.045)	18	Orange	72.8		194655	194661 Stencil		
					194658	194664 Stencil		
					194680	194731	194771	
.057 (.052)	17	Red	83.0		194681	194732	194772	
.066 (.061)	15	Pink	97.7		194682	194733	194773	
.076 (.070)	14	Lime	112.2		117.0"	194656	194662	
						194659	194665	
				194683		194734	194774	
.096 (.088)	13	Green	141.1	194684		194735	194775	
.116 (.107)	12	Blue	171.4	194685		194736	194776	
.126 (.117)	11	Purple	189.0	194606		194737	194777	
.139 (.130)	10	Black	209.4	194607		194738	194778	
Short Sheets Installed Beside the Door								
.057 (.052)	17	Red	66.3	93.0"			194780	
			26.2	36.8"				194783
.076 (.070)	14	Lime	89.6	93.0"		194781		
.096 (.088)	13	Green	44.6	36.8"			194784	
.116 (.107)	12	Blue	136.8	93.0"		194782		
			54.1	36.8"			194785	

Bottom wall sheets are punched for full floor aeration flashing. Use bin bolts provided to plug unused holes if a full floor aeration system is not being used.

5.16. One-Tier Light Duty Door (15' – 27') Installation

Figure 35. One-Tier Light Duty Door (15' – 27') Detail

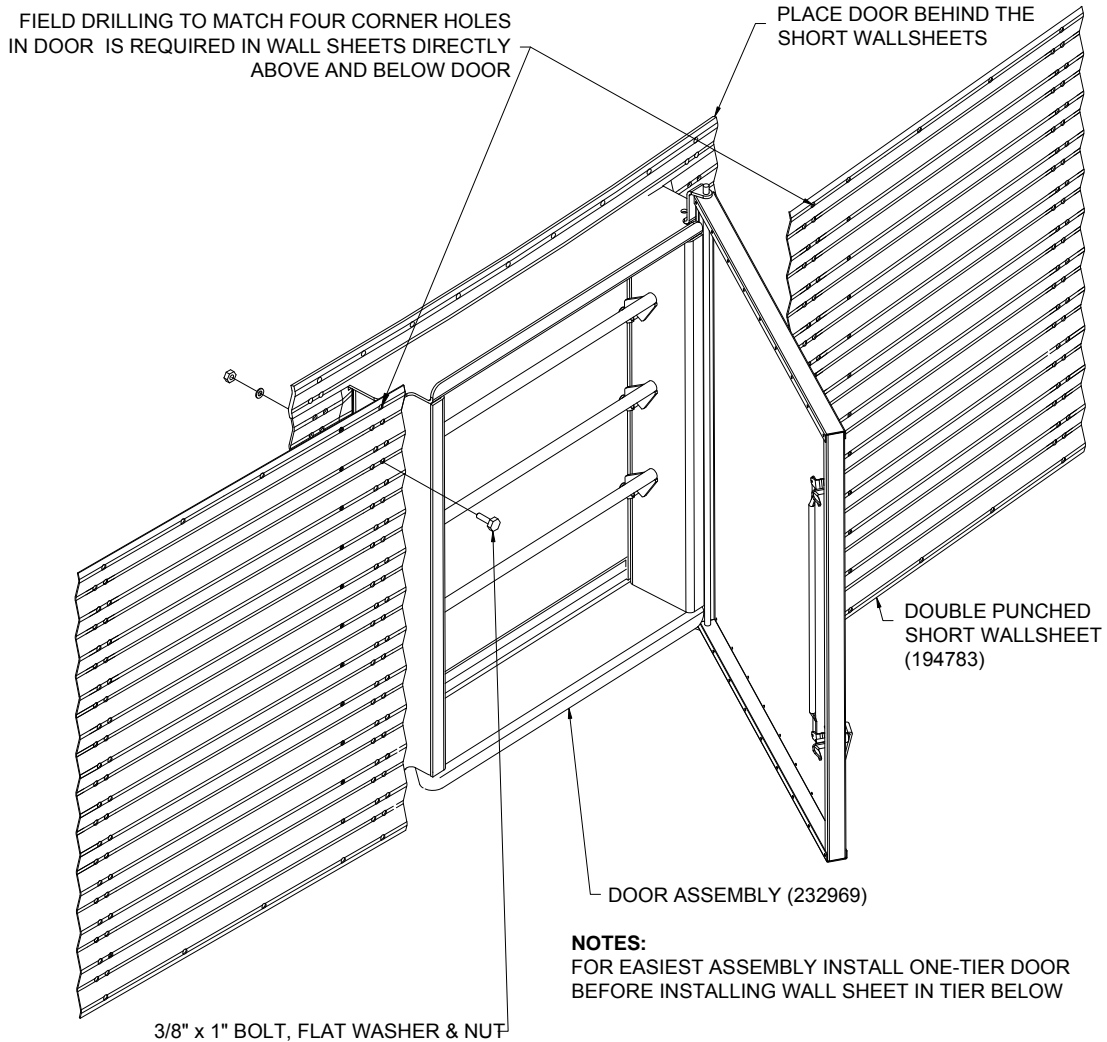

Important

The inner door board must be closed and latches completely engaged before filling. Failure and collapse of the bin could result if the bin is filled without properly closing the inner door board.

5.17. One-Tier Light Duty Door Installation

Figure 36. One-Tier Light Duty Door Detail

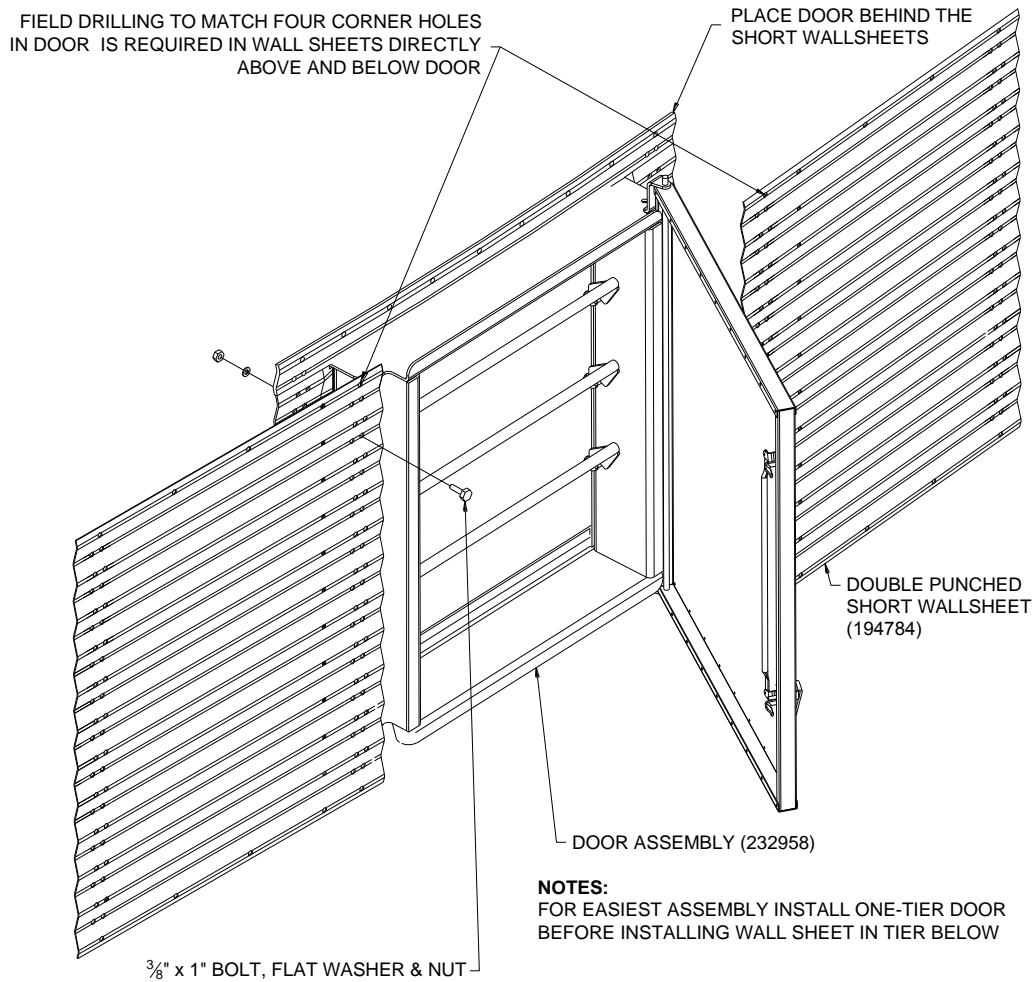

Important

Inner door board must be closed and latches completely engaged before filling. Failure and collapse of the bin could result if bin is filled without properly closing inner door board.

5.18. One-Tier Medium Duty Door Installation

Figure 37. One-Tier Medium Duty Door Detail

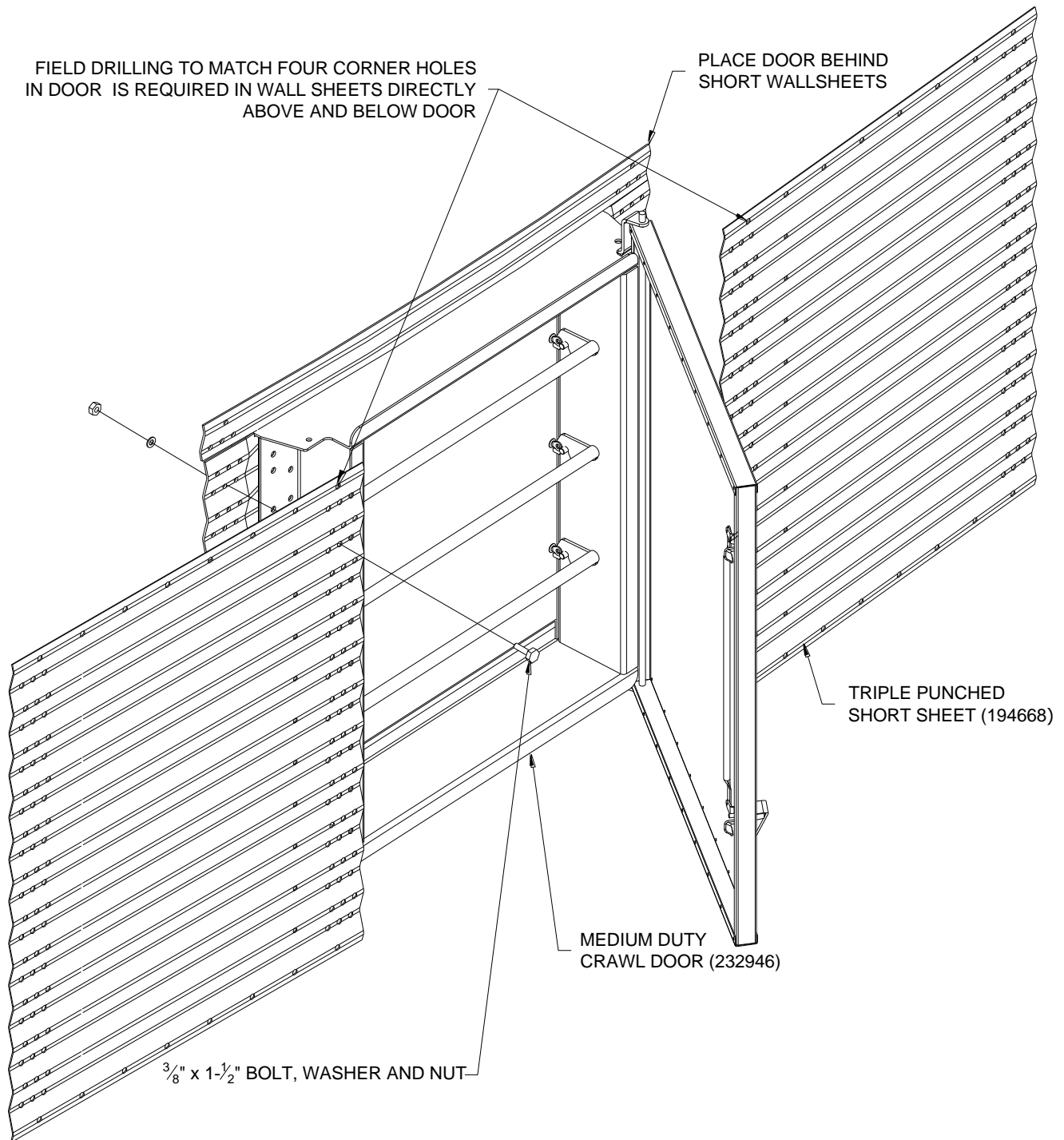

Important

The inner door board must be closed and latches completely engaged before filling. Failure and collapse of the bin could result if the bin is filled without properly closing the inner door board.

5.19. Wall Sheet Caulking Detail

Figure 38. Wall Sheet Caulking Detail (inside view) — Imperial

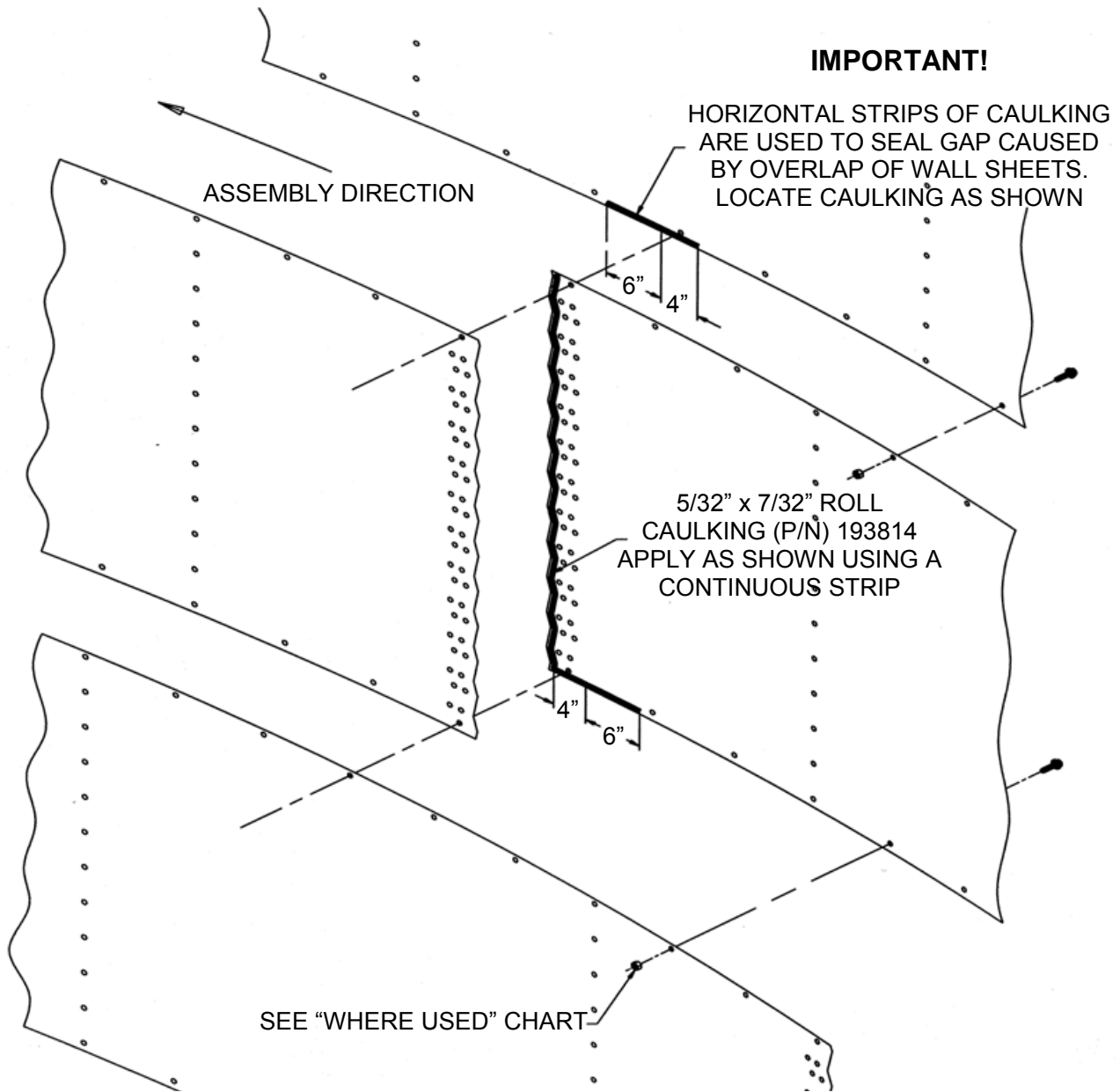
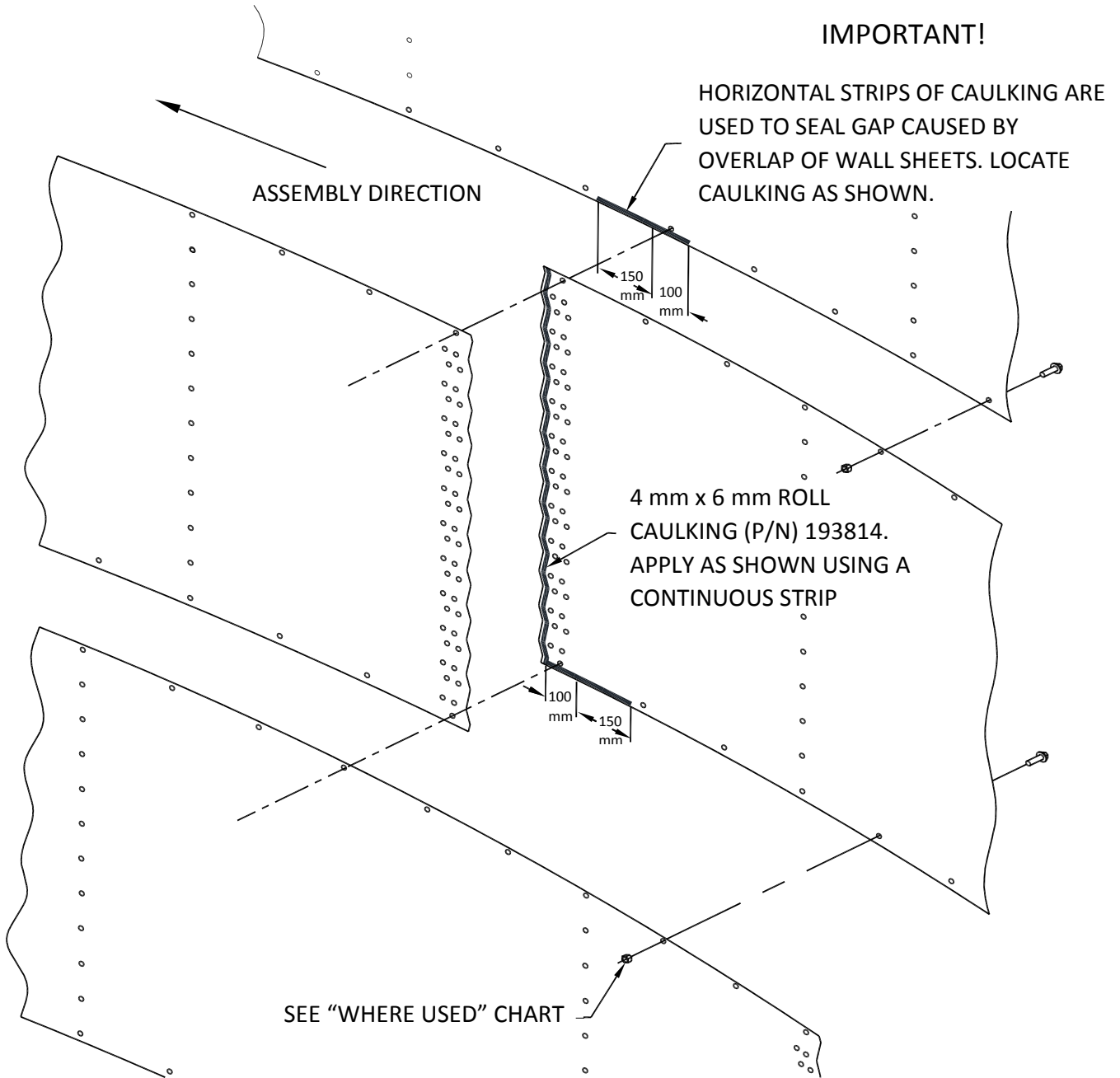

Figure 39. Wall Sheet Caulking Detail (inside view) — Metric



5.20. Commercial Bin Upright Assembly

This section provides information needed to assemble uprights for commercial bins.

Introduction

The Westeel Commercial upright system consists of uprights and laminates. Single uprights, joined by splice plates, are used at the top of bins. Laminate sections are introduced when vertical load requirements dictate. Once introduced the laminates continue to be utilized for the balance of the assembly.

A unique feature of the Westeel upright system is the progressive section. Not only do the uprights and laminates increase in gauge from the top to the bottom of the bin, they also increase in section.

Figure 40. Progressive Sections

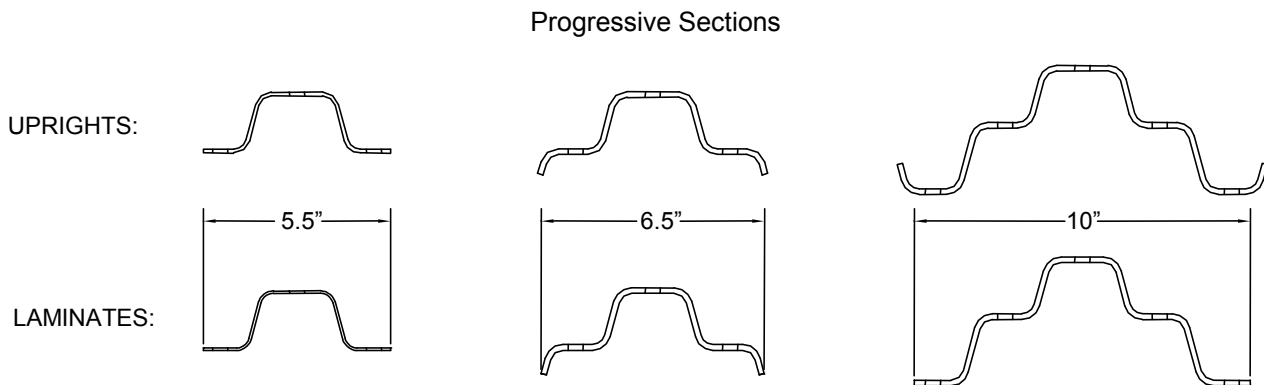

NOT ALL SECTIONS ARE USED ON ALL BINS

Both upright and laminate sections measure 88" long. In the center of each there are vertical holes spaced at 4" centers. This permits use on externally stiffened bins. There are two locations on each wall sheet for attachment of the uprights. The wall sheet holes that mate with the uprights are spaced at 4" centers. All center upright holes must be filled with bolts.

Upright/Laminate Identification

In order to properly erect the bin it is necessary to distinguish uprights from laminates, it is necessary to determine the gauge of the part, and it is necessary to determine the width of the section. The various combinations are provided in the upright/ laminate table. It is also necessary to determine the orientation of the parts as there is a distinct top and bottom. All the information that is required for assembly is contained on the label.

The label, is the easiest means of identification. It contains all of the necessary information. For assembly purposes, the label is placed on the bottom of both uprights and laminates.

Upright labels have solid colours and laminate labels are striped. For both uprights and laminates, the colour corresponds with gauge and style.

Each upright and laminate has a unique identifying letter. This is prominently displayed on the label, and corresponds with the respective assembly charts provided (see [Figure 41](#)).

Tip

For error free installation, make sure that the identifying letter on the label coincides with the wall sheet/upright layout for the bin being assembled, and that the labels on both uprights and laminates remain on the bottom. There is a definite top and bottom orientation for uprights and laminates. It is imperative that they are oriented correctly.

Figure 41. Upright and Laminate Labels

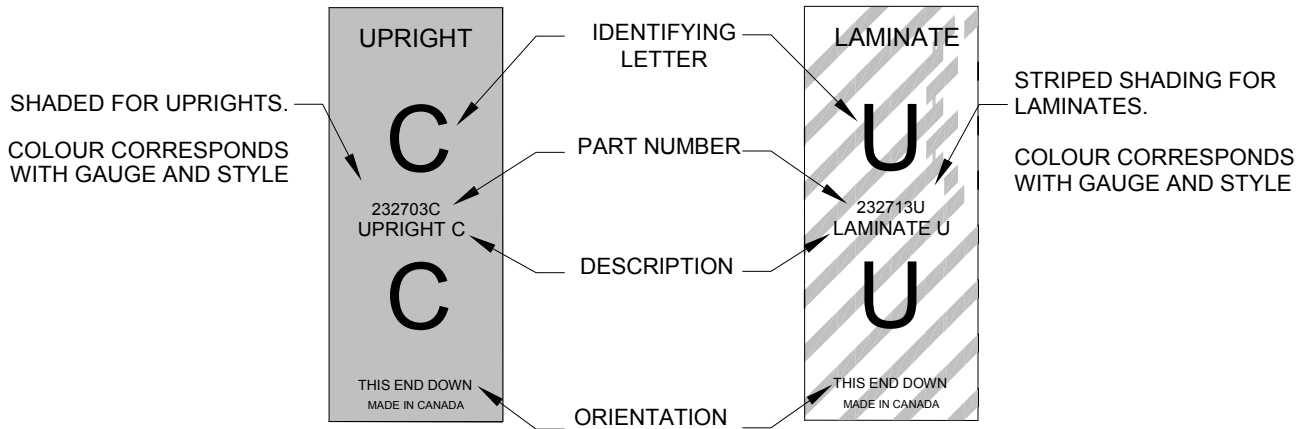

Short Upright

There is one short upright measuring 44" long for use in odd tier bins. The alpha character for this part is “S”. There is no corresponding laminate as it is used at the top of the bin before the laminates are introduced. The short upright always goes in the top tier.

Tip

The short “S” upright is located in the top tier of odd-tiered bins.

Upright/Laminate Assembly

Use the wall sheet/upright layout provided for the bin in question, to determine the proper order of the various upright and laminate components. The identifying letter on the label is the easiest means of identification. In addition to the identifying letter, every upright and laminate is also identified by gauge and width. If for some reason the label is missing from a part, the following table contains information that will aid in the identification of the various parts.

Tip

In all cases laminates nest inside uprights. The uprights are placed against the bin wall sheets and the laminates are away from the wall sheets.

It is important to get the first uprights started correctly. The top hole in the top upright bolts into the top horizontal wall sheet seam (see Figure 42).

Tip

For proper upright orientation align the bottom of the first upright with the bottom edge of a wall sheet.

Figure 42. Upright Orientation Detail

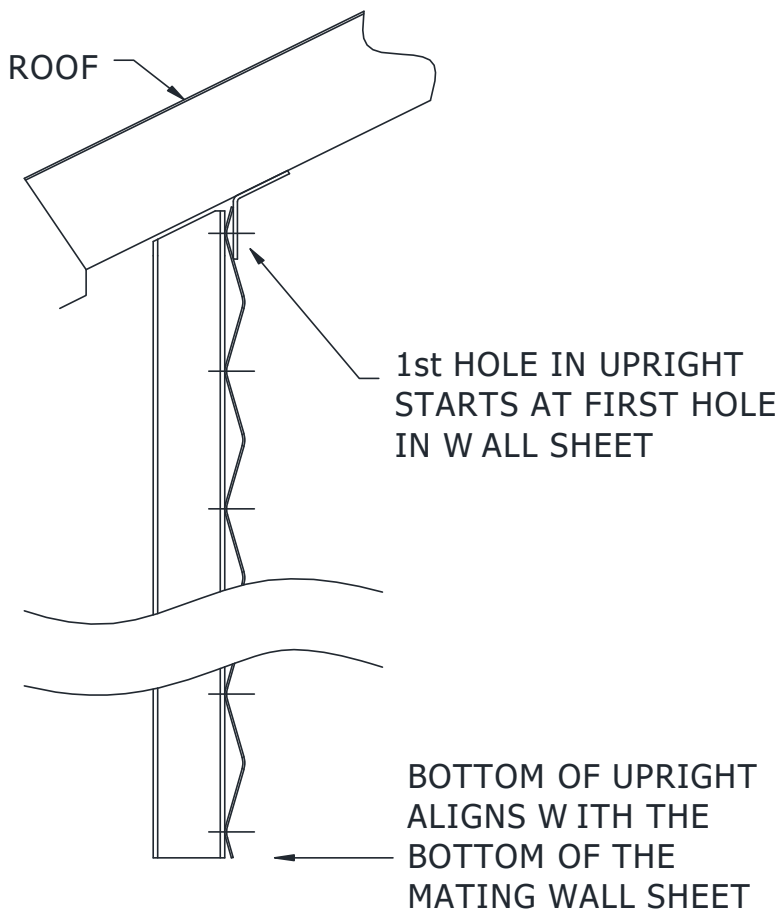

Table 15. Upright/Laminate Identification Table

	Identifying Letter	Part Number	Description	Gauge	Label Colour	Width of Section (in)
Uprights	S	232700S	Upright S .076" Short	14	Light green	5.5"
	A	232701A	Upright A .076" x 5.5"	14	Yellow	5.5"
	B	232702B	Upright B .076" x 5.5"	14	Light green	5.5"
	C	232703C	Upright C .116" x 5.5"	12	Blue	5.5"
	E	232705E	Upright E .168" x 5.5"	8	Brown	5.5"
	F	232706F	Upright F .168" x 6.5"	8	Silver	6.5"
	G	232707G	Upright G .168" x 10"	8	Gold	10"
Laminates	U	232713U	Laminate U .116" x 5.5"	12	Blue striped	5.5"
	W	232715W	Laminate W .168" x 5.5"	8	Brown striped	5.5"
	X	232716X	Laminate X .168" x 6.5"	8	Silver Striped	6.5"
	Y	232717Y	Laminate Y .168" x 10"	8	Gold striped	10"
Boxed	J	232709J	Upright Boxed J .168" x 10"	8	Red	10"
	K	232710K	Laminate Boxed K .168" x 10"	8	Red Striped	10"
	L	232711L	Laminate Boxed L .168" x 5.5"	8	Red Striped	5.5"

Note

Not all sections are used on all bins.

Figure 43. Upright and Laminate Components

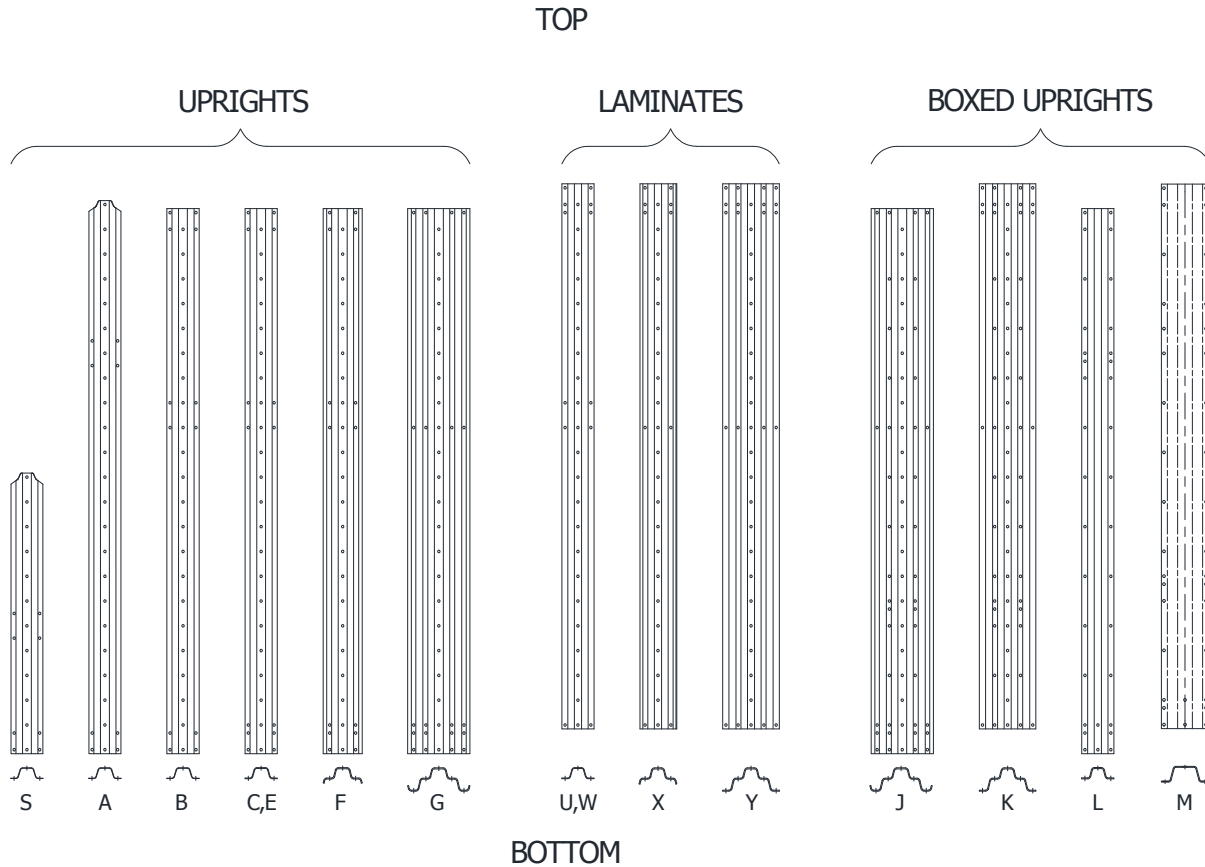

Catwalk Support Uprights

The upright/laminate requirements under catwalk support locations are likely different from the normal upright/laminate order. Consult your Westeel representative for specifications.

Bolt/Nut Orientation

To allow for a good seal install the bolts from the inside of the bin as shown for externally stiffened bins.

Upright/Splice Pre-Assemblies

At the top of a bin, laminates are not utilized and a splice is required to make the connection between mating uprights. The splice nests inside the upright similar to a laminate. When pre-assembling uprights to splices, insure that the splice goes on the top end of the upright, such that the label on the bottom of the upright remains visible. Keeping the label visible will help prevent subsequent errors. This practice will also prevent ground interference when adjusting jack locations.

Figure 44. Upright / Wall Sheet Bolt and Nut Orientation

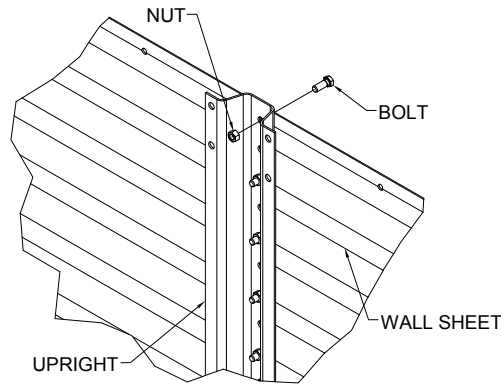

Tip

It may be advantageous to conduct pre-assemblies during the installation process. This can be a real time saver.

Figure 45. Pre-Assembling Uprights/Splices

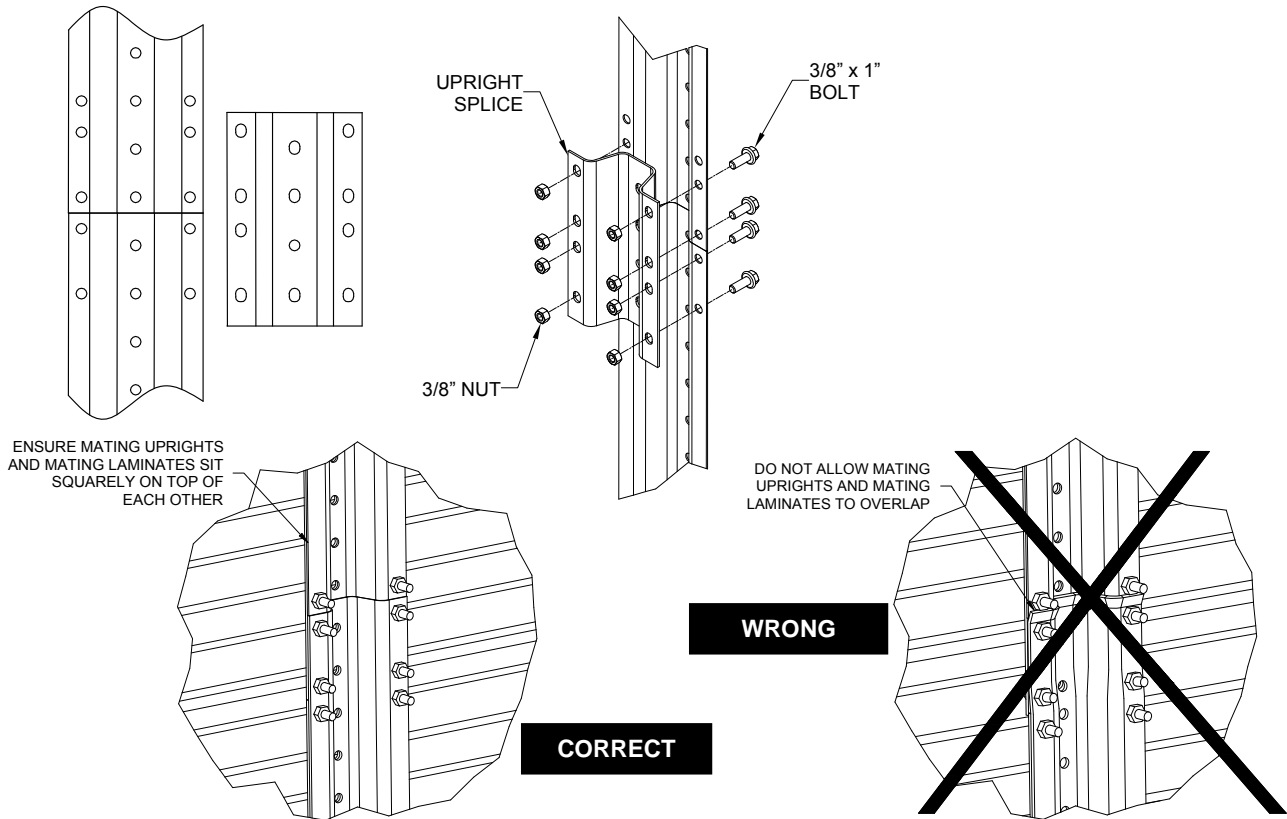

Upright and Laminate Assembly

Uprights and laminates are designed to transfer vertical loads through an end to end, butt connection. Ensure that mating uprights sit squarely on top of each other and do not overlap. Ensure that mating laminates sit squarely on top of each other and do not overlap. Secure the joints with the nuts and bolts provided. Failure to do so can result in structural failure.

Upright/Laminate Pre-assemblies

Laminates nest inside of uprights and are offset 4" above the uprights.

Figure 46. Nesting Laminates and Uprights

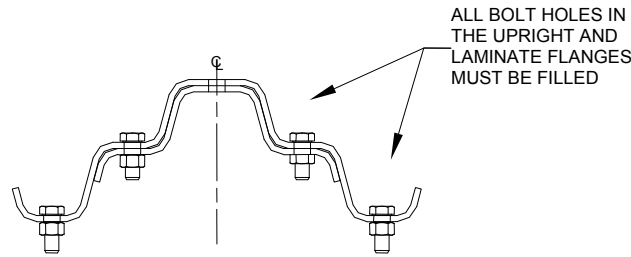

For proper orientation, ensure that the labels on the upright and laminate are both towards the bottom and that the locator holes in the middle portion of the upright and laminate line up. Bolts can be placed in these locator holes to create a pre-assembly. All locator holes, located in the middle of the upright and laminate flanges, need to be filled with bolts. These include holes in flanges that may only have one thickness of material.

Figure 47. Upright/Laminate Orientation

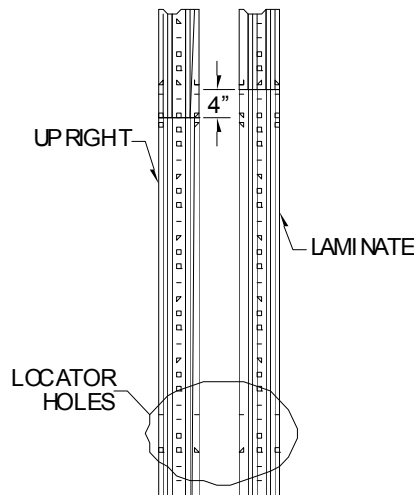

When properly assembled, both the upright label and the laminate label will remain visible during the pre-assembly phase. Once assembled on the bin the upright label will be covered.

In the assembly layouts, the combination of an upright and a laminate is called an assembly. For example, the combination of a “C” upright and a “U” laminate would be called a “CU Assembly”. Both the “C” on the upright label and the “U” on the laminate label, would remain visible, and would therefore remain distinguishable from other pre-assemblies.

Tip

When creating pre-assemblies, ensure that the labels on both the upright and the laminate are on the same end, and that the locator holes align with each other in the middle of the parts. Once pre-assembled, both labels should remain visible.

Note

Once completely assembled onto the bin, all visible holes in the upright and laminate flanges must be filled. All mating wall sheet/upright holes must be filled.

5.20.1 Base Assembly

Using 3/4" x 2-1/2" bolts attach the base plate to the compression ring. A 7/8" washer, 3/4" washer and 3/4" nut secure the base plate to the compression ring. At the bottom of an assembled bin that has laminates, there will be a 4" gap between the bottom laminate and the base plate. It is imperative that this area is filled with the 4" laminate section that protrudes from the base plate. In many cases this part can also be added to the bottom upright/laminate assembly during pre-assembly.

Figure 48. Base Assembly

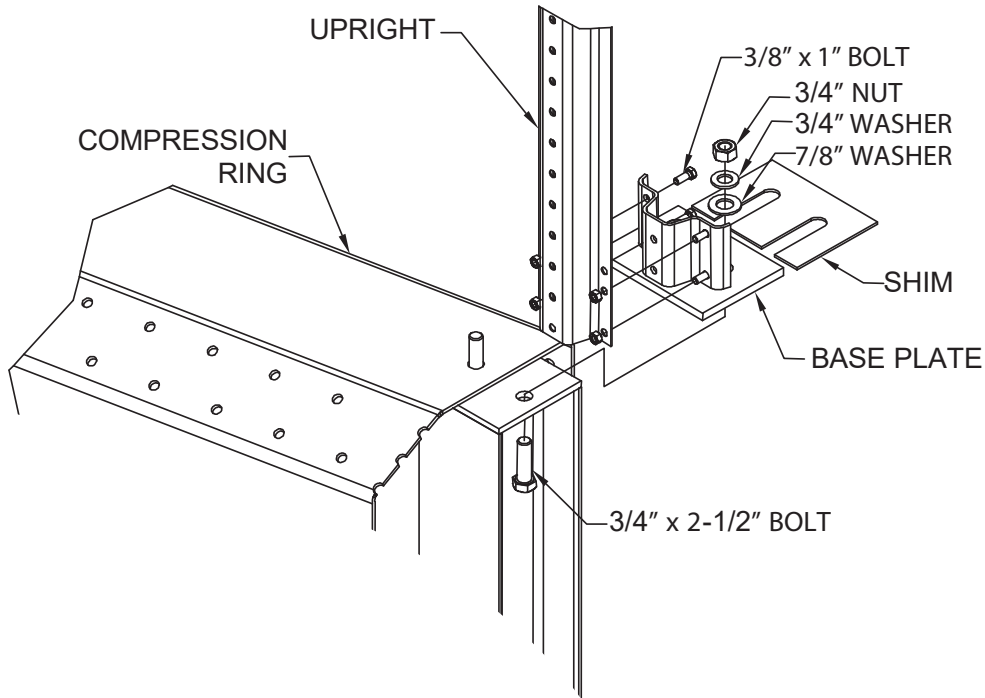

Tip

Depending on the assembly procedure, it may be convenient to bolt on the base plates to the compression ring.

5.21. Wind Ring Assembly

Wind rings fulfill their function when the bin is empty or partially filled. In high winds, the wind rings provide extra stiffness and help keep the bin round. Not all bins require wind rings. Bin diameter and height determine the location and the quantity of wind rings required.

Wind ring locations are identified by an O placed beside the relevant uprights within the wall sheet and upright layouts for the bin in question. At these locations wind ring tubes are secured to the upright flanges with a series of clips that bolt into the upright locator holes that are located in the flanges of the 5.5" wide upright and upright/laminate combinations. Adjacent tubes are aligned and secured to each other with wind ring splices. A 3/8" x 3-3/4" bolt through the splice keeps it centered on the connection.

Figure 49. Wind Ring Assembly

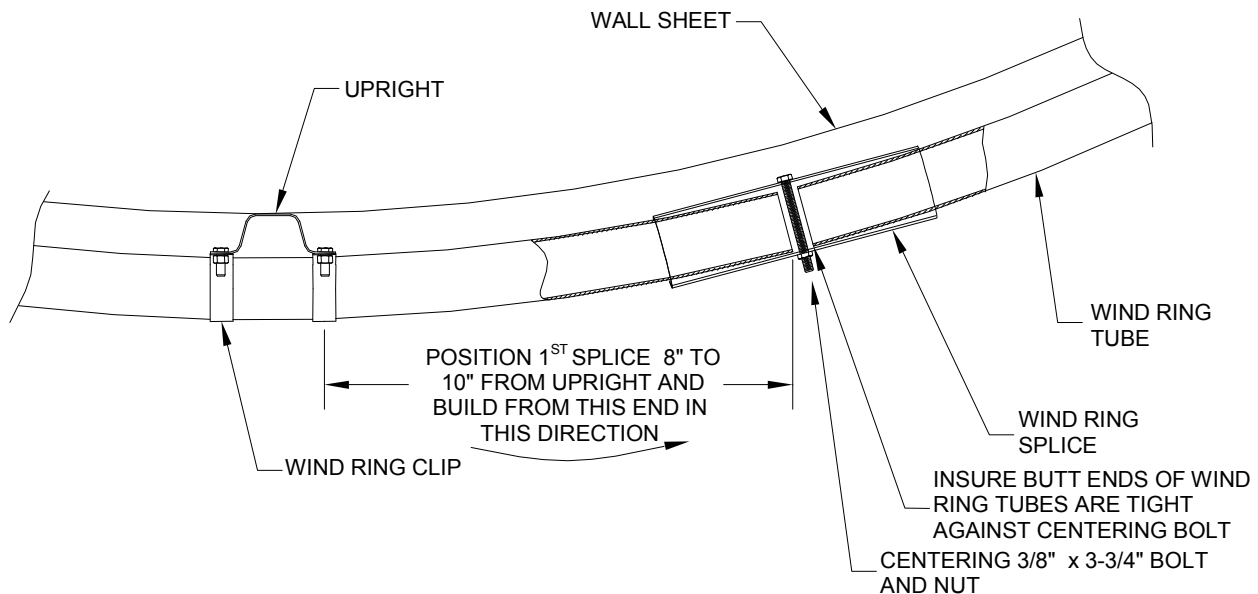

Externally Stiffened Bins

Once the uprights have been secured to the bin walls, position the first wind ring tube and secure it to the upright using the wind ring clips provided. Two clips are required per upright, one on each flange. Position the wind ring such that a wind ring splice (with bolt inserted) can be slipped onto the end of the tube without interfering with the upright or the wind ring clips. The splice should be orientated such that the bolt is horizontal.

Insert the end of the next wind ring tube into the open end of the wind ring splice. Insure that the ends of both tubes are tight against the centering bolt. Secure the wind ring tube to the uprights with the wind ring clips. Continue around the bin.

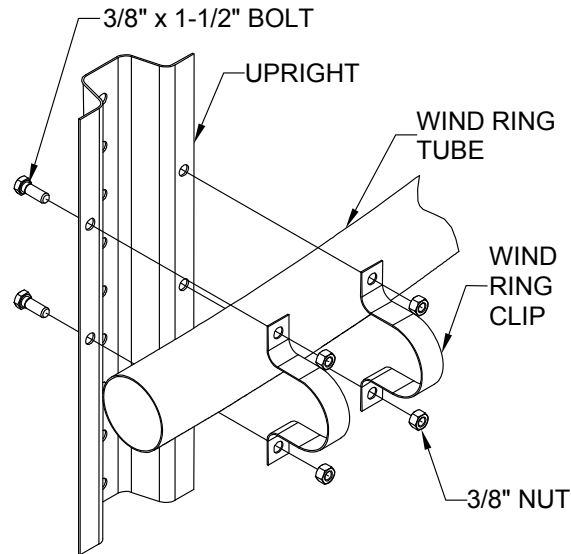
Figure 50. Wind Ring Mounting Detail (externally stiffened bins)

All wind ring splice connections should be made in the space between uprights, and should not encroach into the area where the wind ring clips are securing the wind ring tube to the uprights. To avoid interference with uprights and the need to make multiple cuts, position an end of the first tube relatively close to an upright, such that the space between the end of the tube and the next upright is maximized, and build from that end. Insure that both ends of the tube are far enough away from the closest uprights to avoid interference with the splice. When progressing around the bin, this space between the end of the tube and the next uprights may shrink with each additional tube that is installed. On large diameter bins, if this space shrinks to the point where the wind ring splice interferes with the upright, then the tube will need to be cut. Make the cut such that the space that is created between the end of the tube and the next upright is similar to the identical space on the first tube that was installed. In this manner, there will not be a shortage of tube.

Note

Assembly Tip: When putting the first wind ring tube in place, locate one end close to an upright with a 8" to 10" overhang, and continue building from that end. This will reduce the need for multiple cuts.

The final wind ring tube in a circle will need to be cut to length. Secure one end of the last tube in the previously installed wind ring splice as described above. Hold the tube in place and mark the cut-line relative to the previously installed tube at the other end. Insure that allowance is made for the 3/8" diameter bolt. Once the tube has been cut, install one end of the tube as described above. On the other end slide the wind ring splice completely onto the free end. Position this end relative to the previously installed tube, and slide the splice onto the second tube until it is centered. Insert the centering bolt. Install all wind ring clips. Tighten all bolts.

Note

Assembly Tip: When tightening wind ring clips, always tighten in sequence starting at the spliced end of the tube, which has already been secured, and work towards the free, and as yet unspliced, end.

5.22. Bin Jack Techniques

Figure 51. External Bin Jack Detail

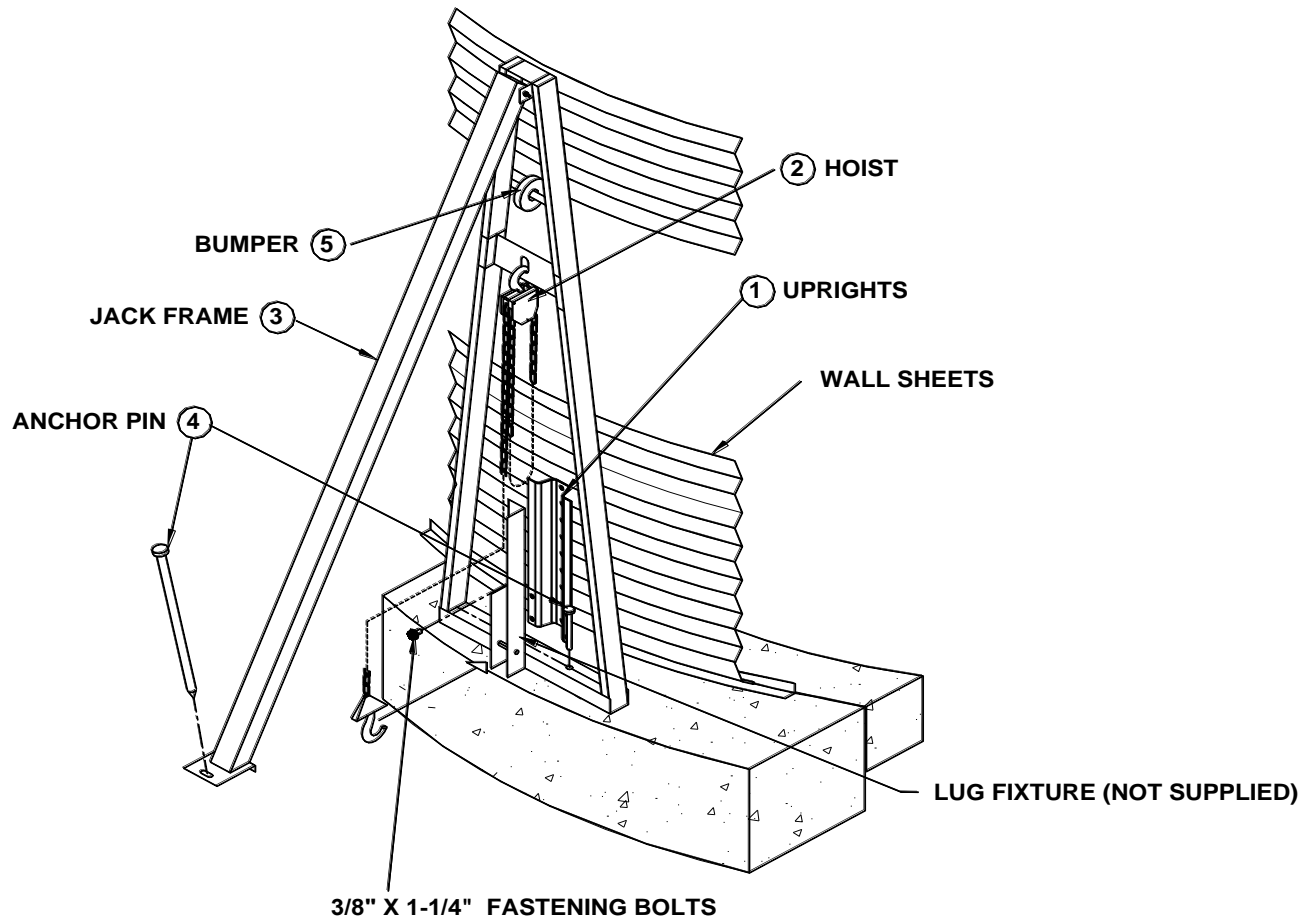

1. Choose a hoist with a suitable capacity for the expected load. Make sure the rated capacity of the hoist is not exceeded.
2. Fabricate custom lifting lugs to suit the assembly equipment. Each lug should have a capacity 5 times the expected load.
3. Have jacks evenly spaced around the bin. Use one jack per wall sheet. Each jack should have a capacity 5 times the expected load.
4. Anchor the jack securely. Use a guy wire if necessary to ensure stability.
5. Use a minimum of four 3/8" x 1-1/4" bolts (Grade 8), not supplied, to fasten lug, if one jack per wall sheet is used

Note

The bin may also be erected using an internal jacking system (**not available from Westeel**).

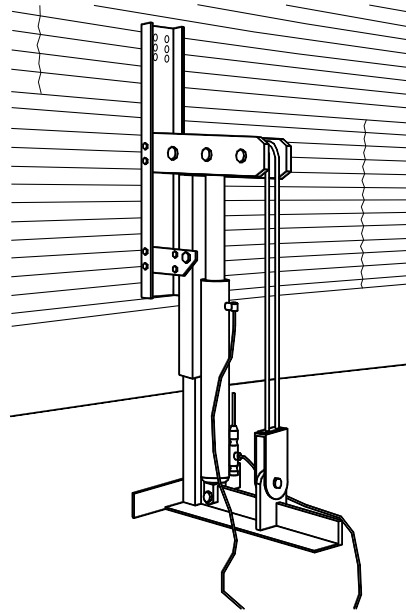
Figure 52. Internal Bin Jack Detail

We recommend:

- Ensure jacks are sized for the job. Do not exceed rated capacity.
- Layout jacks in a proper radius. Setting the jacks in the round makes the bin round.
- Use a minimum of one jack per wall sheet. Anchor them securely to the concrete.
- Jack on uprights. Hang wall sheets for two tiers until uprights are installed. Monitor hole alignment and make adjustments with a drift pin as you go, before tightening. Lifting the uprights towards one another during construction makes for easier realignment should misalignment creep in.

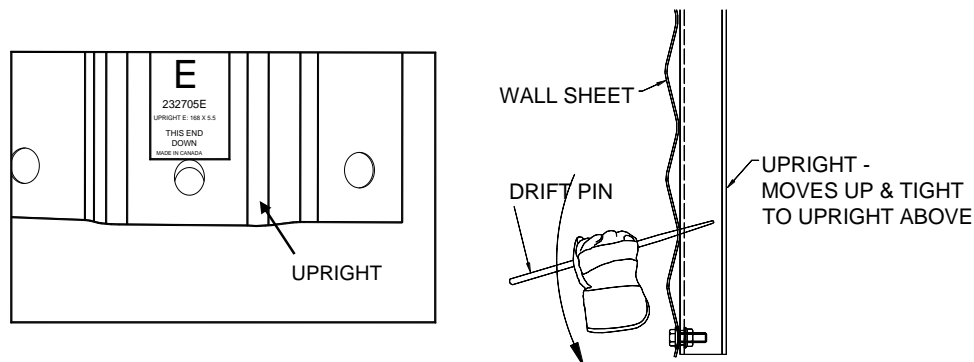
Figure 53. Hole Alignment

- Protect electrical cords.
- A drift pin is your friend. Use them for carrying wall sheets, aligning holes and forcing uprights up.

6. Specifications

6.1. Wide-Corr® Hopper Tank Specifications

Table 16. Wide-Corr® Hopper Tank Specifications Table

Model	Capacity			Estimated Weight (lbs)		Overall Height A	Eaves height B	Hopper Height C	Number of Legs	Hopper Angle	Bin Diameter D	Overall Diameter E	Peak Opening F
	Bushels	m ³	tonnes	Total	Tank Only								
1507H45	4,350	146	118	8,300	3,800	39' 6"	35' 7"	9' 9"	10	45°	14' 11"	15' 11"	33"
1508H45	4,890	165	133	8,600	4,200	43' 2"	39' 3"						
1509H45	5,440	183	147	9,300	4,800	46' 10"	42' 11"						
1510H45	5,980	201	162	9,800	5,300	50' 6"	46' 7"						
1511H45	6,520	219	177	10,400	6,000	54' 2"	50' 3"						
1512H45	7,060	237	192	11,000	6,500	57' 10"	53' 11"						
1513H45	7,600	255	206	11,600	7,100	61' 6"	57' 7"						
1807H45	6,440	217	175	10,500	4,500	42' 0"	37' 2"	11' 4"	12	45°	17' 11"	18' 11"	33"
1808H45	7,220	243	196	11,200	5,200	45' 8"	40' 10"						
1809H45	8,000	269	217	11,700	5,700	49' 4"	44' 6"						
1810H45	8,780	295	238	12,400	6,400	53' 0"	48' 2"						
1811H45	9,560	321	259	13,200	7,200	56' 8"	51' 10"						
1812H45	10,330	347	280	13,900	7,900	60' 4"	55' 6"						
1813H45	11,110	373	302	14,800	8,800	64' 0"	59' 2"						
2107H45	8,990	303	244	14,400	5,500	44' 5"	38' 9"	12' 11"	14	45°	20' 11"	21' 11"	33"
2108H45	10,050	338	273	15,100	6,200	48' 1"	42' 5"						
2109H45	11,140	374	302	15,900	7,000	51' 9"	46' 1"						
2110H45	12,170	409	330	16,700	7,800	55' 5"	49' 9"						
2111H45	13,230	445	359	17,700	8,800	59' 1"	53' 5"						
2112H45	14,290	481	388	18,500	9,600	62' 9"	57' 1"						
2113H45	15,360	516	417	19,700	10,800	66' 5"	60' 9"						
2407H45	12,040	405	327	17,500	6,300	46' 9"	40' 3"	14' 5"	16	45°	23' 11"	24' 11"	33"
2408H45	13,430	452	364	18,400	7,300	50' 5"	43' 11"						
2409H45	14,810	498	402	19,500	8,300	54' 1"	47' 7"						
2410H45	16,200	545	440	20,800	9,600	57' 9"	51' 3"						
2411H45	17,580	591	477	21,700	10,500	61' 5"	54' 11"						
2412H45	18,970	638	515	23,000	11,900	65' 1"	58' 7"						
2413H45	20,350	684	552	23,900	12,800	68' 9"	62' 3"						
2414H45	21,730	730	589	27,800	14,500	72' 5"	65' 11"						
2707H40	15,280	515	415	25,700	7,600	47' 0"	39' 7"	13' 9"	18	40°	26' 10"	27' 10"	33"
2708H40	17,030	573	462	26,400	8,300	50' 8"	43' 3"						
2709H40	18,790	632	510	28,000	9,900	54' 4"	46' 11"						
2710H40	20,540	691	557	29,700	11,600	58' 0"	50' 7"						
2711H40	22,290	750	605	30,800	12,700	61' 8"	54' 3"						
2712H40	24,050	809	652	32,400	14,300	65' 4"	57' 11"						
2713H40	25,800	868	700	33,900	15,800	69' 0"	61' 7"						
2714H40	27,550	927	748	36,700	17,600	72' 8"	65' 3"						
3007H40	19,280	649	523	30,700	8,700	49' 1"	40' 10"	15' 0"	20	40°	29' 10"	30' 10"	33"
3007H40	21,440	722	582	31,500	9,600	52' 9"	44' 6"						
3009H40	23,600	795	641	33,100	11,200	56' 5"	48' 2"						
3010H40	25,770	867	699	34,600	12,700	60' 1"	51' 10"						
3011H40	27,930	940	758	36,700	14,800	63' 9"	55' 6"						
3012H40	30,100	1,012	817	38,800	16,900	67' 5"	59' 2"						
3013H40	32,260	1,085	875	41,000	19,000	71' 1"	62' 10"						
3014H40	34,430	1,158	934	43,500	20,800	74' 9"	66' 6"						
3307H37	23,490	792	637	45,400	10,300	49' 7"	40' 11"	15' 1"	22	37°	32' 10"	33' 10"	52"
3308H37	26,110	880	708	46,400	11,300	53' 3"	44' 7"						
3309H37	28,730	967	779	48,100	13,000	53' 3"	48' 3"						
3310H37	31,350	1,055	851	49,600	14,500	60' 7"	51' 11"						
3311H37	33,960	1,143	922	52,300	17,200	64' 3"	55' 7"						

Table 16 Wide-Corr® Hopper Tank Specifications Table (continued)

Model	Capacity			Estimated Weight (lbs)		Overall Height A	Eaves height B	Hopper Height C	Number of Legs	Hopper Angle	Bin Diameter D	Overall Diameter E	Peak Opening F
	Bushels	m ³	tonnes	Total	Tank Only								
3312H37	36,580	1,231	993	55,000	19,900	67' 11"	59' 3"	16' 3"	24	37°	35' 10"	36' 10"	52"
3313H37	39,200	1,319	1,064	57,400	22,300	71' 7"	62' 11"						
3314H37	41,820	1,407	1,135	59,600	24,500	75' 3"	66' 7"						
3607H37	28,510	961	774	52,400	11,400	51' 7"	42' 1"						
3608H37	31,630	1,066	858	53,500	12,500	55' 3"	45' 9"						
3609H37	34,740	1,170	943	55,300	14,300	58' 11"	49' 5"						
3610H37	37,860	1,275	1,027	57,200	16,100	62' 7"	53' 1"						
3611H37	40,980	1,379	1,112	59,900	18,900	66' 3"	56' 9"						
3612H37	44,100	1,484	1,197	62,800	21,800	69' 11"	60' 5"						
3613H37	47,210	1,589	1,281	66,200	25,200	73' 7"	64' 1"						
3614H37	50,330	1,693	1,366	69,300	28,300	77' 3"	67' 9"						

Capacities are based on:

1. 28° roof cone
2. 1 bushel = 1.244 ft³
3. 1 m³ = 35.3 ft³
4. 770 kg/m³ bulk density
5. 6% compaction in hopper and cylinder (bushels and tonnes)

Figure 54. Wide-Corr® Hopper Tank Specifications Diagram

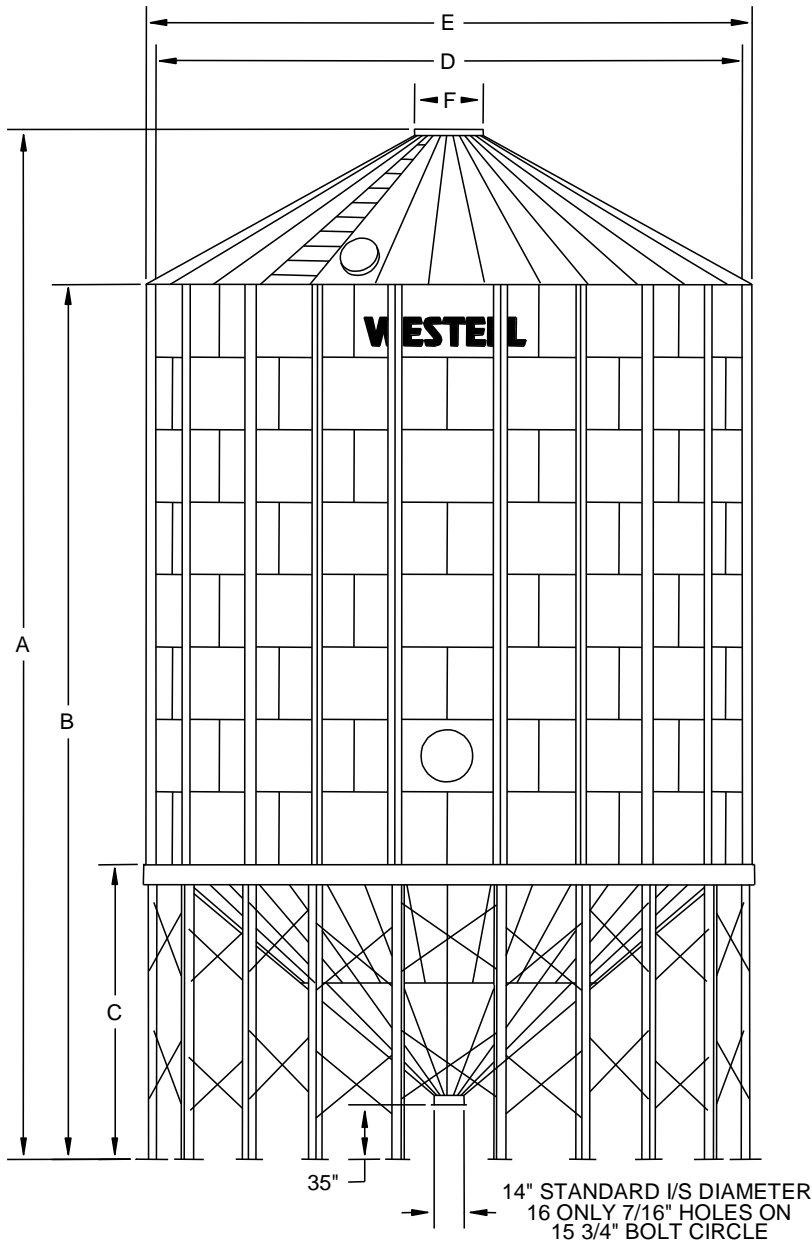

7. Appendix

7.1. Roof Parts Box Listing

Table 17. Roof Parts Box Part Identification

Part Number	Description	Unit Weight (lbs)	15'	18'	21'	24'	27'	30'	33'	36'
			235760	235761	235762	235763	235764	235765	235766	235767
212201	PEAK RING 15	30.7	1	-	-	-	-	-	-	-
212203	PEAK RING 18	30.7	-	1	-	-	-	-	-	-
212204	PEAK RING 21	30.7	-	-	1	-	-	-	-	-
212205	PEAK RING 24	30.7	-	-	-	1	-	-	-	-
212206	PEAK RING 27	30.7	-	-	-	-	1	-	-	-
Varies	PEAK RING (30' - 54')	-	-	-	-	-	-	-	-	-
212228	PEAK RING FOAM for 15-27, 51-54	0.4	1	1	1	1	1	-	-	-
212229	PEAK RING FOAM for 30-48	0.5	-	-	-	-	-	1	1	1
212230	BIRD STOP	0.127	15	18	21	24	27	30	33	36
212231	FOAM ROOF RIB CLOSURE (12)	0.06	2	2	2	2	3	3	3	3
170445	CAULKING - 300 ml TUBE	1	2	2	2	2	2	2	2	2
185010	CARTON 37x37x9 for BIN PARTS 15-27	9.4	1	1	1	1	1	-	-	-
185011	CARTON 53x27x7 for BIN PARTS 30-54	8.3	-	-	-	-	-	1	1	1
193062	LADDER RUNG 14.5 (6.0 CTR)	1	-	-	-	-	-	-	-	-
193063	LADDER RUNG 14.5 (8.0 CTR)	1	-	-	-	1	1	-	-	1
193064	LADDER RUNG 14.5 (10.0 CTR)	1	-	-	1	-	-	1	1	-
193065	LADDER RUNG 14.5 (12.0 CTR)	1	-	1	-	-	1	-	-	1
193066	LADDER RUNG 16.5 (14.0 CTR)	1.1	1	-	-	1	-	1	1	-
193067	LADDER RUNG 18.5 (16.0 CTR)	1.3	-	-	1	-	1	-	1	1
193068	LADDER RUNG 20.5 (18.0 CTR)	1.4	-	1	-	1	-	1	-	1
193069	LADDER RUNG 22.5 (20.0 CTR)	1.5	-	-	1	-	1	-	1	-
193070	LADDER RUNG 24.5 (22.0 CTR)	1.7	1	-	-	1	-	1	-	1
193071	LADDER RUNG 26.5 (24.0 CTR)	3.2	-	1	-	-	1	-	1	-
193072	LADDER RUNG 28.5 (26.0 CTR)	3.4	-	-	1	-	-	1	1	-
193073	LADDER RUNG 30.5 (28.0 CTR)	3.6	1	-	-	1	1	-	-	1
193074	LADDER RUNG 32.5 (30.0 CTR)	3.9	-	1	-	-	-	1	1	1
193075	LADDER RUNG 34.5 (32.0 CTR)	4.1	-	-	1	1	1	-	-	-
193076	LADDER RUNG 36.5 (34.0 CTR)	4.4	-	-	-	-	-	1	1	1
193077	LADDER RUNG 38.5 (36.0 CTR)	4.6	1	1	1	1	1	1	1	1
193078	LADDER RUNG 40.5 (38.0 CTR)	4.8	-	-	-	-	-	-	-	-
195063	STIFFENING RING BRACKET	0.31	-	-	-	-	-	-	33	36
195074	STIFFENING RING SPLICE 1.375	1.35	-	-	-	-	-	-	3	3
195080	STIFFENING RING GASKET - BAG 50	0.05	-	-	-	-	-	-	1	1
195085	STIFFENING RING EXPANDER 1.375	4.66	-	-	-	-	-	-	2	2
195149	PEAK RING BULB GASKET 105"	0.9	1	1	1	1	1	-	-	-
195150	PEAK RING BULB GASKET 168"	1.44	-	-	-	-	-	1	1	1
195695	DOOR TIE BACK CHAIN 17.75" LONG	0.52	1	1	1	1	1	1	1	1
212731	LOAD SPREADER TUBE 15	8.6	1	-	-	-	-	-	-	-

Table 17 Roof Parts Box Part Identification (continued)

Part Number	Description	Unit Weight (lbs)	15'	18'	21'	24'	27'	30'	33'	36'
			235760	235761	235762	235763	235764	235765	235766	235767
212732	LOAD SPREADER TUBE 18	8.6	-	1	-	-	-	-	-	-
212733	LOAD SPREADER TUBE 21	8.6	-	-	1	-	-	-	-	-
212734	LOAD SPREADER TUBE 24	8.6	-	-	-	1	-	-	-	-
212735	LOAD SPREADER TUBE 27	8.6	-	-	-	-	1	-	-	-
212736	LOAD SPREADER TUBE 30	8.6	-	-	-	-	-	1	-	-
212737	LOAD SPREADER TUBE 33-36	8.6	-	-	-	-	-	-	1	1
212738	LOAD SPREADER TUBE 39-45	8.6	-	-	-	-	-	-	-	-
212739	LOAD SPREADER TUBE 48-54	8.6	-	-	-	-	-	-	-	-
212740	FALL RESTRAINT BRACKET	0.3	2	2	2	2	2	2	2	2
212789	RUBBER PAD	0.06	2	2	2	2	2	2	2	2
232720	UPRIGHT SPLICE	2.14	1	1	1	1	1	1	1	1
232767	WIND RING CLIP	0.44	2	2	2	2	2	2	2	2
232798	STIFFENING RING EXPANDER CLIP	0.125	-	-	-	-	-	-	2	2
234157	U-BOLT, ROUND .312 x 1.75W x 2.8L	0.12	-	-	-	-	-	-	33	36
235151	SELFDRIILL SCREW .25 x 1.0 - BAG 7	0.13	-	-	-	-	-	-	1	1
235372	SEALING CLIP for BOTTOM ANGLE	0.12	5	6	7	8	9	10	11	12
235882	INSPECTION HATCH BULB GASKET 76"	0.5	1	1	1	1	1	1	1	1
235890	INSPECTION HATCH LID	7.48	1	1	1	1	1	1	1	1
235891	INSPECTION HATCH LATCH	0.81	1	1	1	1	1	1	1	1
235914	BOLT HFS .313 x 1.00 GR8.2 - BAG 250	8.5	1	1	1	2	2	2	3	3
235915	BOLT HFS .313 x 1.00 GR8.2 - BAG 50	1.7	-	1	3	-	-	2	-	2
235916	BOLT HFS .313 x 1.25 GR8.2 - BAG 80	3.04	1	-	-	1	1	2	2	1
235917	BOLT HFS .313 x 1.25 GR8.2 - BAG 50	1.9	-	2	2	1	1	-	-	2
235923	HEX FLANGE NUT .313 - BAG 250	3.5	1	2	2	2	3	3	4	4
235925	HEX FLANGE NUT .313 - BAG 50	0.7	3	-	1	3	-	1	-	3
235954	HEX FLANGE NUT .375 GR5 - Bag 300	5.7	-	-	-	-	-	-	-	-
235955	HEX FLANGE NUT .375 GR5 - Bag 50	0.95	2	2	2	2	3	3	3	3
235956	FLAT WASHER .375 - BAG 200	2.8	-	1	1	1	1	1	1	1
235957	FLAT WASHER .375 - BAG 75	1.05	2	-	-	-	-	1	1	1
235974	WSHR SEAL .375 STL/NEO - BAG 25	0.2	1	1	1	1	1	1	1	1
235973	WSHR SEAL .313 STL/NEO - BAG 25	0.1	1	1	1	1	1	1	1	1
Shaded items are not included in the parts box, rather they are shipped individually.										

7.2. Rib Cap Quantities

Table 18. Rib Cap Quantities

Roof Diameter (ft)	Cables Used	Tier							
		7	8	9	10	11	12	13	14
15	Peak Cables	212846 (2)	212846 (2)	212846 (2)	212846 (2)	212846 (2)	212846 (2)	212846 (2)	n/a
18	Peak Cables	212847 (2)	212847 (2)	212847 (2)	212847 (2)	212847 (2)	212847 (2)	212847 (2)	n/a
21	Peak Cables	212848 (2)	212848 (2)	212848 (2)	212848 (2)	212848 (2)	212848 (2)	212848 (2)	n/a
24	Perimeter Cables	212773 (6)	212773 (6)	212773 (6)	212773 (6)	212773 (6)	212833 (6)	212833 (6)	212833 (6)
27	Perimeter Cables	212774 (6)	212774 (6)	212774 (6)	212774 (6)	212834 (6)	212834 (6)	212834 (6)	212834 (6)
30	Perimeter Cables	212775 (6)	212775 (6)	212775 (6)	212835 (12)	212835 (12)	212835 (12)	212835 (12)	212835 (12)
33	Perimeter Cables	212836 (6)	212836 (6)	212836 (6)	212836 (6)	212836 (6)	212836 (6)	212836 (12)	212836 (12)
36	Peak Cables	212837 (2)	212837 (2)	212837 (2)	212837 (2)	212837 (2)	212837 (2)	212837 (2)	212837 (2)
36	Perimeter Cables	212837 (6)	212837 (6)	212837 (6)	212837 (6)	212837 (6)	212837 (6)	212837 (12)	212837 (12)

7.3. Roof Parts Box Part Identification

Table 19. Roof Parts Box Part Identification

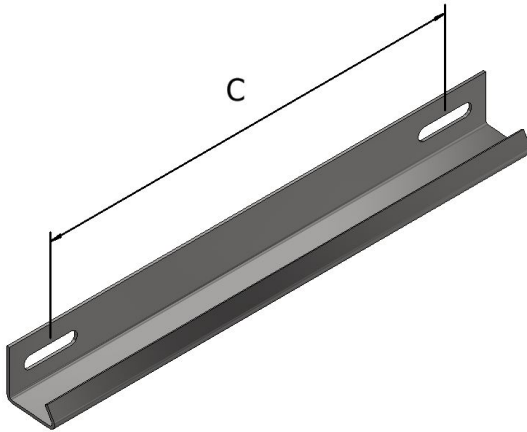

193061-78 – Roof Ladder Rung

P/N	C	P/N	C
193061	4	193071	24
193062	6	193072	26
193063	8	193073	28
193064	10	193074	30
193065	12	193075	32
193066	14	193076	34
193067	16	193077	36
193068	18	193078	38
193069	20		
193070	22		

"C" Dimension is in inches



195063 – Stiffening Ring Bracket

195080 – Stiffening Ring Gasket (Bag of 50)



194120 – Grain Gauge



195074 – Stiffening Ring Splice (1-3/8" Dia.)

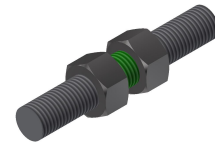

195085 – Stiffening Ring Expander (1-3/8" Dia.)



195149 – Peak Ring Bulb Gasket (105")

195150 – Peak Ring Bulb Gasket (168")

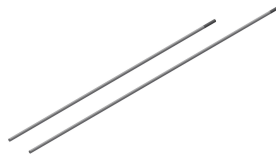

212400 - RCO Slide Rod (15' - 27') (45" Long)

212401 - RCO Slide Rod (30' - 54') (55" Long)

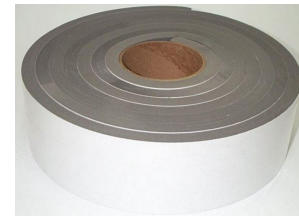

212228 – Peak Ring Foam Closure (15' - 27', 51' - 54')

212229 – Peak Ring Foam Closure (30' - 48')



212230 – Bird Stop



212231 – Roof Rib Foam Closure



195695 – Door Tie Back Chain (17-3/4" Long)

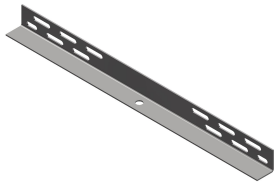

212402 – RCO Slide Rod Angle (15' - 48')



212403 – RCO Guide Rail (30' - 54') (51-7/8" Long)

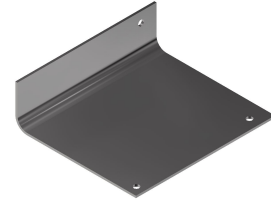

212404 – RCO Rope Guide Plate (15' - 27')

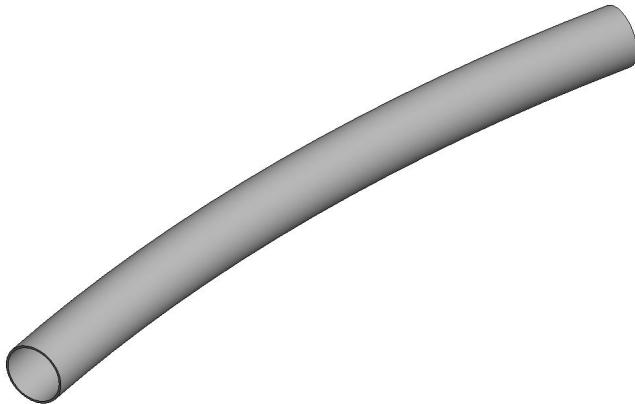

212731-39 — Load Spreader Tube

P/N	DIAMETER
212731	15
212732	18
212733	21
212734	24
212735	27
212736	30
212737	33 - 36
212738	39 - 45
212739	48 - 54



212740 – Fall Restraint Bracket

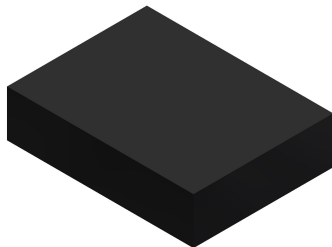

212789 - Rubber Pad



232720 – Upright Splice

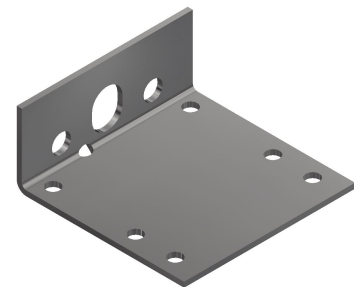

232735 – Anchor Bracket

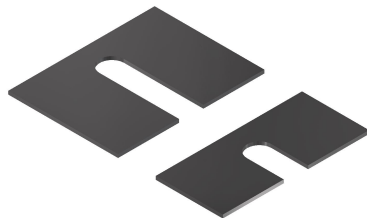

232736 – Shim (4-1/2" x 6")
232737 – Shim (2-3/4" x 6")



232767 – Wind Ring Clip



232798 - Stiffening Ring Expander Retaining Clip

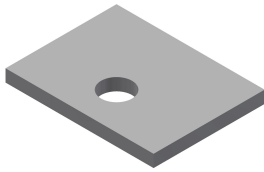

232836 – Base Plate



235009 – RCO Hardware Package (15' - 27')

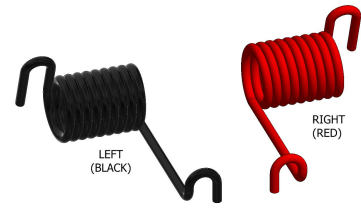

235012-13 – RCO Spring (15' - 27')

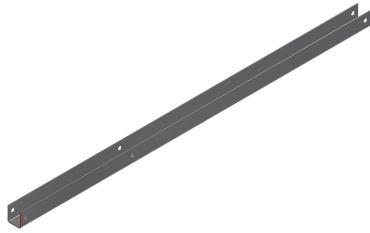

235218 – RCO Rope Arm (36")

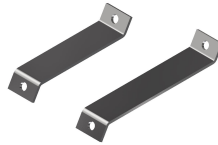

235219 - RCO Rope Arm Support (15' - 27')

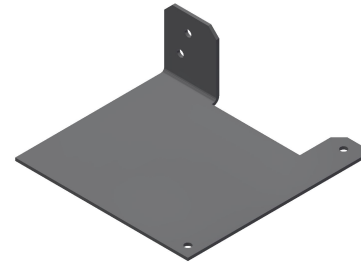

235279 – RCO Rope Guide Plate (30' - 54')

235220 - RCO Rope Arm Support (30' - 54')



235332 – RCO Pivot Arm Bracket (15' - 27')

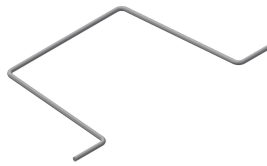

235333 – RCO Pivot Arm (15' - 27')



235335 – RCO Hardware Bag (30' - 48')



235337 - RCO Pivot Arm Bracket (30' - 48')

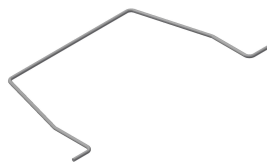

235338 – RCO Pivot Arm (30' - 54')

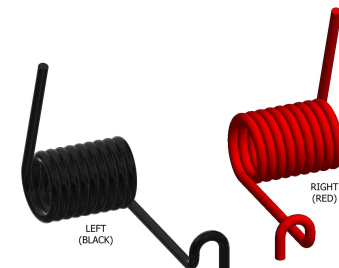

235341-42 – RCO Spring (30' - 54')

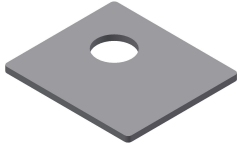

235372 – Bottom Angle Sealing Clip

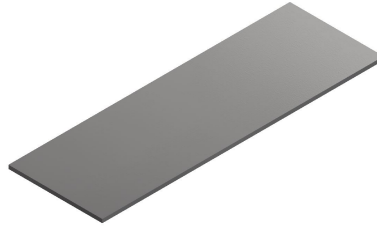

236583 – SSK Shim (6" x 2")



235882 – Inspection Hatch Bulb Gasket

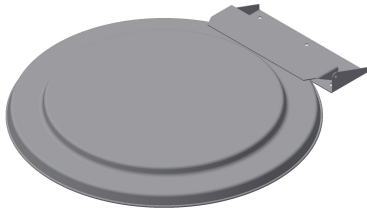

235890 – Inspection Hatch Lid Assembly



235891 – Inspection Hatch Latch Assembly

7.4. Hardware Usage

Table 20. Roof Hardware

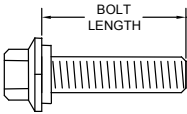
	1/4" x 1" Self Drilling Screw	5/16" x 1" Flanged Hex Bolt (Washer)	5/16" x 1-1/4" Flanged Hex Bolt (Washer)	5/16" Flanged Lock Nut	5/16" STL/NEO Sealing Washer	3/8" x 1-1/2" Flanged Hex Bolt (Washer)	3/8" Hex Nut	3/8" STL/NEO Sealing Washer
	235151 (7)	235914 (250) 235915 (50)	235916 (80) 235917 (50)	235923 (250) 235925 (50)	235973 (25)	235946 (100) 235935 (55)	232850 (700) 235950 (300) 235951 (100)	235974 (25)
TOP RING ANGLE to WALL SHEET			•	•				
ROOF SHEET to PEAK RING		•		•				
ROOF SHEET to TOP RING ANGLE		•		•				
ROOF SHEET RIB to ROOF SHEET RIB		•		•				
LADDER RUNG to ROOF SHEET RIB			•	•	•			
STIFFENING RING BRACKET to ROOF SHEET RIB			•	•				
RIB CAP to TWO ROOF SHEET RIBS		•		•				
RIB CAP SPLICE to RIB CAP to TWO ROOF SHEET RIBS		•		•				
STIFFENING RING BRACKET to RIB CAP to TWO ROOF SHEET RIBS			•	•				
STIFFENING RING EXPANDER CLIP to STIFFENING RING	•							
ROOF VENT to ROOF SHEET VENT CUTOUT		•		•				
INSPECTION HATCH LID ASSEMBLY to ROOF SHEET HATCH CUTOUT		•		•				
INSPECTION HATCH LATCH to ROOF SHEET		•		•	•			
ROOF SHEET to PEAK RING to FALL RESTRAINT BRACKET		•		•				
WIND RING CLIP to WALL SHEET to UPRIGHT SPLICE						•	•	•
FALL RESTRAINT BRACKET to UPRIGHT SPLICE		•		•				
BIRD STOP to TOP RING ANGLE		•		•				

Note

For structural roof hardware usage, please refer to **Structural Roof Manual (212453)**.

Table 21. Bin Hardware

	3/8" x 1" Flanged Hex Bolt (Washer)	3/8" x 1" Round Head Bolt	3/8" x 1-1/2" Flanged Hex Bolt (Washer)	3/8" x 3-3/4" Hex Bolt	3/8" Flanged Lock Nut	3/8" Hex Nut	3/8" Wingnut	3/8" Flat Washer	3/8" STL/NEO Sealing Washer	7/16" x 1-1/2" Flanged Hex Bolt (Washer)	7/16" x 1-3/4" Flanged Hex Bolt (Washer)	7/16" Hex Nut	1/2" Flat Washer
	232850 (700) 235941 (325) 235943 (50)	150594	232852 (500) 235946 (100)	235949 (10)	235954 (300) 235955 (50)	232850 (700) 232852 (500) 235950 (300) 235951 (100)	154208	235956 (200) 235957 (75)	235975 (100)	232855 (400)	232856 (300)	232855 (400) 232856 (300)	154981
INSIDE ROOF CONNECTOR UPRIGHT to WALL SHEET to OUTSIDE UPRIGHT (DOUBLE NUT)			•		•	•			•				
WALL SHEETS 194679 to 194685, and 194606 to 194607 (0.040" to 0.139")	•					•		•☀					
WALL SHEET 194608 (0.168")			•			•		•☀					
UPRIGHT to WALL SHEETS 194679 to 194685 (0.040" to 0.116")	•					•							
UPRIGHT to WALL SHEETS 194606 to 194608, and 194604 to 194618 (0.126" to 0.168", AND 0.096" LAM to 0.139" LAM)			•			•							
WALL SHEETS 194604 to 194605, and 194616 to 194617 (0.096" LAM to 0.139" LAM)										•		•	•♦
WALL SHEET 194618 (0.168" LAM)											•	•	•♦
UPRIGHT to WALL SHEET AT HORIZONTAL SEAMS			•			•							
UPRIGHT to LAMINATE to CAP PLATE to WALL SHEET (FOR BINS WITH BOXED UPRIGHTS ONLY)			•			•							
UPRIGHT to UPRIGHT SPLICE	•					•							
UPRIGHT to LAMINATE	•					•							
UPRIGHT to LAMINATE to BOXED UPRIGHT			•			•							
WALL SHEET to UPRIGHT to LAMINATE to CAP PLATE (FOR BINS WITH BOXED UPRIGHTS)			•			•							

Table 21 Bin Hardware (continued)

	3/8" x 1" Flanged Hex Bolt (Washer)	3/8" x 1" Round Head Bolt	3/8" x 1-1/2" Flanged Hex Bolt (Washer)	3/8" x 3-3/4" Hex Bolt	3/8" Flanged Lock Nut	3/8" Hex Nut	3/8" Wingnut	3/8" Flat Washer	3/8" STL/NEO Sealing Washer	7/16" x 1-1/2" Flanged Hex Bolt (Washer)	7/16" x 1-3/4" Flanged Hex Bolt (Washer)	7/16" Hex Nut	1/2" Flat Washer
	232850 (700) 235941 (325) 235943 (50)	150594	232852 (500) 235946 (100)	235949 (10)	235954 (300) 235955 (50)	232850 (700) 232852 (500) 235950 (300) 235951 (100)	154208	235956 (200) 235957 (75)	235975 (100)	232855 (400)	232856 (300)	232855 (400) 232856 (300)	154981
WIND RING CLIP to UPRIGHT			•			•							
WIND RING SPLICE				•		•							
WALL SHEET to BOTTOM RING ANGLE	•				•	•		•					
DRYING FLOOR FLASHING HOLES in BOTTOM WALL SHEET	•					•							
WALL SHEET to DOOR			•			•		•☀					
DOOR TIE-BACK to WALL SHEET	•					•							
AUGER CHUTE HOOD to AUGER DOOR BOARD		•				•							
AUGER CHUTE BLOCK-OFF PLATE to AUGER DOOR BOARD			•			•	•						
BIN WALL to HOPPER ASSEMBLY			•			•		•					

Note

- ☀ — Use washers only at wall sheet to bottom ring angle, non-laminated to laminated wall sheet horizontal seam and wall sheet vertical seams to door (non-laminated sheets only; 3/8" bolts).
- ◆ — Use washers only at wall sheet to bottom ring angle.

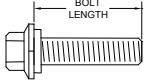
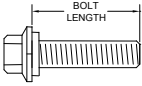
Table 22. Hopper Hardware (3/8" – 1/2")

	3/8" x 1" flanged hex bolt (washer)	3/8" x 1-1/2" flanged hex bolt (washer)	3/8" hex nut	3/8" flat washer	1/2" x 1" flanged hex bolt	1/2" x 1-1/2" flanged hex bolt	1/2" flanged lock nut	1/2" flat washer
	232850 (700) 235941 (325) 235943 (50)	232852 (500)	232850 (700) 232852 (500) 235950 (300) 235951 (100)	235956 (200) 235957 (75)	193781	193782	154201	154981
WALL SHEET to HOPPER COMPRESSION RING ASSEMBLY		•	•	•				
HOPPER COMPRESSION RING ASSEMBLY to UPRIGHT to WALL SHEET		•	•	•				
HOPPER FLASHING to WALL SHEET	•		•					
HOPPER SHEET to HOPPER SHEET (15' - 24')					•		•	
LOWER HOPPER SHEET to UPPER HOPPER SHEET (21' - 30')					•		•	
LOWER HOPPER SHEET to LOWER HOPPER SHEET (27' - 36')					•		•	
HOPPER SHEET to DISCHARGE CONE (15' - 30')					•		•	
HOPPER COMPRESSION RING ASSEMBLY to OUTSIDE and INSIDE SPLICE ANGLES (15' - 24')					•		•	
HOPPER COMPRESSION RING ASSEMBLY to TOP CORNER OF HOPPER SHEET (15' - 24')						•	•	•
HOPPER COMPRESSION RING ASSEMBLY to UPPER HOPPER SHEET (27' - 30')						•	•	
LOWER HOPPER SHEET to DISCHARGE CONE (33' - 36')						•	•	
HOPPER COMPRESSION RING ASSEMBLY to UPPER CHANNEL (27' - 30')						•	•	

Table 23. Hopper Hardware (5/8" – 7/8")

	5/8" x 1-1/2" flanged hex bolt	5/8" x 2" flanged hex bolt	5/8" hex nut	5/8" lock washer	3/4" x 2" hex bolt	3/4" x 2-1/2" hex bolt	3/4" hex nut	3/4" flat washer	7/8" flat washer
	193793	193796	154216	154990	150038	150591	150041	154978	154979
HOPPER COMPRESSION RING ASSEMBLY to UPPER CHANNEL (33' - 36')	•		•						
UPPER CHANNEL to SUPPORT COLUMN ASSEMBLY	•		•						
LOWER CHANNEL to SUPPORT COLUMN ASSEMBLY	•		•						
UPPER HOPPER SHEET to UPPER HOPPER SHEET (27' - 36')	•		•						
UPPER HOPPER SHEET to UPPER HOPPER SHEET to SPLICE SHIM to SPLICE PLATE or SPLICE ANGLE (36')	•		•						
UPPER HOPPER SHEET AT CORNERS to LOWER HOPPER SHEET (27' - 30')	•		•						
LOWER HOPPER SHEET to UPPER HOPPER SHEET (33' - 36')	•		•						
HOPPER COMPRESSION RING ASSEMBLY to OUTSIDE and INSIDE SPLICE PLATES to SUPPORT COLUMN ASSEMBLY (27' - 36')		•	•						
HOPPER COMPRESSION RING ASSEMBLY to UPPER HOPPER SHEET to SPLICE ANGLE (27' - 36')		•	•						
TIE ROD ENDS (15' - 24')			•	•					
HOPPER COMPRESSION RING ASSEMBLY to SUPPORT COLUMN ASSEMBLY (15' - 24')					•		•		
UPRIGHT BASE ASSEMBLY to HOPPER COMPRESSION RING ASSEMBLY to SUPPORT COLUMN ASSEMBLY						•	•	•	•
TIE ROD ENDS (27' - 36')							•	•	•

7.5. Recommended Bolt Assembly

When tightening bolts, tighten the nut on the bolt until a “snug-tightened condition” has been achieved. A “snug-tightened condition” is defined in *Specification for Structural Joints Using ASTM A325 or A490 Bolts* (Research Council on Structural Connections: June 2004), which states:

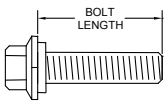
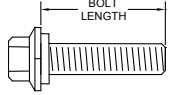





“The snug-tightened condition is the tightness that is attained with a few impacts of an impact wrench or the full effort of an ironworker using an ordinary spud wrench to bring the connected plies into firm contact.”

A properly tightened bolt will compress the sealing washer noticeably. All assembly crew members must be made aware of this requirement, and must know how to achieve a snug-tightened condition using common bin-building tools.

It is important that the bolts in the vertical wall sheet seams are tightened enough to squeeze the caulking and bring the wall sheet surfaces into firm contact with each other. This is especially important to monitor when installing bolts in temperatures approaching -10°C (14°F).

The following table shows the minimum impact gun torque capacity necessary to achieve a snug-tightened condition for bolts used in the assembly process.

Table 24. Recommended Impact Gun Torque Values Capacity to Achieve Snug-Tightened Bolts

Bolt Diameter	Bolt Grade	Grade Mark	Recommended Torque Capacity		
			in-lb	ft-lb	N-m
1/4"	Grade 8.2		75	6	8
5/16"	Grade 8.2		215	18	24
3/8"	Grade 8.2		370	31	42
7/16"	Grade 8.2		600	50	68
1/2"	Grade 8.2		960	80	108
5/8"	Grade 8.2		1800	150	203
3/4"	Grade 5		3230	269	365

For proper sealing, do not overtighten the wall seam connections. Sealing is not critical on upright splice connections; these connections should be tightened securely to prevent loosening.

Hold the bolt head securely when tightening the nut to prevent damage to the sealing washer.

Important

Always tighten the nut, not the bolt.

Avoid bin assembly at temperatures below -10°C (14°F) if possible. Erection in low temperatures does not ensure strong, well sealed connections. Do not substitute bolts in place of those supplied by Westeel.

8. Limited Warranty: Westeel Grain Bin Products

Westeel – Ag Growth International ("Westeel") warrants products that it has manufactured and/or that are branded with its name (the "goods") subject to the following terms and limitations, (the "warranty"):

Duration of Warranty

This warranty will run from the date of purchase from the dealer or distributor, authorized by Westeel. The duration of the warranty is limited as follows:

Galvanized Bins	5 years
EasyFlow2	24 months
Westeel Fans	36 months
Floors	12 months
Catwalk	12 months
Bulk Feed Tanks	24 months
SeedStor-K Cones	
Paint	12 months
Structural	30 months
Elite Cones	
Paint	30 months
Structural	10 years
WESTEEL cones	
Paint	No Warranty
Structural	12 months
Smooth Wall Bins	
Paint	60 months
Structural	10 years
Commercial Smooth Wall Bins	
Paint	12 months
Structural	10 years

Limitation of Remedies Replacement

Within the warranty period, Westeel will replace the goods and/or original manufactured components thereof which are found, to Westeel's satisfaction, to be defective. Westeel is not responsible for direct, indirect, special, consequential, or any other damages of any kind, including personal injury to any individual, howsoever caused, including caused by transportation of the goods for repair or replacement.

Procedure for Obtaining Service

In the event of a warranty claim, the purchaser must complete any and all information required by Westeel in order to properly assess or investigate the claim. Westeel will not be responsible for the removal of any of the goods found to be defective, or transportation charges to and from Westeel's authorized dealer or distributor, or for installation of any replacement goods and/or parts furnished under the warranty.

Limitations as to Scope of Warranty

The warranty does not extend to defects or damage caused, in whole or in part, by:

1. use of a kind and/or to a degree not reasonably expected to be made of the goods;
2. improper storage of the goods both prior to and after purchase;
3. damage caused by, or in the course of, installation or assembly;
4. any use of the goods which is not an intended use as specified in Westeel's published product literature, or otherwise specified by Westeel in writing;
5. any equipment attached to or used in conjunction with the goods;
6. any field modifications or substitutions to original bin components;
7. inadequate ventilation or any other circumstance not in keeping with proper maintenance and/or use of the goods;
8. Acts of God, accident, neglect or abuse of the goods by the purchaser and/or any other individual or entity; or
9. Any use or installation inconsistent with Westeel's Standard Disclaimers.

Limitations as to Manufacturer

The warranty does not cover products sold by Westeel that are not manufactured by Westeel. In those circumstances, the purchaser is referred to the manufacturer of those products.

Limitation of Implied Warranties and Other Remedies

To the extent allowed by law, neither Westeel nor its dealers, nor any company affiliated with Westeel makes any warranties, representations, or promises as to the quality, performance, or freedom from defect of any Product covered by this Warranty.

WESTEEL HEREBY DISCLAIMS, TO THE EXTENT APPLICABLE, ANY AND ALL IMPLIED WARRANTIES OF MERCHANTABILITY AND FITNESS FOR A PARTICULAR PURPOSE. A PURCHASER'S ONLY REMEDIES IN CONNECTION WITH THIS WARRANTY ARE THOSE SET FORTH IN THIS WARRANTY. IN NO EVENT WILL WESTEEL, ITS DEALERS, OR ANY COMPANY AFFILIATED WITH WESTEEL BE LIABLE FOR INCIDENTAL, CONSEQUENTIAL OR PUNITIVE DAMAGES.

Some jurisdictions do not allow waivers of certain warranties, so the above waivers may not apply to you. In that event, any implied warranties are limited in duration to ninety (90) days from delivery of the products. You may also have other rights which vary from jurisdiction to jurisdiction.

Exclusive Warranty

This warranty is the only warranty provided by Westeel and all other warranties and/or commitments, whether express or implied and no matter by whom made, statutory or otherwise, are subsumed and replaced by it and are of no legal effect. If any provision of the warranty is held by a court of

competent jurisdiction to be void or unenforceable, in whole or in part, such provision shall be deemed severable and will not affect or impair the legal validity of any other provision of the warranty.





Westeel is an AGI Brand.

AGI is a leading provider of equipment solutions for agriculture bulk commodities including seed, fertilizer, grain, and feed systems with a growing platform in providing equipment and solutions for food processing facilities. AGI has manufacturing facilities in Canada, the United States, the United Kingdom, Brazil, South Africa, India and Italy and distributes its products globally.



Westeel Head Office Box 792, Winnipeg, Canada R3C 2N5

P 888.WESTEEL (937.8335) or 204.233.7133 | E customerservice.winnipeg@westeel.com | westeel.com

AGGROWTH.COM [aggrowthintl](#)     

©Ag Growth International Inc. 2022 | Printed in Canada

If you have any comments or questions on this manual, or find an error, email us at comments@aggrowth.com. Please include the part number listed on the cover page in your message.