



# Top-Drive Field Loader

## Portable Grain Belt Conveyor Operator's Manual

This manual applies to:

HCX1535FLTD HCX1545FLTD

Electric and Hydraulic Drives

Original Instructions



Read this manual before using product. Failure to follow instructions and safety precautions can result in serious injury, death, or property damage. Keep manual for future reference.

Part Number: P1512145 R0

Revised: May 2018





# CONTENTS

- 1. Introduction ..... 5**
  - 1.1. Serial Number Location..... 5
  - 1.2. Intended Use ..... 5
    - 1.2.1 Misuse ..... 6
- 2. Safety..... 7**
  - 2.1. Safety Alert Symbol and Signal Words..... 7
  - 2.2. General Product Safety ..... 7
  - 2.3. Overhead Power Lines ..... 8
  - 2.4. Moving Conveyor Belt Safety..... 8
  - 2.5. Upending ..... 8
  - 2.6. Rotating Parts Safety..... 8
  - 2.7. Work Area Safety ..... 8
  - 2.8. Guards Safety ..... 10
  - 2.9. Raising and Lowering the Conveyor..... 11
  - 2.10. Hand Winch Safety..... 11
  - 2.11. Conveyor Stability ..... 11
  - 2.12. Towing the Conveyor ..... 12
  - 2.13. Drives and Lockout Safety..... 12
    - 2.13.1 Electric Motor Safety..... 13
    - 2.13.2 Hydraulic Power Safety ..... 14
  - 2.14. Tire Safety..... 15
  - 2.15. Personal Protective Equipment..... 15
  - 2.16. Safety Equipment ..... 16
  - 2.17. Safety Decals ..... 16
    - 2.17.1 Decal Installation/Replacement..... 16
    - 2.17.2 Safety Decal Locations and Details ..... 17
- 3. Features..... 25**
  - 3.1. Model Number ..... 26
- 4. Transport..... 27**
  - 4.1. Transport Safety ..... 27
  - 4.2. Transport Preparation ..... 27
  - 4.3. Connect the Conveyor to the Towing Vehicle ..... 28
- 5. Placement ..... 29**
  - 5.1. Placement Safety..... 29
  - 5.2. Positioning the Conveyor ..... 29
  - 5.3. Hand Winch Operation ..... 30
  - 5.4. Collapsible Hopper Cloth Control..... 31
  - 5.5. Conveyor Operating Angles ..... 31
- 6. Operation ..... 34**
  - 6.1. Operation Safety ..... 34
  - 6.2. Start-up and Break-in ..... 34
  - 6.3. Operation - Electric Motor Models..... 35
  - 6.4. Operation - Hydraulic Motor Models ..... 35
  - 6.5. Loading Area..... 35
  - 6.6. Conveyor Belt Speed ..... 36

- 6.7. Emergency Shutdown ..... 36
- 6.8. Restarting with a Full Tube ..... 36
- 6.9. Shutdown ..... 37
- 6.10. Clean Out..... 37
- 6.11. Conveying Fertilizer..... 37
- 6.12. Storage..... 39
  
- 7. Maintenance ..... 40**
  - 7.1. Maintenance Safety ..... 40
  - 7.2. Maintenance Schedule..... 40
  - 7.3. Visually Inspect the Equipment..... 41
  - 7.4. Lubricate the Equipment..... 42
  - 7.5. Oil the Chain Coupler ..... 42
  - 7.6. Inspect Hydraulic Hoses and Fittings ..... 42
  - 7.7. Inspect the Hopper Flashing ..... 43
  - 7.8. Check the Roller Bearings ..... 43
  - 7.9. Check the Roller Lagging ..... 43
  - 7.10. Tension the Conveyor Belt..... 43
    - 7.10.1 Top Drive Pinch Roller..... 44
  - 7.11. Align the Conveyor Belt..... 45
    - 7.11.1 Adjust the Rollers ..... 46
    - 7.11.2 Adjust the Belt Return Wear Blocks..... 47
  - 7.12. Inspect Belt Lacing..... 48
  - 7.13. Replace the Belt Lacing ..... 48
  - 7.14. Replace the Conveyor Belt..... 48
  - 7.15. Clean and Wash the Equipment ..... 50
  - 7.16. Tension the Drive Belts ..... 50
  - 7.17. Align the Drive Belts..... 51
  - 7.18. Replace the Drive Belts ..... 51
  - 7.19. Repack the Wheel Bearings with Grease..... 51
  - 7.20. Inspect and Service the Hand Winch and Lift Cable..... 52
  
- 8. Troubleshooting..... 53**
  
- 9. Specifications ..... 56**
  
- 10. Hutchinson/Mayrath Warranty ..... 57**

# 1. Introduction

Thank you for purchasing a Hutchinson Portable Grain Belt Conveyor. This equipment will allow safe and efficient operation when you read and follow all of the instructions contained in this manual. With proper care, your conveyor will provide you with many years of trouble-free operation.

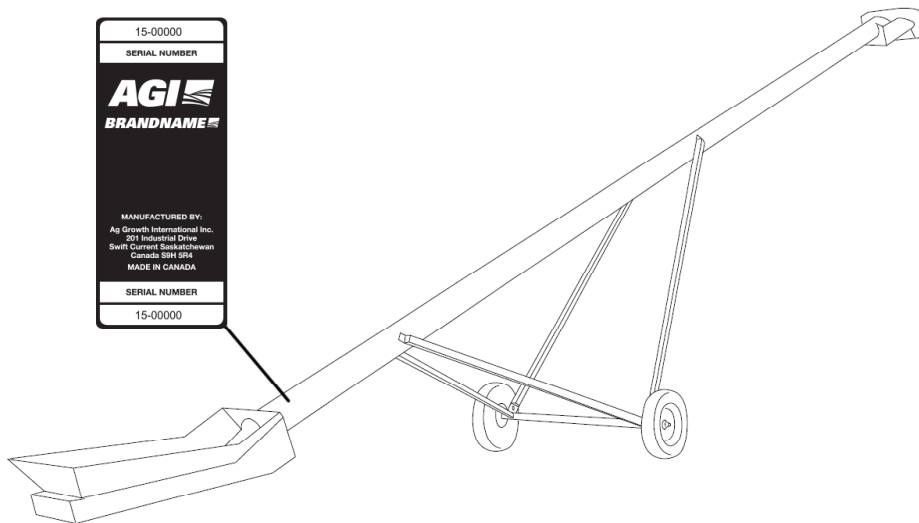
Keep this manual handy for frequent reference and to review with new personnel. A sign-off form is provided on the inside front cover for your convenience. If any information in this manual is not understood or if you need additional information, please contact your local distributor or dealer for assistance.

This manual should be regarded as part of the equipment. Suppliers of both new and second-hand equipment are advised to retain documentary evidence that this manual was provided with the equipment.

## 1.1. Serial Number Location

Always give your dealer the serial number on your conveyor (shown below) when ordering parts or requesting service or other information. Please record this information in the table below for easy reference.

<b>Model Number</b>	
<b>Serial Number</b>	
<b>Date Received</b>	



## 1.2. Intended Use

The conveyor is designed solely for use in the intended agricultural use as listed below. Use in any other way is considered as contrary to the intended use. Compliance with and strict adherence to the conditions of operation and maintenance as specified by the manufacturer, also constitute essential elements of the intended use.

The conveyor should be operated, maintained, serviced, and repaired only by persons who are familiar with its particular characteristics and who are acquainted with the relevant safety procedures.



Accident prevention regulations and all other generally recognized regulations on occupational health and safety must be observed at all times.

Any modifications made to the conveyor may relieve the manufacturer of liability for any resulting damage or injury.

**Intended use for the conveyor:**

- Handling grain, pulse crops, treated seeds, or other similar materials.
- Handling fertilizer when strict operation and cleanout procedures are followed as noted in Operation section.

Use in any other way is considered as contrary to the intended use and is not covered by the warranty.

### ***1.2.1 Misuse***

Do not use the conveyor for/with:

- transferring material other than dry, free-flowing food-grains.
- conveying canola, or any other oilseeds
- lifting or using as a hoist or crane.

# 2. Safety

## 2.1. Safety Alert Symbol and Signal Words

---



This safety alert symbol indicates important safety messages in this manual. When you see this symbol, be alert to the possibility of injury or death, carefully read the message that follows, and inform others.

**Signal Words:** Note the use of the signal words **DANGER**, **WARNING**, **CAUTION**, and **NOTICE** with the safety messages. The appropriate signal word for each message has been selected using the definitions below as a guideline.



**DANGER** Indicates an imminently hazardous situation that, if not avoided, will result in serious injury or death.



**WARNING** Indicates a hazardous situation that, if not avoided, could result in serious injury or death.



**CAUTION** Indicates a hazardous situation that, if not avoided, may result in minor or moderate injury.



**NOTICE** Indicates a potentially hazardous situation that, if not avoided, may result in property damage.

## 2.2. General Product Safety

---

**YOU** are responsible for the **SAFE** use and maintenance of your conveyor. **YOU** must ensure that you and anyone else who is going to work around the conveyor understands all procedures and related **SAFETY** information contained in this manual.

Remember, **YOU** are the key to safety. Good safety practices not only protect you, but also the people around you. Make these practices a working part of your safety program. All accidents can be avoided.

- It is the conveyor owner, operator, and maintenance personnel's responsibility to read and understand **ALL** safety instructions, safety decals, and manuals and follow them when assembling, operating, or maintaining the equipment.
- Owners must give instructions and review the information initially and annually with all personnel before allowing them to operate the conveyor. Untrained users/operators expose themselves and bystanders to possible serious injury or death.
- The conveyor is not intended to be used by children.
- Use the conveyor for its intended purposes only.
- Do not modify the conveyor in any way without written permission from the manufacturer. Unauthorized modification may impair the function and/or safety, and could affect the life of the conveyor. Any unauthorized modification of the conveyor will void the warranty.



## 2.3. Overhead Power Lines

---

### DANGER

- When operating or moving, keep conveyor away from overhead power lines and devices.
- The conveyor is not insulated.
- Electrocutation can occur without direct contact.



## 2.4. Moving Conveyor Belt Safety

---

### WARNING

- DO NOT step on or touch moving conveyor belt.
- Shut off and lock out power to adjust, service, or clean.

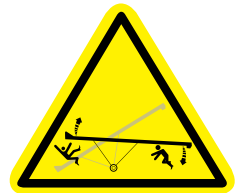


## 2.5. Upending

---

### WARNING

- Anchor intake end and/or support discharge end to prevent upending.
- Intake end must always have downward weight. Do not release until attached to tow bar or resting on ground.
- Do not raise intake end above tow bar height.
- Empty the conveyor and fully lower before moving.



## 2.6. Rotating Parts Safety

---

### WARNING

- Keep body, hair, and clothing away from rotating pulleys, belts, chains, and sprockets.
- Do not operate with any guard removed or modified. Keep guards in good working order.
- Shut off and remove key or lock out power source before inspecting or servicing machine.

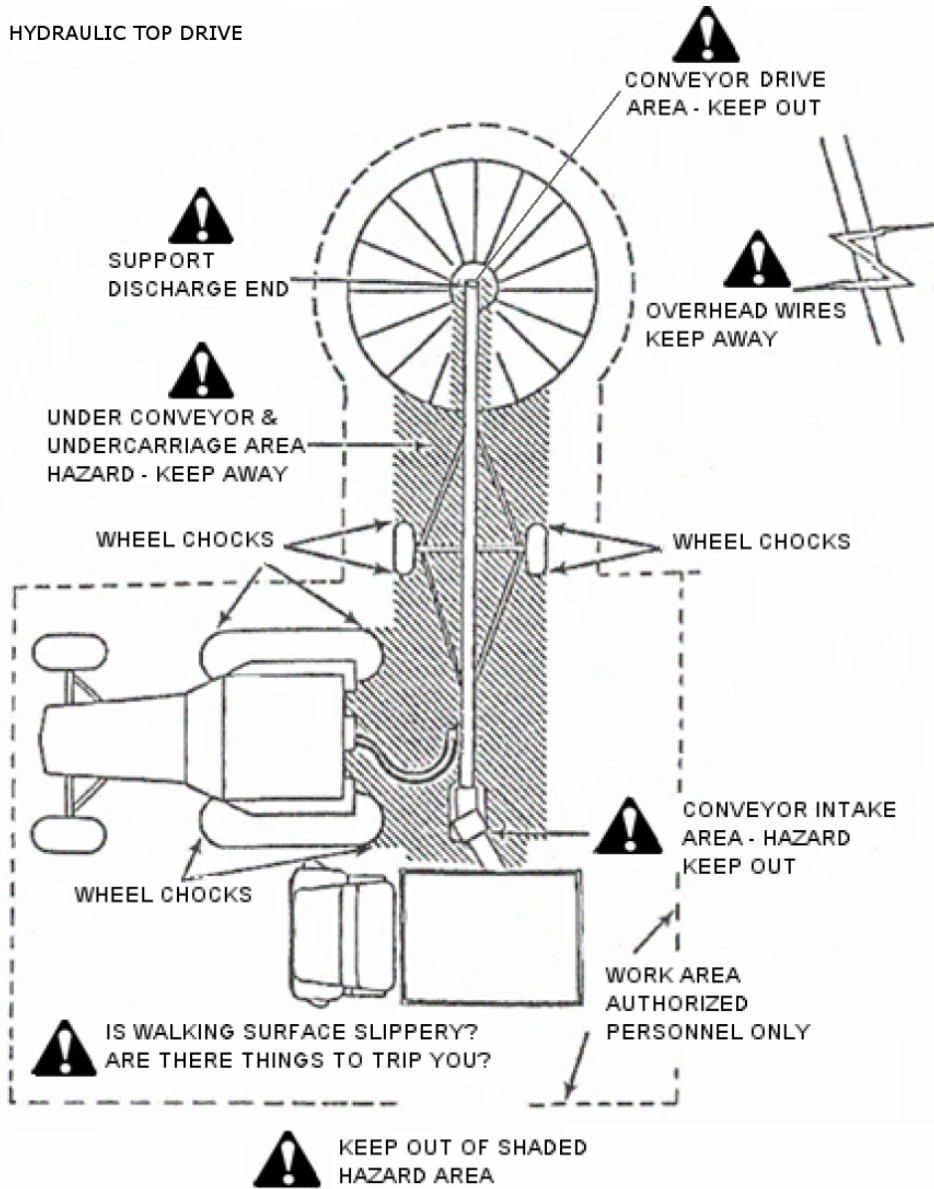


## 2.7. Work Area Safety

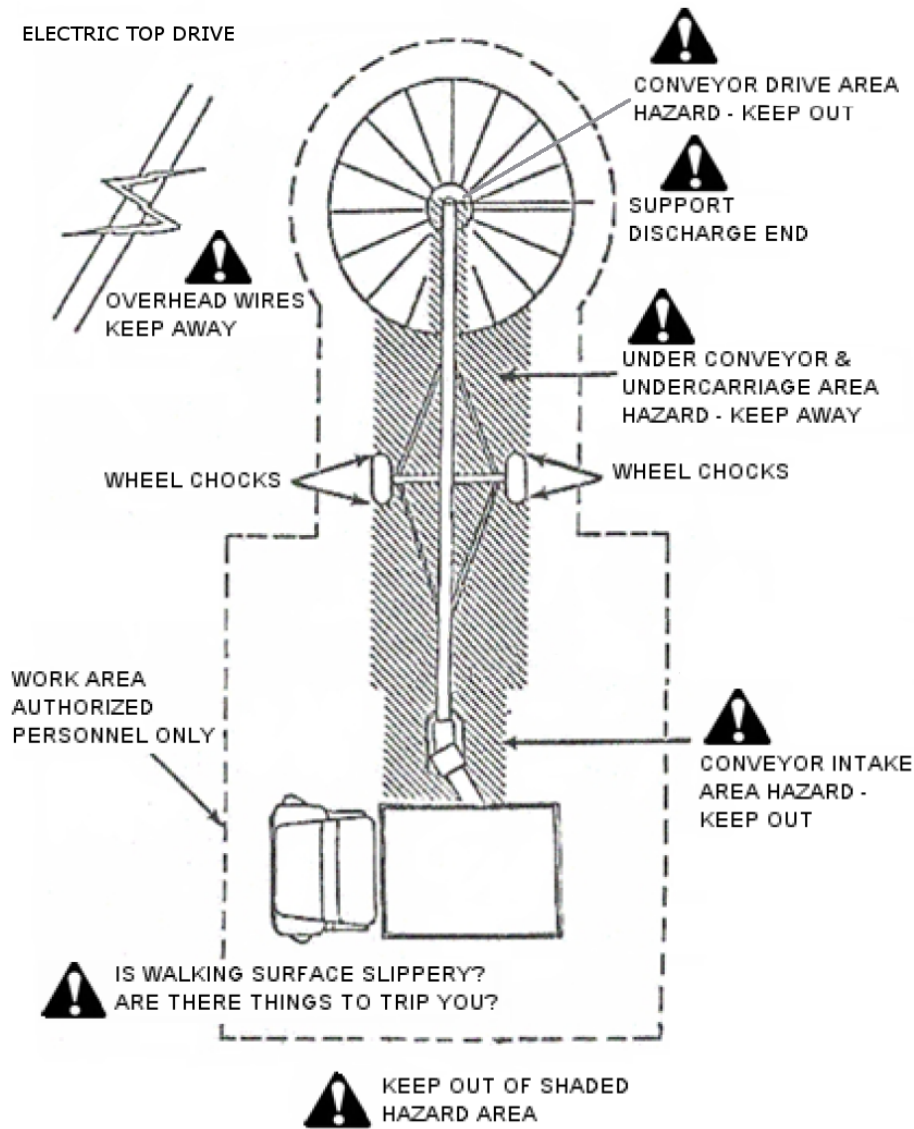
---

- Have another trained person nearby who can shut down the conveyor in case of accident.
- The work area should be kept clear of bystanders.
- Keep the work area clean and free of debris.

Figure 1. Conveyor Work Area (Hydraulic Drive)



**Figure 2. Conveyor Work Area (Electric Drive)**



## 2.8. Guards Safety

- ⚠ WARNING**
- Keep guards in place and do not operate unless all guards are in place.
  - Do not walk on, step on, or damage guards.
  - Lock out power before removing a guard.
  - Ensure all guards are replaced after performing maintenance.

## 2.9. Raising and Lowering the Conveyor

---

- ⚠ WARNING**
- Before raising/lowering/moving/adjusting the conveyor, make sure the area around the conveyor is clear of obstructions and/or untrained personnel. Never allow anyone to stand on or beneath the conveyor when it is being placed.
  - Lower the conveyor to its lowest position when not in use.
  - Empty the conveyor before raising or lowering.
  - Do not get on or beneath the conveyor when raising or lowering.
  - Raise and lower conveyor on reasonably level ground only.
  - Never attempt to increase height of the tube by positioning wheels on lumber, blocks, or by any other means. To do so will result in damage to conveyor and/or serious injury.
  - Do not raise the conveyor in high winds.

## 2.10. Hand Winch Safety

---

- ⚠ WARNING** When Equipped:
- Inspect lift cable before using. Replace if frayed or damaged. Make sure lift cable is seated properly in cable sheaves and cable clamps are secure.
  - Tighten brake lock by turning winch handle clockwise at least two clicks after lowering the conveyor.
  - Lower the conveyor fully before towing, then rotate winch handle until cable has light tension.
  - Do not lubricate winch brake discs.

## 2.11. Conveyor Stability

---

- ⚠ WARNING**
- Transport and place equipment on reasonably level ground when raising, lowering, positioning, or operating.
  - Chock wheels and anchor intake end after placement.



## 2.12. Towing the Conveyor

---

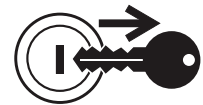
### **WARNING**

- Check with local authorities regarding transport on public roads. Obey all applicable laws and regulations.
- Always travel at a safe speed, never exceeding 20 mph (32 km/h).
- Reduce speed on rough surfaces.
- Do not transport on slopes greater than 20°.
- Use caution when turning corners or meeting traffic.
- Make sure the SMV (slow moving vehicle) emblem and all the lights and reflectors that are required by local authorities are in place, are clean, and can be seen by all over-taking and oncoming traffic.
- Always use hazard-warning flashers on tractor/towing vehicle when transporting unless prohibited by law.
- Do not allow riders on the conveyor or towing vehicle during transport.
- Attach to towing vehicle with an appropriate pin and retainer. Always attach safety chain(s).
- Place the conveyor in the transport position before moving on roads.

## 2.13. Drives and Lockout Safety

---

Inspect the power source(s) before using and know how to shut down in an emergency. Whenever you service or adjust your equipment, make sure you shut down the power source and unplug or remove the key (as applicable) to prevent inadvertent start-up and hazardous energy release. Know the procedure(s) that applies to your equipment from the following power source(s). Ensure that all personnel are clear before turning on power to equipment.



### 2.13.1 Electric Motor Safety

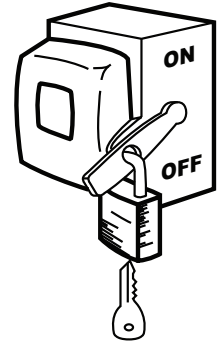
#### **WARNING** Power Source

- Electric motors and controls shall be installed and serviced by a qualified electrician and must meet all local codes and standards.
- A magnetic starter should be used to protect your motor.
- You must have a manual reset button.
- Reset and motor starting controls must be located so that the operator has full view of the entire operation.
- Locate main power disconnect switch within reach from ground level to permit ready access in case of an emergency.
- Motor must be properly grounded.
- Guards must be in place and secure.
- Ensure electrical wiring and cords remain in good condition; replace if necessary.
- Use a totally enclosed electric motor if operating in extremely dusty conditions.

#### **Lockout**

- The main power disconnect switch should be in the locked position during shutdown or whenever maintenance is performed.
- If reset is required, disconnect all power **before** resetting motor.

#### **SERVICE DISCONNECT**



### 2.13.2 Hydraulic Power Safety

#### **WARNING** Power Source

- Refer to the rules and regulations applicable to the power source operating your hydraulic drive.
- Do not connect or disconnect hydraulic lines while system is under pressure.
- Keep all hydraulic lines away from moving parts and pinch points.
- Escaping hydraulic fluid under pressure will cause serious injury if it penetrates the skin surface (serious infection or toxic reaction can develop). See a doctor immediately if injured.
- Use metal or wood as a backstop when searching for hydraulic leaks and wear proper hand and eye protection.
- Check all hydraulic components are tight and in good condition. Replace any worn, cut, abraded, flattened, or crimped hoses.
- Clean the connections before connecting to equipment.
- Do not attempt any makeshift repairs to the hydraulic fittings or hoses with tape, clamps, or adhesive. The hydraulic system operates under extremely high pressure; such repairs will fail suddenly and create a hazardous and unsafe condition.

#### **Lockout**

- Always place all hydraulic controls in neutral and relieve system pressure before disconnecting or working on hydraulic system.



## 2.14. Tire Safety

**WARNING** Failure to follow proper procedures when mounting a tire on a wheel or rim can produce an explosion that may result in serious injury or death.



- DO NOT attempt to mount a tire unless you have the proper equipment and experience to do the job.
- Have a qualified tire dealer or repair service perform required tire maintenance.
- When replacing worn tires, make sure they meet the original tire specifications. Never undersize the replacement tire.
- DO NOT weld to the tire rim with the tire mounted on the rim. This action may cause an explosion which could result in serious injury or death.
- Inflate tires to the manufacturer's recommended pressure.
- Tires should not be operated at speeds higher than their rated speed.
- Keep wheel lug nuts tightened to manufacturer's recommendations.
- Never reinflate a tire that has been run flat or seriously under-inflated without removing the tire from the wheel. Have the tire and wheel closely inspected for damage before remounting.

## 2.15. Personal Protective Equipment

The following Personal Protective Equipment (PPE) should be worn when operating or maintaining the equipment.

### Safety Glasses

- Wear safety glasses at all times to protect eyes from debris.



### Coveralls

- Wear coveralls to protect skin.



### Hard Hat

- Wear a hard hat to help protect your head.



### Steel-Toe Boots

- Wear steel-toe boots to protect feet from falling debris.



### Work Gloves

- Wear work gloves to protect your hands from sharp and rough edges.



### Dust Mask

- Wear a dust mask to prevent breathing potentially harmful dust.



## 2.16. Safety Equipment

---

The following safety equipment should be kept on site:

### Fire Extinguisher

- Provide a fire extinguisher for use in case of an accident. Store in a highly visible and accessible place.



### First-Aid Kit

- Have a properly-stocked first-aid kit available for use should the need arise, and know how to use it.



## 2.17. Safety Decals

---

- Keep safety decals clean and legible at all times.
- Replace safety decals that are missing or have become illegible. See decal location figures that follow.
- Replaced parts must display the same decal(s) as the original part.
- Replacement safety decals are available **free of charge** from your distributor, dealer, or factory as applicable.

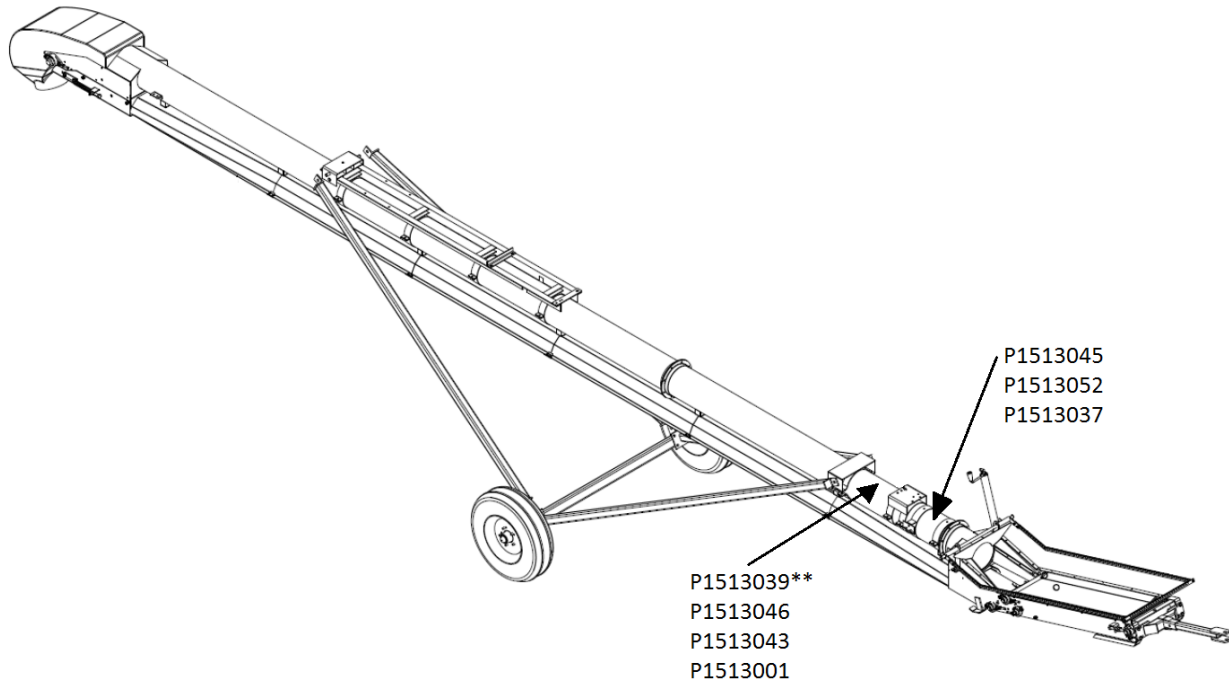
### 2.17.1 Decal Installation/Replacement

1. Decal area must be clean and dry, with a temperature above 50°F (10°C).
2. Decide on the exact position before you remove the backing paper.
3. Align the decal over the specified area and carefully press the small portion with the exposed sticky backing in place.
4. Slowly peel back the remaining paper and carefully smooth the remaining portion of the decal in place.
5. Small air pockets can be pierced with a pin and smoothed out using the sign backing paper.

### 2.17.2 Safety Decal Locations and Details

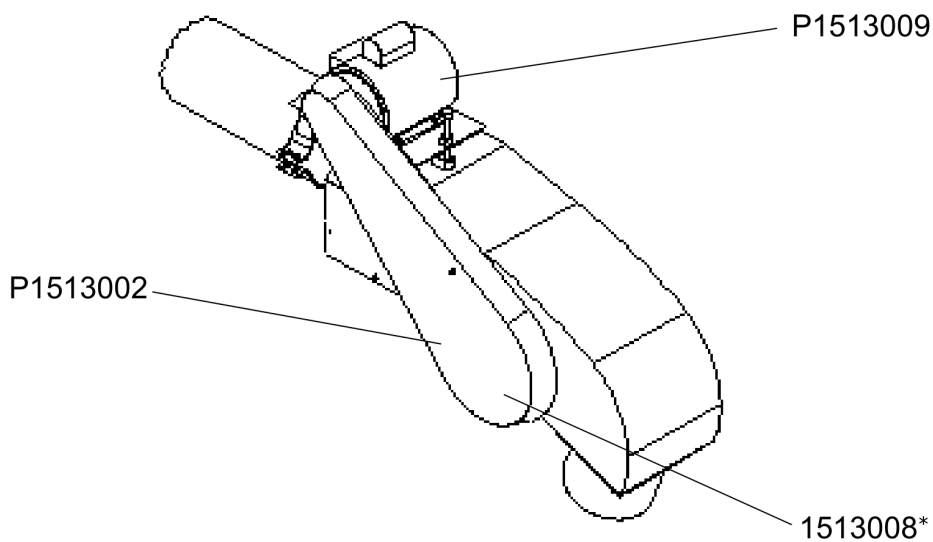
Replicas of the safety decals that are attached to the conveyor and their messages are shown in the figure(s) that follow. Safe operation and use of the conveyor requires that you familiarize yourself with the various safety decals and the areas or particular functions that the decals apply to, as well as the safety precautions that must be taken to avoid serious injury, death, or damage.

**Figure 3. Conveyor Safety Decal Locations**



\*\* if equipped with hand winch

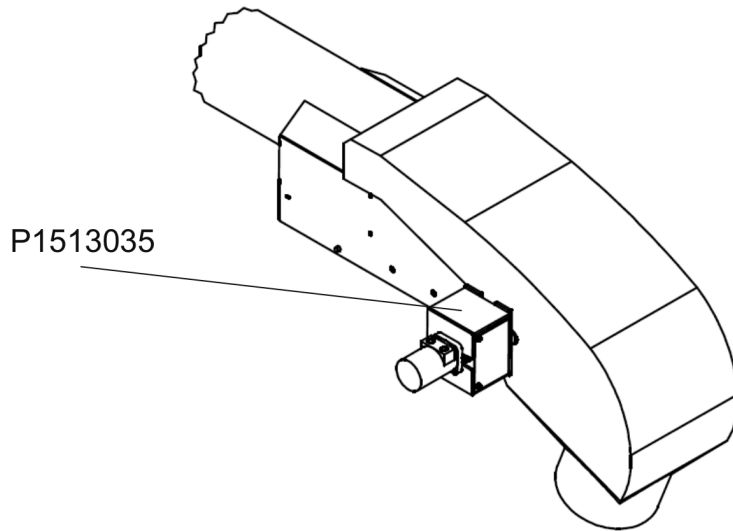
**Figure 4. Electric Top Drive Safety Decal Locations**





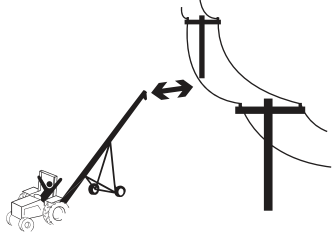



**Figure 4 Electric Top Drive Safety Decal Locations (continued)**

\* behind guard

**Figure 5. Hydraulic Top Drive Safety Decal Locations**



**Table 1. Safety Decals**




Part Number	Description
P1513046	<div style="border: 1px solid black; padding: 10px;"> <div style="background-color: red; color: white; text-align: center; padding: 5px;">  <b>DANGER</b> </div> <div style="display: flex; justify-content: space-around; align-items: center; margin-top: 10px;">   </div> <div style="text-align: center; margin-top: 10px;"> <p><b>ELECTROCUTION HAZARD</b></p> <p>To prevent death or serious injury:</p> <ul style="list-style-type: none"> <li>• When operating or moving, keep equipment away from overhead power lines and devices.</li> <li>• Fully lower equipment before moving.</li> </ul> <p>This equipment is not insulated. Electrocution can occur without direct contact.</p> </div> </div>
P1513045	<div style="border: 1px solid black; padding: 10px;"> <div style="background-color: orange; color: black; text-align: center; padding: 5px;">  <b>WARNING</b> </div> <div style="display: flex; justify-content: space-around; align-items: center; margin-top: 10px;">   </div> <div style="text-align: center; margin-top: 10px;"> <p><b>OPEN BELT CONVEYOR</b></p> <p>To prevent death or serious injury:</p> <ul style="list-style-type: none"> <li>• DO NOT step on or touch moving conveyor belt.</li> <li>• Shut off and lock out power to adjust, service, or clean.</li> </ul> </div> </div>



**Table 1 Safety Decals (continued)**

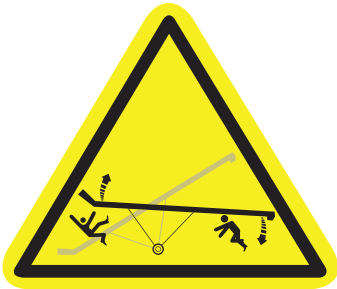
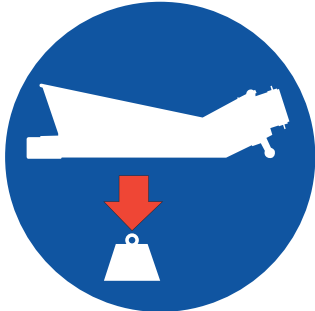

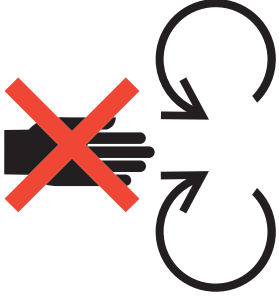
Part Number	Description
P1513037	<div style="border: 2px solid black; padding: 10px;"> <div style="background-color: #FFA500; padding: 5px; text-align: center;">  <span style="font-size: 24pt; font-weight: bold; color: black;">WARNING</span> </div> <div style="text-align: center; padding: 10px 0;"> <p><b>TRANSPORT HAZARD</b></p> <p>To prevent serious injury or death:</p> <ul style="list-style-type: none"> <li>• Securely attach equipment to vehicle with correct pin and safety chains.</li> <li>• Use a tow vehicle to move equipment.</li> </ul> </div> </div>

**Table 1 Safety Decals (continued)**
























Part Number	Description
P1513001	<div style="border: 2px solid black; padding: 10px;"> <div style="background-color: #f4a460; text-align: center; padding: 5px;">  <span style="font-size: 24pt; font-weight: bold; color: white;">WARNING</span> </div> <div style="display: flex; justify-content: space-around; align-items: center; padding: 10px 0;"> <div style="text-align: center;">  </div> <div style="text-align: center;">  </div> </div> <p style="margin-top: 10px;">To prevent serious injury or death:</p> <ul style="list-style-type: none"> <li>• Read and understand the manual before assembling, operating, or maintaining the equipment.</li> <li>• Only trained personnel may assemble, operate, or maintain the equipment.</li> <li>• Children and untrained personnel must be kept outside of the work area.</li> <li>• Do not modify the equipment. Keep in good working order.</li> <li>• If the manual, guards, or decals are missing or damaged, contact factory or dealer for replacements.</li> <li>• Lock out power before performing maintenance.</li> <li>• To prevent equipment collapse, support equipment tube while disassembling certain components.</li> <li>• Electric motors must be grounded. Disconnect power before resetting overloads.</li> </ul> </div>



**Table 1 Safety Decals (continued)**


Part Number	Description
P1513043	<div style="border: 1px solid black; padding: 5px;"> <div style="background-color: #f4a460; padding: 2px; text-align: center; font-weight: bold;"> <b>WARNING</b> </div> <div style="display: flex; justify-content: space-around; align-items: center; height: 150px;">   </div> <div style="text-align: center; font-weight: bold; margin-top: 5px;"> <b>UPENDING HAZARD</b> </div> <p>To prevent death or serious injury:</p> <ul style="list-style-type: none"> <li>Anchor intake end and/or support discharge end to prevent upending.</li> <li>Intake end must always have downward weight. Do not release until attached to tow bar or resting on ground.</li> <li>Do not raise intake end above tow bar height.</li> <li>Empty conveyor and fully lower before moving.</li> </ul> </div>
P1513002	<div style="border: 1px solid black; padding: 5px;"> <div style="background-color: #f4a460; padding: 2px; text-align: center; font-weight: bold;"> <b>WARNING</b> </div> <div style="display: flex; justify-content: space-around; align-items: center; height: 150px;">   </div> <div style="text-align: center; font-weight: bold; margin-top: 5px;"> <b>ENTANGLEMENT HAZARD</b> </div> <p>To prevent serious injury or death:</p> <ul style="list-style-type: none"> <li>Keep body, hair, and clothing away from rotating pulleys, belts, chains, and sprockets.</li> <li>Do not operate with any guard removed or modified. Keep guards in good working order.</li> <li>Shut off and remove key or lock out power source before inspecting or servicing machine.</li> </ul> </div>

**Table 1 Safety Decals (continued)**

Part Number	Description				
P1513008	<div style="border: 1px solid black; padding: 5px;"> <div style="background-color: #f4a460; padding: 5px; text-align: center;">  <b>WARNING</b> </div> <table border="1" style="width: 100%; border-collapse: collapse;"> <tr> <td style="width: 25%; text-align: center; vertical-align: middle;">  </td> <td style="padding: 5px;"> <p><b>MISSING GUARD HAZARD</b></p> <p>To prevent serious injury or death, shut off power and reattach guard before operating machine.</p> </td> </tr> <tr> <td style="text-align: center; vertical-align: middle;">  </td> <td></td> </tr> </table> </div>		<p><b>MISSING GUARD HAZARD</b></p> <p>To prevent serious injury or death, shut off power and reattach guard before operating machine.</p>		
	<p><b>MISSING GUARD HAZARD</b></p> <p>To prevent serious injury or death, shut off power and reattach guard before operating machine.</p>				
					
P1513009	<table border="1" style="width: 100%; border-collapse: collapse;"> <tr> <td style="width: 25%; text-align: center; vertical-align: middle;">  </td> <td style="padding: 5px;"> <div style="background-color: #f4a460; padding: 5px; text-align: center;">  <b>WARNING</b> </div> <p><b>ELECTROCUTION HAZARD</b></p> <p>To prevent serious injury or death:</p> <ul style="list-style-type: none"> <li>• Only qualified personnel should service electrical components.</li> <li>• Disconnect and lockout power before inspecting or servicing unit.</li> <li>• Keep electrical components in good repair.</li> </ul> </td> </tr> <tr> <td style="text-align: center; vertical-align: middle;">  </td> <td></td> </tr> </table>		<div style="background-color: #f4a460; padding: 5px; text-align: center;">  <b>WARNING</b> </div> <p><b>ELECTROCUTION HAZARD</b></p> <p>To prevent serious injury or death:</p> <ul style="list-style-type: none"> <li>• Only qualified personnel should service electrical components.</li> <li>• Disconnect and lockout power before inspecting or servicing unit.</li> <li>• Keep electrical components in good repair.</li> </ul>		
	<div style="background-color: #f4a460; padding: 5px; text-align: center;">  <b>WARNING</b> </div> <p><b>ELECTROCUTION HAZARD</b></p> <p>To prevent serious injury or death:</p> <ul style="list-style-type: none"> <li>• Only qualified personnel should service electrical components.</li> <li>• Disconnect and lockout power before inspecting or servicing unit.</li> <li>• Keep electrical components in good repair.</li> </ul>				
					
P1513035	<div style="border: 1px solid black; padding: 5px;"> <div style="background-color: #f4a460; padding: 5px; text-align: center;">  <b>WARNING</b> </div> <table border="1" style="width: 100%; border-collapse: collapse;"> <tr> <td style="width: 50%; text-align: center; vertical-align: middle;">  </td> <td style="width: 50%; text-align: center; vertical-align: middle;">  </td> </tr> </table> <div style="padding: 5px;"> <p><b>HIGH PRESSURE FLUID HAZARD</b></p> <p>Hydraulic fluid can cause serious injury if it penetrates the skin. If it does, see a doctor immediately.</p> <ul style="list-style-type: none"> <li>• Relieve system pressure before repairing, adjusting or disconnecting.</li> <li>• Wear proper hand and eye protection when searching for leaks. Use wood or cardboard instead of hands.</li> </ul> </div> </div>				
					



**Table 1 Safety Decals (continued)**

Part Number	Description
P1513039	<div style="border: 2px solid black; padding: 10px;"> <div style="background-color: yellow; text-align: center; padding: 5px;">  <span style="font-size: 24pt; font-weight: bold; margin-left: 10px;">CAUTION</span> </div> <p>For proper raising and lowering of equipment:</p> <ul style="list-style-type: none"> <li>• After lowering equipment, always tighten brake lock by turning winch handle clockwise at least two clicks.</li> <li>• Rotate winch handle until cable has light tension, when in towing position.</li> <li>• Do not lubricate winch brake discs.</li> <li>• Inspect lift cable periodically; replace if damaged.</li> <li>• Inspect cable clamps periodically; tighten if necessary.</li> </ul> </div>
P1513052	<div style="border: 2px solid black; padding: 10px;"> <div style="background-color: blue; color: white; text-align: center; padding: 5px; font-weight: bold; font-size: 24pt;">NOTICE</div> <p>To prevent damage, wheels must be free to move when raising or lowering equipment.</p> <p>When equipment is positioned, chock all wheels.</p> </div>

# 3. Features

This section covers the main features of the conveyor.

Figure 6. Typical Top-Drive Field Loader Components

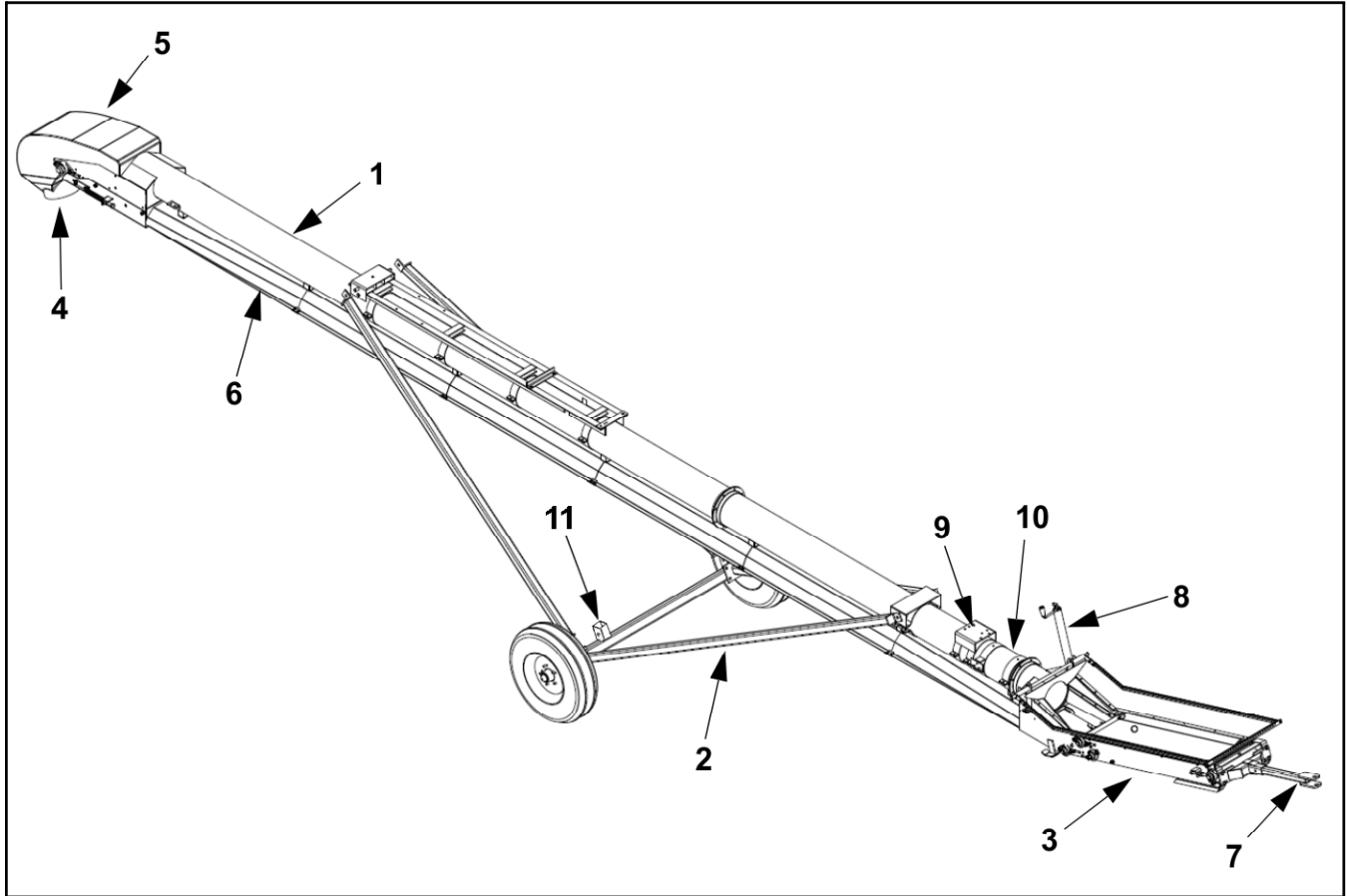


Table 2. Typical Top-Drive Field Loader Components

ITEM	DESCRIPTION
1	Tube
2	A-Frame
3	Hopper
4	Spout Assembly
5	Hood
6	Belt Return and Weather Guard

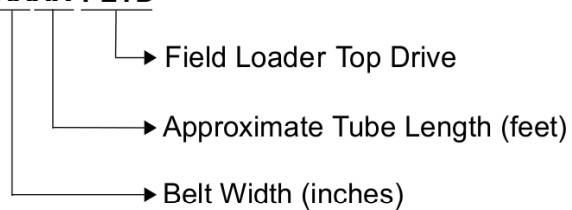
ITEM	DESCRIPTION
7	Hitch
8	Jack
9	Winch
10	Collapsible Hopper Control
11	Hitch Tongue Holder



### 3.1. Model Number

---

**XXXX FLTD**



# 4. Transport



Before continuing, ensure you have completely read and understood this manual's Safety section, in addition to the safety information in the section(s) below.

## 4.1. Transport Safety

---

### WARNING

- Check with local authorities regarding transport on public roads. Obey all applicable laws and regulations.
- Always travel at a safe speed, never exceeding 20 mph (32 km/h). Reduce speed on rough surfaces. Use caution when turning corners or meeting traffic.
- Yield to other drivers and allow faster traffic to pass.
- Make sure the SMV (slow moving vehicle) emblem and all the lights and reflectors that are required by local authorities are in place, are clean, and can be seen by all over-taking and oncoming traffic. Always use hazard-warning flashers on tractor/towing vehicle when transporting unless prohibited by law.
- Do not transport during times of limited visibility such as fog, snow, or heavy rain. Take extra precautions at night and at dusk.
- Keep others away from the transport vehicle and conveyor.
- Do not allow riders on the conveyor or towing vehicle during transport.
- Stay away from overhead obstructions and power lines when operating and transporting. Electrocutation can occur without direct contact.
- Fully lower the conveyor before transporting, and only raise when next to storage facility.
- Attach to a proper towing vehicle with a pin and retainer. Always attach safety chain(s).
- Do not raise the intake end above drawbar, upending may occur.
- Empty conveyor of all grain before transporting. Transporting a full conveyor will place excessive loads on the tube, frame, axle, hitch, and tow vehicle.
- Do not transport on slopes greater than 20°.
- Do not transport with an under-inflated tire(s).
- If the conveyor wheels are partially or fully buried in snow or grain, failure to clear area around the wheels before transporting may cause damage to the conveyor or result in serious injury.

## 4.2. Transport Preparation

---

1. It is not recommended that the conveyor be transported faster than 20 mph (32 km/h). [Table 3](#) references the acceptable transport speed as per the ratio of tractor weight versus conveyor weight. See Specifications for conveyor weights.

### WARNING

A weight imbalance between the and the towing vehicle could result in a collision from reduced stability, handling, and braking ability.

2. Ensure the conveyor will clear any overhead obstructions or electrical wires prior to transporting. Refer to Specifications for the transport height of your conveyor.



- Longer conveyors have a large turning radius. Allow ample room for turning as the discharge end may swing dramatically. Allow all oncoming traffic to pass before turning right or left.

**WARNING**

A collision with an oncoming vehicle could occur if the conveyor discharge swings into the opposing lane.

**Table 3. Speed versus Weight Ratio**

Road Speed	Weight or fully equipped or loaded implement(s) relative to weight of towing machine
Up to 32 km/h (20 mph)	1 to 1, or less
Up to 16 km/h (10 mph)	2 to 1, or less
Do not tow if	More than 2 to 1

### 4.3. Connect the Conveyor to the Towing Vehicle

This section provides an overview of how to connect the conveyor to the towing vehicle. For specific information on the components, refer to the applicable section.

Follow all safety precautions when transporting the conveyor and use a proper towing vehicle.

- Fully lower the conveyor, there should be slight tension on the lift cable.
- Connect the conveyor to the two vehicle with a hitch pin. Use a hitch pin that will not allow the conveyor to separate from the towing vehicle.
- Connect the safety chain securely, forming a cradle to prevent the conveyor from digging into the road surface (should a breakaway occur). Do not use the safety chain if one or more links or end fittings are stretched, broken, damaged, or deformed.

**Important**

The safety chain should have a load rating at least as high as the conveyor weight.

- Use caution when transporting the conveyor over rolling terrain. In severe dips, the intake end may contact the ground.

Refer to [Section 9. – Specifications on page 56](#) for conveyor weight and hitch pin information.

# 5. Placement



Before continuing, ensure you have completely read and understood this manual's Safety section, in addition to the safety information in the section(s) below.

## 5.1. Placement Safety

---

### **WARNING**

- The conveyor is not insulated, keep away from overhead power lines. Electrocution can occur without direct contact.
- Anchor intake end before using.
- Place the conveyor on reasonably level ground before operating. The conveyor could topple if ground is too uneven.
- Chock the conveyor wheels after placement.
- Empty the conveyor before raising, lowering, or positioning.
- Check that wheels are free to move before raising or lowering the conveyor.
- Never attempt to increase height of the conveyor by positioning wheels on lumber, blocks, or by any other means.
- Do not permit anyone to stand beneath the conveyor when raising or lowering.
- Move the conveyor into position slowly. Do not unhitch and attempt to move by hand.
- Do not leave tube in raised position when not in use.

## 5.2. Positioning the Conveyor

---

To position the conveyor using a tractor:

### Filling Bins

1. Back the conveyor up to the bin while it is in its lowered configuration.
2. Set the park brake on the tractor before dismounting.
3. Raise the conveyor so it clears the bin.
4. Slowly back the conveyor up until the outlet is over the opening in the bin.
5. Unhook the conveyor from the tractor and lower the intake end to the ground.



### **WARNING**

Upending hazard, do not hook or unhook hitch unless weight is down.

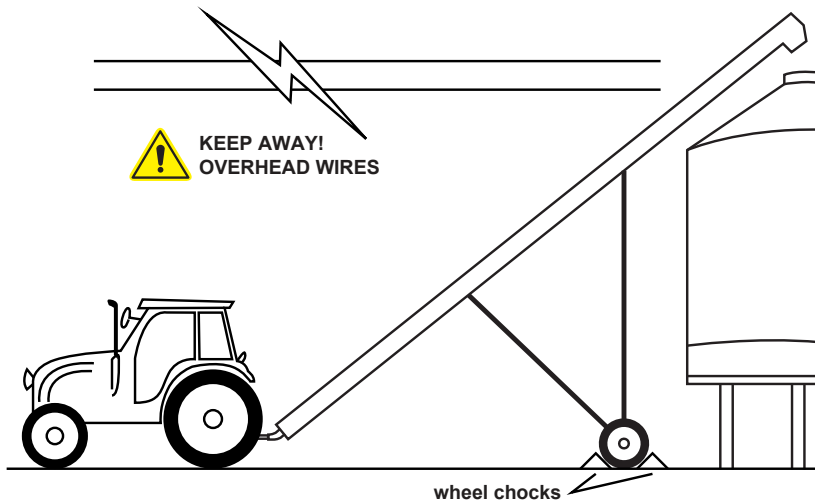
6. Slowly lower the conveyor spout to the bin.

### **NOTICE**

Do not rest the spout or hood on the bin. This may cause hood or belt damage.

7. Remove the hitch from the conveyor to prevent interfering with other equipment.
8. Place chocks in the front and back of each wheel and anchor the intake end.



**Figure 7. Typical Grain Conveyor Placement for Filling Bins****Under Hopper Bottom Bins**

1. Center the conveyor between the hopper bin's vertical legs.
2. Collapse the cloth hopper until the conveyor is fully positioned under the bin.
3. Move the conveyor into place. Do not allow the conveyor tube or components to contact the bin.
4. Raise the conveyor to the desired height.
5. Make sure that gravel is not jammed against the belt under the hopper.
6. Place chocks in the front and back of each wheel and anchor the intake end.

**5.3. Hand Winch Operation**

➡ When equipped with a Hand Winch:

**Before using the hand winch, ensure that:**

- the cable anchor on the winch drum is tight.
- all cable clamps are secure.
- the lift cable is seated in cable pulley.
- the cable is in good condition, if damaged, replace it immediately.
- there is a minimum of 3 cable wraps on the winch drum when the conveyor fully lowered.

**To operate:**

1. Turn the winch handle to raise and lower the conveyor. The winch must make a clicking sound when raising the conveyor. If clicking sound stops, retain grip on handle, lower the conveyor fully and repair winch.
2. When lowering, if the cable becomes slack before conveyor is in full down position, this indicates that the track shoe is stuck. To correct the problem, reverse the winch and raise the conveyor until the cable is taut and the track slides normally. Do not lubricate the winch brake discs.

3. After lowering the conveyor, always tighten the brake lock by turning the winch handle clockwise at least two clicks.
4. After lowering, rotate the winch handle until cable has light tension.

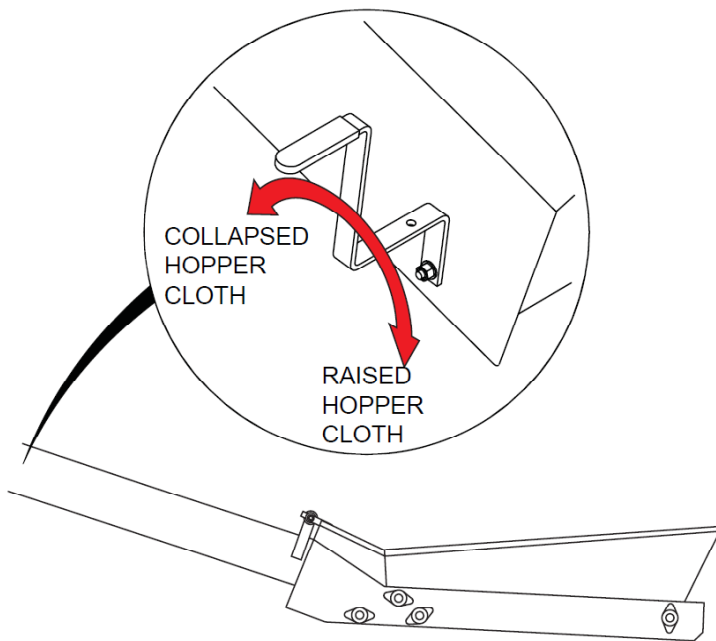
## 5.4. Collapsible Hopper Cloth Control

---

The conveyor is designed with a collapsible hopper cloth to allow it to go under low discharge units.

Move the control handle toward the hopper or intake to raise the hopper cloth, and move the handle toward the outlet or spout end to collapse the hopper cloth, see [Figure 8 on page 31](#).

**Figure 8. Collapsible Hopper Handle**



## 5.5. Conveyor Operating Angles

---

The conveyor lift can set the tube angle up to 30° when operating. Because the belt does not have roll back barriers, the material will roll back if the angle is too steep. Do not position the conveyor at an angle steeper than the grain will roll back (angle of repose) of the material to be moved.

### Note

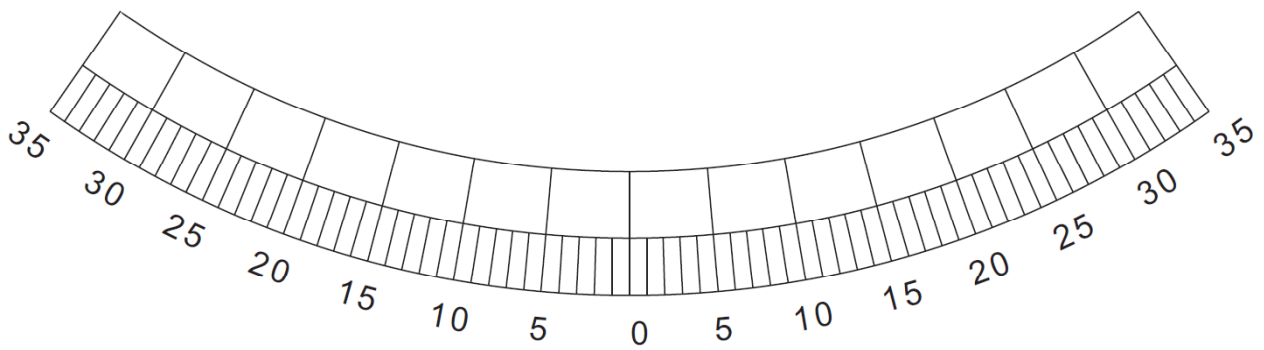
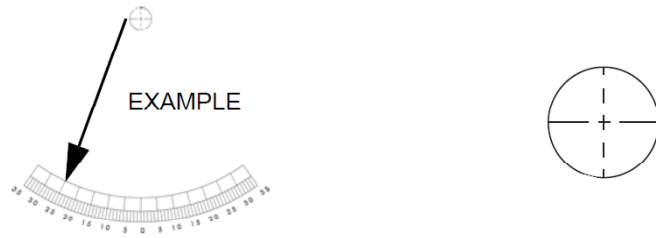
The lower the angle, the greater the capacity of the conveyor.

The following table indicates the maximum angle a conveyor can move grain.

To roughly determine conveyor angle, use angle guide on right. Stand the manual (vertically) on conveyor tube and hold a string with a weight attached to end against the top of this page. Weighted end of string will fall between degree lines, and from this the approximate angle of the conveyor can be determined.



**Figure 9. Conveyor Operating Angles**



**Table 4. Maximum Conveying Angles for Grains**

Grain	Maximum Conveyor Operating Angle (degrees)
Flax	24
Lentils	29
Mustard	26
Oats	28
Peas	30
Rice	36

**Table 4 Maximum Conveying Angles for Grains (continued)**

<b>Grain</b>	<b>Maximum Conveyor Operating Angle (degrees)</b>
Rye	25
Soybeans	28
Sunflower	22
Triticale	23
Wheat	26
Alfalfa Pellets	34
Barley	25
Canary Seed	26
Chickpeas	30
Corn	26
Shelled Corn (dry)	25
Shelled Corn (wet)	28
Cotton Seed	30-45
Durum	25



# 6. Operation



Before continuing, ensure you have completely read and understood this manual's Safety section, in addition to the safety information in the section(s) below.

## 6.1. Operation Safety

---



### WARNING

- Keep away from rotating and moving parts, including the conveyor belt, drive components, shafts, and bearings.
- Do not enter the grain bin while the conveyor is operating.
- Always operate with guards, covers, and shields in place.
- Have another trained person nearby who can shut down the equipment in case of accident.
- Keep the work area clear of bystanders.
- Keep the work area clean and free of debris.
- Ensure maintenance has been performed and is up to date.



Refer to your bin operation manual for specific operating and safety information for your bin.

## 6.2. Start-up and Break-in

---

Although there are no operational restrictions on the conveyor when used for the first time, it is recommended that the following items be checked during the first hours of operation.

1. Check that the conveyor intake and discharge areas are free of obstructions.
2. Check conveyor belt alignment to ensure preset alignment does not vary under loaded conditions. See Maintenance Section for alignment instructions.
3. Check the conveyor belt tension. See Maintenance Section for tension instructions.
- ➔ 4. **Electric Drive Models:** Check the drive belt tension and alignment. See Maintenance Section for instructions.
5. Check the pinch roller bearings on the top drive pinch roller are not tight.
6. Visually inspect the conveyor, see Visual Inspection in Maintenance Section.
7. Check tightness of all bolts/nuts, fasteners, and hardware (re-torque if necessary).
8. Start the conveyor and operate normally, refer to power source instructions for further detail.
9. Be aware of unusual sounds. If any are heard, determine the source and stop the conveyor. Lock out and correct the problem before resuming work. If you are unsure of the problem or procedure, contact your local dealer.
10. Do not run the conveyor for long periods of time without material on the conveyor belt because it increases wear. Try to run only when moving material.
11. Stop the conveyor when it is empty of grain and lockout power, lower fully.

### Important

After the initial start-up and inspection, the conveyor should be shut down and visually inspected (see Maintenance Section) after approximately ten hours of operation.

## 6.3. Operation - Electric Motor Models

---

➡ When equipped with an Electric Motor:

1. Turn the electric motor on.
2. Run until the conveyor is empty.
3. Turn off motor and lock out power source.
4. Unplug the power cord, wrap around the equipment and secure to prevent dragging, especially when transporting or placing the conveyor.

## 6.4. Operation - Hydraulic Motor Models

---

1. Place all tractor controls in neutral.
2. Start the tractor and run at low idle.
3. Engage the tractor hydraulic control lever and increase the engine to desired speed.

**Note**

The correct operation of a hydraulic system is directly linked to the pump's ability to supply the correct oil flow and pressure. If you cannot obtain the correct belt speed, check with your dealer to ensure the power unit is delivering the correct oil volume and pressure.

4. Run until the belting is empty.
5. Reduce tractor engine speed to low idle.
6. Place hydraulic control lever in neutral.
7. Shut off engine and remove ignition key.
8. Disconnect hydraulic hoses, and wrap hose around frame to prevent dragging.

## 6.5. Loading Area

---

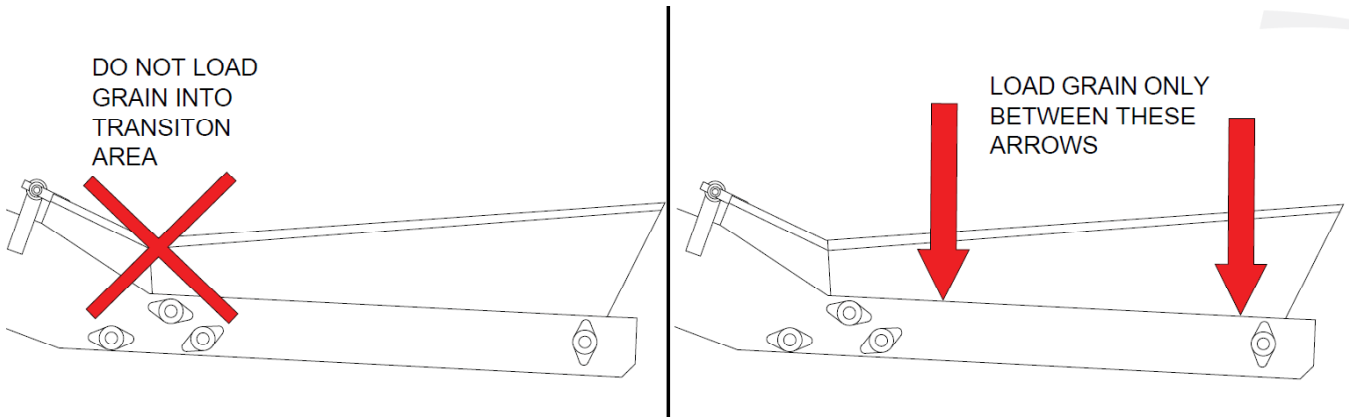
To achieve maximum capacity:

- Feed material onto the belt until the material tube clearance is 1/2".
- Direct the flow of material into the input hopper in the direction of the belt travel for the best capacity.

Do not:

- Unload material into the transition area.
- Flood feed the hopper.



**Figure 10. Conveyor Loading Zone**

## 6.6. Conveyor Belt Speed

The best results are obtained when the input drives are set to provide a conveyor belt speed of 500 to 600 ft/min on the 1500 series, and 600 to 650 ft/min on the 1800, 2000, and 2400 Series.

Count the number of belt revolutions per minute to determine belt speed. See Specifications for belt length.

### Note

Use the connector splice as a reference when counting belt revolutions.

To calculate, for example, 600ft/minute belt speed for a 47ft belt:

$$\frac{\text{BeltSpeed}}{\text{BeltLength}} = \frac{600}{47} = 12.76$$

Therefore, 12.76 or approximately 13 belt passes per minute will provide a 600ft/min belt speed.

Contact your dealer or the factory for the appropriate drive components to give the recommended belt speed.

If the belt speed is too low, conveyor may leak around transition area.

## 6.7. Emergency Shutdown

In an emergency situation:

1. Stop or shut down the power source immediately and lock out all power.
2. Stop the flow of material (if applicable).
3. Ensure the machine components come to a stop before inspecting.
4. Correct the emergency situation before resuming work.

## 6.8. Restarting with a Full Tube

When the conveyor is shut down inadvertently or due to an emergency, the tube may still be filled with grain.

1. With the power source locked out, remove as much of the grain as possible from the tube and intake using a shop vacuum or other tool. Do not use your hands.

**NOTICE** Starting under load may result in damage to the conveyor.

2. If guards or covers have been opened or removed, close or replace them before restarting the unit.
- ➔ 3. **Electric Drive Models:** It may be necessary to tighten the drive belts slightly to handle the heavier than normal loads.
- ➔ 4. **Hydraulic Drive Models:** Since the start-up torque loads are so much higher than normal when the conveyor belting is full, restart at low speed. Do not let the conveyor belt drive roller spin on the belt if conveying belt does not start moving immediately. This will damage the drive roller and conveying belt.
5. Once the conveyor has been started, you may resume normal operation.

## 6.9. Shutdown

---

When operation has been completed:

1. Once the conveyor is clear of grain, lock out the power source.
2. Lower the conveyor fully.
3. Clean out any remaining grain from the conveyor with a vacuum or sweep out.
4. Clean the entire work area.
5. Remove anchors, supports, and chocks.

## 6.10. Clean Out

---

After using your conveyor, follow the clean out steps below to ensure longer belt life and trouble free operation. Failure to clean out the conveyor can cause build up of product on the belt and roller shafts, causing spillage, roller misalignment, and excess wear/damage to the belt.

**WARNING** Failure to lock out power can cause severe injury.

1. Remove any product remaining in the hopper and spout with a vacuum or sweep out.
2. Remove debris from shafts, sheaves, and drive belts (as equipped).
3. Once the conveyor is empty of all product, check for damage on belt and lacing such as notches or cut outs. Any damage on belt may result in product getting under it creating a build-up. If belt replacement and re-lacing is necessary, refer to the Maintenance Section.

### **Important**

Ensure the conveyor is free from all product and debris to prevent build-up. Any build-up on belt and shaft becomes a source of spillage and can cause belt misalignment with the possibility of belt edges sustaining damage on the fixed structure. Build-up on the hopper and spout will cause the belt to wear faster due to drag.

4. Once cleaned out, cover intake to prevent moisture from collecting in hopper.

## 6.11. Conveying Fertilizer

---

Fertilizer may be conveyed using the conveyor when strictly operated at a reduced capacity and additional care is taken to thoroughly clean the conveyor after operation.



**Important**

Fertilizer weakens the belt lacing and warranty is void on all lacing used with fertilizer. The belt lacing may need to be replaced more often if you convey fertilizer.

**Additional Operating Requirements**

To prevent problems that can be caused by conveying fertilizer:

1. Do not allow fertilizer to fill over the edge of the belt. This will allow fertilizer to get under the belt and start building up.
2. Reduce the flow if the conveyor belt starts to slip. Denser fertilizers will slow the conveyor belt down due to the weight of the product. Too much material will cause the drive roller to slip and lead to additional wear on the roller.
3. Do not move fertilizer with your conveyor in humid, wet or rainy conditions. This will cause buildup of fertilizer under your conveyor belt.

**Additional Clean-Out Procedures**

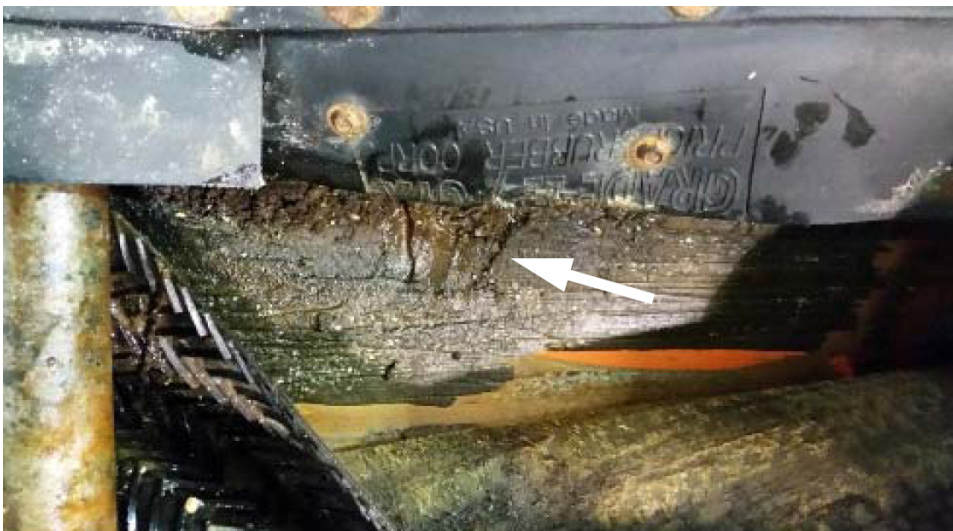
Proper cleaning will help to ensure longer belt life and prevent excess rust formation.

1. Run conveyor empty at full speed for 5-10 minutes after conveying fertilizer. This will help ensure that any product that may be under the belt will be cleaned out and prevent build up.

**⚠ WARNING** Do not attempt to manually remove build-up while conveyor is running.

2. Run the belt at low idle and inspect for damage on the belt and lacing, such as notches or cut outs caused by mice and normal wear. Any damage on the belt may result in fertilizer getting under the belt creating a buildup. Consider replacing the conveyor belt if it is in poor condition. If equipped with an electric motor, inspect on the belt return side with the electric motor not running. Turn on the conveyor to expose the belt that was previously in the tube. Turn off the conveyor and inspect the belt on the belt return, along with the lacing.
3. Shutdown and lockout power to the conveyor and vacuum or sweep out any remaining fertilizer from the hopper.
4. If buildup is evident on or under the belt, remove the buildup to ensure proper operation of the conveyor. When necessary remove fertilizer buildup from under the belt by scraping and washing the belt.

**Figure 11. Fertilizer Buildup at Hopper Transition**



## 6.12. Storage

---


After the season's use, the conveyor should be thoroughly inspected and prepared for storage. Repair or replace any worn or damaged components and perform maintenance as described in the Maintenance Section to prevent any unnecessary downtime at the start of the next season.

To ensure a long, trouble-free life, this procedure should be followed when preparing the unit for storage.

1. Remove all residual material from the hopper and the tube.
2. Stop the machine with the belt lacing inside the tube. This helps prevent the lacing from rusting.
3. Wash the entire conveyor thoroughly using a water hose or pressure washer to remove all dirt, mud, debris, or residue.
4. Inspect all moving or rotating parts to see if anything has become entangled in them. Remove any entangled material.
5. Touch up all paint nicks and scratches to prevent rusting.
6. Check tire pressure and inflate. For inflation pressure, refer to [Section 9. – Specifications on page 56](#).
7. Inspect the conveyor for cracks, tightness of fittings and fasteners, hydraulic hose cracks (if applicable). Have required repairs performed to replace worn or damaged components.
8. Store in an area that is dry, level, free of debris, and away from human activity. Store inside if possible.
9. Cover the motor with waterproof tarpaulin if stored outside to protect from weather.
10. Chock wheels.
11. Support intake on blocks to eliminate prolonged contact with the ground.
12. Lower the conveyor fully for storage.



# 7. Maintenance

 Before continuing, ensure you have completely read and understood this manual’s Safety section, in addition to the safety information in the section(s) below.

## 7.1. Maintenance Safety

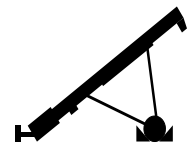
**WARNING**

- Keep components in good condition. Follow the maintenance procedures.
- Ensure the service area is clean, dry, and has sufficient lighting.
- Do not modify any components without written authorization from the manufacturer. Modification can be dangerous and result in serious injuries.
- Shut down and lock out power before maintaining equipment.
- After maintenance is complete, replace all guards, service doors, and/or covers.
- Use only genuine Hutchinson replacement parts or equivalent. Use of unauthorized parts will void warranty. If in doubt, contact Hutchinson or your local dealer.



**Before attempting maintenance of any kind:**

- Lower the conveyor fully.
- Chock wheels.
- Support tube if performing maintenance on the undercarriage assembly.
- **If equipped with hydraulics:** Before applying pressure to a hydraulic system, make sure all components are tight and that hoses and couplings are in good condition.



## 7.2. Maintenance Schedule

Proper maintenance habits mean a longer life, better efficiency, and safer operation. Please follow the Maintenance Schedule below. Keep good records of the hours the conveyor has been operated and the maintenance performed.


<b>Daily:</b>
<a href="#">Section 7.3. – Visually Inspect the Equipment on page 41</a>
<a href="#">Section 7.4. – Lubricate the Equipment on page 42</a>
<b>Monthly:</b>
<b>Hydraulic Drive Models:</b> <a href="#">Section 7.6. – Inspect Hydraulic Hoses and Fittings on page 42</a>

Section 7.7. – Inspect the Hopper Flashing on page 43
Section 7.8. – Check the Roller Bearings on page 43
Section 7.9. – Check the Roller Lagging on page 43
7.12. Inspect Belt Lacing on page 48
<b>Annually:</b>
<b>Hydraulic Drive Models:</b> Section 7.5. – Oil the Chain Coupler on page 42
Section 7.10. – Tension the Conveyor Belt on page 43
Section 7.11. – Align the Conveyor Belt on page 45
Section 7.15. – Clean and Wash the Equipment on page 50
<b>2–3 Years:</b>
7.13. Replace the Belt Lacing on page 48
<b>As Required:</b>
<b>Electric Drive Models:</b> Section 7.16. – Tension the Drive Belts on page 50
<b>Electric Drive Models:</b> Section 7.17. – Align the Drive Belts on page 51
<b>Electric Drive Models:</b> Section 7.18. – Replace the Drive Belts on page 51
Section 7.19. – Repack the Wheel Bearings with Grease on page 51
Section 7.20. – Inspect and Service the Hand Winch and Lift Cable on page 52
7.14. Replace the Conveyor Belt on page 48

## 7.3. Visually Inspect the Equipment

Check the following during a visual inspection:

1. Ensure all guards are in place and in good working order.
2. Examine the conveyor for damage or unusual wear.
3. Check tightness of bolts/nuts, fasteners, and hardware (re-torque if necessary).
4. Be sure all safety decals are in place and are legible.
5. Check that the discharge and intake area are free of obstructions.
6. Inspect all moving or rotating parts to see if anything has become entangled in them. Remove any entangled material.

 **WARNING** Lock out power before inspecting.

7. **When equipped:** Inspect hydraulic hoses and fittings for leaks and wear. Fix or replace where necessary.
8. Check wheel bolts are tight and examine tires for gashes, uneven wear, or loss of air pressure. See [Section 9. – Specifications on page 56](#) for recommended tire pressure.
9. Check all operating, lifting, and transport components. Replace damaged or worn parts before using the conveyor.
10. Inspect the winch cable for fraying, kinking, unwinding, or other possible damage.



## 7.4. Lubricate the Equipment

---

Your equipment can operate at top efficiency only if clean fluids and lubricants are used. Use clean containers to handle all fluids and lubricants. Store them in an area protected from dust, moisture, and other contaminants.

1. Wipe the grease fittings with a clean cloth before greasing to avoid injecting dirt and grit.
2. Use a hand-held grease gun for all greasing.
3. If fittings will not take grease, remove and clean thoroughly.
4. Replace fittings if they are broken or will not accept grease.

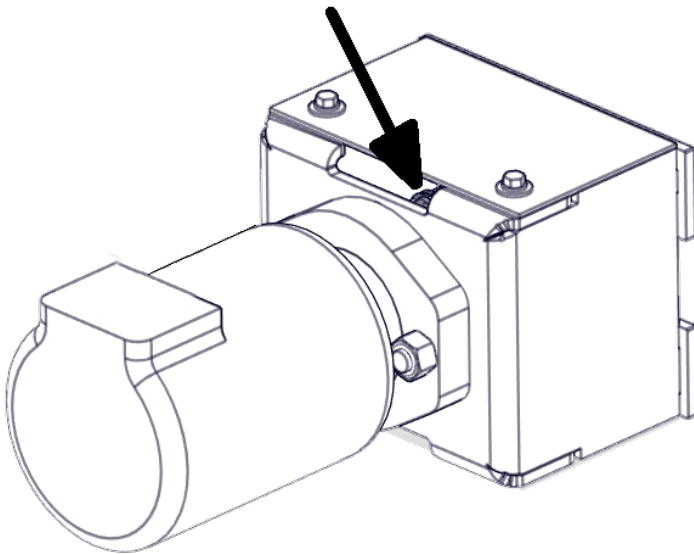
Use SAE multi-purpose high-temperature grease with extreme pressure (EP) performance. SAE multi-purpose lithium-based grease is also acceptable.

## 7.5. Oil the Chain Coupler

---

The chain coupler is located between the hydraulic motor and the conveyor's drive roller.

**Figure 12. Chain Coupler Location**



## 7.6. Inspect Hydraulic Hoses and Fittings

---

➡ When equipped:

1. Pressurize the system.
2. Using a piece of cardboard or wood, run it along the length of the hose and around all fittings.

**WARNING**

Escaping hydraulic fluid under pressure will cause serious injury if it penetrates the skin surface.

3. Replace the hose or tighten/replace the fitting if a leak is found. For replacement hoses, refer to [Section 9. – Specifications on page 56](#).
4. Replace any hose that is badly cut, nicked, abraded, or is separating from the crimped end of the fitting.
5. Secure hoses to the machine.

## 7.7. Inspect the Hopper Flashing

---

Check hopper flashing for wear and replace any that are worn. Worn flashing will cause hopper leakage.

## 7.8. Check the Roller Bearings

---

Check the roller bearings for wear. Any rollers making noise, getting hot while running, or that give should be replaced.

## 7.9. Check the Roller Lagging

---

Inspect roller lagging to see if it is showing signs of wear.

**NOTICE**

Operating the conveyor with a damaged roller will result in a damaged conveyor belt.

## 7.10. Tension the Conveyor Belt

---

Adjusting your conveyor belt for proper tension helps to ensure trouble-free operation and long belt life.

The conveyor belt only needs to be tight enough to not slip on the drive roller. If the belt is too loose, it will slip on the drive roller making a noticeable sound, slowing the belt down.

The conveyor belt should not be easy to pull from the hopper transition sides, otherwise the belt will require tensioning.

**NOTICE**

Failure to stop using a conveyor with a slipping belt will damage it and/or the drive roller lagging. In extreme cases, sections of burnt belt will have to be replaced. This type of damage is not covered by warranty.

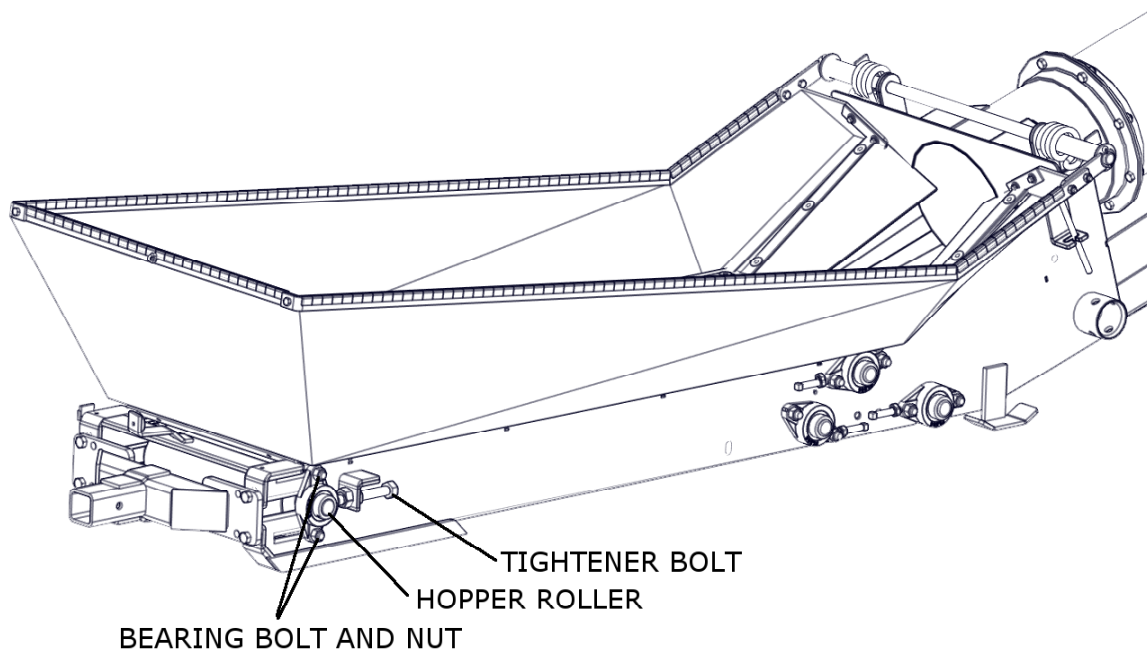
### To set correct conveyor belt tension:

1. Loosen the bearing bolts and jam nut (if included) at the hopper roller, see [Figure 13 on page 44](#).
2. Tighten the tightener bolts equally, use a tape measure to verify. The conveyor belt should deflect 1-2" when pushed down with a 5 lb force, or be difficult to pull from the sides of hopper transition.
3. Tighten the bearing bolts and jam nut (if included).
4. Ensure the hopper roller is tensioned equally by using a tape measure to check both sides.
5. Check the belt tension by running the conveyor for one minute. If the conveyor belt is not slipping, then proceed to next step; otherwise repeat from step 1.
6. After the conveyor belt has been tensioned, check the alignment of all rollers, see [Section 7.11. – Align the Conveyor Belt on page 45](#).



7. If the conveyor belt is still loose after tensioning, the belt needs to be shortened or replaced (depending on wear).

**Figure 13. Typical Hopper**

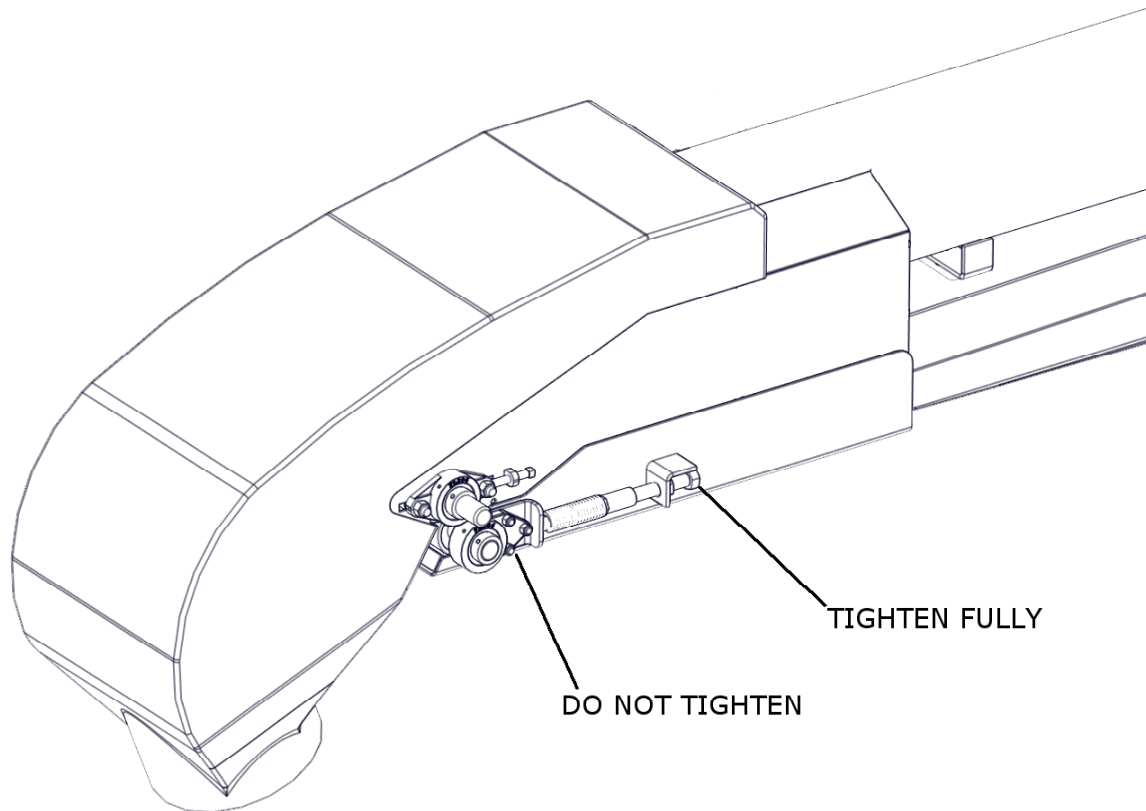


### 7.10.1 Top Drive Pinch Roller

➡ When equipped with a Top Drive Pinch Roller:

The top drive pinch roller should always be set loose, allowing the spring to pinch the conveyor belt. This should not normally require adjustment.

1. Do not tighten nuts. Bearing nuts must remain wiggle loose.
2. Tighten pinch spring, if loose.

**Figure 14. Top Drive Pinch Roller**

## 7.11. Align the Conveyor Belt

---

**⚠ WARNING** Failure to lock out power can cause severe injury.

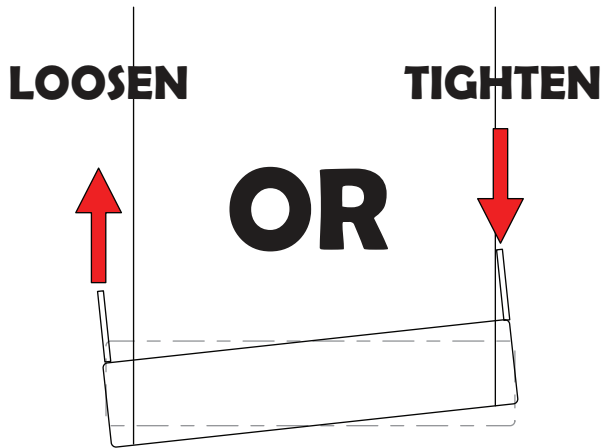
### Basic Conveyor Belt Alignment:

The conveyor belt will run straight when all of the rollers are straight.

Loosen or tighten the adjustment bolt(s) to align the conveyor belt. Tighten the side the belt has moved toward, or loosen the side the belt has moved away from.



Figure 15. Roller out of Alignment

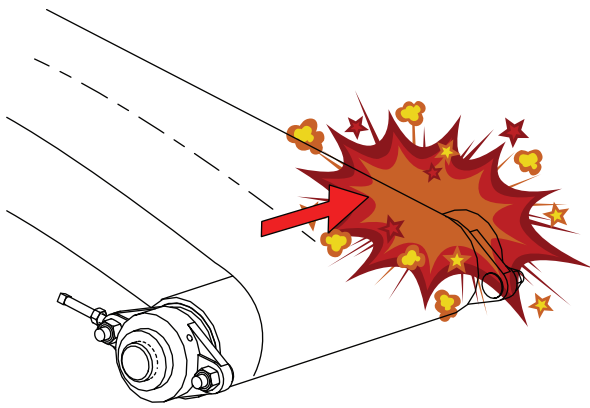
**Before Aligning the Belt:**

- The conveyor must be empty of all grain.
- Wait until the belt makes a complete revolution before adjusting the rollers. Some belts may have uneven edges, appearing misaligned.

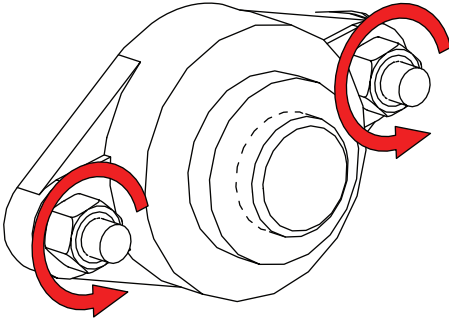
**To Align the Belt:**

If your belt is tracking off-center, follow the sections and steps in the order following to center it.

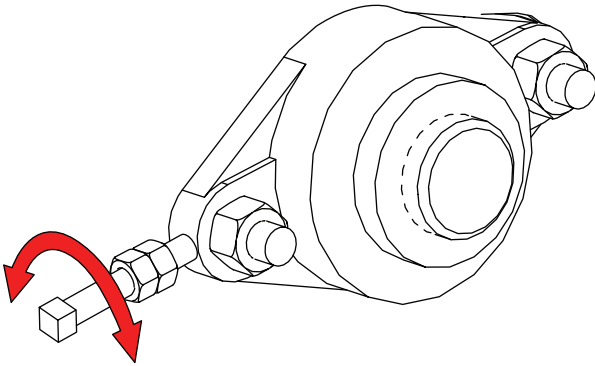
Figure 16. Belt Tracking to One Side

**7.11.1 Adjust the Rollers**

1. Loosen bearing nuts and jam nuts (if equipped).

**Figure 17. Loosen the Bearing Nuts**

2. Rotate adjustment bolt 1/2 turn.

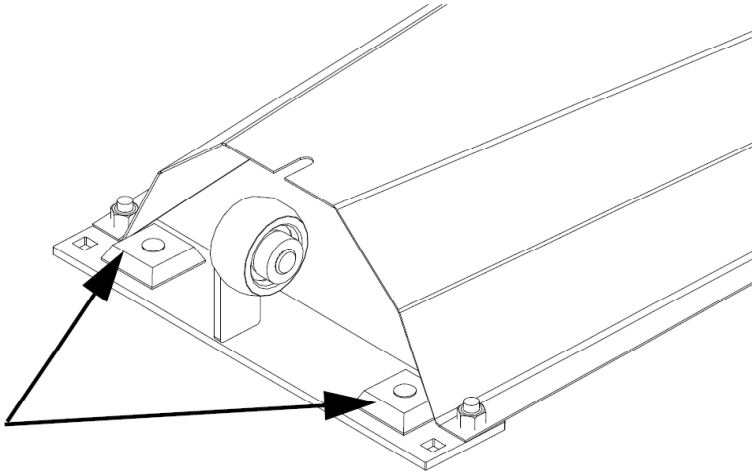
**Figure 18. Rotate the Adjustment Bolt**

3. Restart conveyor and run empty for 1 minute.
4. Stop the conveyor and remove ignition key or lock out the power source.
5. If the belt has centered, move to next step. If not, repeat Step 2 to Step 4 until the belt is centered.
6. Tighten the bearing bolts and jam nut (if equipped).
7. Replace any guards that were removed.

### ***7.11.2 Adjust the Belt Return Wear Blocks***

1. Adjust the wear blocks by rotating them 90 or 180 degrees. If they are worn down, replace the wear blocks.



**Figure 19. Belt Return Wear Blocks**

2. Replace the guards if removed.

## 7.12. Inspect Belt Lacing

---

Inspect the condition of the belt lacing, if any clips are worn through, replace all lacing.

## 7.13. Replace the Belt Lacing

---

1. Rotate the conveyor belt until the lacing is by the hopper or is easily accessible.
2. Loosen the conveyor belt and remove the lacing retainer clip and pin.
3. Using a square and sharp knife, cut the lacing off right behind the lacing clips. The cut belt **MUST** have a square end.
4. Use a knife to cut Chevron pattern off 1" back from the end of the belt. This ensures that the lacing is centered and fully seated on the belt.
5. Use a lacing tool to install new lacing clips. Lacing clips are one clip shorter than the belt width. For example: the lacing for a 15" wide belt is 14 clips. Center the lacing on the belt and install the lacing as per instructions on the lacing tool.
6. Reattach the conveyor belt ends together. If required, use a ratchet strap clamped to both ends of the belt to cinch the belting ends together. [Figure 20 on page 49](#).
7. Install the lacing pin and crimp the retainer clips onto each end of the lacing pin. [Figure 21 on page 50](#).
8. Remove the ratchet strap and tighten the conveyor belt (see "Conveyor Belt Tension").
9. Check and set the belt alignment (see "Conveyor Belt Alignment").
10. Engage the conveyor drive. Allow the conveyor to run for 30 seconds, then shut down the conveyor and inspect the lacing.

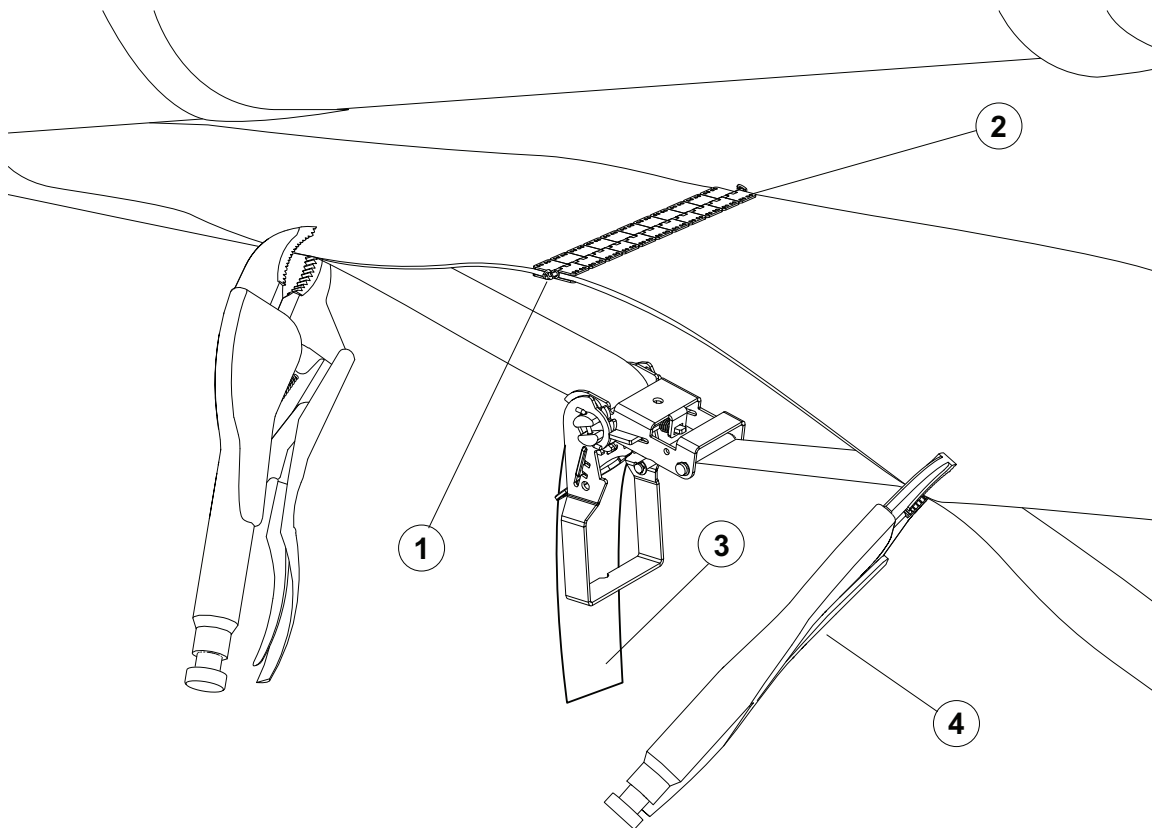
## 7.14. Replace the Conveyor Belt

---

1. Rotate the conveyor belt until the lacing is by the hopper or is easily accessible.

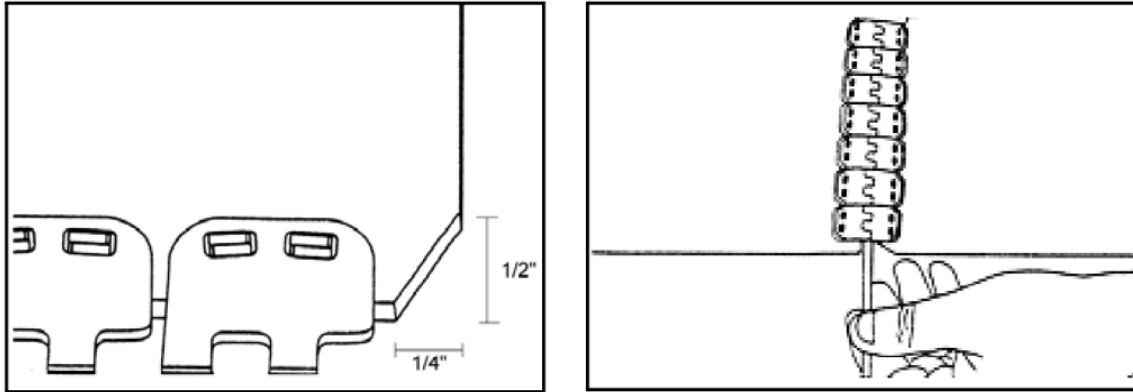
2. Move the tension roller to its loosest position.
3. Pull all the slack to the lacing area.
4. Remove the lacing retainer clip and pin.
5. Attach one end of the replacement belt to the belt end being removed, closest to the hopper.
6. Pull the old belt out and the new belt will be threaded into place.
7. Disconnect the old belt.
8. Reattach conveyor belt ends together. If required, use a ratchet strap clamped to both ends of belt to cinch belting ends together. [Figure 20 on page 49.](#)

**Figure 20. Using the Ratchet Strap**



9. Install the lacing pin and crimp the retainer clips onto each end of the lacing pin, see [Figure 21.](#)
10. Remove the ratchet strap and tighten the conveyor belt (see “Tension the Conveyor Belt”).
11. Check and set the belt alignment (see “Align the Conveyor Belt”).
12. Engage the conveyor drive. Allow it to run for 30 seconds, then shut down the conveyor and inspect the lacing.



**Figure 21. Lacing the Conveyor Belt**

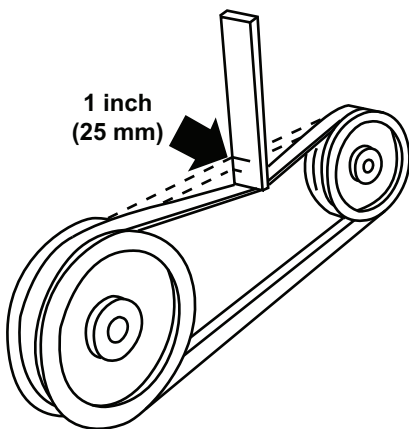
## 7.15. Clean and Wash the Equipment

1. Clean out excess grain from all areas of the conveyor.
2. Make sure water can drain from the conveyor tube and intake, then wash the tube with a water hose or pressure washer until all dirt, mud, debris, or residue is gone.
3. Provide sufficient time for the water to drain from the conveyor.

## 7.16. Tension the Drive Belts

➡ When equipped:

1. Remove guard and push on the center of the belt span with a force of approximately 5 lb.
2. The belts will deflect approximately 1" (25 mm) when properly tensioned.

**Figure 22. Typical Drive Belt Tensioning**

3. Tighten or loosen the drive belts (or idler pulley when equipped) to achieve the proper tension.

### Important

The drive belt should be just tight enough to not slip on the drive pulley when operating. If the belt is too loose, it will slip, possibly causing a squeaking sound and slowing the belt down. If the belt is too tight, it will cause excess wear.

4. Reattach and secure guard. Start system to ensure proper operation.

## 7.17. Align the Drive Belts

---

➡ When equipped:

1. Lay a straight edge across the pulley faces to check the alignment.
2. Use the pulley hub to move the pulley to the required position for alignment.
3. Tighten the hub bolts to secure pulley on the drive shaft.
4. Check the belt tension.
5. Reattach and secure the guard.

## 7.18. Replace the Drive Belts

---

➡ When equipped:

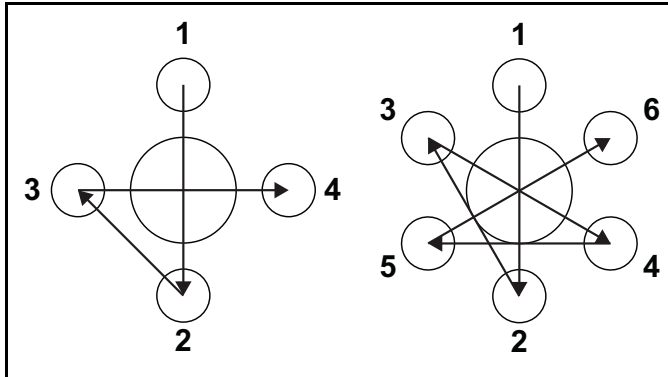
1. Fully loosen the drive belts.
2. Remove and replace the old belts.
3. Tighten the drive belts as described in Belt Tension.
4. Align the drive belts as described in Belt Alignment.
5. Reattach and secure the guard.

## 7.19. Repack the Wheel Bearings with Grease

---

1. Block wheels and ensure unit is stable.
2. Remove the wheel bolts and the wheels.
3. Clean wheel and hub mounting surfaces to ensure there is no rust or debris.
4. Remove the wheel bearing and pack with grease. Use SAE multi-purpose high-temperature grease with extreme pressure (EP) performance. SAE multi-purpose lithium-based grease is also acceptable.
5. Tighten the wheel bolts (diagonal pattern) with a torque wrench to 100 ft-lb ( $\pm 10$  ft-lb) of torque. Inspect to make sure the wheel is sitting flush with the hub.



**Figure 23. Diagonal Pattern for 4-bolt and 6-bolt Tires**

## 7.20. Inspect and Service the Hand Winch and Lift Cable

➡ When equipped:

**⚠ WARNING** Place conveyor in fully lowered position with cable slack.

1. Inspect the cable for damage such as fraying, kinking, or unwinding. Replace if damaged (see below).
2. Check to make sure cable clamps are secure.
3. Oil cable pulleys as needed.
4. Keep a film of grease on the gears. Occasionally oil the bushings, drum shaft, and ratchet.
5. Do not get oil or grease on brake discs.
6. Replace brake discs if less than 1/16" (1.6 mm) thick.
7. Check for proper ratchet pawl operation:
  - When cranking in (clockwise) = loud clicking
  - When cranking out (counterclockwise) = no clicking and ratchet pawl fully engaged into gear teeth.

### To Replace the Lift Cable:

1. Unwind the winch drum until cable is slack and remove all cable clamps.
2. Free the cable from the winch and pulleys.
3. Remove the cable clamps that secure the hook in place.
4. Reverse the above steps to install the new cable.

# 8. Troubleshooting



Before continuing, ensure you have completely read and understood this manual's Safety section, in addition to the safety information in the section(s) below.



Shut down and lock out all power sources before diagnosing any of the causes or attempting any of the solutions below.

In the following section, we have listed some causes and solutions to some of the problems you may encounter.

If you encounter a problem that is difficult to solve, even after having read through this section, please contact your local dealer or distributor. Before you contact them, please have this operation manual and the serial number from your machine ready.

## Conveyor

Problem	Cause	Solution
Low conveying capacity.	Conveyor angle is too high.	Re-position with lower tube angle, see Operation.
	Incorrect belt speed.	Verify and adjust belt speed to appropriate speed, see Belt Speed in Operation.
	Conveyor belt slipping.	Tighten conveyor belt, see Conveyor Belt Tension in Maintenance.
	<b>When equipped:</b> Drive belts slipping.	Tighten belts, see Drive Belt Tension in Maintenance.
Low capacity for some grains.	Smaller and smoother grains will slide at shallower angles.	Reduce conveyor height, see Conveyor Operating Angles in Operation.
Conveyor belt slipping.	Conveying belt loose.	Tighten and align belt, see Belt Tension and Belt Alignment in Maintenance.
	Drive roller lagging worn or damaged.	Replace drive roller lagging, see dealer.
	<b>When equipped:</b> Drive belts loose.	Tighten belts, see Drive Belt Tension in Maintenance.
	Belt frozen to tube from operating in high humidity in cold conditions.	Remove conveyor from area of high humidity and warm belt to de-ice.
Excessive conveyor belt edge fraying.	Belt not aligned.	Align belt, see Belt Alignment in Maintenance.



Problem	Cause	Solution
Conveyor belt loose.	Belt stretches over time.	Re-tension belt, see Belt Tension in Maintenance.
		If belt is fully tensioned, you may need to shorten belt and re-lace, see Belt Relacing in Maintenance.
Grain leaking from conveyor hopper.	Belt not aligned (centered).	Align belt, see Belt Alignment in Maintenance.
	Flashing installed incorrectly or worn.	Inspect flashing for wear and replace if required.
	Hopper cloth worn or damaged.	Replace damaged hopper cloth.
	<b>When equipped:</b> Transition filler rings are worn.	Replace transition filler rings.
Hopper cloth collapsing under grain.	Misaligned or broken spring (s).	Check spring installation and repair as required.
	Pivot shafts improperly installed.	On some machines, switching pivot shafts left to right will increase hopper tension.
Grain leaking from conveyor discharge between belt and tube.	Belt not aligned (centered).	Align belt, see Belt Alignment in Maintenance.
Grain leaking from conveyor discharge between hood and belt.	Belt speed is too fast, hood plugging.	Decrease belt speed, see Belt Speed in Operation.
U-clamps or brackets sliding on tube.	U-clamps or brackets not properly crimped to tube.	Contact dealer or Hutchinson to correct positioning.

#### Frame/Undercarriage with Hand Winch

Problem	Cause	Solution
The conveyor will not raise or lower.	The conveyor is already at its maximum or minimum height.	If at maximum height, lower the conveyor.
	Obstruction in the slide.	Clear the obstruction.

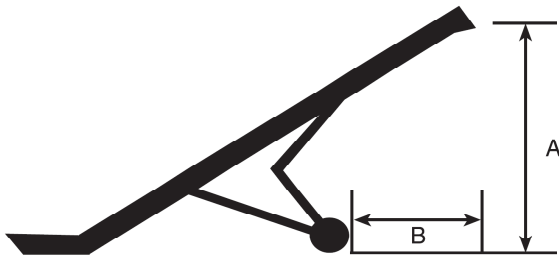
Problem	Cause	Solution
	Faulty cable.	Replace cable.
	Faulty winch.	Consult your local dealer.
	The bottom or top of the conveyor is obstructed.	Clear the obstruction.
The conveyor will not stay elevated.	Faulty winch.	Lower conveyor to transport position and repair or replace winch.

## Drive

Problem	Cause	Solution
Drive making noise.	<b>Electric Drive:</b> Slipping drive belt.	Tighten belts, see Drive Belt Tension in Maintenance.
	Hot shaft, pulley or bearing.	Overheated components indicate a failed bearing that must be repaired.
	Broken drive roller.	Replace damaged component.



# 9. Specifications



Model	Belt Length	Weight lbs	Up - Operation		Down - Transport		Width (ft)	HP PTO	HP Elec	HP Gas	HP Hyd (in <sup>3</sup> )
			A (ft)	B (ft)	A (ft)	B (ft)					
1535 TD-Elec	83'1"	1660	17	15.4	10	16.6	7.5	N/A	10 HP	N/A	N/A
1535 TD-Hyd	83'1"	1660	16.7-5	16.8	18.2	14.7	7.5	N/A	N/A	N/A	6.2 (2000 SERIES)
1545 TD-Elec	102'5"	2380	22.3	21.3	13.2	22.0	7.5	N/A	15 HP	N/A	N/A
1545 TD-Hyd	102'5"	2440	22.5	22.7	11.5	24.6	7.5	N/A	10 HP	N/A	6.2 (2000 SERIES)

# 10. Hutchinson/Mayrath Warranty

For a period of (1) year after receipt of goods by the original consumer buyer, Hutchinson/Mayrath will supply free of charge replacement parts for parts that prove defective in workmanship or material. Defective parts must be returned freight prepaid to a specified Hutchinson/Mayrath location. Only Hutchinson/Mayrath original repair parts may be used for warranty repairs.

This limited warranty does not extend to parts designed to wear in normal operation and be replaced periodically; or to damage caused by negligence, accident, abuse or improper installation or operation.

GOODS NOT MANUFACTURED BY HUTCHINSON/MAYRATH CARRY ONLY THE MANUFACTURER'S WARRANTY.

THIS UNDERTAKING IS IN LIEU OF ALL OTHER WARRANTIES, EXPRESSED OR IMPLIED, INCLUDING MERCHANTABILITY AND FITNESS FOR A PARTICULAR PURPOSE.

FAILURE TO FOLLOW THE INSTRUCTIONS CONTAINED IN THE OWNER'S & OPERATOR'S MANUALS AND THE ITEMS LISTED BELOW WILL RESULT IN THE VOIDING OF THIS LIMITED WARRANTY.

1. Improper assembly, including failure to properly install all safety equipment.
2. Improper installation.
3. Unauthorized alternations of goods.
4. Goods operated when obviously in need of repair.
5. Use of unauthorized repair parts.
6. Irresponsible operation.
7. Used to handle materials other than free flowing, nonabrasive and dry materials, as intended.
8. Damaged through abusive use or accident.

**Limitation of Liability:** BUYER AGREES THAT IN NO EVENT SHALL HUTCHINSON/MAYRATH HAVE LIABILITY FOR DIRECT DAMAGES IN EXCESS OF THE CONTRACT PRICE OF THE GOODS IN RESPECT OF WHICH CLAIM IS MADE. BUYER FURTHER AGREES THAT IN NO EVENT SHALL HUTCHINSON/MAYRATH ON ANY CLAIM OF ANY KIND HAVE LIABILITY FOR LOSS OF USE, LOSS OF PROFITS, OR FOR ANY INDIRECT, INCIDENTAL OR CONSEQUENTIAL DAMAGES.

**Modifications:** It is the policy of Hutchinson/Mayrath to improve its product whenever possible and practical to do so. We reserve the right to make changes, improvements and modifications at any time without incurring the obligation to make such changes, improvements and modifications on any equipment sold previously.



# **HUTCHINSON**

514 W. Crawford Street  
Clay Center, Kansas, 67432 USA  
Phone: (800) 523-6993 or (785) 632-2161  
Fax: (785) 632-5964  
Website: [www.hutchinson-mayrath.com](http://www.hutchinson-mayrath.com)  
Email: [sales@hutchinson-mayrath.com](mailto:sales@hutchinson-mayrath.com)

©Ag Growth International Inc. 2018  
Printed in Canada

