



A296/A266 Hydraulic Winch Kit Portable Grain Auger Installation Instructions

Applicable Models:

Westfield MKX, Westfield X, AGI X, Hutchinson HX, Mayrath HX 10/13 Series



Read and understand the safety information in the Portable Grain Auger manuals before proceeding. Read and understand the instructions in this manual before installing the Hydraulic Winch Kit. Fully disengage and lock out the Portable Grain Auger before installing.

Pre-Installation Instructions

- Familiarize yourself with all the required hardware. Kit A296 is for MKX10, X10 and HX10 augers. Kit A266 is for MKX13, X13, and HX13 augers.
- Arrange all parts for easy access.

Hydraulic Winch Installation

1. Unwind the cable from the manual winch spool and disconnect the cable from the spool by loosening or removing the cable clamp and pulling the cable free of the spool.
2. Disconnect the manual winch from the auger boot.
3. Install the hydraulic winch (see [Figure 1](#) or [Figure 2](#)).
4. **For 10 series:** Install the pulley guide onto the lift arm (see [Figure 1](#)).

Figure 1. Installing the Hydraulic Winch (MKX10, X10, HX10)

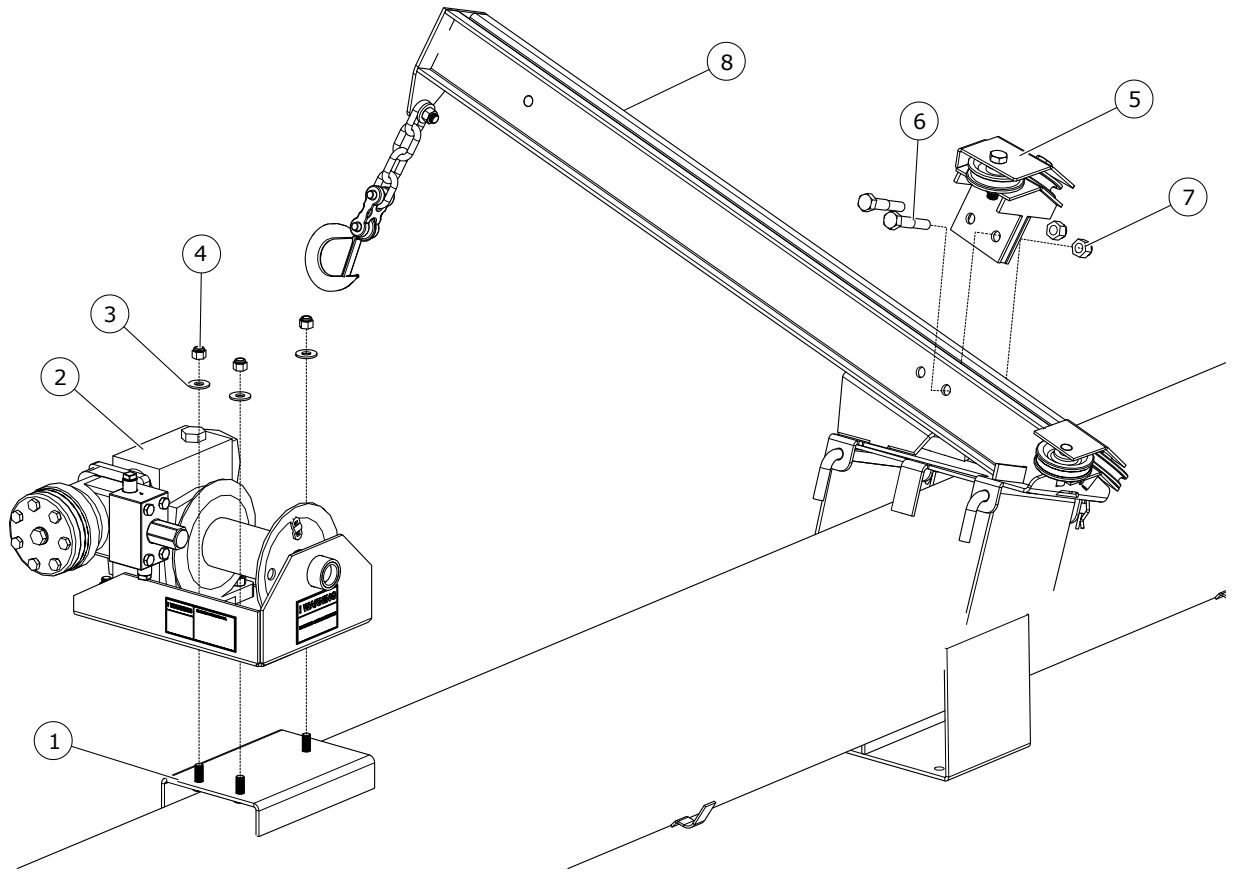

1	Winch mounting plate	5	Pulley guide
2	Hydraulic winch	6	Bolt, 1/2" x 2-1/2"
3	Flat washer, 3/8"	7	Locknut, 1/2"
4	Locknut, 3/8"	8	Lift Arm

Figure 2. Installing the Hydraulic Winch (MKX13, X13, HX13)

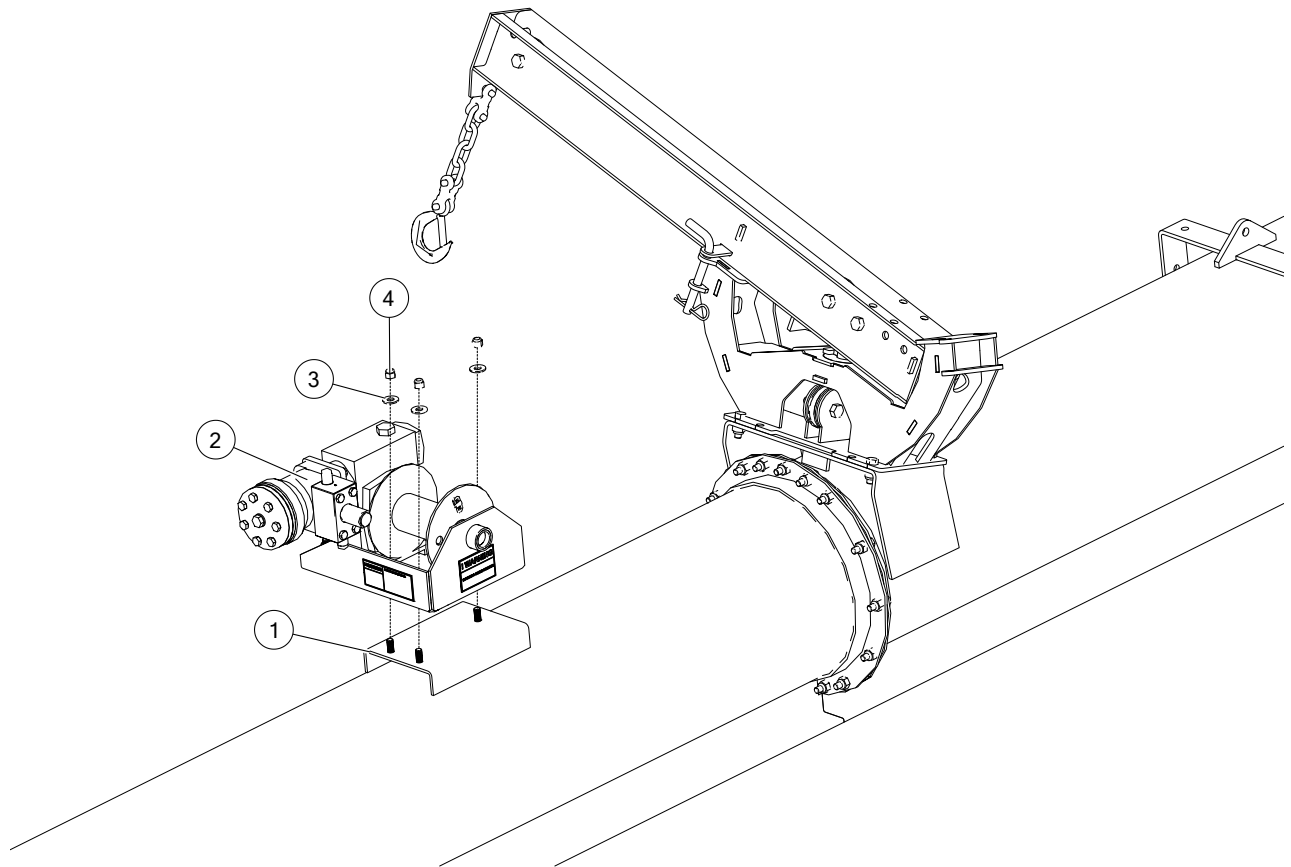

1	Winch mounting plate	3	Flat washer, 3/8"
2	Hydraulic winch	4	Locknut, 3/8"

- For **10 series**: Ensure that the winch cable feeds through the two lift arm pulleys (at the top of the lift arm and at the pulley guide), then feed the winch cable under the spool and connect it to the spool (minimum 3 wraps around the spool, feed cable through hole in side of spool, and secure with clamp and clamp hardware) as shown in [Figure 3](#).

Figure 3. Installing the Winch Cable (MKX10, X10, HX10)

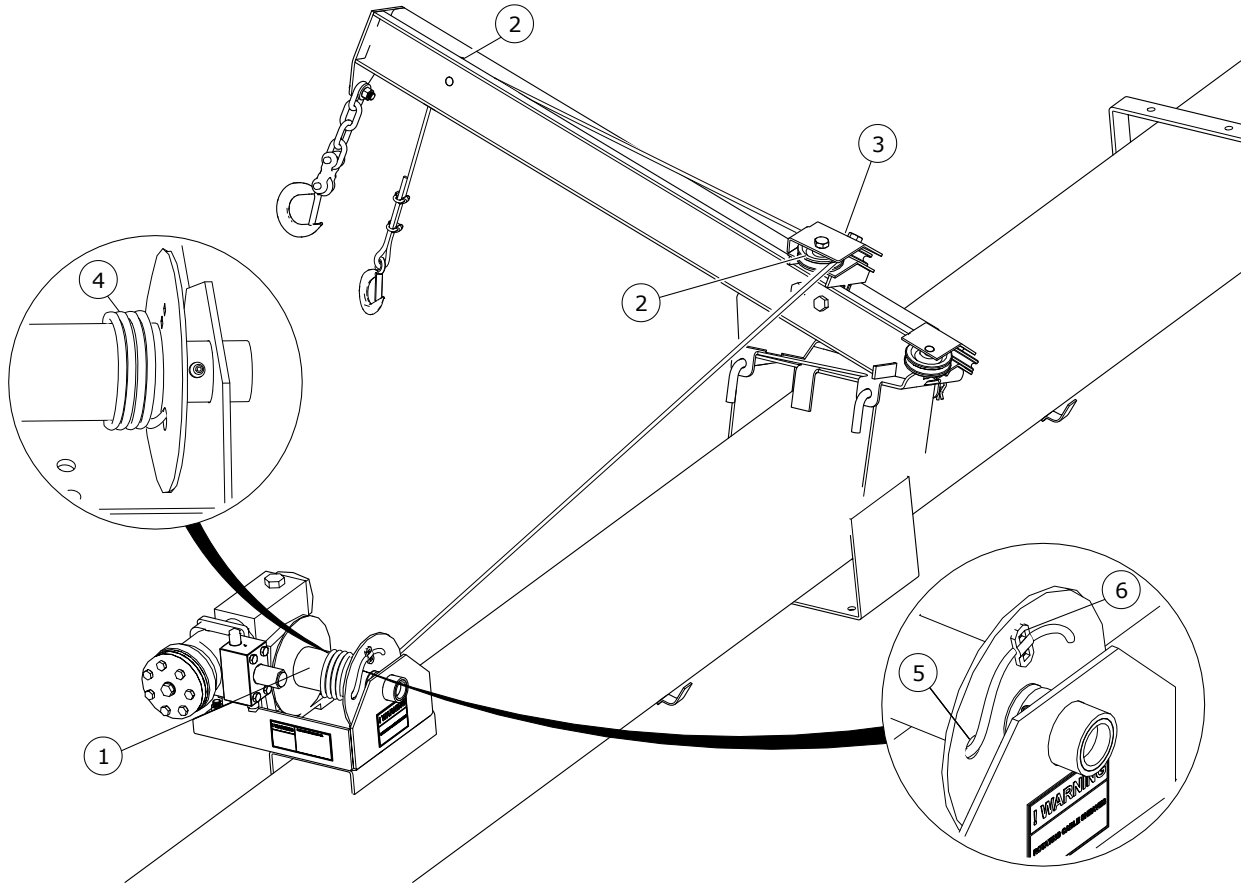

1	Spool	4	Winch cable
2	Pulley	5	Thread Cable Through Hole
3	Pulley guide	6	Clamp

6. **For 13 series:** Ensure that the winch cable feeds through the three lift arm pulleys (at the top of the lift arm and at the lift arm base), then feed the winch cable under the spool and connect it to the spool (minimum 3 wraps around the spool, feed cable through hole in side of spool, and secure with clamp and clamp hardware) as shown in Figure 4.

Figure 4. Installing the Winch Cable (MKX13, X13, HX13)

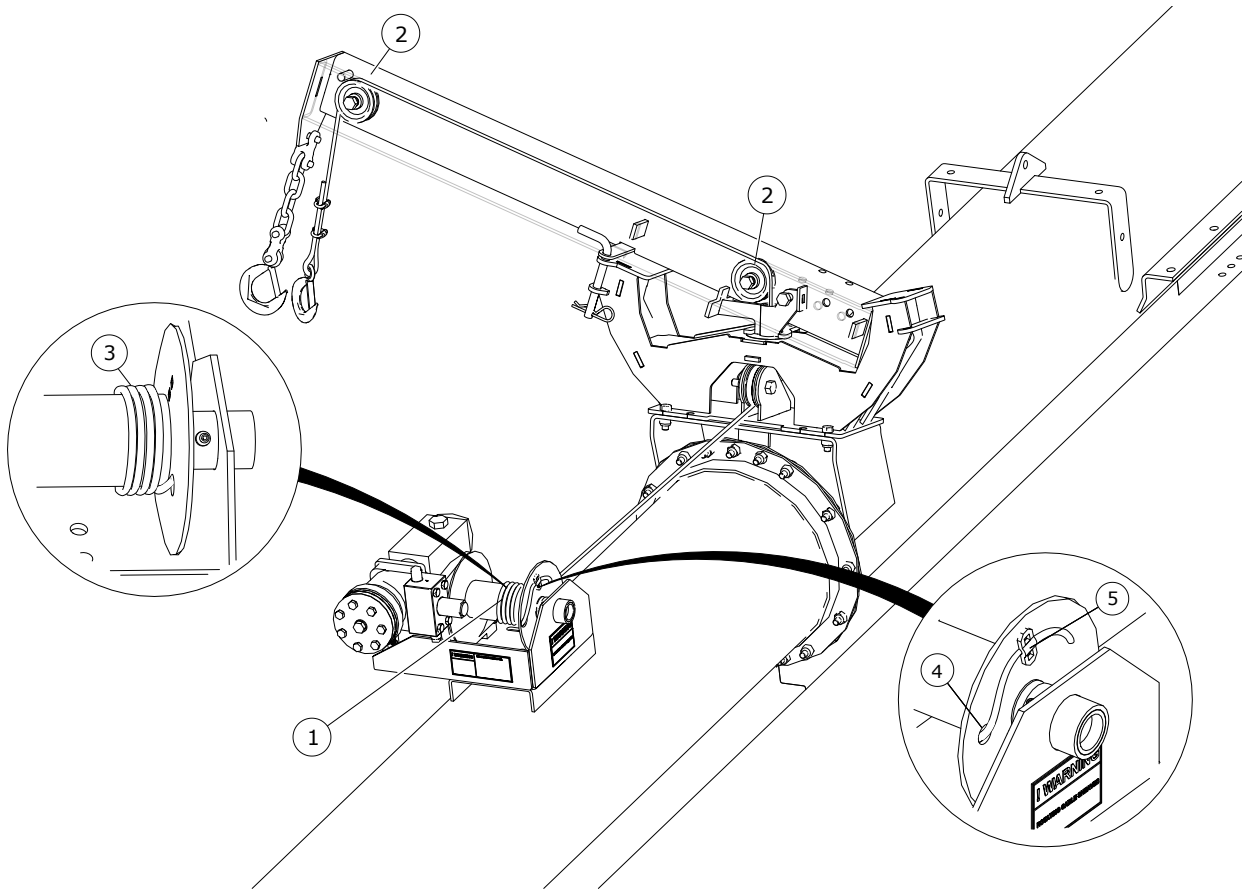

1	Spool	4	Thread Cable Through Hole
2	Pulley	5	Clamp
3	Winch cable		

7. Attach the double hose holder to the PTO bracket with a 3/8" x 1" bolt and locknut.

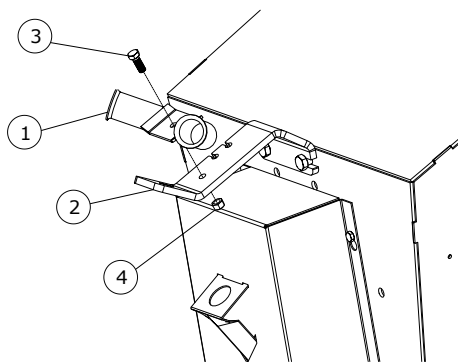

1	Double hose holder
2	PTO bracket
3	Bolt, 3/8" x 1"
4	Locknut, 3/8"

8. Connect hydraulic hose between the tractor and winch.

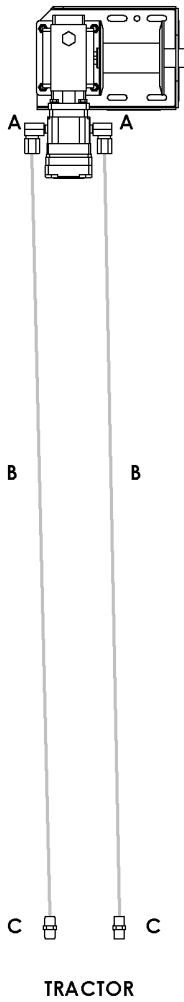

A	Steel elbow 90, 1/2 FNPSM x 3/8 MNPT
B	For 10 Series: 3/8" x 215" hydraulic hose
	For 13 Series: 1/2" x 236" hydraulic hose
C	Pioneer coupler

AGI is a leading provider of equipment solutions for agriculture bulk commodities including seed, fertilizer, grain, and feed systems with a growing platform in providing equipment and solutions for food processing facilities. AGI has manufacturing facilities in Canada, the United States, the United Kingdom, Brazil, South Africa, India and Italy and distributes its products globally.



P.O. Box 39, Rosenort, Manitoba, R0G 1W0 Canada
 P 866.467.7207 (Canada & USA) or 204.746.2396 | F 866.768.4852 | E sales@grainaugers.com

AGGROWTH.COM aggrowthintl
 ©Ag Growth International Inc. 2021 | Printed in Canada