

Catwalk

Grain Bin Installation and Storage Instructions

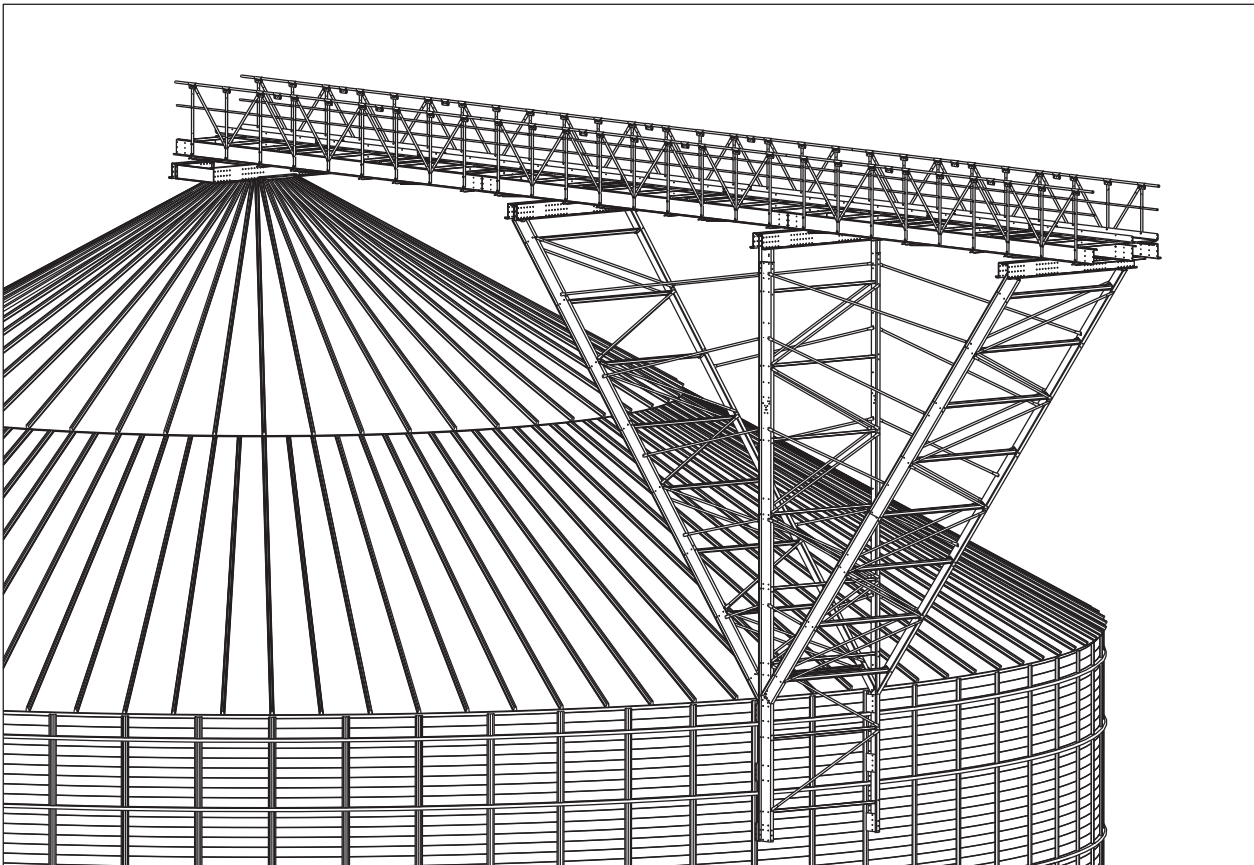

Read this manual before using product. Failure to follow instructions and safety precautions can result in serious injury, death, or property damage. Keep manual for future reference.

Part Number: 213440 R13

Revised: November 2020

Original Instructions

New in this Manual

The following changes have been made in this revision of the manual:

Description	Section
Falling Hazard decal 8110-00136 has been replaced by new decal 8110-00228.	Figure 1 on page 8

CONTENTS

1. Introduction	5
2. Safety.....	6
2.1 Safety Alert Symbol and Signal Words.....	6
2.2 General Safety	6
2.3 Personal Protective Equipment.....	7
2.4 Safety Decals	7
2.5 Decal Installation/Replacement	7
2.6 Safety Decal Locations and Details	8
3. Before You Begin	11
3.1 Bin Design and Capacity.....	11
3.1.1 Roof Design Capacities for Non-Structural Roofs.....	12
3.1.2 Roof Design Capacities for Structural Roofs.....	13
3.1.3 Roof Snow Load vs. Ground Snow Load	13
3.2 Guidelines for Supporting Catwalks and other External Loads on Westeel.....	14
3.3 Foundation Design and Loads	15
3.4 Site and Assembly	15
3.5 Methods of Installation	15
3.6 Critical Assembly Requirements	16
3.7 Product Storage.....	17
3.8 Grain Bin Use.....	18
3.9 Important Notes.....	18
4. Preparation	19
4.1 Check Shipment.....	19
4.2 List of Tools and Equipment.....	19
4.3 Order Optional Equipment.....	19
5. Assembly	20
5.1 Assembly Safety	20
5.2 Structure of this Manual	20
5.3 Introduction to Westeel’s Catwalk Systems	20
5.3.1 Versions of the Westeel Catwalk System	20
5.3.2 Catwalk Modules.....	21
5.3.3 Catwalk Supports	21
5.3.4 Catwalk Accessories	21
5.3.5 Planning.....	22
5.4 Standard Duty Catwalk Section Assembly	23
5.5 Heavy Duty Catwalk Section Assembly.....	29
5.6 Base Module Variations	31
5.6.1 Single Walkway	31
5.6.2 Double Walkway	32
5.6.3 Walkway/Conveyor/Walkway (WCW)	33
5.7 Catwalk Joiner Module Assembly	34
5.7.1 Standard Duty Joiner Modules.....	35
5.7.2 Heavy Duty Joiner Modules	38
5.7.3 Thermal Joint.....	40
5.8 End Modules.....	42
5.8.1 Standard Duty End Modules	42

5.8.2 Shortened End Modules.....	45
5.8.3 End Module in Combination with a Service Platform	47
5.8.4 Punched Walkway Options	48
5.8.5 Heavy Duty End Module	49
5.9 Service Platform Module Assembly	50
5.9.1 Standard Duty Service Platform Module	50
5.9.2 Heavy Duty Service Platforms.....	54
5.9.3 Service Platform Insert Module	55
5.10 Cross Catwalk Modules	56
5.10.1 Standard Duty Cross Catwalk Module Assembly.....	57
5.10.2 Heavy Duty Cross Catwalk Module Assembly	60
5.10.3 Cross Catwalk Variations.....	61
5.11 Peak Ring Support Module	61
5.11.1 Non-Structural Roofs.....	63
5.11.2 Structural Roofs.....	64
5.12 Catwalk Access	65
5.12.1 Ladder Positioning.....	66
5.12.2 Securing the Top of the Ladder	66
5.12.3 Securing the Bottom of the Ladder	68
5.12.4 Access Step.....	71
5.12.5 Bar Grating Walkway Considerations	72
5.12.6 Punched Platform Walkway Considerations.....	73
5.12.7 Ladder Pass-Through Rails	73
5.12.8 Catwalk Handrail Considerations.....	75
5.12.9 Catwalk Self-Closing Gate Installation	75
5.12.10 Heavy Duty Catwalk Access Variations	78
5.13 Goal Post and Knee Brace Modules.....	78
5.13.1 Connection to the Grain Bin	79
5.13.2 Goal Post Assembly.....	80
5.13.3 Knee Support Assembly	82
5.13.4 Catwalk Connectors.....	84
5.13.5 Connecting Goal Posts and Knee Supports.....	86
5.13.6 Connection to Grain Bin.....	89
5.13.7 Alternative and Additional Bracing.....	91
6. Appendix	95
6.1 Catwalk Parts Box Part Identification	95
6.2 Hardware Usage	98
7. Limited Warranty: Westeel Grain Bin Products	100

1. Introduction

Before assembling, please read this manual. Familiarize yourself with the process and the necessary precautions for efficient and safe assembly of this Westeel Catwalk.

Everyone present at the assembly site is required to be familiar with all safety precautions.

Keep this manual available for frequent reference and review it with new personnel. Call your local distributor or dealer if you need assistance or additional information.

2. Safety

2.1. Safety Alert Symbol and Signal Words



This safety alert symbol indicates important safety messages in this manual. When you see this symbol, be alert to the possibility of injury or death, carefully read the message that follows, and inform others.

Signal Words: Note the use of the signal words **DANGER**, **WARNING**, **CAUTION**, and **NOTICE** with the safety messages. The appropriate signal word for each message has been selected using the definitions below as a guideline.



DANGER Indicates an imminently hazardous situation that, if not avoided, will result in serious injury or death.



WARNING Indicates a hazardous situation that, if not avoided, could result in serious injury or death.



CAUTION Indicates a hazardous situation that, if not avoided, may result in minor or moderate injury.



NOTICE Indicates a potentially hazardous situation that, if not avoided, may result in property damage.

2.2. General Safety

Read and understand all safety instructions, safety decals, and manuals and follow them when assembling the equipment.

- Only experienced personnel who are familiar with this type of assembly and installation should perform this work. Untrained assemblers/installers expose themselves and bystanders to possible serious injury or death.
- Do not modify the catwalk in any way or deviate from the instructions in this manual without written permission from the manufacturer. Unauthorized modification or methods may impair the function and/or safety. Any unauthorized modification will void the warranty.
- Follow a health and safety program for your worksite. Contact your local occupational health and safety organization for information.
- Contact your local representative or Westeel if you need assistance or additional information.
- Always follow applicable local codes and regulations.



2.3. Personal Protective Equipment

The following Personal Protective Equipment (PPE) should be worn when installing the equipment.

Safety Glasses

- Wear safety glasses at all times to protect eyes from debris.



Coveralls

- Wear coveralls to protect skin.



Hard Hat

- Wear a hard hat to help protect your head.



Steel-Toe Boots

- Wear steel-toe boots to protect feet from falling debris.



Work Gloves

- Wear work gloves to protect your hands from sharp and rough edges.



2.4. Safety Decals

- Keep safety decals clean and legible at all times.
- Replace safety decals that are missing or have become illegible. See decal location figures that follow.
- Replaced parts must display the same decal(s) as the original part.
- Replacement safety decals are available **free of charge** from your distributor, dealer, or factory as applicable.

2.5. Decal Installation/Replacement



1. Decal area must be clean and dry, with a temperature above 50°F (10°C).
2. Decide on the exact position before you remove the backing paper.
3. Align the decal over the specified area and carefully press the small portion with the exposed sticky backing in place.
4. Slowly peel back the remaining paper and carefully smooth the remaining portion of the decal in place.
5. Small air pockets can be pierced with a pin and smoothed out using the decal backing paper.

2.6. Safety Decal Locations and Details

Replicas of the safety decals that are attached to the catwalk and their messages are shown in the figure(s) that follow. Safe operation and use of the catwalk requires that you familiarize yourself with the various safety decals and the areas or particular functions that the decals apply to, as well as the safety precautions that must be taken to avoid serious injury, death, or damage.

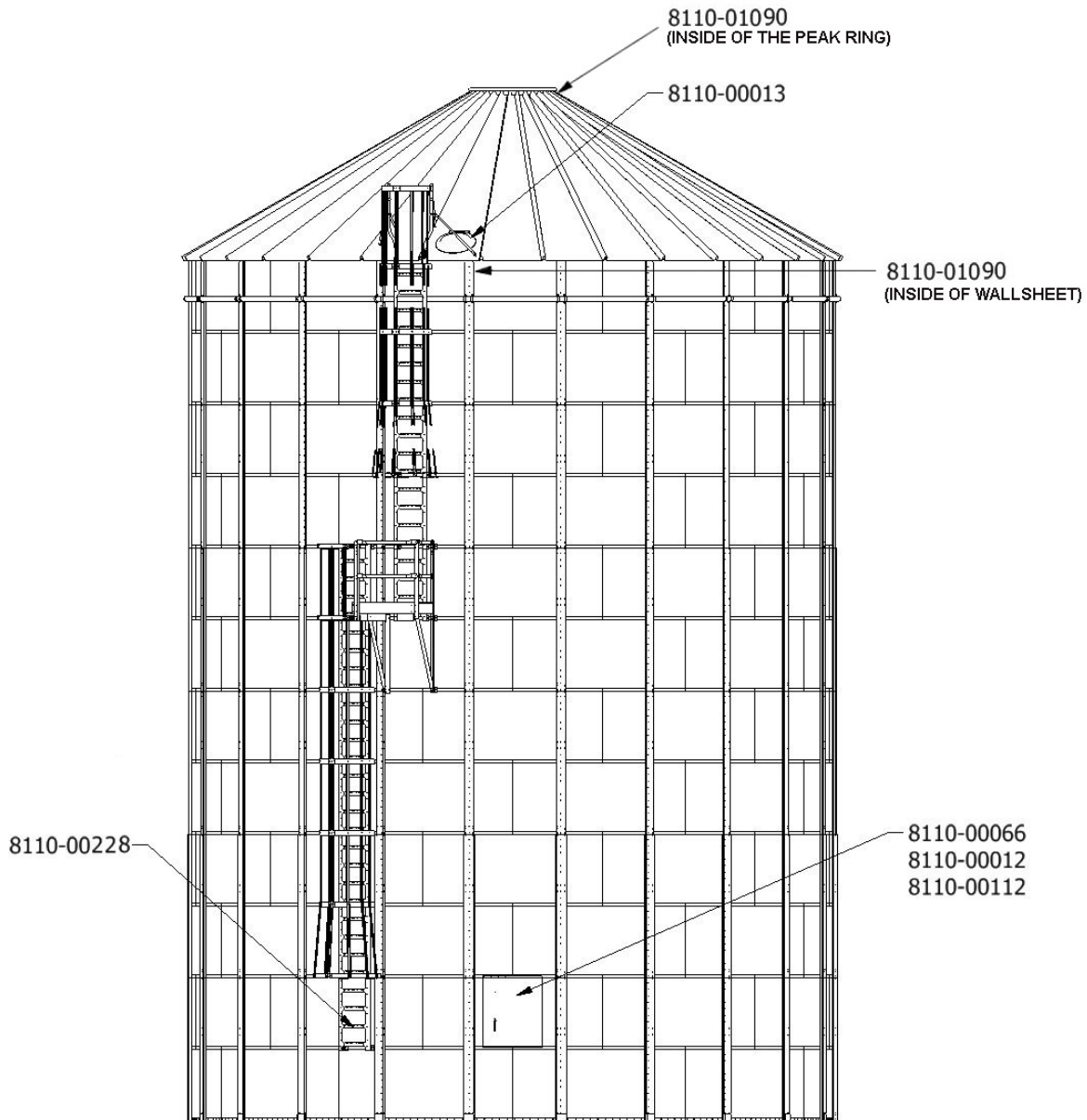
Figure 1. Safety Decals







 WARNING	
	
SAFETY INSTRUCTIONS	
<ul style="list-style-type: none"> • Read operator’s manual and all safety decals before assembling, using, or servicing bin. • Close/latch all access doors when not in use. • Do not alter or modify bin structure. • Replace any damaged components only with factory made components. • This bin should only be used to store free flowing, granular material, unless specifically designed and marked otherwise. • When filling, use top filler cap and direct material to center of bin. • Do not over-fill bin. Material should not be in contact with or place pressure on roof sheets. 	

Part Number: 8110–00012

 WARNING	
	
ENTRAPMENT HAZARD	
<p>Never enter the bin when loading or unloading grain.</p> <p>If you must enter the bin:</p> <ol style="list-style-type: none"> 1. Shut off and lock out all power. 2. Use a lifeline, safety harness, and have an observer outside before entering the bin. 3. Wear proper breathing equipment or a respirator. 4. Avoid the center of the bin. <p>Failure to heed these warnings could result in serious injury or death.</p>	

Part Number: 8110–00013

 WARNING		
		
Rotating flighting could kill or dismember.	Flowing material could trap and suffocate.	Crusted material could collapse and suffocate.
Keep clear of all augers. DO NOT ENTER this bin!		
<p>If you must enter the bin:</p> <ol style="list-style-type: none"> 1. Shut off and lock out all power. 2. Use a safety harness and safety line. 3. Station another person outside the bin. 4. Avoid the center of the bin. 5. Wear proper breathing equipment or respirator. <p>Failure to heed these warnings could result in serious injury or death.</p>		

Part Number: 8110–00112

WARNING



FALLING HAZARD

To prevent serious injury or death:

- Do not climb ladder if damaged, wet, icy, greasy, or slippery.
- Maintain good balance by having at least three points of contact at all times. Face the ladder while climbing.
- Safe working load is 350 lb (160 kg). Do not overload.
- Do not carry items while climbing.

Part Number: 8110-00228

NOTICE

When equipped with aeration system, to prevent roof and/or bin damage:

- Use a minimum 1 square foot (0.1m²) opening for each 1000ft³/min (30m³/min) of air.
- Ensure all roof vents are open and unobstructed.
- Discontinue use of aeration fan if roof vents become obstructed with ice.

Part Number: 8110-00066



**FALL RESTRAINT
ANCHOR POINT
MAX WORKING LOAD:
1,000 lb [453 kg]**

SEE MANUFACTURER ROOF MANUAL FOR
DETAILED INSTRUCTIONS REGARDING
ANCHOR POINT LOCATIONS

Part Number: 8110-01090

3. Before You Begin

3.1. Bin Design and Capacity

Standard Westeel Grain Bins are designed for:

1. Non-corrosive free-flowing materials up to 55 lbs/ft³ (880 kg/m³) average compacted bulk density.
2. Maximum horizontal wind pressure based on 94 mph (151 km/h) as per NBCC 2015 and 105 mph (169 km/h) as per ASCE 7-16.
3. Zero seismic activity.

Note

Seismic resistance in grain bins varies with height and diameter. Many standard designs have significant seismic capabilities. Designs can be reviewed and/or modified to reflect local seismic requirements.

4. Roof loading capabilities vary with diameter, peak load and snow load.
 - a. Peak Loads – standard peak loads follow. **Upgrades are available.**

Table 1. Peak Loads for Various Roofs

Size	Type of Roof	Load (lbs)	Load (kg)
15' to 24'	non-structural	4000 lbs	1814 kg
27' to 48'	non-structural	5000 lbs	2268 kg
51' & 54'	non-structural	8000 lbs	3629 kg
48' to 108'	structural	20,000 lbs	9072 kg

- b. Roof Snow Loads (RSL) – at the above stated standard peak loads, standard RSLs vary with diameter and range from 16 psf (78 kg/m²) to 45 psf (220 kg/m²). **Upgrades are available.**

Note

The correlation between ground snow load (GSL) and roof snow load (RSL) for grain bin designs vary with jurisdictions. In the US $GSL = 2 \times RSL$. In Europe $GSL = 1.25 \times RSL$. In Canada the correlation between GSL and RSL varies and is site specific.

- c. For maximum roof snow load capacities for various sizes and types of roofs, refer to the Roof Design Capacities sections that follow.

3.1.1 Roof Design Capacities for Non-Structural Roofs

Table 2. Maximum Roof Snow Load at STANDARD Peak Load

Bin Series	Std Peak Load	Standard Roof		Plus Upgrade 1		Plus Upgrade 2	
	lbs (kN)	psf	kPa	psf	kPa	psf	kPa
15	4000 (17.8)	45	2.15	n/a		n/a	
16		45	2.15				
18		45	2.15				
21		30	1.44	49	2.35		
24		21	1.01	40	1.92		
27		24	1.15	39	1.87		
30	5000 (22.2)	20	0.96	32	1.53	40	1.92
33		23	1.10	33	1.58	44	2.11
36		24	1.15	30	1.44	38	1.82
39		22	1.05	27	1.29	36	1.72
42		19	0.91	24	1.15	34	1.63
45		16	0.77	23	1.10	32	1.53
48		21	1.01	26	1.24	33	1.58
51		8000 (35.6)	20	0.96	28	1.34	n/a
54	17		0.81	27	1.29		

Table 3. Maximum Roof Snow Load at UPGRADED Peak Load

Bin Series	Upgraded Peak Load	Standard Roof		Plus Upgrade 1		Plus Upgrade 2			
	lbs (kN)	psf	kPa	psf	kPa	psf	kPa		
15	8000 (35.6)	29	1.39	n/a		n/a			
16		29	1.39						
18		29	1.39						
21		24	1.15	40	1.92				
24		17	0.81	27	1.29				
27	10000 (44.5)	19	0.91	28	1.34	n/a			
30		15	0.72	24	1.15			33	1.58
33		18	0.86	24	1.15			36	1.72
36		18	0.86	23	1.10			31	1.48
39		16	0.77	21	1.01			30	1.44
42		14	0.67	19	0.91			27	1.29
45		13	0.62	18	0.86			25	1.20
48*		16	0.77	21	1.01			26	1.24
51*	12000 (53.4)	14	0.67	21	1.01	n/a			
54*		13	0.62	20	0.96				

Note

1. Standard roofs are adequate for many applications but additional capacity is available when optional upgrade packages are used.
2. Upgrade packages include roof stiffening rings and/or rib supports.
3. For peak load between standard and upgrade limits, a straight line interpolation can be used to determine maximum roof snow load.
4. *Structural roofs for 48' – 54' with rafters are available to support peak ring loads greater than loads on [Table 3](#).
5. Higher level upgrade kits include all components from lower level kit; only one upgrade kit needs to be ordered for any given bin.

3.1.2 Roof Design Capacities for Structural Roofs

Table 4. Maximum Roof Snow Load at STANDARD Peak Loads

Bin Series	Std Peak Load	Standard Roof	
	lbs (kN)	psf	kPa
48	20000 (89.0)	39	1.87
51		39	1.87
54		39	1.87
60		39	1.87
66		38	1.82
72		38	1.82
75		37	1.77
78		37	1.77
84		37	1.77
90		37	1.77
96		37	1.77
102		32	1.53
105		32	1.53
108		32	1.53

Table 5. Maximum Roof Snow Load at UPGRADED Peak Loads

Bin Series	Upgraded Peak Load	Standard Roof	
	lbs (kN)	psf	kPa
48	60000 (266.9)	38	1.82
51		38	1.82
54		38	1.82
60		38	1.82
66		37	1.77
72		37	1.77
75		36	1.72
78		36	1.72
84		36	1.72
90		34	1.63
96		34	1.63
102		31	1.48
105		31	1.48
108		31	1.48

Note

Standard capacities are provided. Additional capacity is available with optional upgrades.

3.1.3 Roof Snow Load vs. Ground Snow Load

The Roof Design Capacity tables reflect roof snow load (RSL) values. These are design values. Often, comparisons are made to ground snow values (GSL). These are not the same. The conversion from GSL to RSL varies between jurisdictions and is governed by building codes:

- In the United States, for grain bins, $GSL = RSL \times 2$
- In Europe, for grain bins, $GSL = RSL \times 1.25$

- In Canada, for grain bins, the GSL/RSL conversion varies with every location across the country. However, for comparison purposes, the US conversion can be used as an approximation.

Therefore, when comparing against competitive GSL values in the US, double the above values. When comparing against competitive GSL values in Canada, double the above values for a reasonably close approximation.

3.2. Guidelines for Supporting Catwalks and other External Loads on Westeel

Frequently catwalk and related equipment loads are supported on grain bins. Such connections are commonly made into the grain bin stiffeners and across the peak. A grain bin is a thin shell structure primarily designed to withstand the internal uniformly distributed loads inherent with the stored bulk material inside of the bin. Special considerations must be given to the manner in which external loads are supported. Westeel has developed products which are compatible with these requirements and considerations. If a third party solution is provided, the provider assumes full responsibility of the structure, its load distribution, and the manner in which it is connected to the grain bin. The following guidelines must form part of the third party design considerations.

Connection to Stiffeners

1. The available catwalk support stiffeners in Westeel stiffened bins are for 10,000 lb incremental catwalk loads and 20,000 lb incremental catwalk loads per upgraded stiffener. The actual loads subjected to a single stiffener by the mating catwalk support shall not exceed these maximum capacities.
2. Westeel recommends that the vertical load transfer between the catwalk supports and the stiffener occur over a minimum distance of 66" for 10,000 lb loads and 120" for 20,000 lb loads. Adequate connection strength must be provided.
3. The catwalk support stiffener in Westeel bins are designed to provide vertical load support only. Any lateral loads subjected to the grain bin must be negligible.
4. There is a restriction of 2 upgraded catwalk support stiffeners per bin location. Therefore, the maximum supported load at the grain bin eave is 20,000 lbs (for two 10,000 lb upgrades) and 40,000 lbs (for two 20,000 lb upgrades). This can be repeated on the opposing side of the bin at a second location. Deviation from this must be approved by Westeel Engineering.

Connection to Peak Rings

1. The allowable vertical peak load to any Westeel bin roof is restricted to its published rated capacity. The load must be centered and evenly distributed into the peak ring. Any off-centre load and/or improper load distribution may cause roof failure.
2. A Westeel structural roof requires the peak support loads to be transferred directly into the compression ring/roof rafter system. This is accomplished with peak load support brackets that are included with the structural roof. They must be installed as shown in the structural roof manual, connecting the peak support structure to the compression ring. They are required even if a non-Westeel peak support structure is used. A non-Westeel peak support structure needs to be designed to be able to connect with the brackets. The required bolt pattern is shown in the structured roof manual.
3. A Westeel non-structural roof that is supporting a catwalk requires six clips to be installed in order to attach the flat cap to the peak ring. These clips are available from Westeel.

3.3. Foundation Design and Loads

The foundations for the stiffened bin models are based on 4000 lbs. per sq. ft. (192 kPa) soil bearing capacity. All foundation designs use 3000 lbs. per sq. in. (21 MPa) ultimate compressive strength (after 28 days) for concrete and 43,500 lbs. per sq. in. (300 MPa) re-bar. The foundation designs included in this manual are suggestions only, and will vary according to local soil conditions. Westeel will not assume any liability for results arising from their use.

Important

Foundation should be uniform and level. Level should not vary by more than ¼" over a span of four feet under the bottom ring angle. Any variance from level must be shimmed under upright base assembly. If being utilized to support a full floor aeration system, this levelness requirement should extend across the complete floor area.

3.4. Site and Assembly

Unless otherwise specifically provided in writing, Westeel does not take responsibility for any defects or damages to any property, or injury to any persons, arising from or related to any site or assembly considerations, including but not limited to:

- Bin location and bin siting
- Soil conditions and corresponding foundation requirements (note that the examples provided in manuals are for specifically stated soil conditions)
- Bin assembly (Westeel recommends the use of qualified bin installers; contact Westeel Grand Island for information on installers in your area)
- Field modifications or equipment additions that affect the bin structure
- Interconnections with neighboring structures
- Compliance with all applicable safety standards, including but not limited to fall restraint systems (ladders or other systems). Local safety authorities should be contacted as standards vary between jurisdictions.

3.5. Methods of Installation

The recommendations for assembling and installing Westeel grain bins must be closely followed to achieve the full strength of the bin and to achieve adequate weather sealing. The product warranty is void if:

1. Wall sheets and/or uprights not specified for a given tier are used.
2. Foundations are found to be inadequate or out-of-level.
3. Anchor bolts (cast-in-place, drill-in, chemical type or other) are found to be inadequate.
4. Off-center loading or unloading is used. (This does not apply to the use of approved side unloading systems.)
5. Materials stored are not free-flowing or have a compacted bulk density greater than 55 lbs/ft³ (880 kg/m³).

If using bin jacks during assembly, always lift on an upright. Choose a hoist with a adequate capacity for the expected empty bin deadload. Make sure the rated capacity of the hoist is not exceeded.

3.6. Critical Assembly Requirements

To ensure a successful, safe and reliable outcome you must comply with the following assembly techniques and practices:

1. Comply with all local code and jurisdictional requirements applicable to your catwalk installation.
2. Design and build foundations with the necessary strength for the loads they must support, and for local soil conditions. Westeel foundation guidelines are based on specific stated conditions and may not be applicable to local conditions.
3. Your foundation must provide uniform and level support to the structure being supported. Surface imperfections causing gapping must be remedied. This may involve, but not be limited to a) grouting under the bottom ring of a non-stiffened bin or tank, and b) shimming under the uprights of a stiffened bin or tank, or under the legs of a hopper.
4. Make sure that the proper hardware is utilized for all bolted connections. If a shortage occurs, do not substitute. Take the necessary steps to obtain the proper hardware. Make sure nuts are tightened to the required torque values as specified in the appropriate assembly manual.
5. Comply with all assembly instructions provided in the appropriate assembly manual to make sure your whole catwalk is constructed safely. **Important: Do not deviate from the wall sheet and upright layouts provided.**
6. Before anchoring your structure to its foundation, make sure the structure is round. The maximum variation from perfect roundness is 3/4" on the radius. Locate anchor bolts toward the outside of the anchor bolt holes (away from the circle) to permit the incremental expansion that can occur with the initial filling.
7. When installing roof stiffening rings, if it is necessary to shorten the stiffening ring tubes, shorten them as little as possible. Initially the nuts on the expanders should be centered and as close together as possible. When tightening, share the amount of take-up between expanders such that the nuts remain centered, and the amount of engagement between all expanders on the same ring is equalized.
8. If extending an existing bin or tank, ensure that the foundation is adequate for the increased loads it must support.
9. If installing an existing bin on a hopper, make sure the bin is designed for a hopper application, and that the foundation is capable of withstanding the substantial point loads that the hopper legs apply. If uprights are present, make sure that they are supported.
10. Make sure that an integral end-to-end connection exists between all mating uprights. Successive uprights must not overlap.
11. Vertical tolerances between uprights and wall sheets are tight. This can be affected by “jacking” techniques, which can allow the tolerance to grow or shrink depending on the technique used. The gapping between successive uprights must be monitored to ensure that upright holes align with wall sheet holes.
12. If catwalks are being installed on the structure, upright catwalk upgrades are likely required. The upgraded stiffeners must be installed in the correct locations to support the intended catwalk loads. Also, the structure must be properly oriented to ensure the eventual correct alignment between the catwalks and the supporting uprights. Finally, the connectors that tie into the uprights and support the catwalks are best installed during assembly of the structure. See the catwalk assembly manual for additional details.

3.7. Product Storage

Rust on Galvanized Parts

1. White rust forms when moisture is allowed to collect on galvanized surfaces that have yet to develop the durable zinc oxide layer. This zinc oxide layer naturally occurs as the surface interacts with carbon dioxide, and is characterized over time by the dull grey appearance that weathered galvanized surfaces get.
2. Parts that are not well ventilated or well drained can collect water between surfaces and develop white rust.
3. White rust is not a structural concern if its development is stopped in the early stages. A light film or powdery residue can occur after a period of heavy rainfall or a short time of improper storage. If white rust has started to develop, separate parts and wipe off any moisture. Next, using a clean cloth, apply a thin layer of petroleum jelly or food-grade oil to the entire part.
4. If moisture is left on parts, this white rust can become more aggressive and turn into red rust. Red rust can cause degradation in the material and become a structural concern. Any parts that have red rust should be replaced immediately.

Storage Guidelines

- Keep all bundles dry before assembly of the bin.
- Start assembly as soon as possible.
- Do not lay bundles on the bare ground. Raise all bundles 6" to 8" off the ground on wood blocks or timbers. (See Detail A in [Figure 2 on page 17.](#))
- Store curved wall sheets ‘hump-up’. (See Detail A in [Figure 2 on page 17.](#))
- All other bundles material should be placed so that they are well sloped to promote good drainage. (See Detail B in [Figure 2 on page 17.](#))
- Roof sheets must be elevated at least 12" at the small end of the sheets. (See Detail B in [Figure 2 on page 17.](#))
- Temporary storage can be provided by erecting a simple framework supporting a waterproof tarp. (See Detail C in [Figure 2 on page 17.](#))
- All bin boxes, ladder boxes and hardware boxes should be stored inside. These are not waterproof, and will deteriorate in normal weather conditions, allowing moisture to contact the parts inside.

Figure 2. Product Storage

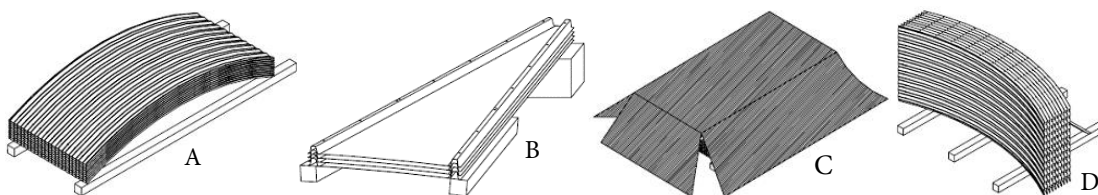

If Parts Become Wet

1. If parts become submerged or wet, the bundles should be opened as soon as possible, sheets or material separated and dried. Keep separated until assembly.

Brace parts properly so as to avoid damage or injury from material falling when in storage. (See Detail D in [Figure 2 on page 17.](#))

2. Any boxed parts that become wet should be dried and stored in a new box that is free of moisture.

3. In addition to wiping down wall sheets, a food-grade oil can also be applied with a clean, lint-free cloth. This will assist in preventing any further moisture from contacting the galvanizing on the steel. Due to safety concerns with installation and use, Westeel does not recommend the use of oil on other parts such as roof sheets and safety ladders.

3.8. Grain Bin Use

- Do not off-center unload a grain bin. It is imperative to unload from the center of the bin first, until as much grain as possible has been removed, and only then proceed to unload from the next closest unload gate to the center. Continue utilizing the unload gates in succession from the center towards the outside. Gate control mechanisms should be clearly marked and interconnected to prevent an external gate from being opened first.
- The only exception to center unloading is when a properly designed and installed side draw system is utilized. However, as bins tend to go out of round when employing side draws, the bin must be completely emptied before refilling.
- When unloading a bin with a mobile auger through a properly designed auger chute, the entry end of the auger should be pushed into the center of the bin before the auger is engaged. Slower rates of flow are preferable and should not exceed the capacity of an 8" auger.
- Ensure that the inner door panels of grain bin doors are completely closed and latched before filling the grain bin.
- Never enter a loaded grain bin for any reason. Grain can be a killer.

3.9. Important Notes

- Westeel does not provide a foundation design for this product, and is not liable for any damages or injuries related to inadequately designed or constructed foundations. Customers must contract professional services for all foundation design and construction work.
- In order to maintain your wall sheets in good condition separate sheets and allow air circulation between them. Store sheets in a dry place. Do not store sheets with sheet ends pointing upwards.
- To keep an even pressure on walls, the bin must always be unloaded from the center.
- Contact local power officials for minimum power line clearance.
- See [Section 3.6 – Critical Assembly Requirements on page 16](#) for mandatory siting and assembly requirements.
- Store only non-corrosive, free-flowing materials up to 55 lbs/ft³ (880 kg/m³) average compacted density in Westeel Grand Island bins.
- Tighten all bolts to the recommended torque settings.
- Do not locate grain bins close to high buildings, which might cause snow to fall onto or build up on the roof of the grain bin. Consider future expansion and allow space for loading and unloading of the bin. Your dealer and local government agricultural consultants can help you plan your storage system for maximum efficiency.

4. Preparation

4.1. Check Shipment

Unload the parts at the assembly site and compare the packing slip to the shipment. Ensure that all items have arrived and that none are damaged.

Report damaged parts or shortages immediately to your dealer. Your dealer will order replacement parts immediately to ensure that assembly will not be held up by missing parts. All parts will be charged for and credit will be issued by party at fault. No credit will be issued if freight bills are signed as received in good condition.

4.2. List of Tools and Equipment

Use quality tools and equipment. Use them safely, and correctly, for their intended use. Tools for this application should include:

Tools

- Electric or pneumatic (air) impact tools
- Power drill and drill bits
- Sockets (multiple 9/16" and 1/2" sockets recommended)
- Large-pocket carpenter pouch
- 8" (20 cm) metal punches (for aligning bolt holes)
- Step and extension ladders, construction grade
- 6-point wrenches (Imperial, box end)
- Metal-cutting saw suitable for cutting roof rings and wind rings
- Scaffolding
- Centre-post bin stand
- Crane and/or bin jacks

Minimum Recommended Safety Equipment

- A properly-stocked first-aid kit
- Eye, foot, head, and hand protection (safety glasses, steel-toed boots, hard hat, work gloves)
- Cable, chain, or rope to tie-off bin or jacks in case of wind
- Body harness and lifeline (for use where falling hazard exists)
- Ground fault interrupt protected electrical hook-ups

4.3. Order Optional Equipment

Optional equipment such as unloading augers, aeration equipment, anchor bolts, foundation sealant, external ladders, safety cage and platforms, etc., should all be on site and checked before assembly starts. Plan your installation in advance. For details, see assembly instruction supplied with optional equipment.

5. Assembly



Before continuing, ensure you have completely read and understood this manual's Safety section, in addition to the safety information in the section(s) below.

5.1. Assembly Safety

WARNING

- Do not take chances with safety. The components can be large, heavy, and hard to handle. Always use the proper tools, rated lifting equipment, and lifting points for the job.
- Carry out assembly in a large open area with a level surface.
- Always have two or more people assembling the catwalk.
- Make sure you have sufficient lighting for the work area.
- Tighten all fasteners according to their specifications. Do not replace or substitute bolts, nuts, or other hardware that is of lesser quality than the hardware supplied by the manufacturer.
- Stay away from overhead power lines and other obstructions during assembly. Contact with power lines can cause electrocution.
- Do not work in high winds.
- The equipment shall be installed in accordance with applicable local codes and regulations.

5.2. Structure of this Manual

The following sections of this manual provide information, guidelines, and instructions necessary to successfully assemble Westeel's Catwalk Systems. The Introduction provides a general description of catwalk modules, supports and accessories, followed by information on planning the assembly process. Each section thereafter begins with information about Standard Duty Catwalks with bar grating walkways, followed by information related to punched walkway models. Information on Heavy Duty Catwalks is included at the end of each section.

5.3. Introduction to Westeel's Catwalk Systems

The Westeel Catwalk System is a modular based system that utilizes a variety of modular components that can be mixed and matched to achieve most applications. Solutions have been developed for common applications to ensure that on-site modifications are kept to a minimum. Non-common applications may require some on site modifications, normally limited to shortening components and drilling holes.

5.3.1 Versions of the Westeel Catwalk System

Versions include:

- Two strength classifications – standard duty (SD) and heavy duty (HD). The SD version satisfies most typical installations. The HD version employs an integral trussed railing system and is reserved for those applications requiring greater loads and longer spans.

- Two walkway systems – Modules are available with a punched walkway or bar grating walkway. The punched walkway is a cost effective solution for many applications. The standard bar grating option features a serrated top walking surface and a galvanized finish. Other bar grating styles can be accommodated.
- Two conveyor widths – Base modules employ a 650 mm (25.6") wide walkway and a conveyor support section. The latter are available in a 700 mm (27.6") or 1 m (39.4") width.

5.3.2 Catwalk Modules

- Base catwalk sections are available in 3 m ($\approx 10'$), 6 m ($\approx 20'$), and 9 m ($\approx 30'$) long sections that can be joined together in any combination to provide a continuous catwalk
- Joiner modules are used to join adjacent sections together. A special joiner module is recommended when any length of catwalk exceeds 40 m ($\approx 130'$).
- End modules provide the means to close off the end of a catwalk.
- Variations – alternative systems are also being developed in response to demand
 - Walkway only modules in 3 m ($\approx 10'$), 6 m ($\approx 20'$), and 9 m ($\approx 30'$) long sections are 650 mm (25.6") wide
 - Double walkway modules in 3 m ($\approx 10'$), 6 m ($\approx 20'$), and 9 m ($\approx 30'$) long sections are 1300 mm (51.2") wide
 - A walkway + 1 m conveyor + walkway (WCW) module in 3 m ($\approx 10'$), 6 m ($\approx 20'$), and 9 m ($\approx 30'$) long sections (bar grating only)

5.3.3 Catwalk Supports

Catwalks are supported at the grain bin peaks, at the eaves of bins by goal posts and knee braces, by separate independent towers, or by tying into some other supporting structure.

- Peak Support modules are mounted integrally into the commercial flat grain bin caps, as well as into the underlying compression rings (structural roofs only). Standard duty peak supports are compatible with most loading scenarios; upgraded HD peak supports are used for heavier loads.
- Goal Post modules tie into the grain bin upright structure and span upwards from the eaves of the bin to support overhead catwalks. There are 44.5 kN (10,000 lb) versions and 89 kN (20,000 lb) versions. They can also be installed on adjacent uprights (single spacing) or on uprights spaced two apart (double spacing).
- When required, Knee Braces modules tie into the goal posts to reduce the unsupported span of overhead catwalks. There are two types:
 1. "A" knee brace modules, which bolt onto the bin side of the goal post and span up over the grain bin roof.
 2. "B" knee brace modules which bolt onto the non-grain bin side of the goal post and span up and away from the grain bin.

The timing (i.e. orientation) of the primary "Z" channel is an important consideration. Special attention should be given to these considerations when reviewing the manual. The knee braces are also tied to the goal posts utilizing tubes of different lengths.

- Finally there are various inter-bin brace options to support goal posts on adjacent bins.

5.3.4 Catwalk Accessories

Various accessories complete the catwalk system.

- Service Platforms – a 3 m ($\approx 10'$) of walkway service platform provides an additional 650 mm (25.6") of walkway at strategic locations along the catwalk
- Service Platform Add On (bar grating only) – a separate 3 m ($\approx 10'$) walkway extension plugs in at almost any location along a catwalk providing an additional 650 mm (25.6") of walkway width
- Cross Catwalk Module – a 3 m ($\approx 10'$) catwalk module that intersects another catwalk at 90° permits the initiation of a cross catwalk. Once started the regular catwalk modules add on to complete the catwalk run
- Ladder Access (Peak) Module – Provides an access point to the catwalk at a grain bin peak location and includes a self-closing access door. This ties into existing roof stairs or roof ladder packages.
- Ladder Access (Goal Post) Module – TBD

5.3.5 Planning

The various catwalk modules and accessories can be mixed and matched to provide a cost effective catwalk system to meet a number of needs. The following should be kept in mind when planning a catwalk system:

- Catwalk designs are dependent on load versus span considerations, which are in turn dependent on a number of other factors. Consult Westeel's Application Engineering personnel for specific design support.
- Catwalks are routinely supported by goal post systems that tie into the upright structure of the bin, which are specially upgraded. This must be considered in the design of the bin, and the bin must be subsequently constructed to align the upgraded stiffeners with the goal post locations. The use of single upright spacing goal posts, versus double upright spacing goal posts, also affects the timing with respect to various elements. Be sure to consult specific site layouts.
- The connection of the goal posts to the bin uprights is made utilizing upright connectors, which are specific to bin diameter. They are available under a separate part number. Ideally these are installed as the bin is being constructed and therefore should be delivered with the bin.
- Grain bin roof upgrades may be required in order to support the increased peak loads inherent with an overhead catwalk.
- The end of a catwalk run may extend out over a peak or goal post location. This may be acceptable for a given application. However if a fixed length is required, any catwalk standard module can be cut to provide this length. Some field modifications are required. See detail provided in [Section 5.8 – End Modules on page 42](#).
- A thermal break is recommended for any catwalk length exceeding 40 m (130'). See detail provided in [Section 5.7 – Catwalk Joiner Module Assembly on page 34](#).
- The handrail system is an integral structural component of the HD system. Any break in the handrail to accommodate an accessory such as a service platform, a cross conveyor, a cross walk, an entry point, etc. should only occur at a point of vertical support (such as at a peak location, or over a goal post).
- A cross catwalk will intersect at the midpoint of a 3 m ($\approx 10'$) base catwalk section without the need to drill holes. The cross catwalk can also intersect any base catwalk section at any other location. However, some minor field modifications will be required. See detail provided in [Section 5.10 – Cross Catwalk Modules on page 56](#).
- A cross catwalk (or walkway) requires the 3 m ($\approx 10'$) cross catwalk module (or walkway module) at the intersection point with the primary catwalk. These intersections should be made at right angles.
- Catwalk modules can be assembled on the ground and craned into place. Insure the first catwalk section is long enough to bridge between two points of support. Installing the "Z" splice connectors on the receiving end of the first section creates a "pocket" to receive the next section, and so on. Subsequent sections must be long enough to reach subsequent points of vertical support.

5.4. Standard Duty Catwalk Section Assembly

Catwalks sections are available in 3 m (≈10'), 6 m (≈20') and 9 m (≈30') sections. The assembly of each is basically identical. The following illustrates the 3 m section. The assembly of the 6 m and 9 m sections follow the same assembly techniques with exceptions noted.

Note

All bolted connections are made using 3/8" x 1" bolts with adhesive strip applied and flanged nuts unless indicated or otherwise illustrated. See [Section 6.2 – Hardware Usage on page 98](#) for detail on connection hardware.

1. Support "Z" beams on a level surface as necessary along their length such that they are at least 150 mm (6") off of the ground to facilitate ease of assembly.

Note the orientation of the three beams varies from side to side. One must be flipped end to end with respect to the others. The opposing "Z" sections are on either side of the walkway section [Figure 3 on page 23](#). Also the top and bottom flange of the "Z" beams are not the same width. The wider flange is towards the top on all "Z" support beams.

Figure 3. Hat Section Cross Members & Diagonal Cross Members

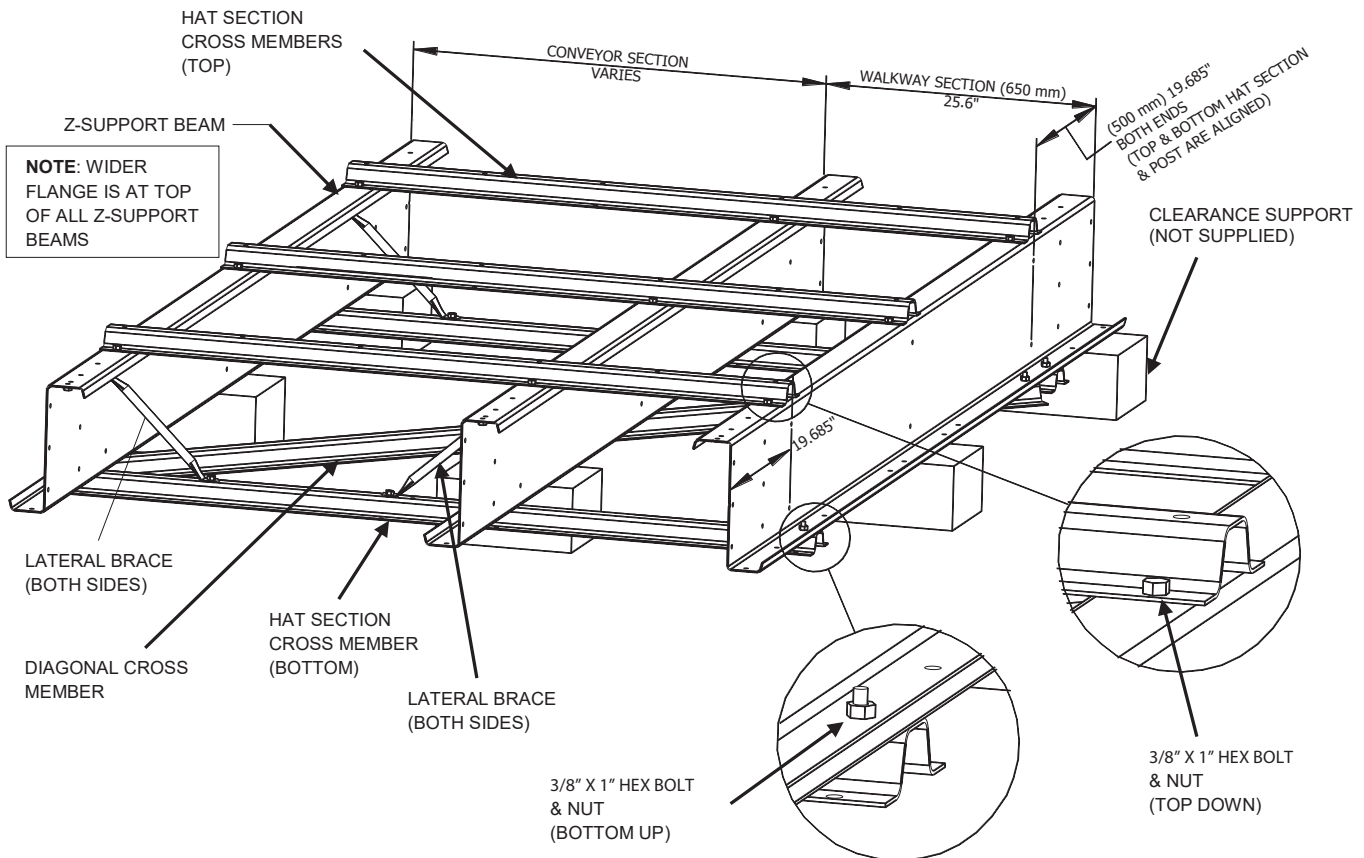

2. Bolt on the bottom hat section cross members and diagonal cross members as illustrated.

Do not tighten the nuts until the complete module has been assembled and squared with itself (see [Figure 3 on page 23](#)). Note that on 6 m and 9 m sections the pattern repeats 2 and 3 times respectively. If possible, alternate the positioning of the diagonal hat section cross members so they are not all angled in the same direction (see [Figure 4 on page 24](#)).

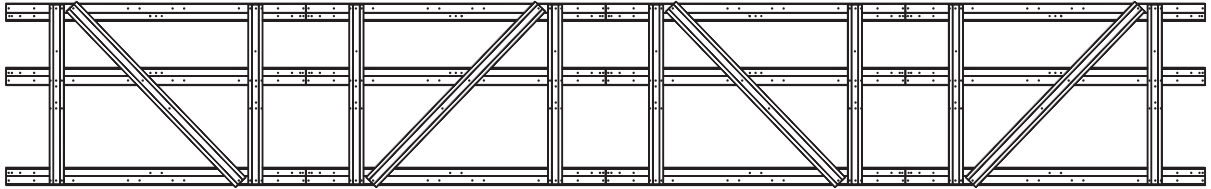
Figure 4. Hat Section Bottom View

VIEW FROM BOTTOM – RECOMMEND STAGGERING SLOPE OF DIAGONAL CROSS MEMBERS AS SHOWN

3. Bolt on the top hat section cross members as illustrated in [Figure 3 on page 23](#)

Be aware that when mating catwalk modules there is a top cross member that forms part of the joint connection (see [Section 5.7 – Catwalk Joiner Module Assembly on page 34](#)). This supports the ends of the punched walkways and bar grating, which are provided in 3 m sections. Therefore in 6 m and 9 m top catwalk sections, hat section cross members should also be positioned at 3 m increments to support the eventual joints between walkway sections.

Note

When final positioning of the catwalks occurs there may be interference between a top or bottom hat section, and some other feature on the installation such as a downspout. At these locations it is acceptable to cut the interfering hat section member between "Z" beams to facilitate fit-up.

4. Bolt on lateral braces between the "Z" beams and the bottom cross members (see [Figure 3 on page 23](#))

Note

For Heavy Duty Catwalk railing system see instructions at the end of this section.

5. For Standard Duty sections, bolt the vertical posts to the outside of the "Z" beams using 3/8" x 2" bolts and nuts at both bolt hole locations.

Vertical posts are spaced at 1 meter intervals [Figure 3 on page 23](#).

6. Assemble the top and mid rails as shown in [Figure 5 on page 25](#).

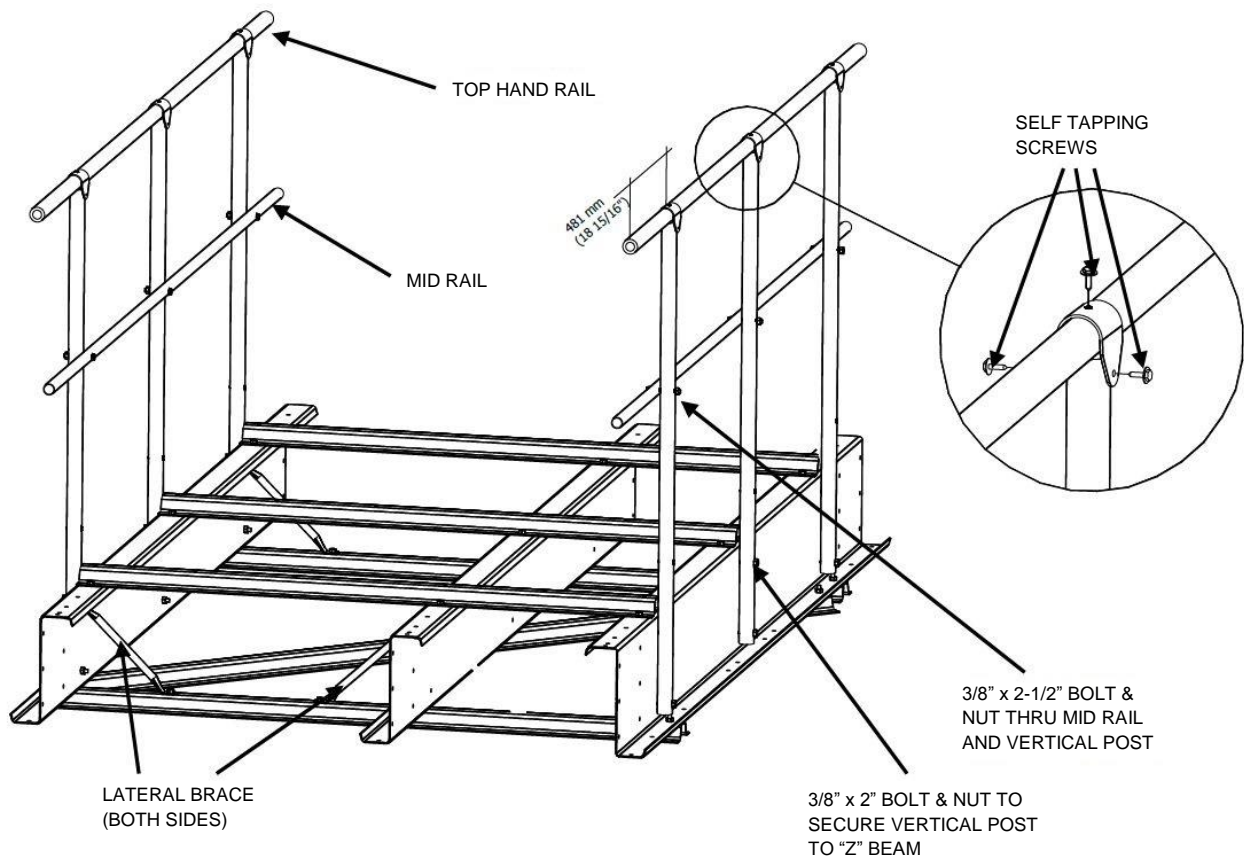
Figure 5. Assembling top hand rail and mid rails

- a. Bolt the mid-rail to the vertical posts using 3/8" x 2-1/2" bolts and nuts.
- b. Secure the hand rails to the top of the vertical posts using connector clips at all post locations.
- c. Secure with 3 self-drilling screws at all connector locations as illustrated.
- d. Center both rails within the catwalk section.
- e. Make sure the ends of the rails protrude to the same extent between catwalk sections so repositioning at a later time is not required.

The top handrail should protrude 481 mm (18 15/16") beyond the edges of the handrail connection brackets.

- f. For 6 m and 9 m sections, connect together the top and mid rail tubes within the section in the same manner as they are connected when mating sections meet.
- g. Use the short 150 mm (6") splice tubes to splice between mating handrails and mid rails.
- h. Insert one half of the splice tube into the end of one of the rail tubes and secure with a self-drilling screw.
- i. Position the second tube and secure.

Since the mating catwalk section fits onto this splice, try to be consistent in applying these splices (see [Section 5.7 – Catwalk Joiner Module Assembly on page 34](#))

7. Ensure the section is square with itself by measuring corner to corner at opposing corners. Make necessary adjustments and tighten all nuts and bolts.

8. Bolt on the grating option supplied with the catwalk. Leave the assembly of these components until all mating catwalk sections have been joined together and then lay the grating along the entire span. Note that there should be a top hat section cross member under all grating joints which occurs at 3 m increments. This naturally occurs between mating catwalk sections, but also incurs within the 6m and 9 m sections at 3 m increments. Make sure the grating supports are properly supported with top hat section cross members.
- a. Bar Grating and Toe Board Option (See [Figure 6 on page 26](#) and [Figure 7 on page 27](#)): The grating should be centered within the catwalk area and each end should rest on a hat section cross member. The toe boards are positioned on top of the grating along each side. The holes in the bottom toe board flange align with holes in the hat section cross members – use 3/8" x 2" standard hex bolts (w/o adhesive) and flanged nuts to secure. There are also holes in the toe board side flange that align with holes in the vertical posts – use 3/8" x 2" bolts and flanged nuts to secure. Toe boards are joined using toe board splices.

Figure 6. Bar Grating Walkway

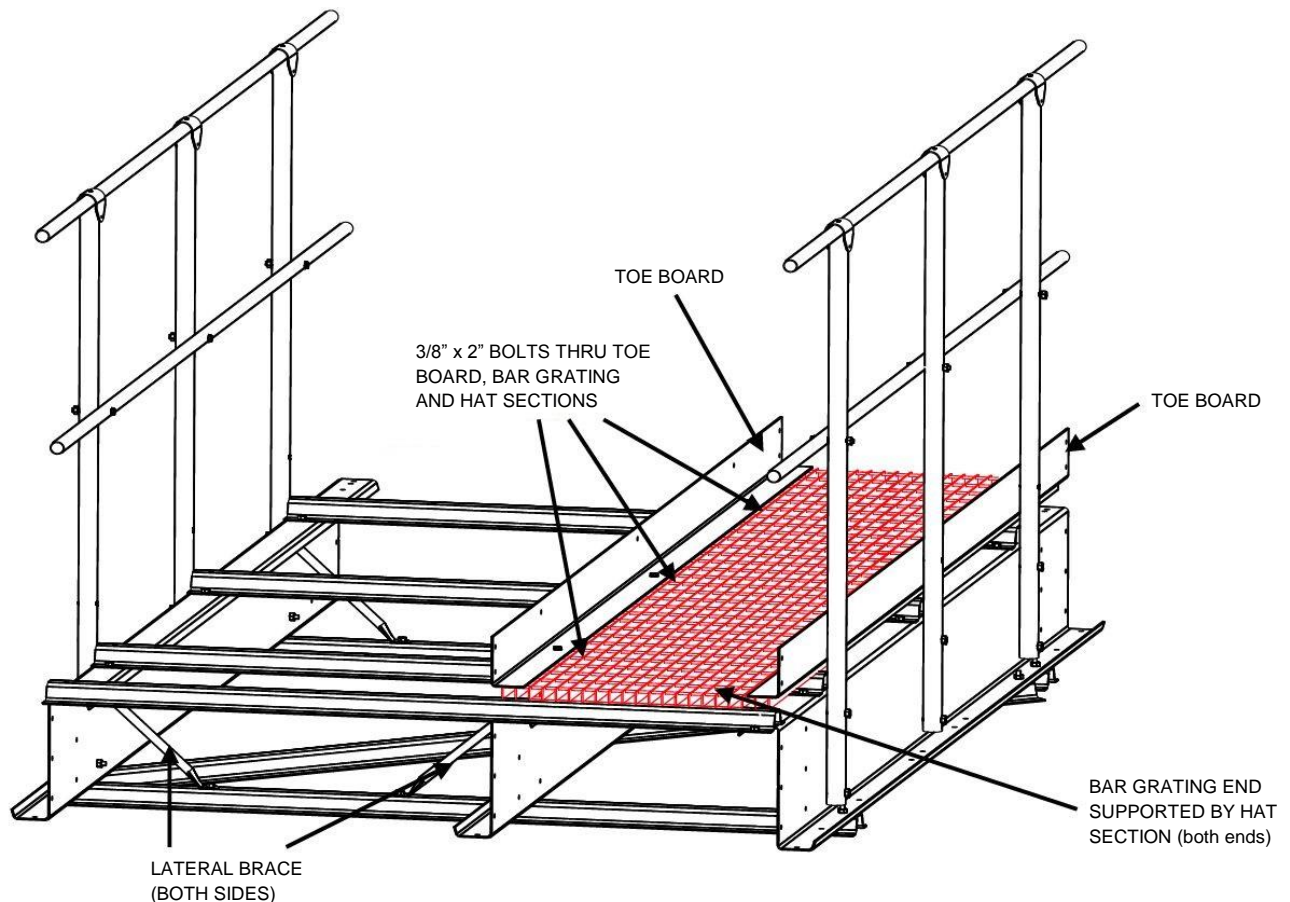
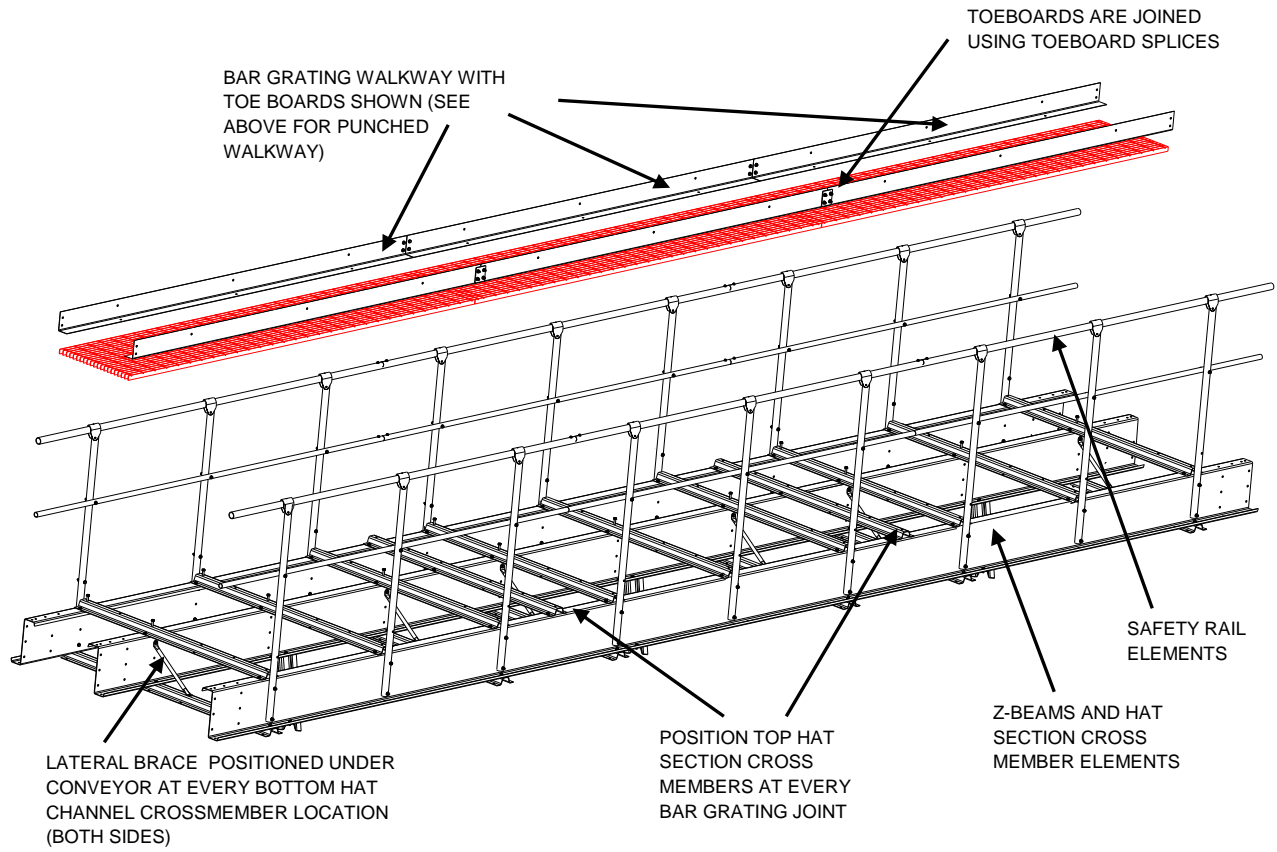

Figure 7. 9 m Bar Grating Walkway

- b. Punched Walkway Option (Figure 8 on page 28 and Figure 9 on page 28): The punched walkway includes the toe boards as part of the walkway configuration. The walkway should be centered within the catwalk area and each end should rest on a hat section cross member. The bolt holes in the bottom section of the walkway align with holes in the hat section cross members – use 3/8" x 1" standard hex bolts (w/o adhesive) and flanged nuts to secure. The holes in the toe board flanges align with holes in the vertical posts – use 3/8" x 2" bolts and flanged nuts to secure. Toe boards are joined using toe board splices.

Figure 8. Punched Walkway

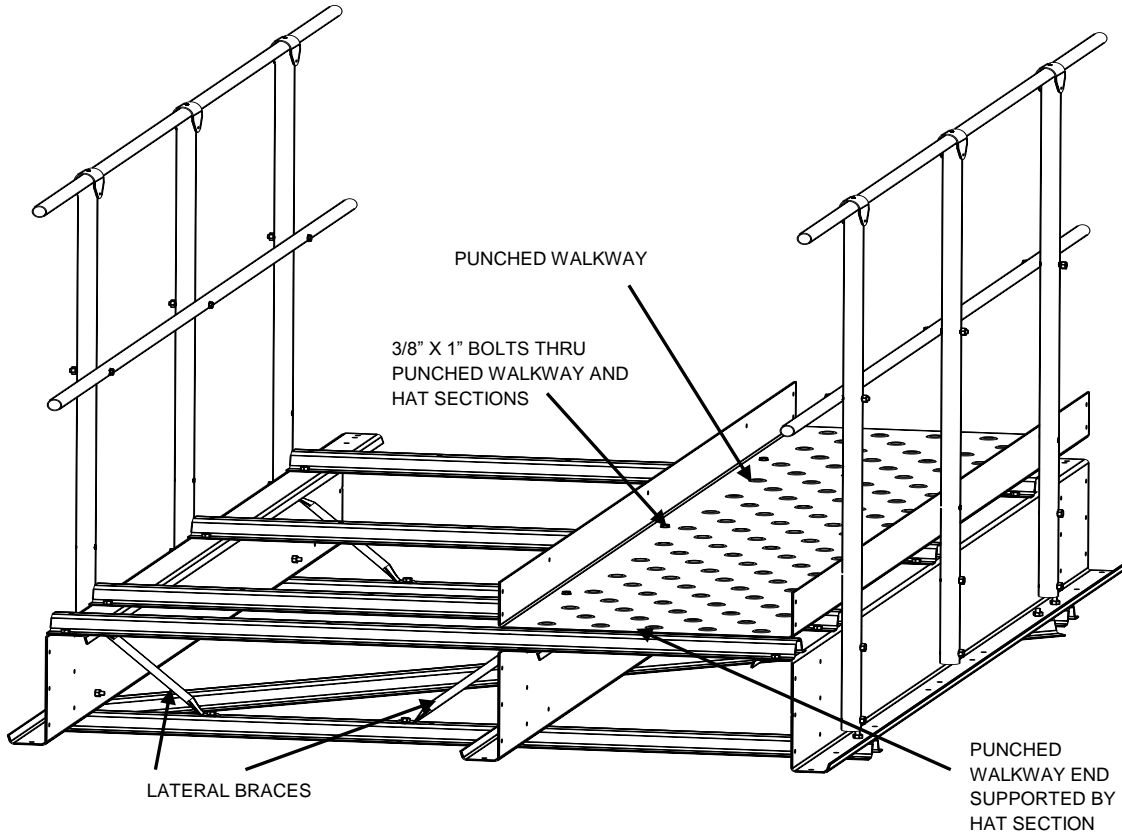
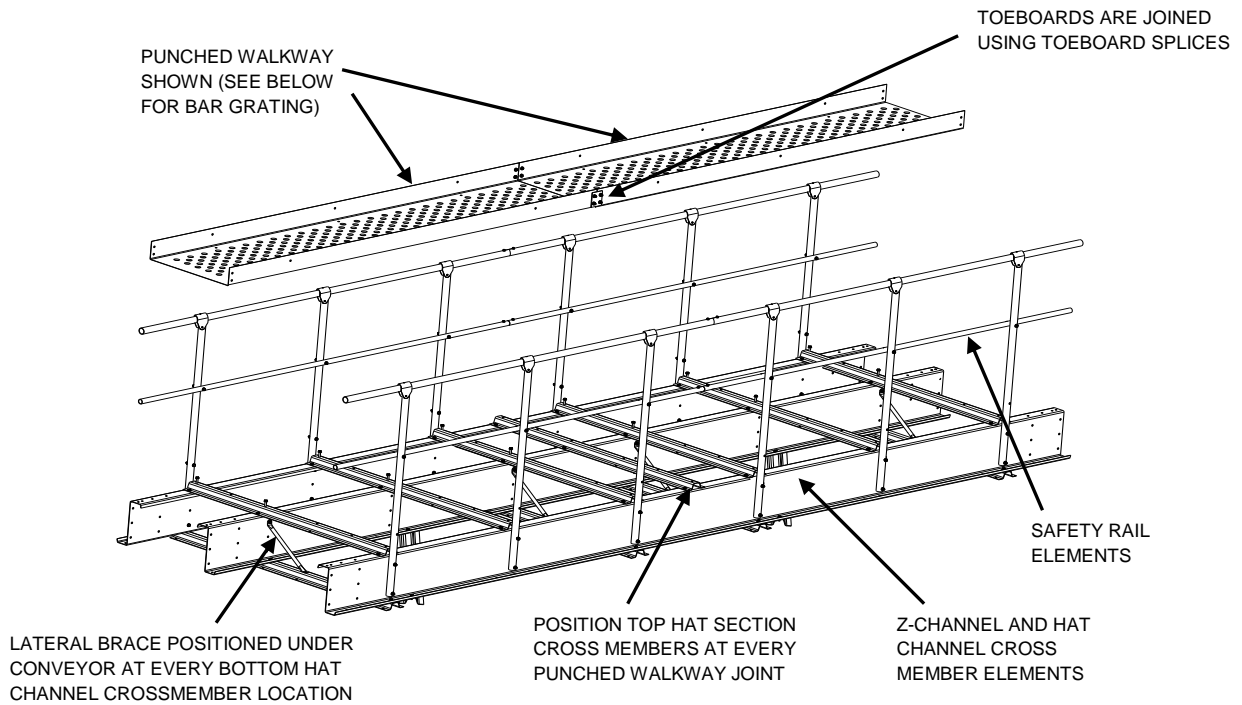

Figure 9. 6 m Punched Walkway



5.5. Heavy Duty Catwalk Section Assembly

1. Bolt the vertical posts to the outside of the Z-beams using 3/8" x 2" bolts and nuts.

There are 2 holes at the bottom of the vertical post tubes (see [Figure 10 on page 29](#)). The upper hole of these two is also used to secure the lower end of the diagonal tube brace.

Figure 10. Heavy Duty Catwalk Braces and Posts

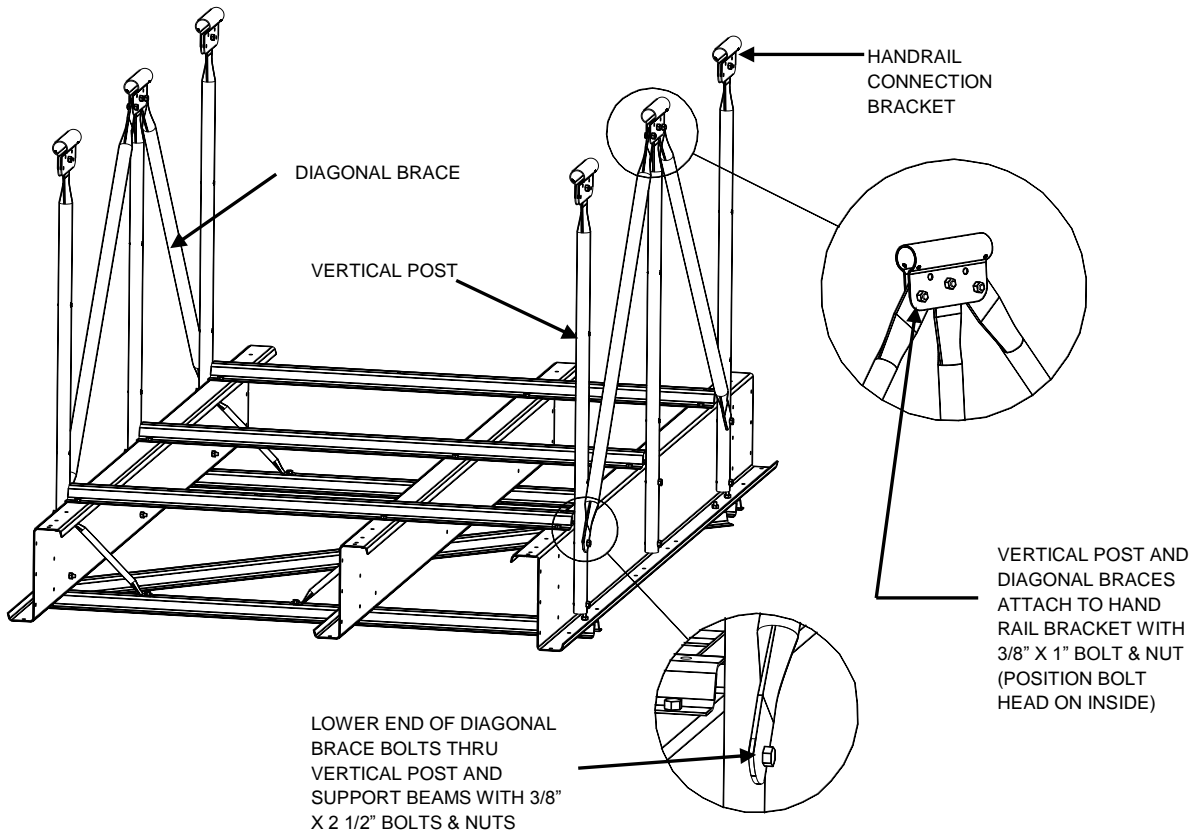

2. Make the connection at the lower bolt hole first, then position the diagonal tube brace over the second hole and make that connection.

Note that the diagonal braces are positioned on the outside surface of the vertical posts. The upper connections occur at the handrail connection brackets, which have holes punched to accommodate the flattened ends of both the vertical posts and the diagonal tube brace. Also, when mating catwalk sections are bolted together, there is a diagonal tube brace that forms part of the joint connection (see [Section on Section 5.7 – Catwalk Joiner Module Assembly on page 34](#)).

Note

The diagonal tube braces can be angled in either direction and still maintain structural strength. However, it is best practice to angle the diagonal tube braces in a consistent manner, as illustrated in [Section 5.5 – Heavy Duty Catwalk Section Assembly on page 29](#). Do not tighten the handrail connection bracket bolts until after the handrails are inserted and positioned.

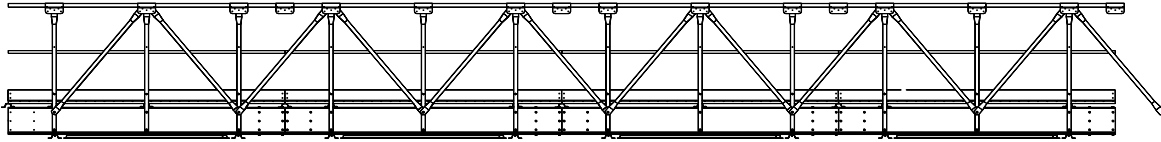
Figure 11. Heavy Duty Catwalk Section Side View

VIEW FROM SIDE – RECOMMENDED DIAGONAL TUBE BRACE CONFIGURATION

3. Assemble the top and mid rails as shown in [Figure 12 on page 30](#).

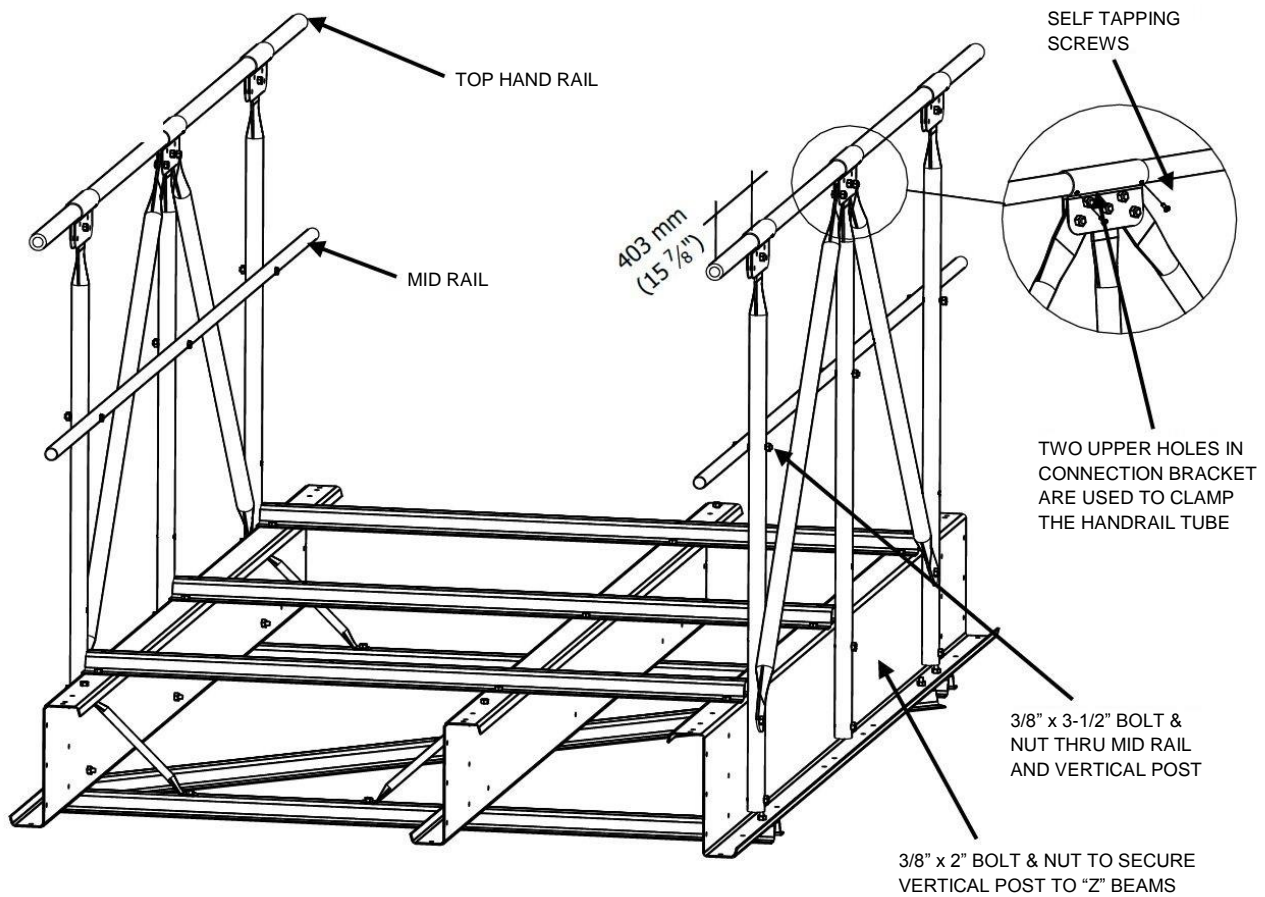
Figure 12. Heavy Duty Catwalk Top Hand Rail and Mid-Rails

- a. Center both rails within the catwalk section.
- b. Make sure the ends of the rails protrude to the same extent between catwalk sections so repositioning at a later time is not required.

The top handrail protrudes 403 mm (15 7/8") beyond the edges of the handrail connection brackets.

4. Use two additional bolts within the handrail connection bracket to clamp the tube in place.
All bolt heads should be positioned to the inside with nuts positioned to the outside.
5. Bolt the mid rails onto the vertical posts as illustrated using 3/8" x 3 1/2" bolts.

For 6 m and 9 m sections the top and mid rail tubes are connected together within the section in the same manner as they are connected when mating sections meet.

6. Use the short 152 mm (6") splice tubes to splice between mating mid rails.
7. Insert one half of the splice tube into the end of one of the mid rail tubes and secure with a self-drilling screw.

Since the mating catwalk section fits onto this splice, be consistent in applying these splices (see [Section 5.7 – Catwalk Joiner Module Assembly on page 34](#)). It may be advisable to leave the mid rails until after the mating catwalk sections have been connected.

Note

The mid rails can be bolted on after the sections have been joined together.

5.6. Base Module Variations

The following are variations to the base modules. The assembly procedure remains consistent with the information provided earlier. Exceptions are noted on the following exploded assemblies. Not all variations are available with all of the standard features.

5.6.1 Single Walkway

The walkways feature a 650 mm (25.6") wide walkway only. They are available in 3 m ($\approx 10'$), 6 m ($\approx 20'$) and 9 m ($\approx 30'$) sections in either a punched walkway or bar grating format. If utilized with standard catwalk sections as a cross walkway, the intersection with the regular catwalk should be made with 3 m walkway sections. Intersection with a Heavy Duty Catwalk should occur at or near a location providing vertical support such as at the peak supports or goal post support

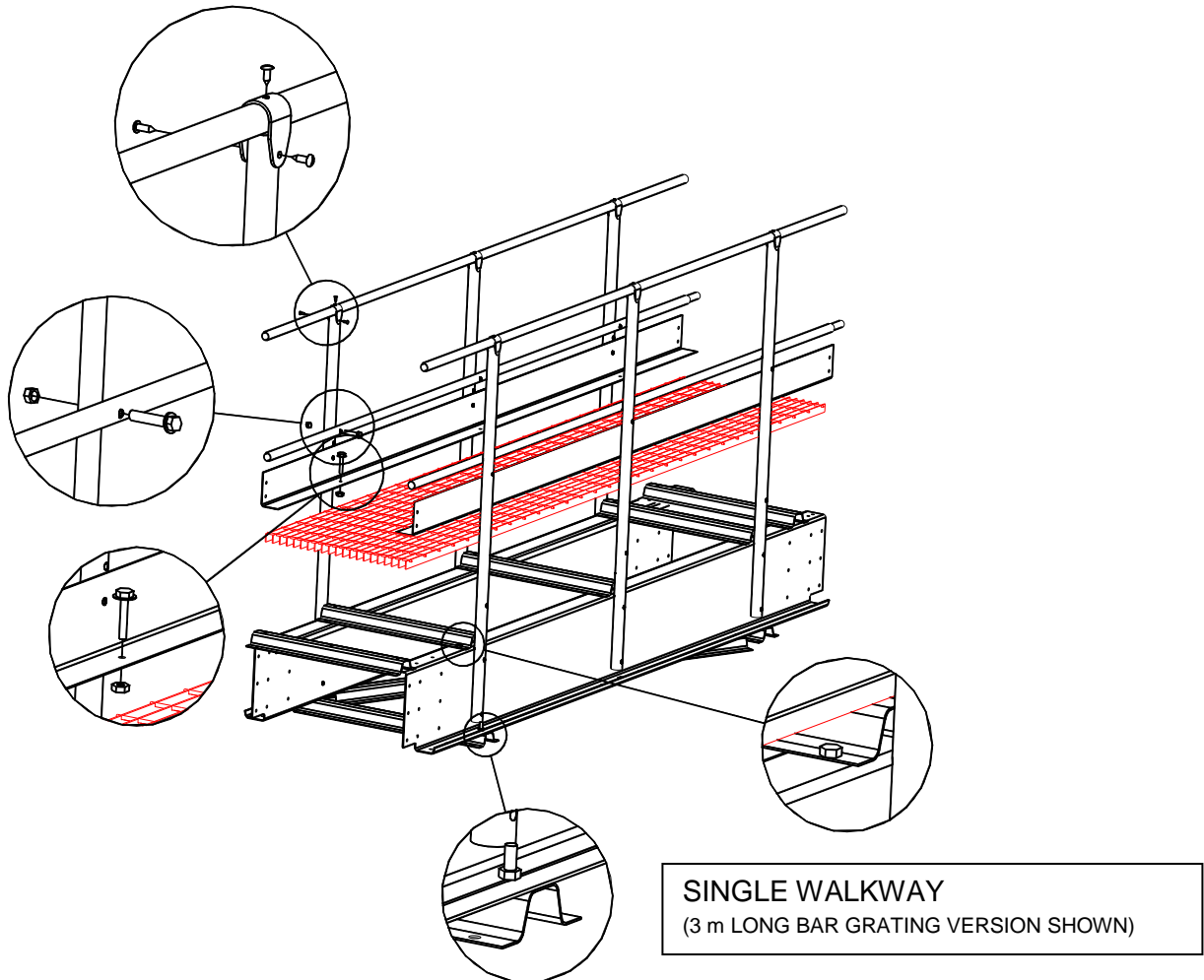
Figure 13. Single Walkway**Note**

Assembly procedures are consistent with those contained in the [Section 5.4 – Standard Duty Catwalk Section Assembly on page 23](#).

Note

For the Trussed Handrail version of the Single Walkway, assemble handrails as per information provided in the [Section 5.5 – Heavy Duty Catwalk Section Assembly on page 29](#).

5.6.2 Double Walkway

The double walkway features a 1300 mm (51.2") wide walkway. They are available in the same lengths as the single walkway and bar grating format only. Installation considerations remain consistent with the single walkway.

Figure 14.

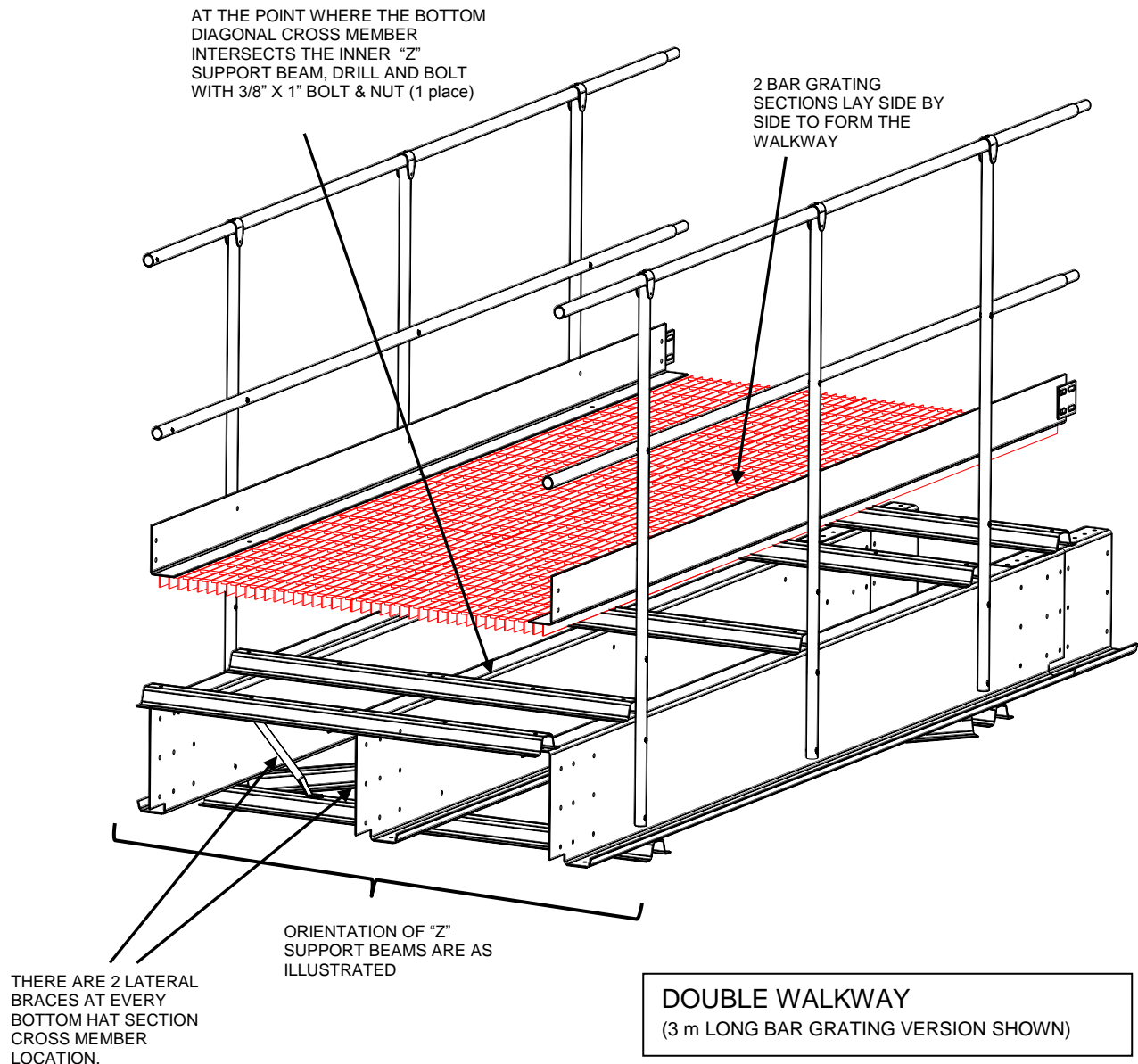

Note

Assembly procedures are consistent with those contained in the [Section 5.4 – Standard Duty Catwalk Section Assembly on page 23.](#)

Note

For the Trussed Handrail version of the Double Walkway, assemble handrails as per information provided in the [Section 5.5 – Heavy Duty Catwalk Section Assembly on page 29.](#)

5.6.3 Walkway/Conveyor/Walkway (WCW)

The WCW features two 650 mm (25.6") wide walkways on either side of a 1 m (39.4") wide conveyor support section. They are available in 3 m (≈10'), 6 m (≈20') and 9 m (≈30') sections in bar grating format only.

Figure 15. Walkway/Conveyor/Walkway

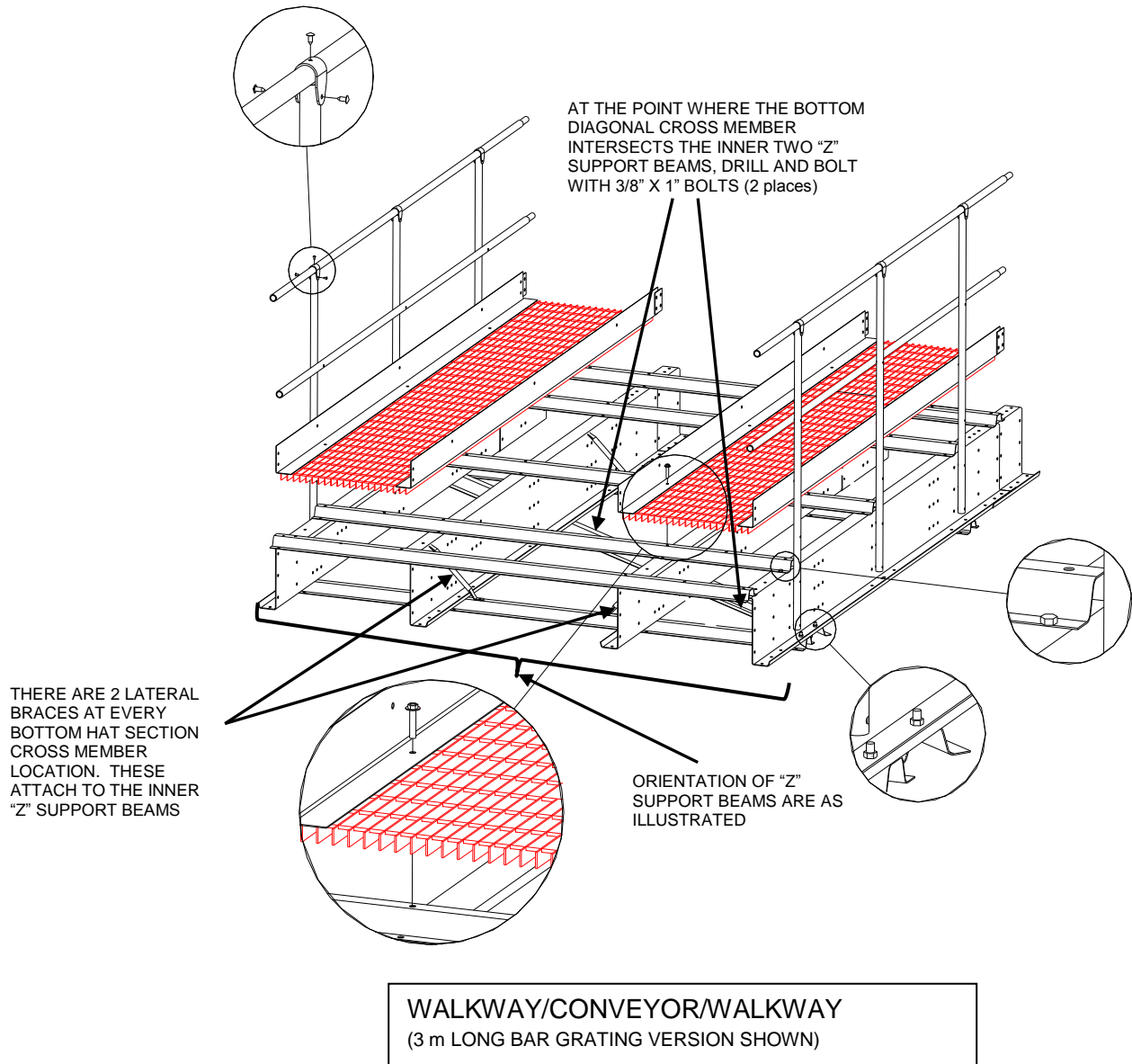

Note

Assembly procedures are consistent with those contained in the [Section 5.4 – Standard Duty Catwalk Section Assembly on page 23](#).

Note

For the Trussed Handrail version of the Walkway-Conveyor-Walkway, assemble handrails as per information provided in the [Section 5.5 – Heavy Duty Catwalk Section Assembly on page 29](#).

5.7. Catwalk Joiner Module Assembly

Once the individual modules are assembled, they are joined together. There is a Catwalk Joiner Module provided for every catwalk joint. Many of the connector pieces can be installed during the assembly of the base modules, however care must be taken to avoid placing connector pieces on both ends of mating modules,

otherwise interference of similar parts will occur. Instruction is provided for both the normal joints and the special thermal joint. Special considerations for the Heavy Duty Catwalk are included at the end of each respective section.

5.7.1 Standard Duty Joiner Modules

The principle structural connection between mating catwalk modules is facilitated with the use of Z-section beam splices at every Z-beam connection location.

1. Invert the beam splices such that the narrow flange of the section is on top and insert into the ends of the Z-beams on one of the mating catwalk modules.
2. Bolt in place at every Z- beam location using 3/8" x 1" bolts.
3. Position the second catwalk module on the protruding beam splices and bolt into place.

Note

This arrangement is particularly useful when slinging mating modules together in elevated locations as the splice forms a pocket that the mating modules drops down onto.

Figure 16. Splicing a "Z" beam

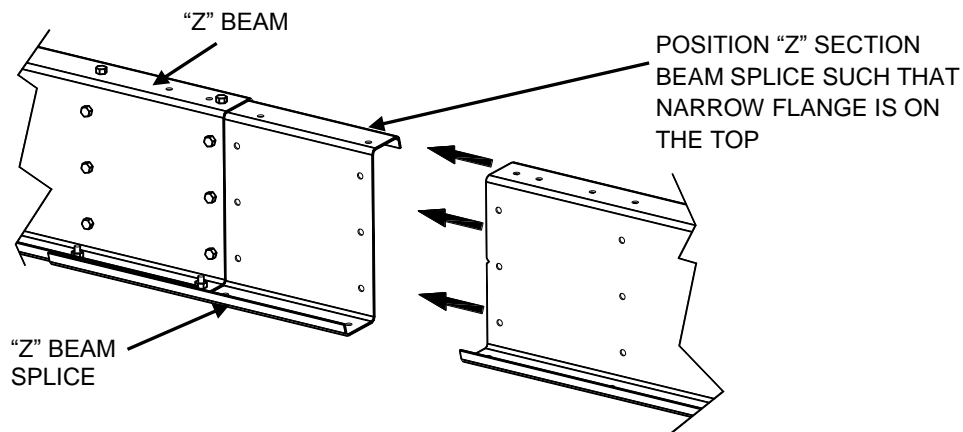

4. Join the mating top handrail and mid rail tubes together using short 152 mm (6") splice tubes.
5. Insert one half of the short mid-rail splice tube into the end of one of the mid-rail tubes and secure with a self-drilling screw.
6. Position the mating mid-rail tube over the splice tube and secure this end as well.

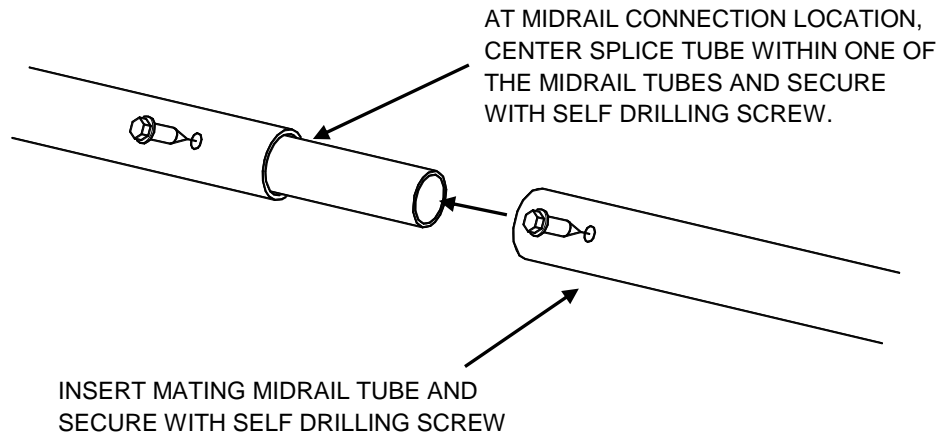
Figure 17. Joining top and mid rail tubes**Note**

For Heavy Duty Catwalk railing systems see instructions at the end of this section.

7. Every joint location has a top hat section cross member. Bolt on the top hat section cross member as described in Standard Duty Catwalk Section Assembly, [Step 3 on page 24](#).

The ends of the punched walkway or bar grating walkway will eventually be supported at this location.

Figure 18. Top Hat Section Cross Member

TOP HAT SECTION CROSSMEMBER
POSITIONED OVER EVERY CATWALK
MODULE JOINING LOCATION

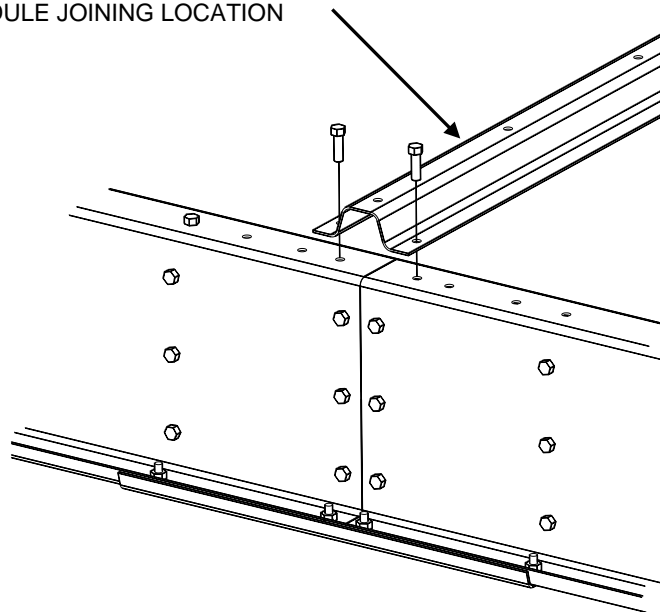
**8. Options:**

- a. **Bar Grating and Toe Board Option:** Bolt on toe boards and grating if not completed earlier as described in Standard Duty Catwalk Section Assembly, [Step 8 on page 26](#).

All grating joints should rest on an underlying hat section cross member. There is a toe board splice to join mating toe boards. Position bolt heads to the inside. The bar grating option is illustrated below.

Figure 19. Bar Grating and Toe Board Option

BOLT ON THE TOE BOARD SPLICE AT EVERY TOE BOARD JOINT. PLACE BOLT HEADS ON THE INSIDE AND NUTS ON THE OUTSIDE.

MATING GRATING SECTIONS BUTT TOGETHER AND ARE SUPPORTED BY THE UNDERLYING TOP HAT SECTION CROSS MEMBER

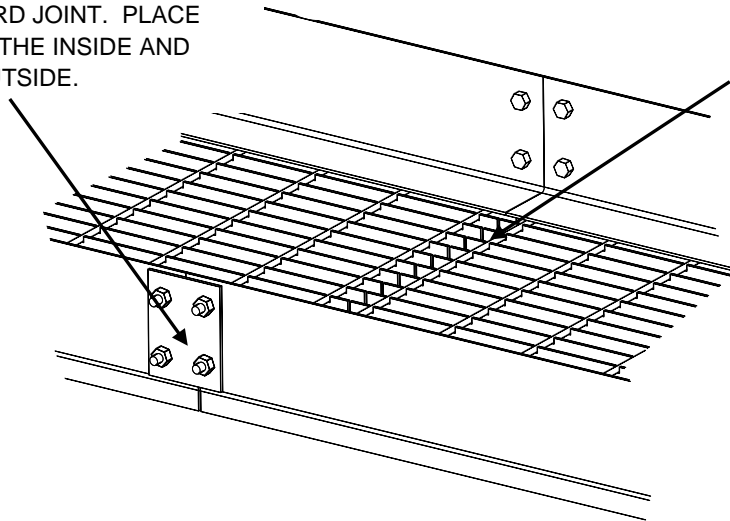

b. Punched Walkway Option: The punched walkway is joined in a similar fashion to the bar grating.

9. Make sure all nuts and bolts are tightened.

Note

Figure 20 on page 37 shows all the parts required for joining two modules together that are not part of the individual catwalk module. They are all part of a joining kit supplied with the order. Also included in the kit are all the screws, bolts and nuts necessary to make the connection.

Figure 20. Joiner Module Parts Locations

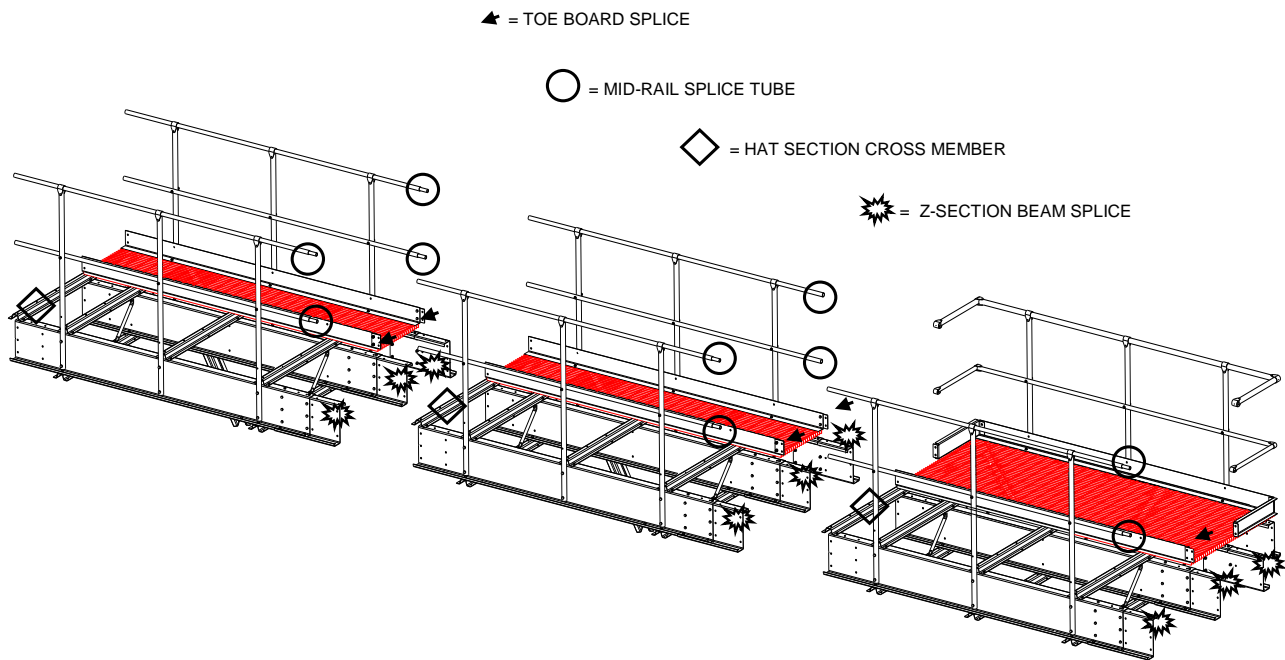

5.7.2 Heavy Duty Joiner Modules

Assembly of Heavy Duty Joiner Modules is similar to the Standard Duty Joiner Modules, except for Hand Rail Assembly.

1. Join the mating top hand rail tubes together using a handrail connection bracket as illustrated in [Figure 21 on page 38](#).

The orientation of the bracket should be the same as at other locations even though there are no posts or bracing tubes at this location.

Figure 21. Handrail Connection

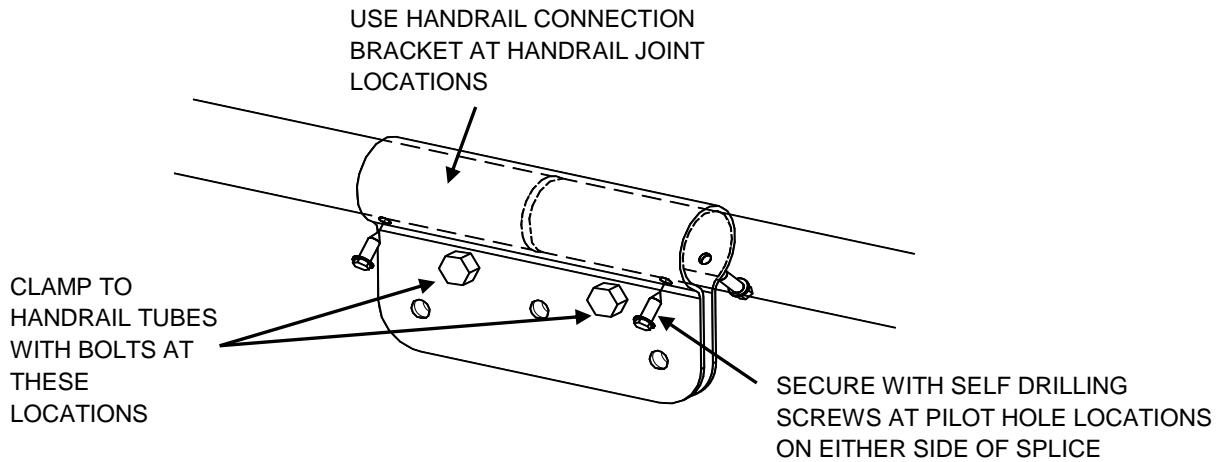

2. Use the two clamping bolt hole locations to secure the joint using 3/8" x 1" bolts.
3. Position bolt heads to the inside with nuts to the outside.
4. Install at least two self-drilling screws through the pilot holes, as illustrated, one on either side of the splice connection.
5. Use the short 152 mm (6") splice tubes to splice between mating mid rails. Insert one half of the short mid-rail splice tube into the end of one of the mid-rail tubes and secure with a self-drilling screw. Position the mating mid-rail tube over the splice tube and secure this end as well. It may prove beneficial to install the mid rails once the rest of the catwalk connection is made.

Figure 22. Mid Rail Connection

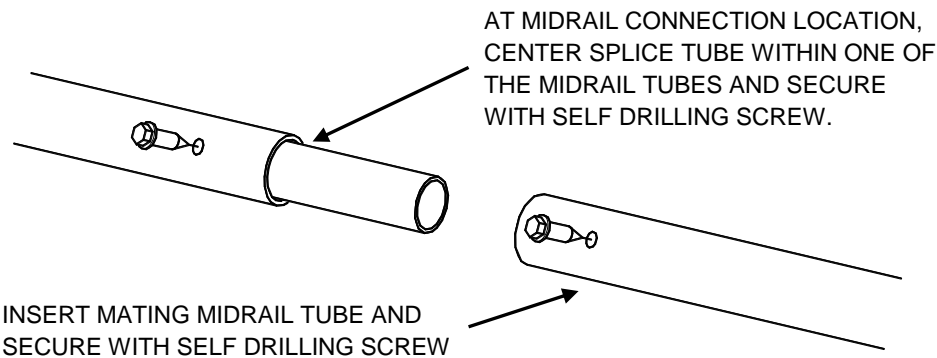

6. Diagonal tube braces bridge across every joint location. Bolt the diagonal tube braces on both sides as described in Heavy Duty Catwalk Section Assembly, [Step 2 on page 29](#). Position bolt heads to the inside.

Figure 23. Diagonal Tube Braces

BOLT ON 2 DIAGONAL TUBE BRACES (ONE ON EITHER SIDE OF THE CATWALK) ACROSS EVERY CATWALK MODULE JOINING LOCATION

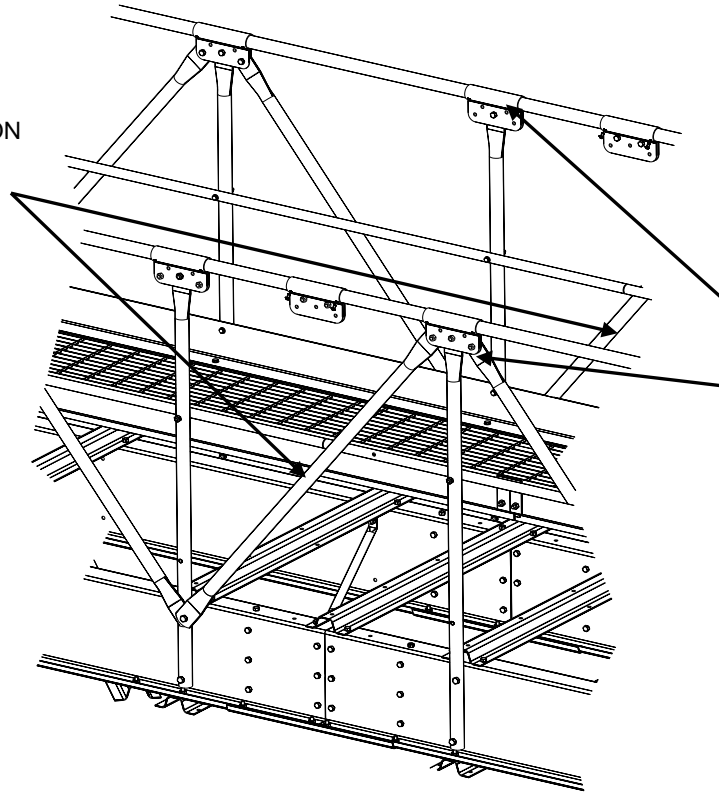

BOLT HEADS SHOULD BE POSITIONED ON THE INSIDE WITH NUTS ON THE OUTSIDE.

Note

Figure 24 on page 39 shows all the parts required for joining two modules together that are not part of the individual catwalk module. They are all part of a joining kit supplied with the order. Also included in the kit are all the screws, bolts and nuts necessary to make the connection.

Figure 24. Joining Modules Together

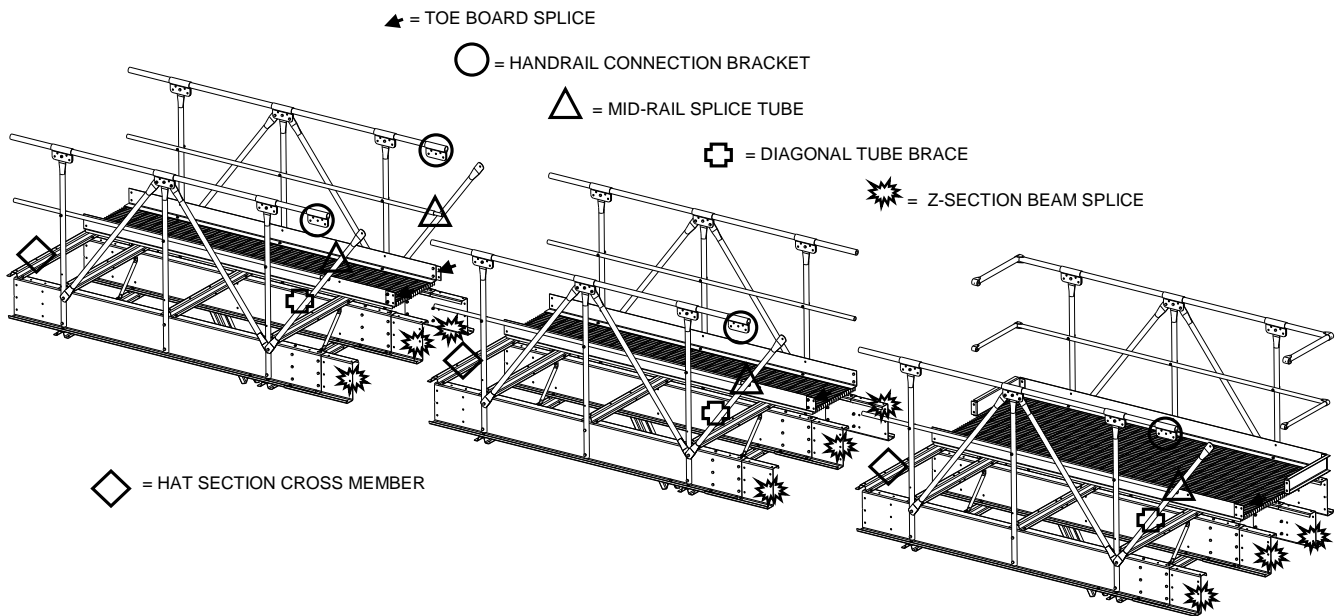

5.7.3 Thermal Joint

A thermal joint alleviates expansion and contraction concerns in extended catwalk runs. Some jurisdictions require a thermal joint at least every 40 m (130')

The optimum location for a thermal joint is between (but not directly above) neighbouring goal posts on two adjacent bins. If this is not feasible, consult with Westeel Applications Engineering

The only unique part in a thermal joint is a Z-section beam splice that has slotted holes to permit relative movement between mating sections of Z-beams. At the thermal joint, every connection should utilize the slotted Z-section beam splice.

Figure 25. Z-Section Beam Splice

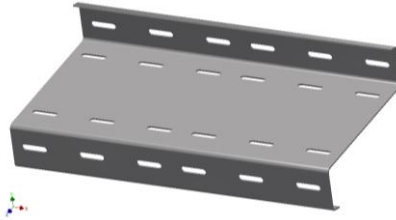

The assembly of the thermal joint is made as provided above with the following additional considerations. For Heavy Duty Catwalk railing systems see [Heavy Duty Catwalk Thermal Joint on page 41](#).

Standard Duty Catwalk Thermal Joint

1. When applying the hand rail and mid-rail splice only apply one self-drilling screws on one side of each joint. Do not secure the opposing side.
2. The slots on the Z-section beam should originally be centered on the mating holes in the catwalk Z-beams. Insure to use the 3/8" x 1" bolts with the adhesive strip applied. Snug the nuts to permit relative movement. **Do not over tighten.**
3. There will also be a gap between mating walkways. This cannot be avoided.
4. Slotted toe board thermal splices are used to span between the toe boards on mating modules.
5. Because of the gap that is created between mating walkways there is an additional top brace provided so that there are two for every thermal joint location. Move the top cross braces back from the thermal joint on either side one bolt hole location on the supporting Z-beams so the ends of the grating remain supported as illustrated in [Figure 27 on page 41](#).

Note

At the thermal joint leave a 40 mm (1 ½") gap between mating handrails, mid-rails and Z-beams.

Figure 26. Standard Duty Layout

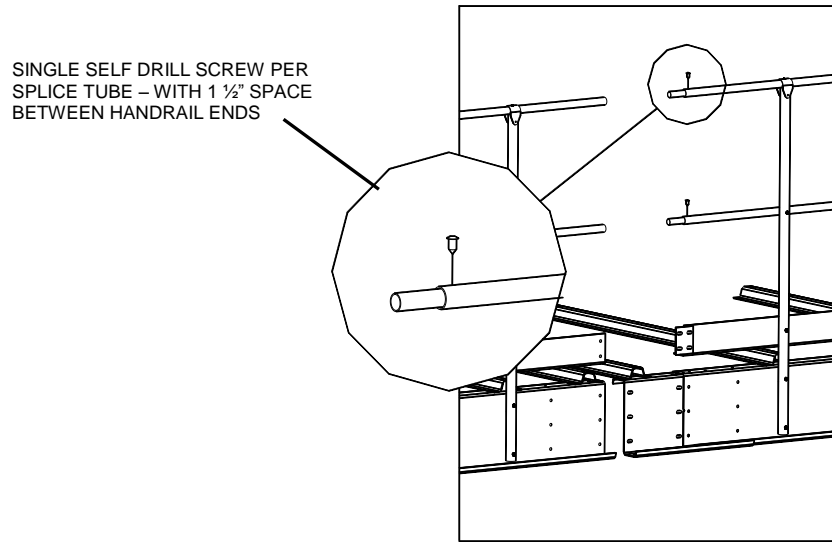
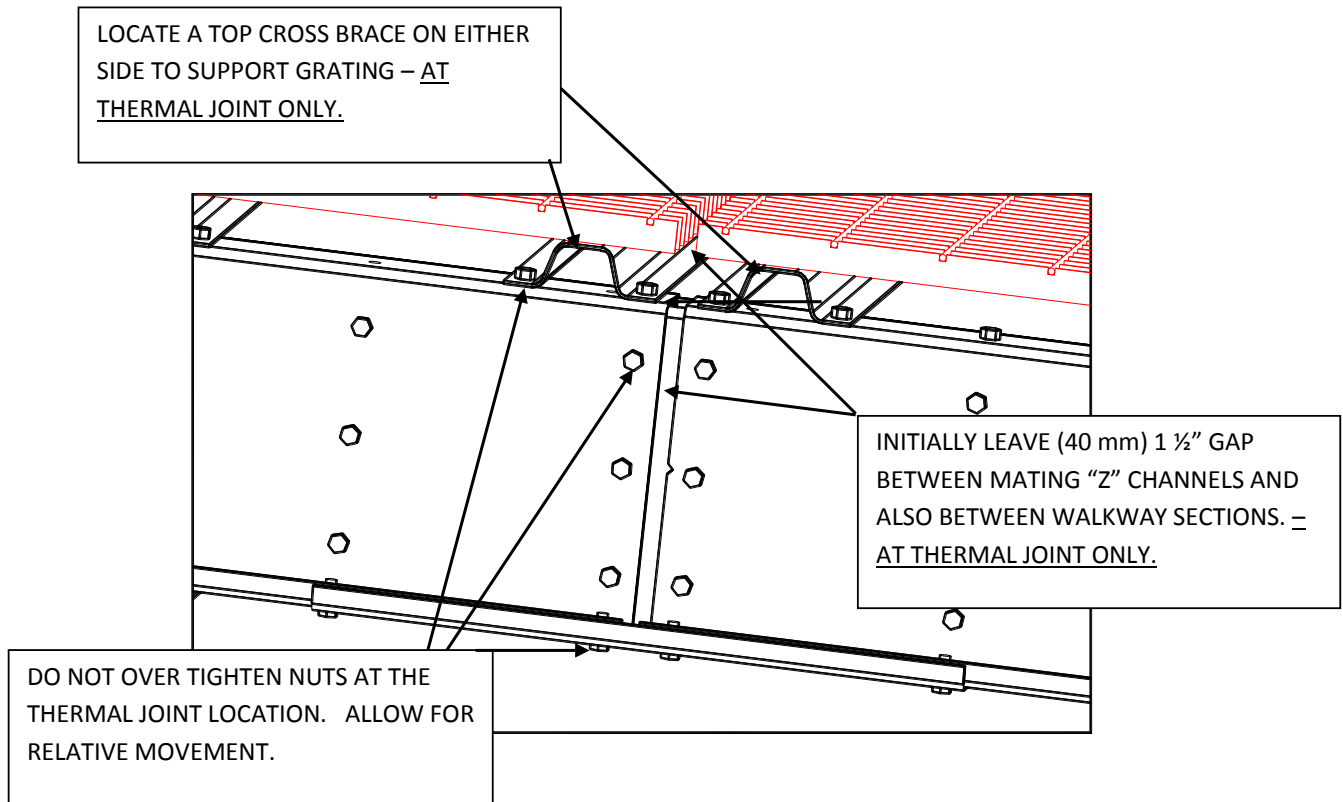

Figure 27. Top Braces



Heavy Duty Catwalk Thermal Joint

1. When applying the handrail brackets at a thermal joint do not tighten the nuts to the point where the bracket is squeezing the handrail tube. Leave enough slack to permit expansion and contraction. Also, use the self-drilling screws on only one side of the joint.
2. When applying the mid-rail splice only apply one self-drilling screw on one side of the joint.

- For the heavy duty catwalks, the diagonal brace that would normally span across a regular joint is not present as this would prevent relative movement across the thermal joint.

Figure 28. Heavy Duty Catwalk Layout

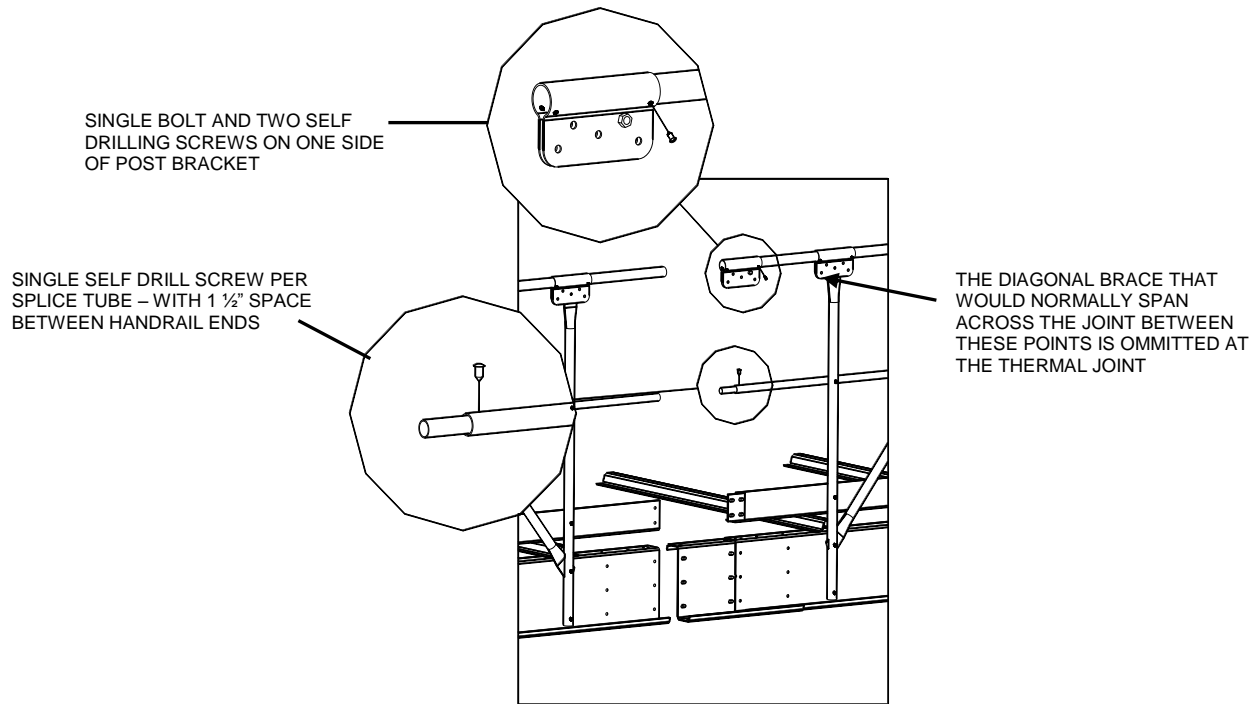

5.8. End Modules

The End Module closes the end of the catwalk. The End Module can be positioned on the end of any of the complete Catwalk Modules, or if desired the Catwalk Modules can be shortened to fit. However, if shortened some drilling of holes may be required depending on the location of the cut. Note that the bar grating option is illustrated. Options for the punched walkway options are illustrated at the end of the section. Special considerations for the Heavy Duty Catwalk are included at the end of each respective section.

5.8.1 Standard Duty End Modules

The procedure for installation of the End Module without cutting the Catwalk Module is as follows.

- Build the Catwalk Module as normal. The one exception is to relocate the top hat section cross member on the end back 187 mm (7.25") from its normal position and bolt in place as illustrated.

Figure 29. Relocate the top hat section cross member

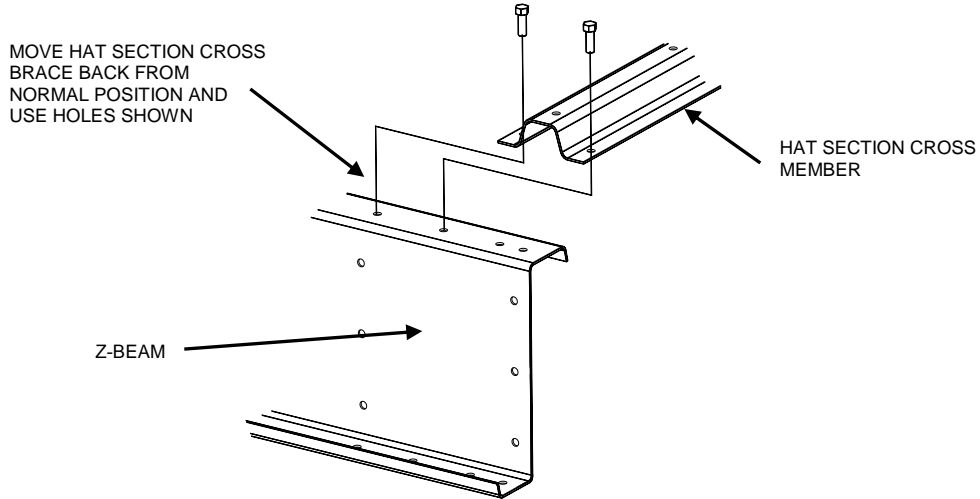

Note

For Heavy Duty Catwalk railing system see instructions at the end of this section.

2. Bolt on the end post (213049) onto the middle Z-beam using the vertical holes at the end. Use 3/8" x 2" bolts. The hole in the middle for attaching the mid rail will not align properly. Drill in a new hole at 90° to the existing hole.

Figure 30. Bolt on the end post

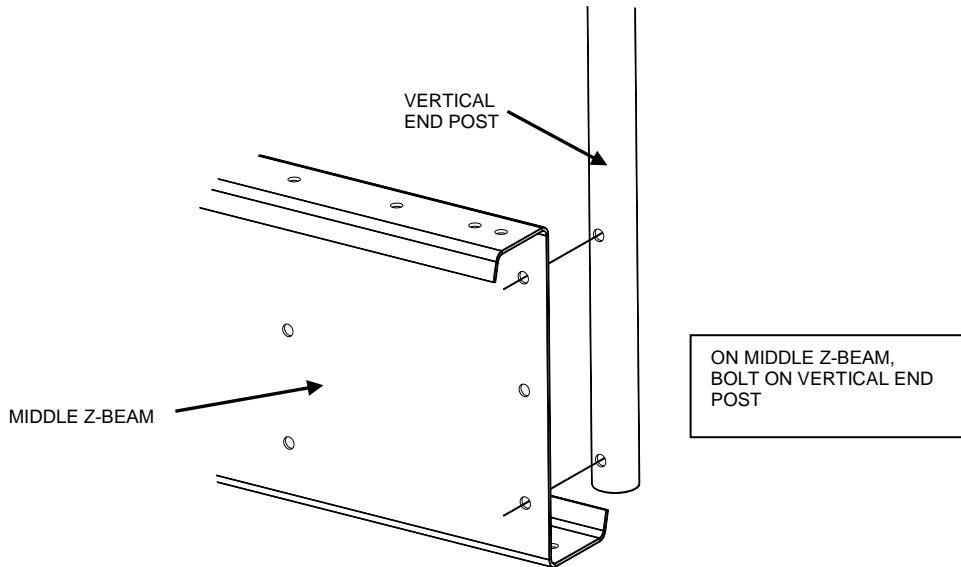

3. Bolt on the mid rail and secure handrail to top of post using the connector bracket in the same manner as illustrated in [Section 5.4 – Standard Duty Catwalk Section Assembly on page 23](#). Note that it may be necessary to shorten the horizontal rails to match the width of the catwalk in question. Place plastic end caps over exposed tube ends. Connect the end rails to the side rails with the corner connectors as illustrated.

Figure 31. Bolt on the mid rail and secure handrail

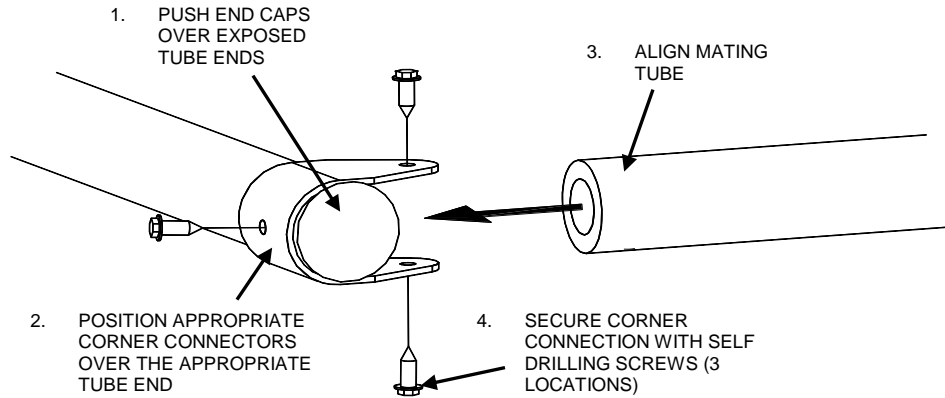

4. Bolt on the end toe board section to the base catwalk module as illustrated in [Figure 32 on page 44](#).

Figure 32. Bolt on the end toe board

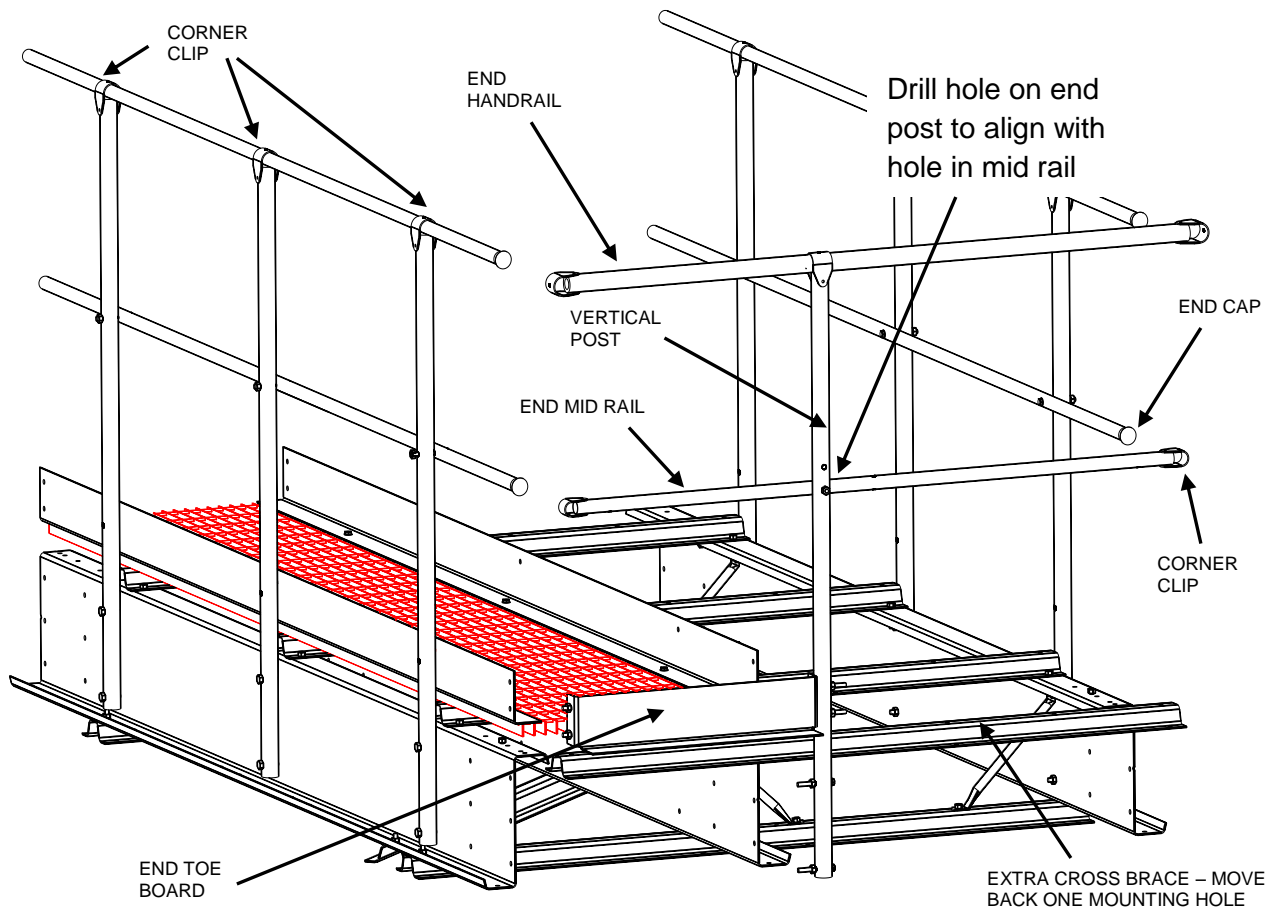

Note

If the catwalk extends beyond the conveyor, and if it is desirable to cover the end of the conveyor section with grating, extra grating can be laid over the top hat section cross members and secured to them. It may need to be cut to fit the opening. Extra grating, toe board sections and toe board corner splices will need to be ordered. A hat section cross member should be positioned under the grating edge to support it. (See [Figure 33 on page 45](#)).

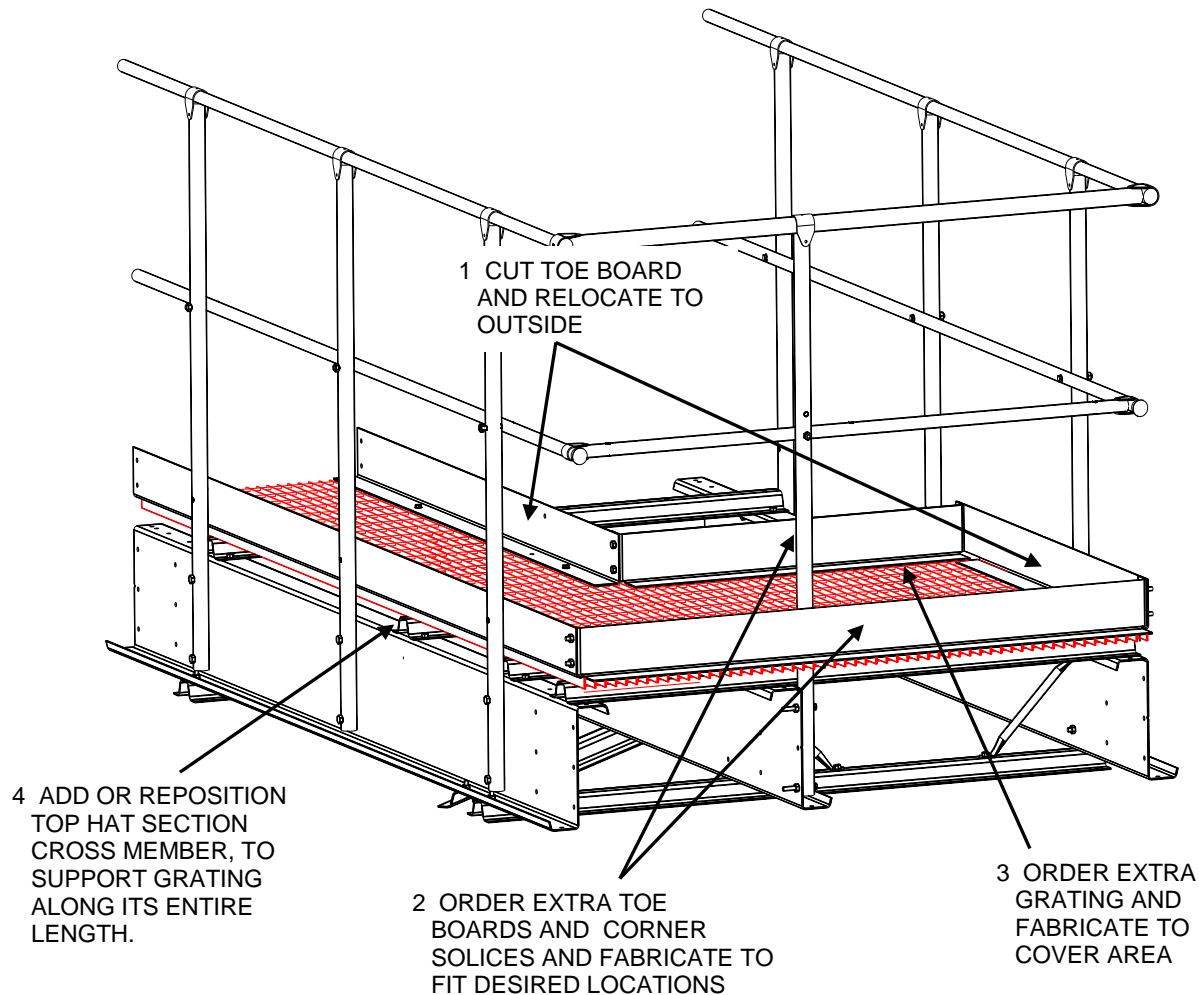
Figure 33. Catwalk extending beyond the conveyor**Note**

Extra grating must be cut and placed with the same orientation as the full section in order to be properly supported from underneath.

5.8.2 Shortened End Modules

The procedure for installation of the End Module if it is desirable to shorten the Catwalk Modules as follows.

1. The best location to shorten the Catwalk Module is just beyond any vertical post location as illustrated. Cut the Z-beams 197 mm (7.75") beyond the holes used to bolt on the vertical posts as illustrated in [Figure 34 on page 46](#).

Figure 34. Cut the “Z” beams

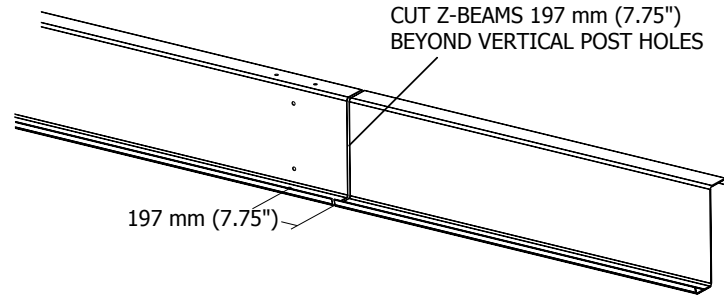

2. In the center Z-beam drill two holes as illustrated in [Figure 35 on page 46](#). These holes will be used to bolt on the end module vertical post. Bolt on the post.

Figure 35. Drill holes for end module vertical post

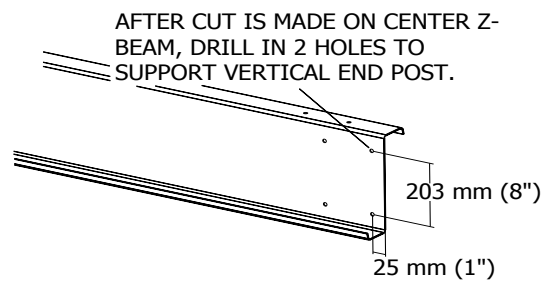

3. The rest of the installation follows the procedure describe above. It will be necessary to shorten the Catwalk Module hand rails, mid rails, toe board and grating to fit the installation.

Figure 36. Shorten hand rails, mid rails, toe boards and grating to fit

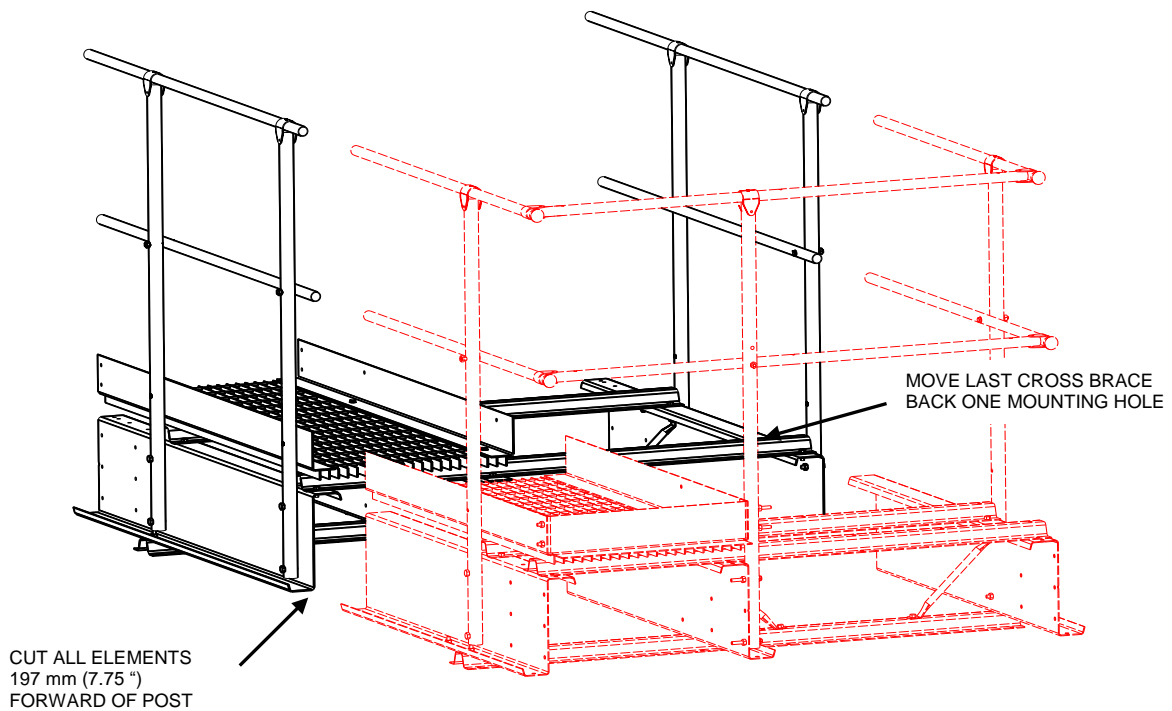

Note

It is possible to cut the Z-beams at other locations as well. However additional holes will be required to be drilled into the ends of the Z-beams to accommodate the other components. The template for hole location is provided in [Figure 37 on page 47](#). The installation of other components is essentially the same as provided above. Adjustments may be necessary to accommodate the actual installation.

Figure 37. Drilling Template

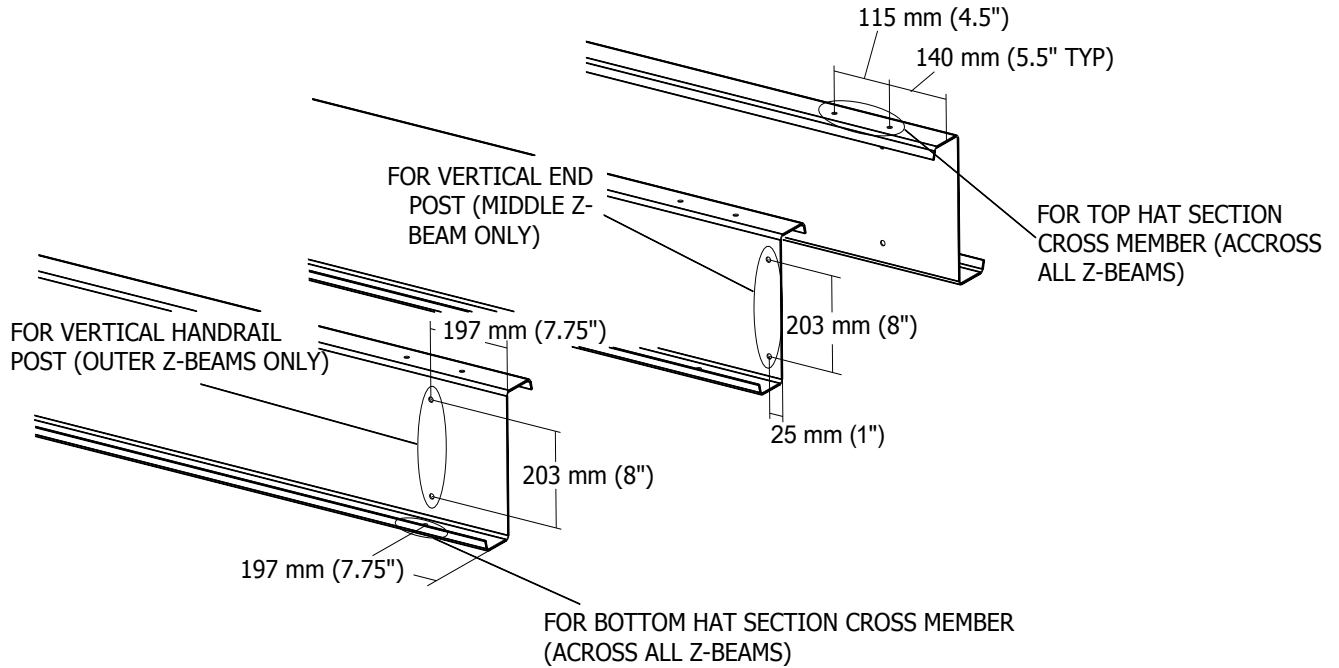

5.8.3 End Module in Combination with a Service Platform

The combination of an end module paired with a service platform module (shown in [Figure 38 on page 48](#)) may be desirable for some installations. In this case the handrails, mid rails and toe boards will not be long enough to cover the complete end. However the parts supplied within each module will be long enough if joined together. For this purpose extra parts have been provided within the service platform module to facilitate this possibility. This includes a handrail splice, a mid-rail splice and a toe board splice.

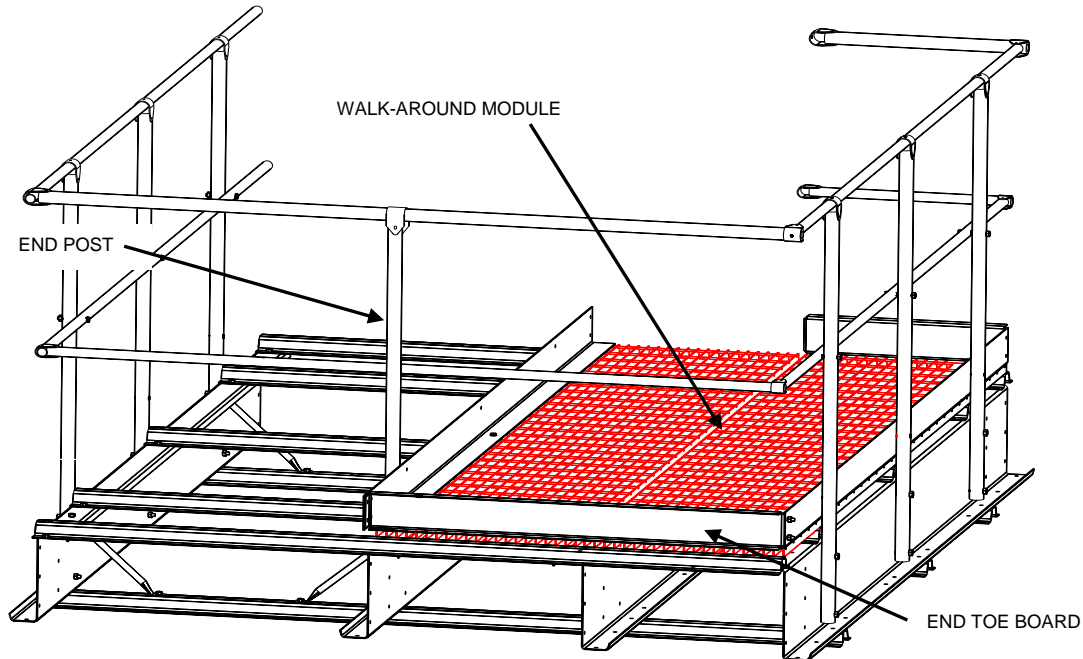
Figure 38. End Module in Combination with a Service Platform

5.8.4 Punched Walkway Options

The information provided in the previous section features the bar grating option for the catwalk walkway. The punched walkway option, with respect to catwalk end treatments, employs similar features. A straight run of catwalk without the need of additional walkway area at the end, is a straight forward application and employs similar installation procedures to those already provided elsewhere.

However if additional punched walkway area is desirable, such as to close off the conveyor section of the catwalk beyond the end of a conveyor, then a custom solution will be required (see [Figure 39 on page 49](#)). This will also require additional parts. Consult Westeel Applications Engineering for information and a specific solution. In general, keep in mind that the integral toe board will need to be removed in some locations to permit access. Since the punched walkway will be weakened by this action, any punched walkway edge, without the structural benefit of the integral attached toe board, will need to be supported from below. The most likely scenario is to position extra hat section cross members under these locations to provide support. This can be done laterally by insertion of an extra top hat section cross member, or longitudinally by cutting a hat section member to span between existing lateral spanning hat section members. Use self-drilling screws to secure members where no bolt holes are present. Also secure the mating punched walkway edges to the underlying supporting hat section member with self-drilling screws.

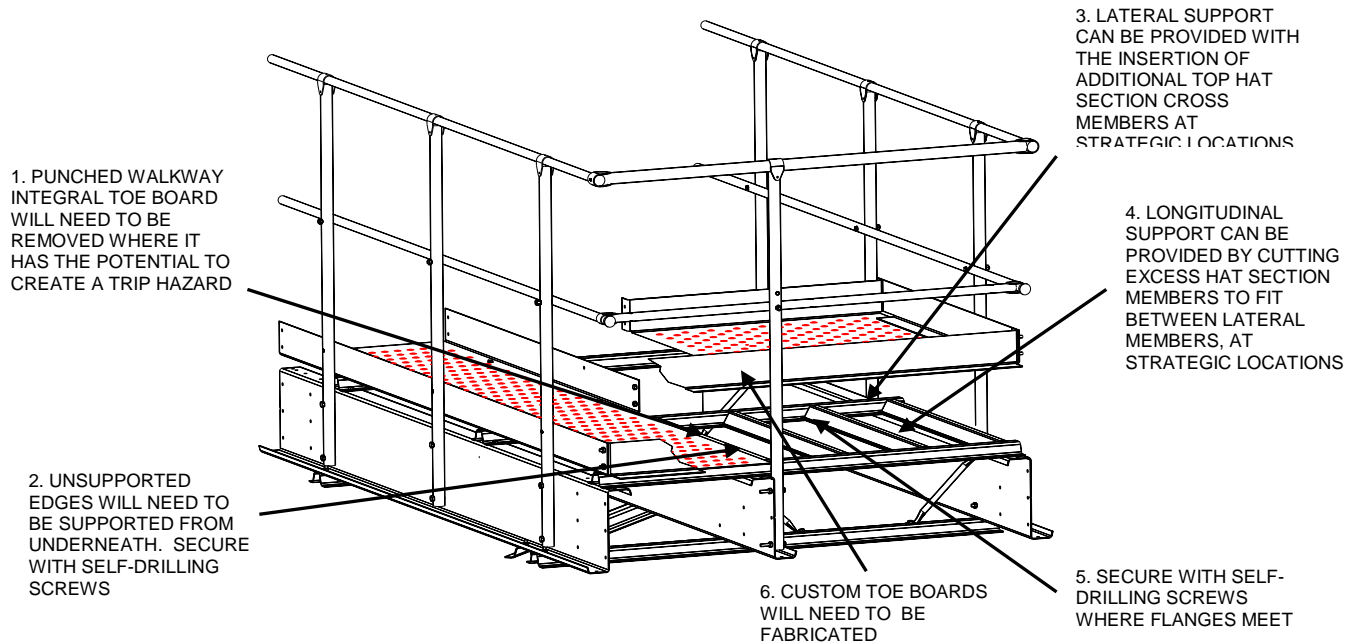
Figure 39. Punched Walkway Option

There is an additional consideration if the end of the catwalk coincides with a service platform. For punched walkways the service platform modules employs two punched walkways where the center section is folded down and is supported along the underlying Z-beams (See [Service Platform Insert Assembly on page 55.](#)) The section that is folded down is notched at every top hat section cross member location to allow the punched walkway to lay flat. If the service platform area coincides with the end of the catwalk, and because the end hat section cross member is moved back 187 mm (7.25"), the position of this end cross member will not align with the notches in the punched walkways. Both mating punched walkways will require a new notch to be cut into the folded down flange to coincide with the relocated cross member.

5.8.5 Heavy Duty End Module

The assembly of the Heavy Duty End Module is similar to the Standard Duty with the following differences as illustrated in [Figure 40 on page 50.](#)

1. The end post is heavier and flattened on the upper end (PN 213024).
2. The handrail is heavier.
3. The connection between the end post and the handrail is made using a handrail connection bracket.
4. The handrail corner clips and end caps are larger as required by the larger hand rail tube.

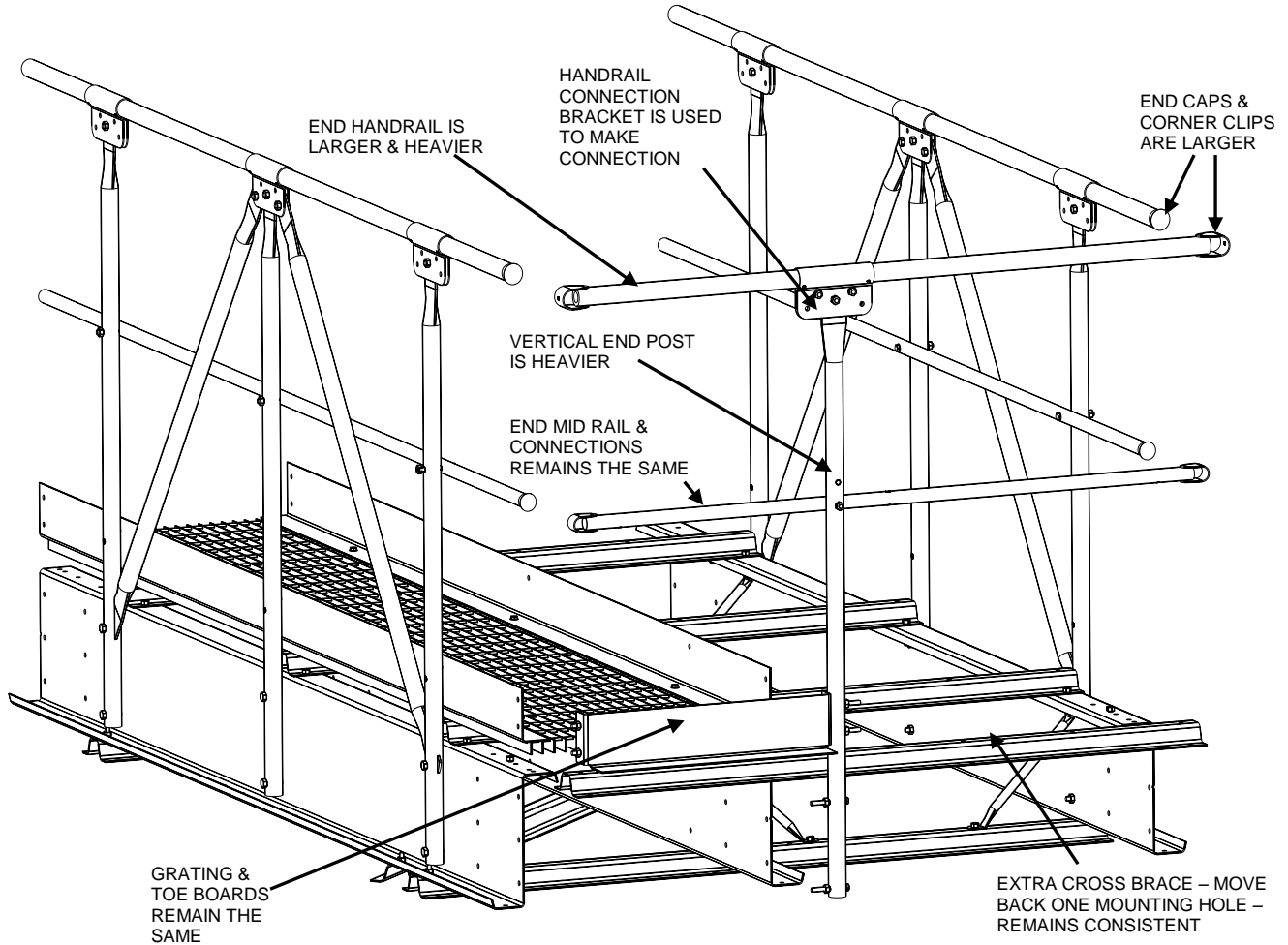
Figure 40. Heavy Duty End Module Assembly

5.9. Service Platform Module Assembly

The catwalk service platform modules are preferably located at peak ring locations (if desired) in order to create an additional 610 mm (24") of working space width. The modules are 3 m (118") long. If a longer space is required then 2 walk-around modules can be connected end to end. On Heavy Duty catwalks, the service platform should only be located at peak ring locations since the structural benefit of the trussed handrails gets discontinued at service platform locations.

5.9.1 Standard Duty Service Platform Module

The assembly of the Service Platform Module is very similar to the assembly of the base modules with the following differences.

1. There is one additional primary Z-beam. The extra Z-beam is located beside the outside beam on the walkway side and is in the same orientation as its neighbour as illustrated in [Figure 41 on page 51](#). Remember that the wider flange on the Z-beam is towards the top.
2. The hat section cross members (both top and bottom) are longer to accommodate the extra 610 mm (24") of catwalk width. However the installation procedure remains the same. The diagonal cross member that

bolts on the bottom is not used at service platform locations. Rather there is an additional bottom hat section cross member, making 3 in total. There are also five top hat section cross members:

- 3 positioned in the center
- 1 at each end

(See [Figure 41 on page 51](#))

3. The installation of the vertical posts remains the same. However on the extended side there are short handrail and mid-rail components with corner connectors to enclose the area and to reconnect to the mating handrails and mid-rails on the catwalk. Plastic end caps are provided to fit over the tubes. The installation of the corner connectors are as illustrated [Figure 41 on page 51](#) and as provided in greater detail in the End Assembly Module.

Figure 41. Installing posts, rails, and corner connectors

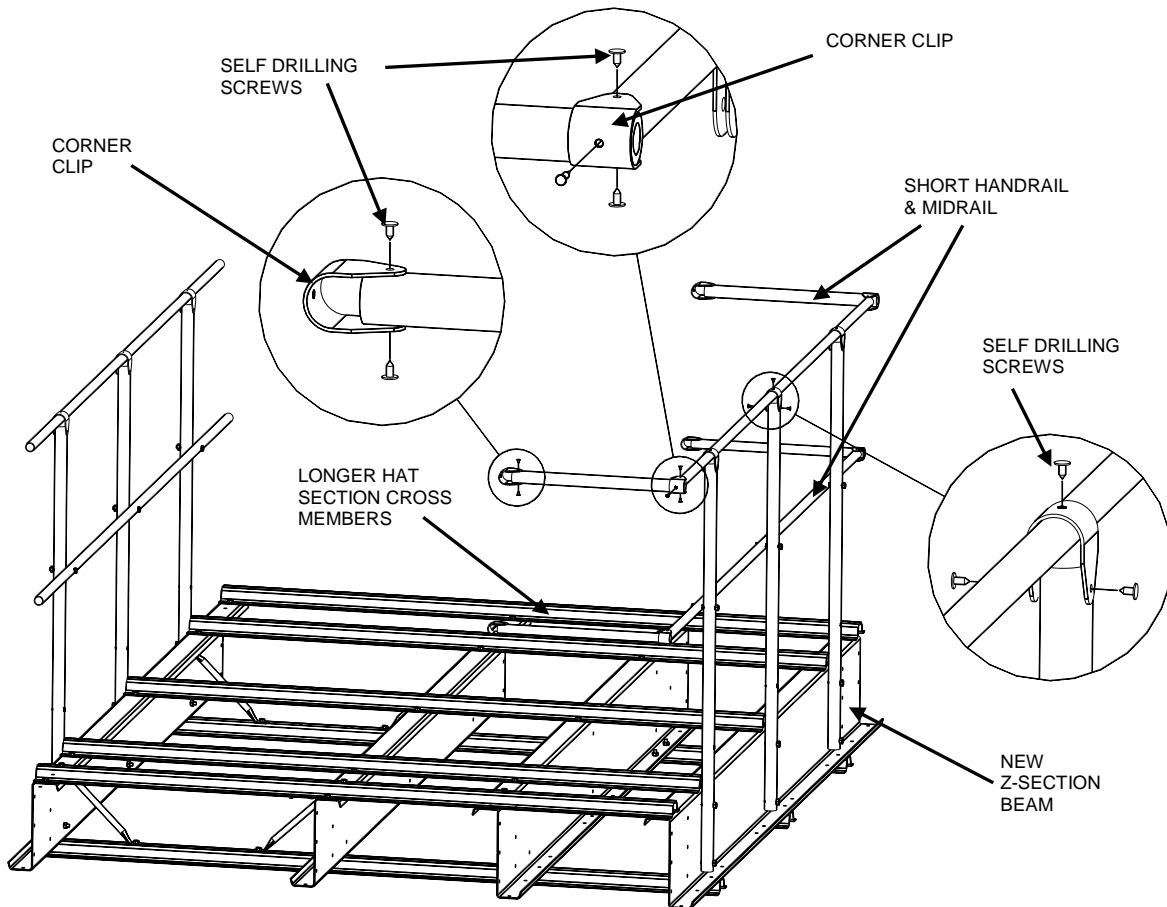

4. There are also short toe board connectors at each end of the extended walkway section. The installation is as illustrated in [Figure 42 on page 52](#) and as provided elsewhere.
5. Extra grating section that covers the extended region is included.

Figure 42. Installing toe board connectors and grating

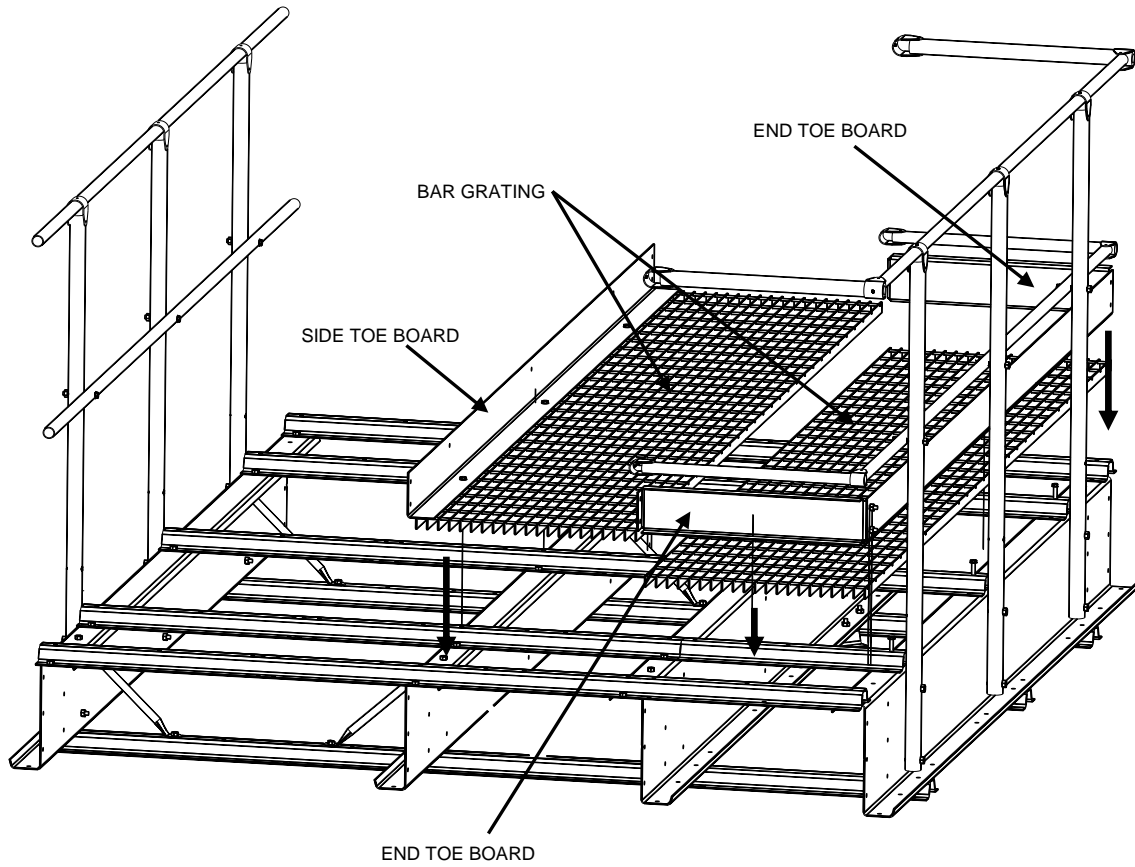
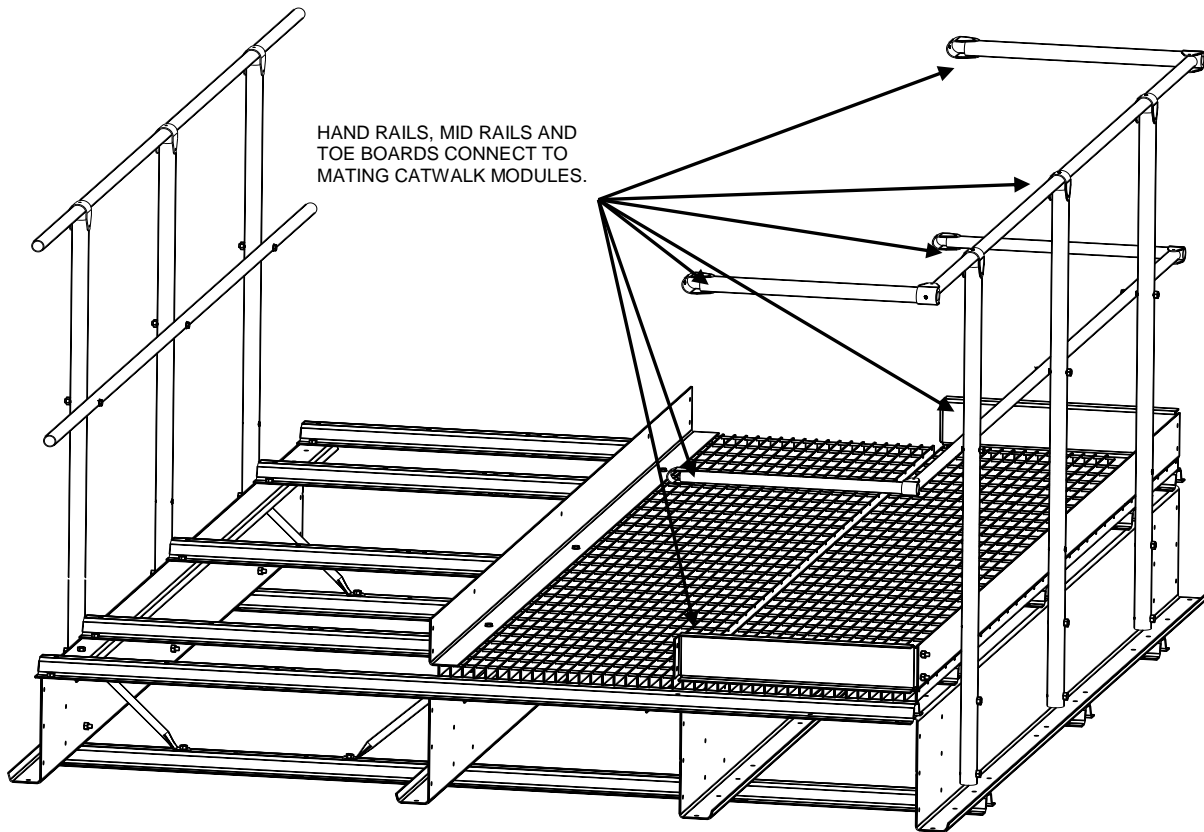

Figure 43. Completed 3M Standard Duty Service Platform Module**Note**

The service platform modules should be centered on the peak rings. For service platform modules with the bar grating option (as illustrated above), the outer additional 3 m walkway section [610 mm (24") wide] can be relocated and mounted farther up or down the catwalk, providing the five longer top hat section cross members and the three longer bottom hat section cross members are relocated along with the outer additional Z-beam and other necessary unique parts (i.e. hand rail, mid rail and toe board elements). However the parts that are removed at the insertion point (i.e. standard top and bottom hat section cross members) must be relocated and installed at the original location to complete the assembly.

Punched Walkway Option

The 3 m service platform module with the punched walkway option (see [Figure 44 on page 54](#)), must be inserted as a complete module at the appropriate location since the punched walkways are uniquely manufactured for this location. They feature a formed-down lip at the mating connection point which has material removed so as not to interfere with hat section cross members beneath, and which bears against the underlying Z-beam for support.

Most of the module is assembled as indicated above. The punched walkway is assembled as illustrated below. The two components bolt together along the formed-down lip. The walkway is then bolted to the underlying top hat section cross members.

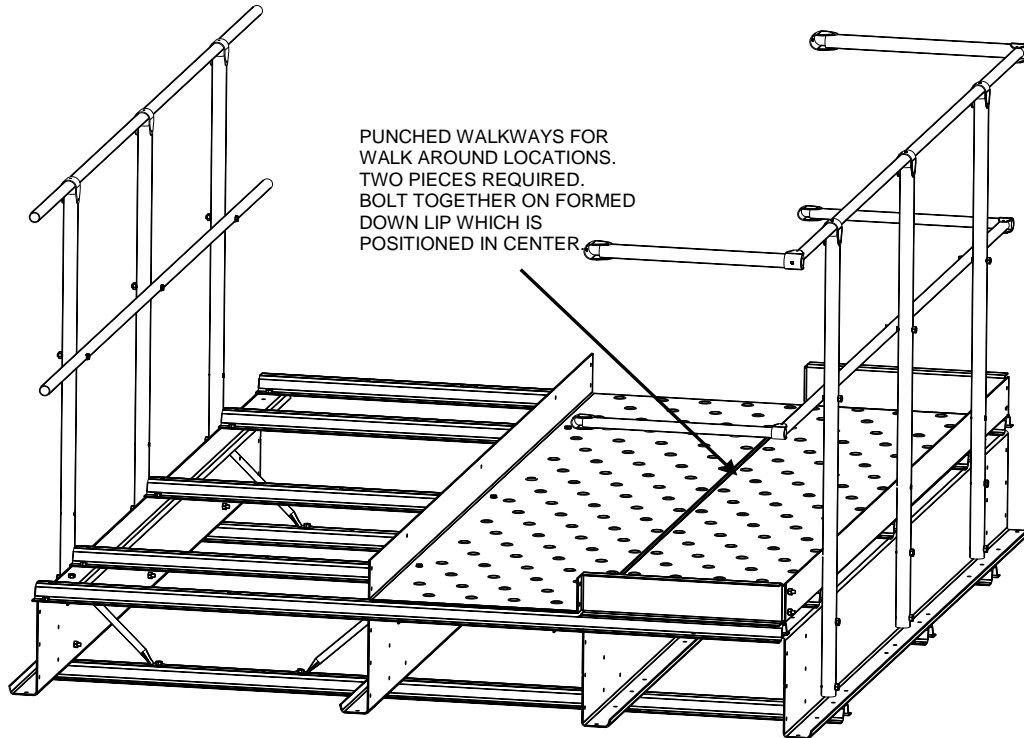
Figure 44. Punched Walkway Option

If the punched walkway location coincides with an end location, additional material must be removed on the formed down lip to avoid interference with the end top hat section cross member. See the End Module for a more detailed explanation.

5.9.2 Heavy Duty Service Platforms

Assembly of the Heavy Duty 3M Service Platform is the same as the Standard Duty Service Platform, except for the treatment of the handrails. As illustrated in [Figure 45 on page 55](#), the handrail components are assembled on the outside of the service platform in a manner consistent with the instructions provided for standard duty assemblies. Handrail and toe board to catwalk connections are as described in the Standard Duty section, but Heavy Duty Service Platforms have heavier top rails. They also utilize large corner clips and plastic end caps.

Figure 45. Completed 3M Heavy Duty Service Platform Module

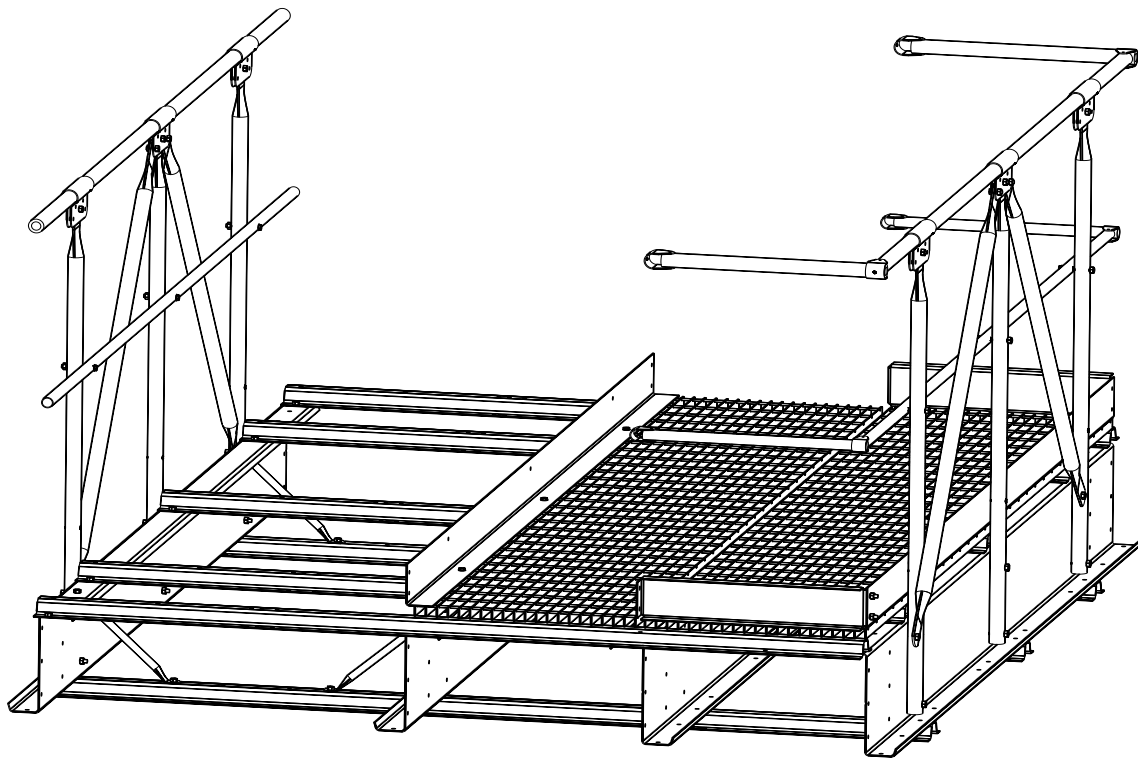

5.9.3 Service Platform Insert Module

The service platform insert is a 3 m section that can be bolted onto the walkway side of a regular catwalk at almost any location. It is restricted to standard duty, bar grating walkway options only.

The hand and mid rails, vertical posts, toe boards and rail corner clips are provided with the primary catwalk. They are relocated to the outside of the service platform insert. Additional railing, toe board and corner clips are provided to reconnect to the primary catwalk.

Catwalks are subject to load/span limitations and must be adequately supported. Check specific site drawings for required support locations

Service Platform Insert Assembly

The service platform insert comes with one additional Z-support beam, five top cross braces, and two bottom cross braces. (See [Figure 46 on page 56](#)) The cross section of the cross braces allows them to fit over the corresponding cross braces on the primary catwalk to extend their reach to accommodate the additional 650 mm (25.6') of walkway. The holes in the service platform cross braces align with existing holes in the primary catwalk cross braces. Once the cross braces have been extended, the rest of the assembly is consistent with the information provided for the Standard Duty Service Platform with bar grating option. Note that the hand rails and toe boards provided with the service platform will need to be cut to accommodate the transition back to the primary catwalk. Corner toe board clips are provided to connect the toe boards.

Figure 46. Service Platform Detail

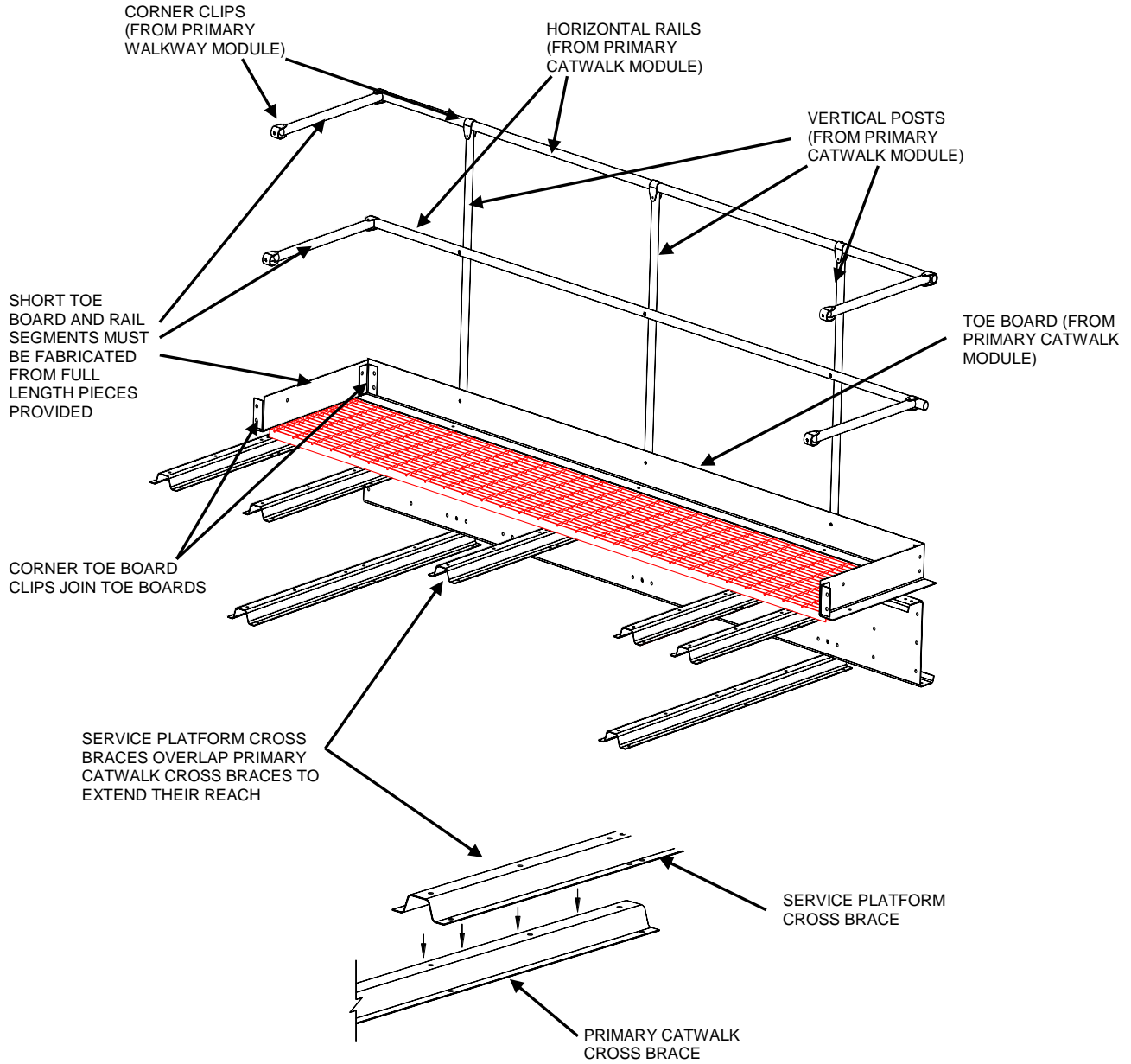

5.10. Cross Catwalk Modules

Cross Catwalk Modules allow for a 90° intersection of a primary catwalk and cross catwalk. Typically the connection is made to the walkway side of the primary catwalk. The intersection should only occur at a point of vertical support, such as at the peak ring, or at a tower, or grain bin goal posts. The combined load of the primary catwalk and of the intersecting catwalk needs to be taken into consideration when determining the suitability of the vertical support. Consult Westeel Application Engineering for specific installation requirements.

Note

90° crossover sections can only be attached at a point of vertical support, such as at the bin peak ring, or at a tower, or grain bin goal posts. The first and last sections of the crossover must be the specially notched 3 meter “Z” sections. Standard sections can be used to complete the span but may need to be cut to fit.

The cross catwalk module can be arranged such that the conveyor support section is on the right or left side of the walkway by rotating it end for end. Both ends of the mating “Z” beams on the Cross Catwalk Module are notched to avoid interference with the lower “Z” beam flange on the primary catwalk.

5.10.1 Standard Duty Cross Catwalk Module Assembly

The Cross Catwalk Module is initially assembled in the same manner as the primary catwalk modules. The notched ends of the Z-beams are positioned on the bottom. The primary structural connection between the primary catwalk and the mating Cross Catwalk Module is made with the use of the Crosswalk Bracket angles as illustrated below. There are two Crosswalk Brackets at every Z-beam connection point: one pointing in each direction.

When mating a Cross Catwalk Module with a 3m Catwalk Module, the Cross Catwalk Module center Z-beam aligns with the Catwalk Module center vertical post bolt holes. Once this connection is made, the rest of the holes should align, eliminating the need to drill holes.

Figure 47 on page 57 illustrates the structural connection between a standard 3 m Catwalk Module and the mating Cross Catwalk Module. Use 3/8” x 1” bolts and flanged nuts to make the connections.

Figure 47. Cross Catwalk Module Connection

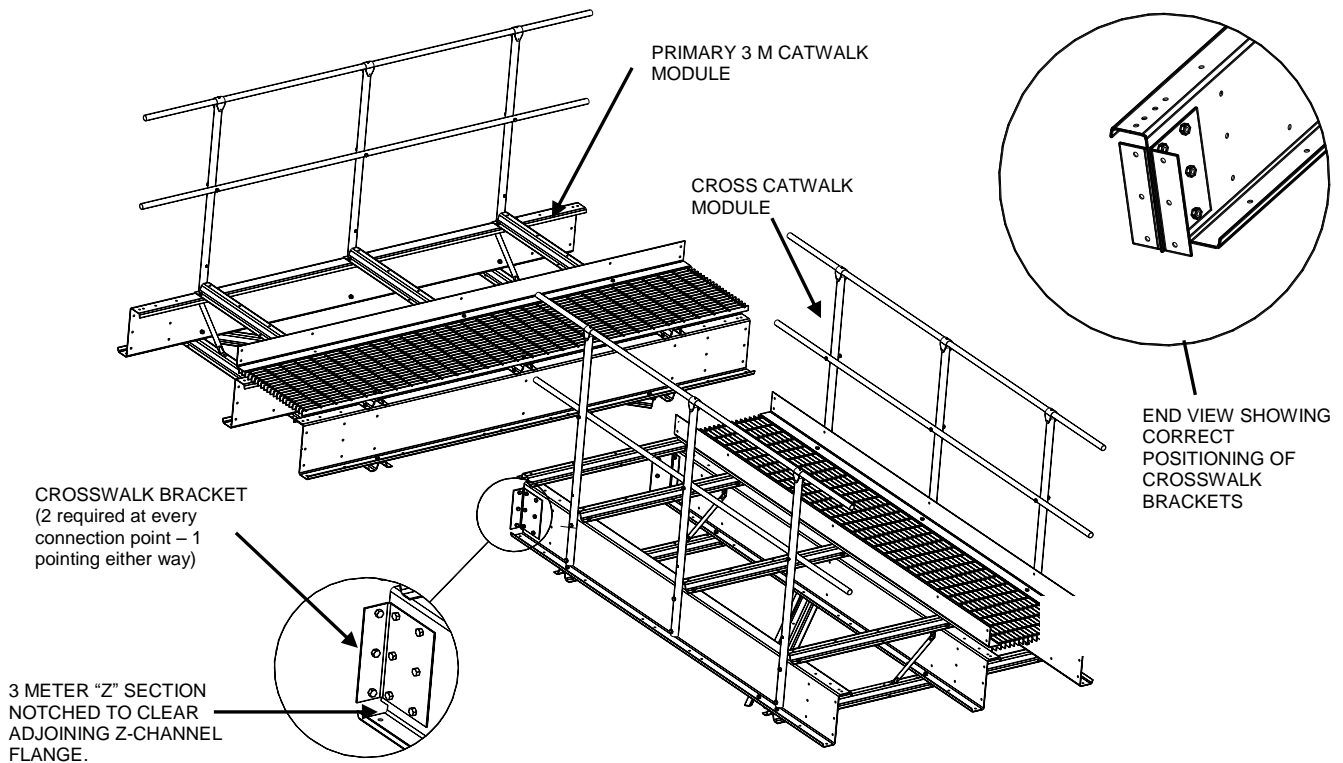

The Cross Catwalk module can also be located at other locations on the standard 3 m Catwalk Modules and on the standard 6 m and 9 m modules. However the mating holes at the Z-beam connection points will need to be field drilled.

Some handrail and toe board components on the primary catwalk sections will become redundant once the connection is made. These can be set aside for use elsewhere if required. If the point of installation does not coincide with the center of a 3 m standard catwalk module, these parts can be cut as required to make up the gaps between the point of cross walk insertion and the primary catwalk components

Once the structural connection is completed, the balance of the parts can be added to complete the assembly. This includes handrail, mid-rail and toe board components as illustrated below. The corner connections on the rails are made as illustrated elsewhere. Toe boards also bolt together at corners using 3/8" x 1 bolts (with adhesive strip) and flanged nuts. Bolt heads go towards the inside with nuts on the outside.

Figure 48 on page 58 shows the added components needed to connect modules together to create a completed cross-over assembly.

Figure 48. Components Needed to Connect Modules

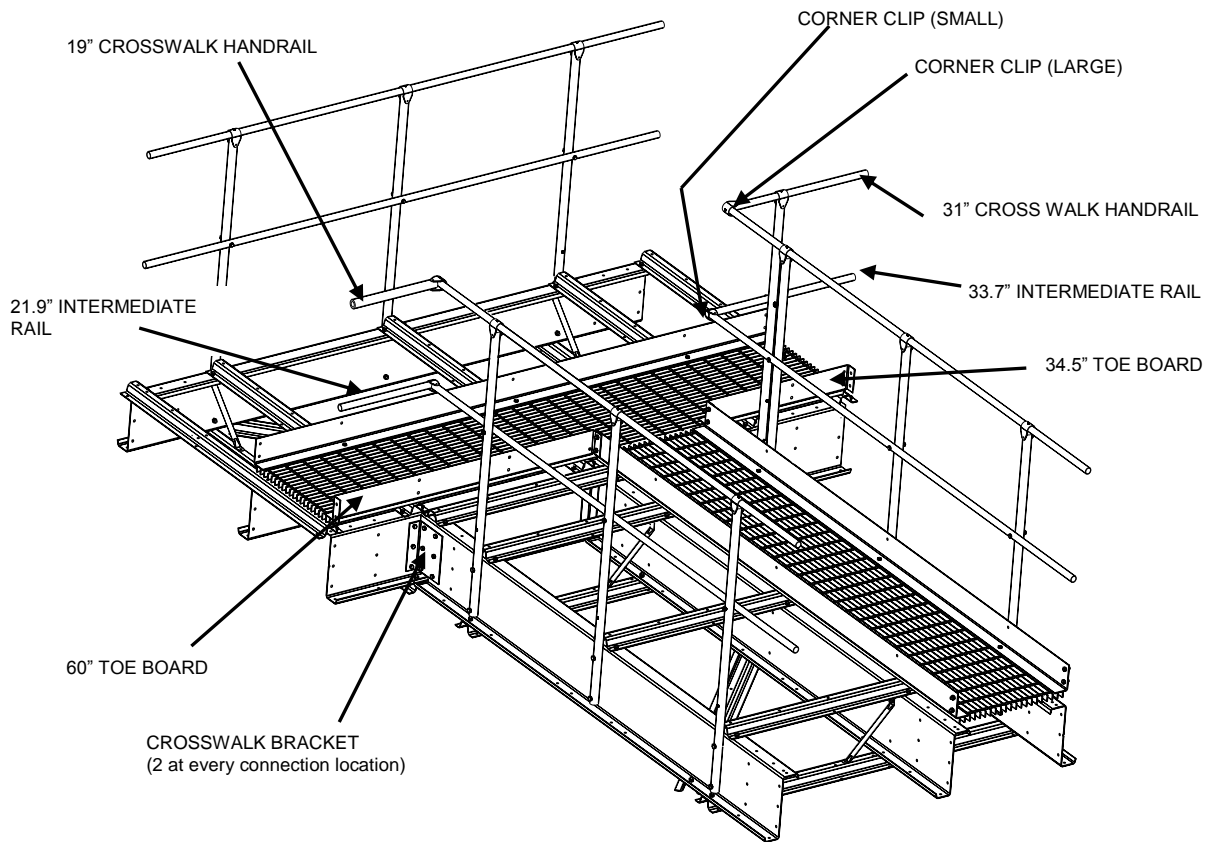

Note

- Every exposed handrail end needs to be fitted with the appropriate end plug
- Every corner clip needs to be secured with self-tapping screws (3 per clip)

The Cross Catwalk Module can also be attached to the Walk-Around Module as illustrated below. The Walk-Around Module is typically assembled as part of the primary catwalk. The Cross Catwalk Module is then added as per the instructions provided above. Note the additional parts to complete handrails, mid-rails and toe boards. These are provided as part of the Walk Around Module.

Figure 49 on page 59 illustrates a completed Cross Catwalk connection to a Walk Around Module.

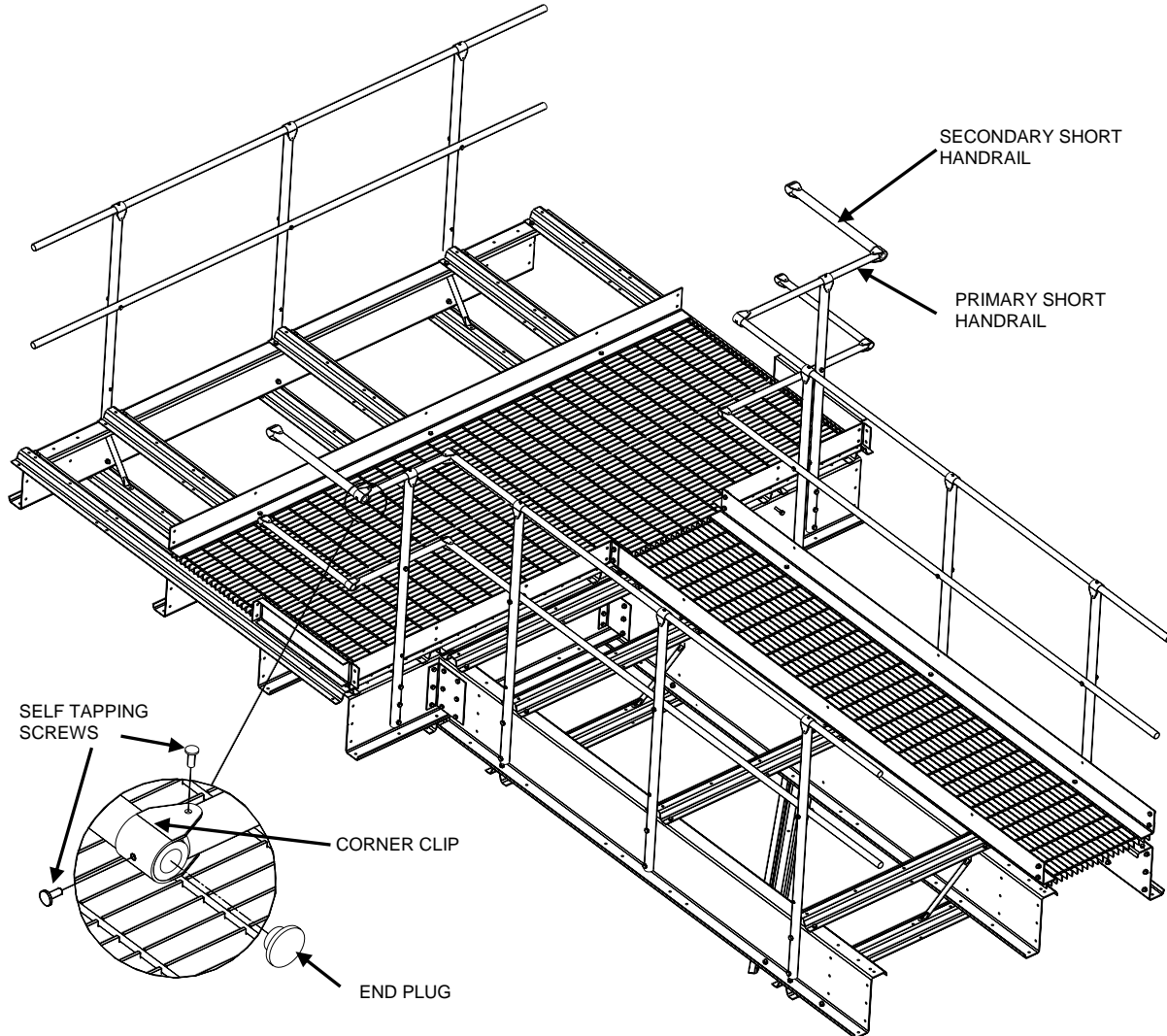
Figure 49. Completed Cross Catwalk Connection to a Walk Around Module

Once the cross connection is established, the center section of the cross catwalk can be any combination of standard 3 m, 6 m and 9 m catwalk modules. It may be necessary to shorten a module in order to fit the space between primary catwalks. If this is required it is recommended that the end of a standard module be shortened as required. Holes in the Z-section will need to be drilled to match the standard ends. Other components will need to be shortened as required.

Punched Walkway Version

The punched walkway version of the Standard Duty Cross Catwalk Module (see [Figure 50 on page 60](#)) is assembled in the same manner as above, except that the integral toe board on the primary punched walkway must be removed (i.e. cut out) at the point where the intersecting punched walkway meets it. Corner toe board splices are provided to connect the intersecting toe board locations. Since the cut edge is weakened with the removal of the integral toe board, this section must be supported underneath. This can be achieved by utilizing a surplus hat section. Cut the hat section to fit and bridge between existing laterally positioned top hat section cross members to provide longitudinal support at the punched walkway intersection point. Secure with self-drilling screws.

Figure 50. Punched Walkway Version of the Standard Duty Catwalk Module

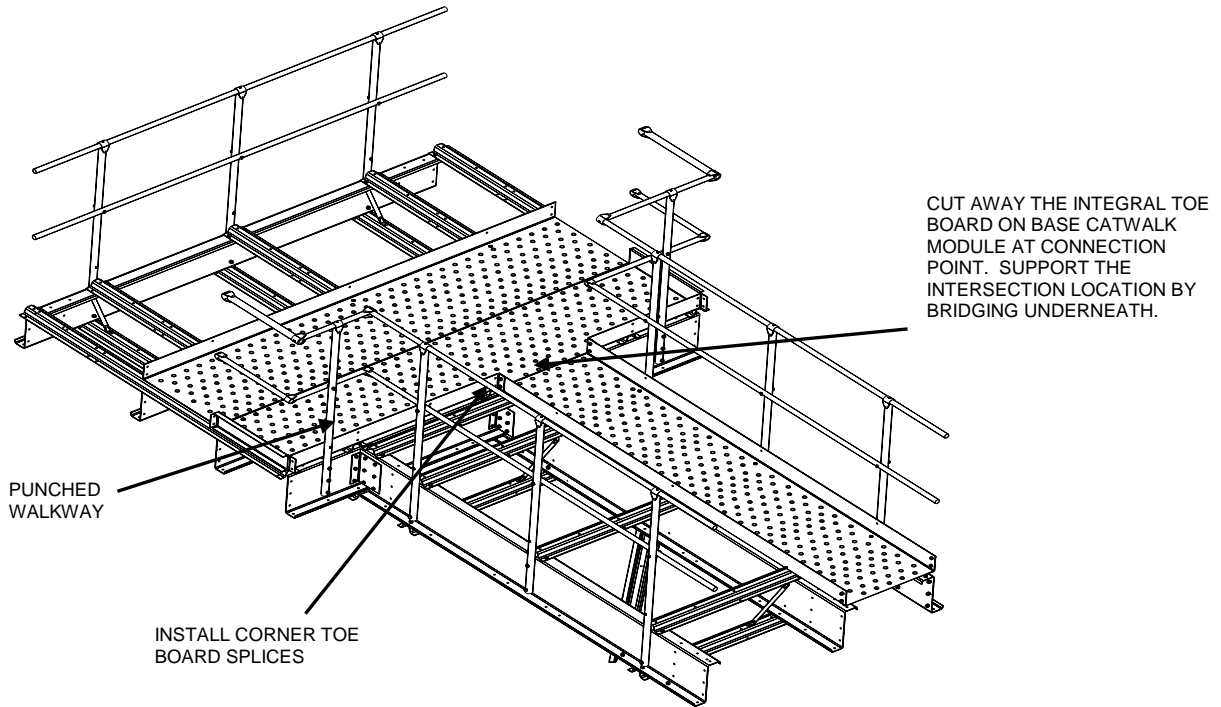

5.10.2 Heavy Duty Cross Catwalk Module Assembly

The assembly of the heavy duty version is identical to the standard duty version except for the treatment of handrails, which feature the trussed handrail concept and a heavier handrail. The installation of these elements remains consistent with the information provided for the Heavy Duty Standard Catwalk Modules. The heavier handrail connections are made utilizing larger corner clips and plastic end caps. A completed Heavy Duty Cross Catwalk connection is illustrated in [Figure 51 on page 60](#).

Figure 51. A completed Heavy Duty Cross Catwalk connection

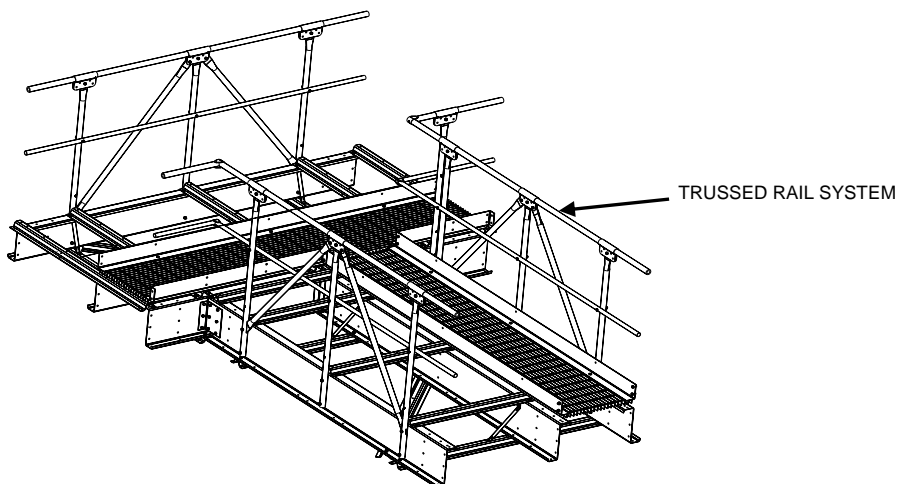

5.10.3 Cross Catwalk Variations

There are walkway only modules featuring a single walkway (650 mm (25.6")) wide or a double walkway (1300 mm (51.2")) wide which can be utilized in a cross configuration. The assembly of these modules is provided elsewhere. The cross walkway connections are essentially the same as provided above. Cut the set aside handrails and toe boards from the primary catwalk to fill in necessary gaps as provided above.

5.11. Peak Ring Support Module

When supporting a catwalk at the peak ring location on a grain bin one of seven Catwalk Peak Ring Support Modules must be specified. The different sizes correlate with the three different peak ring diameters, whether the roof is non-structural or structural and the maximum loads capable of being supported by the peak ring support module as indicated below.

Table 6. Peak Ring Maximum Loads — Non-Structural Roofs

Part Number	Bin Diameter	Peak Ring Diameter	Maximum Load
213140	15' to 27'	840 mm (33")	15' to 24' – 3,600 kg (8,000 lbs) 27' — 4,500 kg (10,000 lbs)
213141	30' to 48'	1320 mm (52")	4,500 kg (10,000 lbs)
213142	51' & 54'	1525 mm (60")	5,400 kg (12,000 lbs)

Table 7. Peak Ring Maximum Loads — Structural Roofs

Part Number	Bin Diameter	Peak Ring Diameter	Maximum Load
213143	48', 60' to 96'	1320 mm (52")	27,200 kg (60,000 lbs)
213144	51, 54, 102 to 108'	1525 mm (60")	27,200 kg (60,000 lbs)

Standard Catwalk Peak Support Modules consist of two Z-beams, four support beams and associated hardware. The Z-beams are common to all sizes. The support beams are unique to each peak ring diameter.

The same Z-beams are also used at the top of catwalk eave support posts and corresponding knee braces so there are a number of holes punched for different applications. The following provides a guide as to which holes are utilized for the assembly of the seven Catwalk Peak Ring Support Modules.

Figure 52. Z-Beam indicating holes for assembly

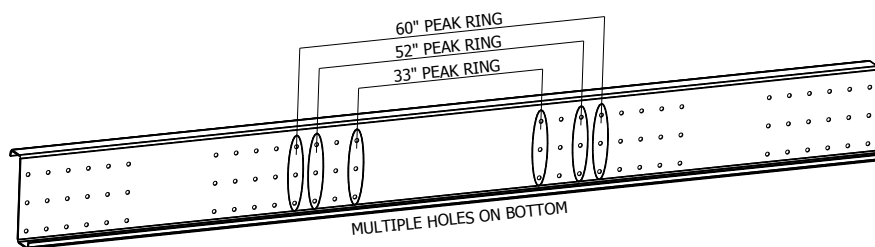

When assembling the Catwalk Peak Support Modules, the wider Z-flange on the beam is located on the bottom and pointing outwards. Conversely the mating support beams flanges are pointing outwards at the top and inwards at the bottom. Bolt the parts together as illustrated utilizing 1/2" x 1 1/2" bolts and flanged nuts.

Figure 53. Orientation of the Z-beams

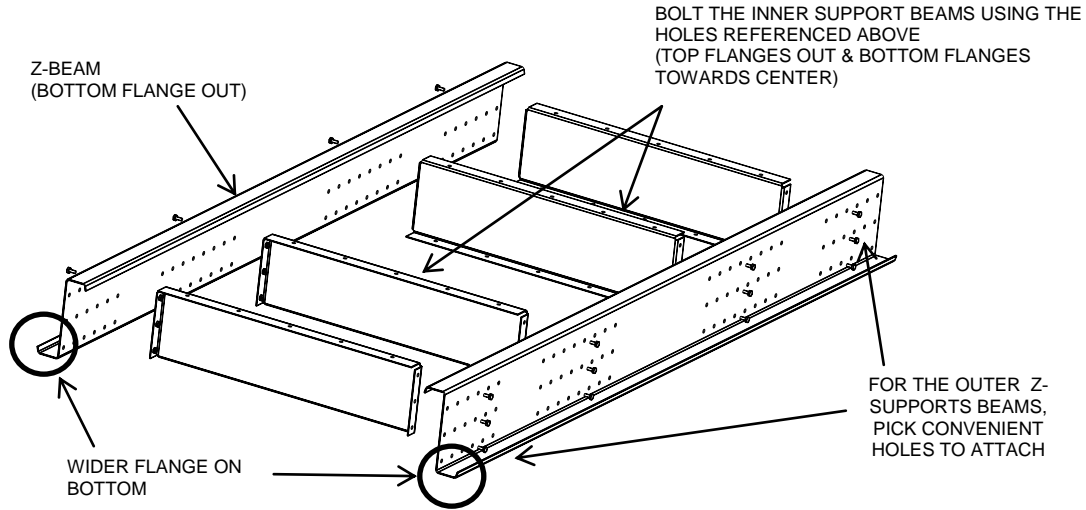

For the structural roofs involving large vertical load transfers (213143 & 213144) of greater than 13600 kg (30,000 lbs), the Z-beams will be required to be a double section. For these applications a Z-laminate is provided. Two mating Z-sections will nest together as illustrated. The balance of the assembly is as indicated above.

Figure 54. Doubling the Z-beams

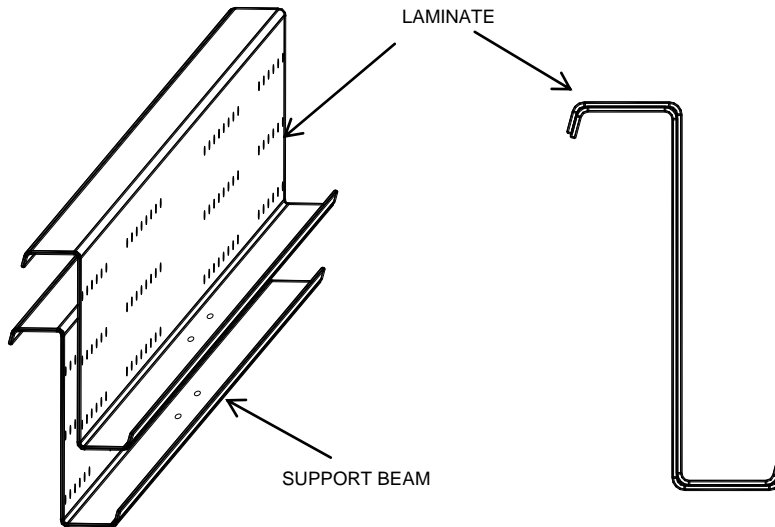

Next, center the completed assembly on top of the flat cap and mark all of the hole locations. Field drill holes and bolt the channel assembly onto the flat cap using 1/2" x 1 1/2" bolts and nuts. Secure the flat cap to the peak ring as provided in the corresponding grain bin manual such that the supporting Z-channels are perpendicular to the direction of the catwalk. Additional support is also required as provided below.

Figure 55. Completed assembly on the flat cap

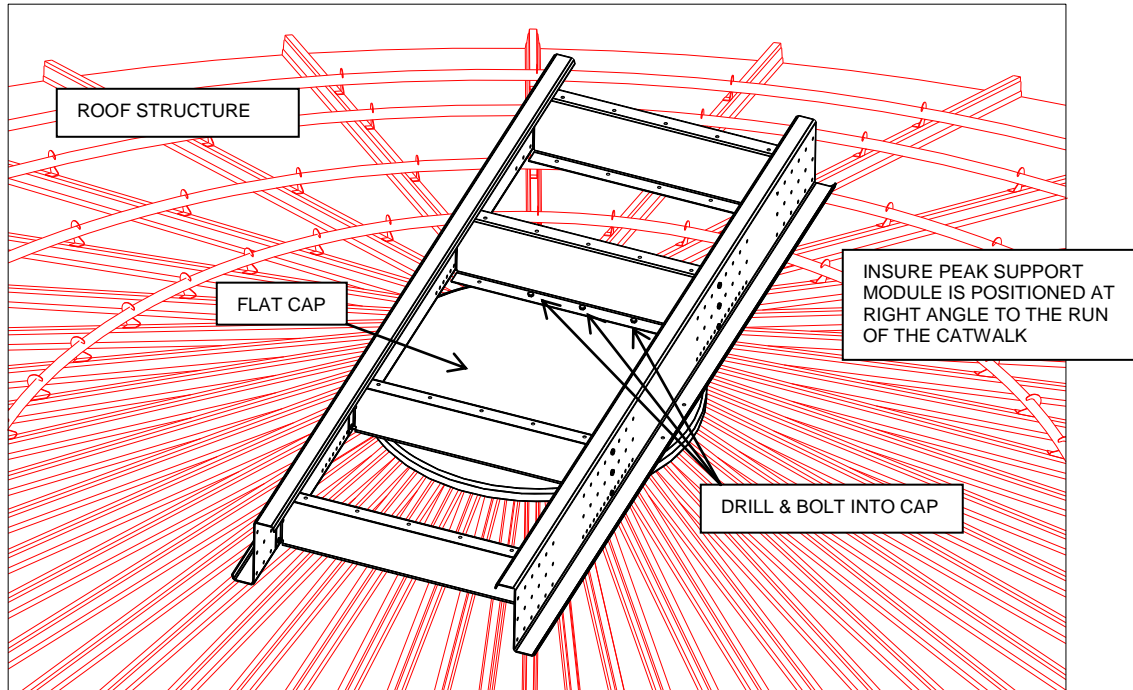

5.11.1 Non-Structural Roofs

Flat Cap Clips (213437) are provided to aid in the securing of the flat cap to the peak ring. The clips are oriented as illustrated in [Figure 56 on page 64](#). The bottom two holes pick up on the existing 5/16" hardware used to secure the roof panels to the peak ring. The upper hole must be drilled into the flat cap and secured with a 1/2" x 1 1/2" bolt and nut. The location of the clips is flexible. However they should be distributed such that they provide lateral support to the catwalk as shown. Place three clips on either side of the flat cap.

Figure 56. Connecting flat cap clips to peak ring

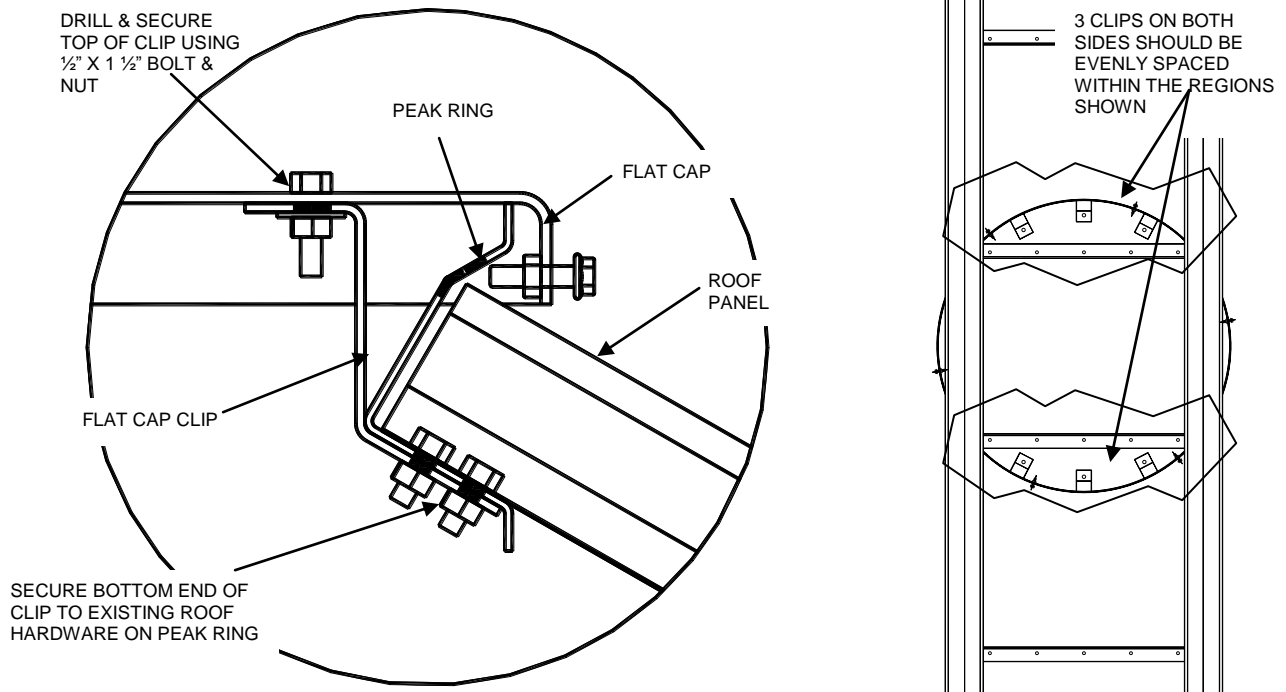

5.11.2 Structural Roofs

Two reinforcing brackets (provided) are installed underneath the flat cap. They utilize the same bolts that secure the peak support to the flat cap. The reinforcing brackets provide vertical and lateral support across the peak ring. They must be drilled into the compression ring as illustrated (flat cap not shown for clarity). Secure with 1/2" x 1 1/2" hardware.

Figure 57. Peak support to peak ring connection

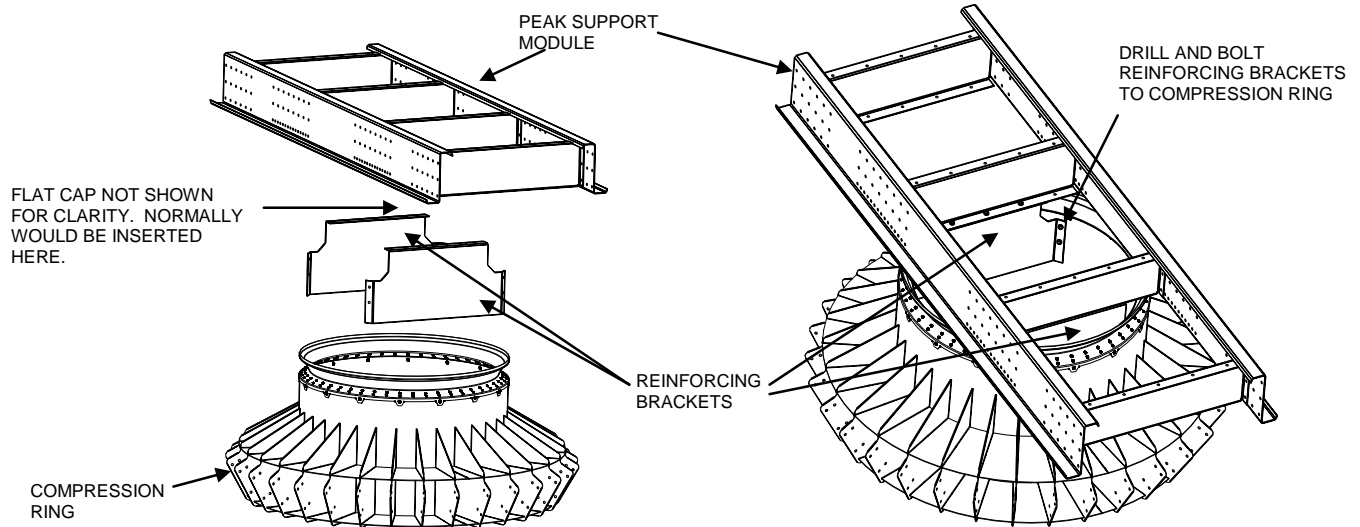

When positioning the catwalk onto the Peak Supports the catwalk Z-support beams should be sitting squarely on, and at right angles to, the Z-beams of the Catwalk Peak Support Module. Field drill 1/2" holes through the mating Z-flanges at all mating locations and secure with 1/2" x 1 1/2" bolts and nuts.

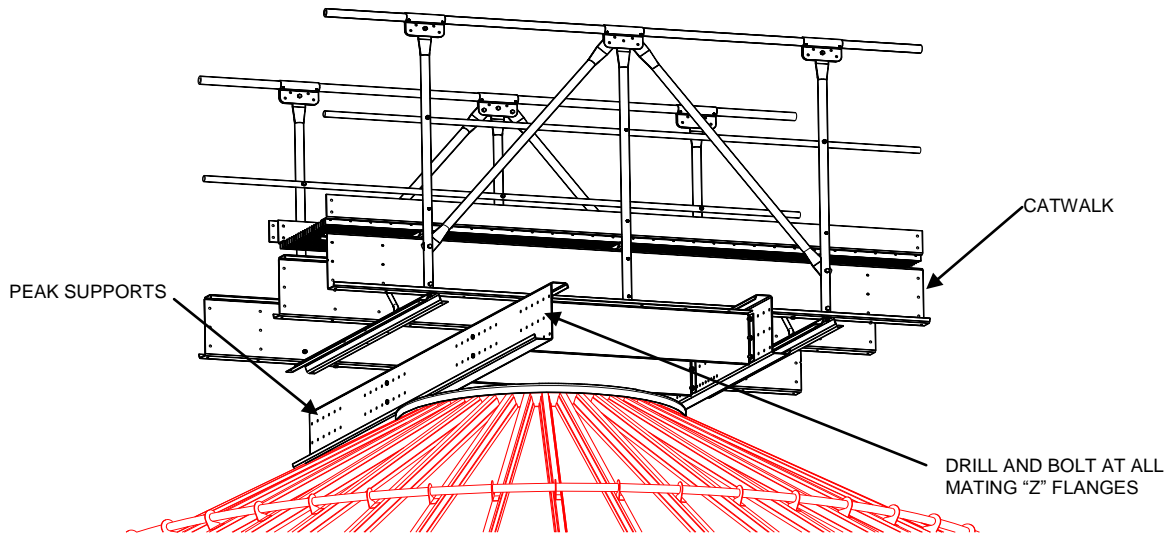
Figure 58. Positioning the catwalk on the peak supports

A hole can be cut through the flat cap top to accommodate spouting. If the spouting interferes with top or bottom catwalk hat sections at this location then they can be removed or cut to accommodate.

5.12. Catwalk Access

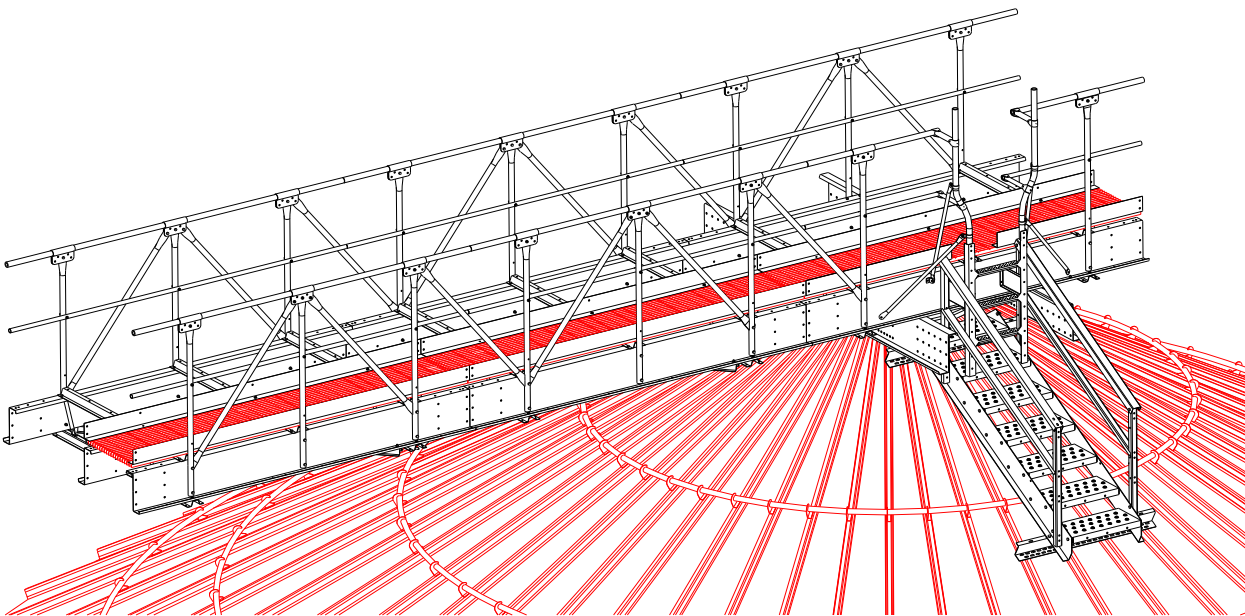
Figure 59. Catwalk Peak Access Module

Accessing the catwalk at the peak of the grain bin involves reaching the location utilizing roof cleats on the grain bin roof, or a roof stair system (shown), which are provided separately. Given the variety of components and options that could be present at this location, and the variety in the positioning of these components relative to each other, some field modifications and fitting will be necessary. Different options are explored below. Also, the components of the walkway may interfere with the hand rail components of the stair system. Local modification of interfering stair system handrail components may be required. This may entail repositioning the

upper handrail posts to a lower position along the stair stringers and shortening the handrail and mid-rails to accommodate. The stair stringer itself may also require shortening.

Figure 60. Catwalk Peak Access Module Positioning Options

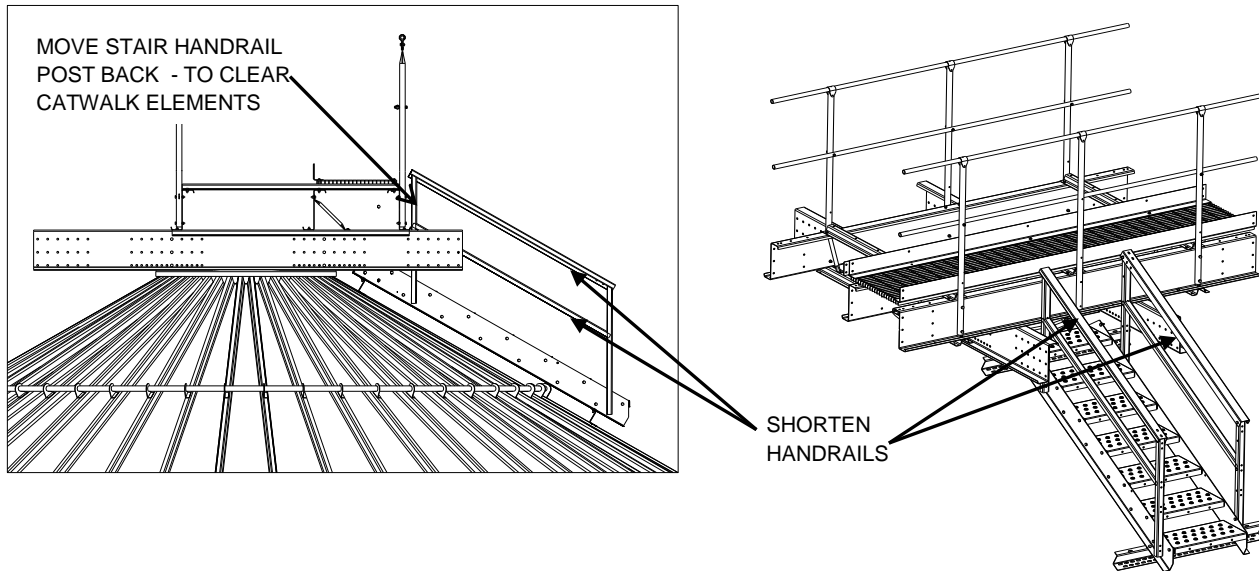

5.12.1 Ladder Positioning

At the peak location, the best catwalk access is likely from the side, on the walkway side of the catwalk. However access through the end of the catwalk is possible if the catwalk is terminating at the grain bin peak. A single 44" ladder section (234500) is provided to span from the roof cleats, or stair system to the catwalk walkway. In most cases the single ladder section is all that will be required. However an extra section may be required (must be ordered separately) if for example access is being made through the catwalk end and the catwalk is extending beyond the peak location by a significant amount. If more than one ladder section is required, additional support of the ladder rails may be required with the use of angles or tubes bolted along the ladder rails. An unsupported ladder rail segment should not exceed 60".

5.12.2 Securing the Top of the Ladder

The ladder section needs to be in a vertical position, or very close to it, and the back of the ladder rungs must clear any points of potential interference (such as the outward formed flanges of the catwalk Z-beams) by at least 7".

Access from the Side of the Catwalk

Standoff brackets (213373) are provided which can be attached to the Z-beams if accessing from the side, and which will provide the necessary clearance. The top ladder rung should also be positioned level with the catwalk walkway surface, which means that the bottom of the ladder section will likely need to be cut to fit. Some vertical positioning to accommodate the rung spacing at the top and the bottom may be necessary. Field drilling will be required to secure the standoff brackets to the Z-beams and to the ladder rails.

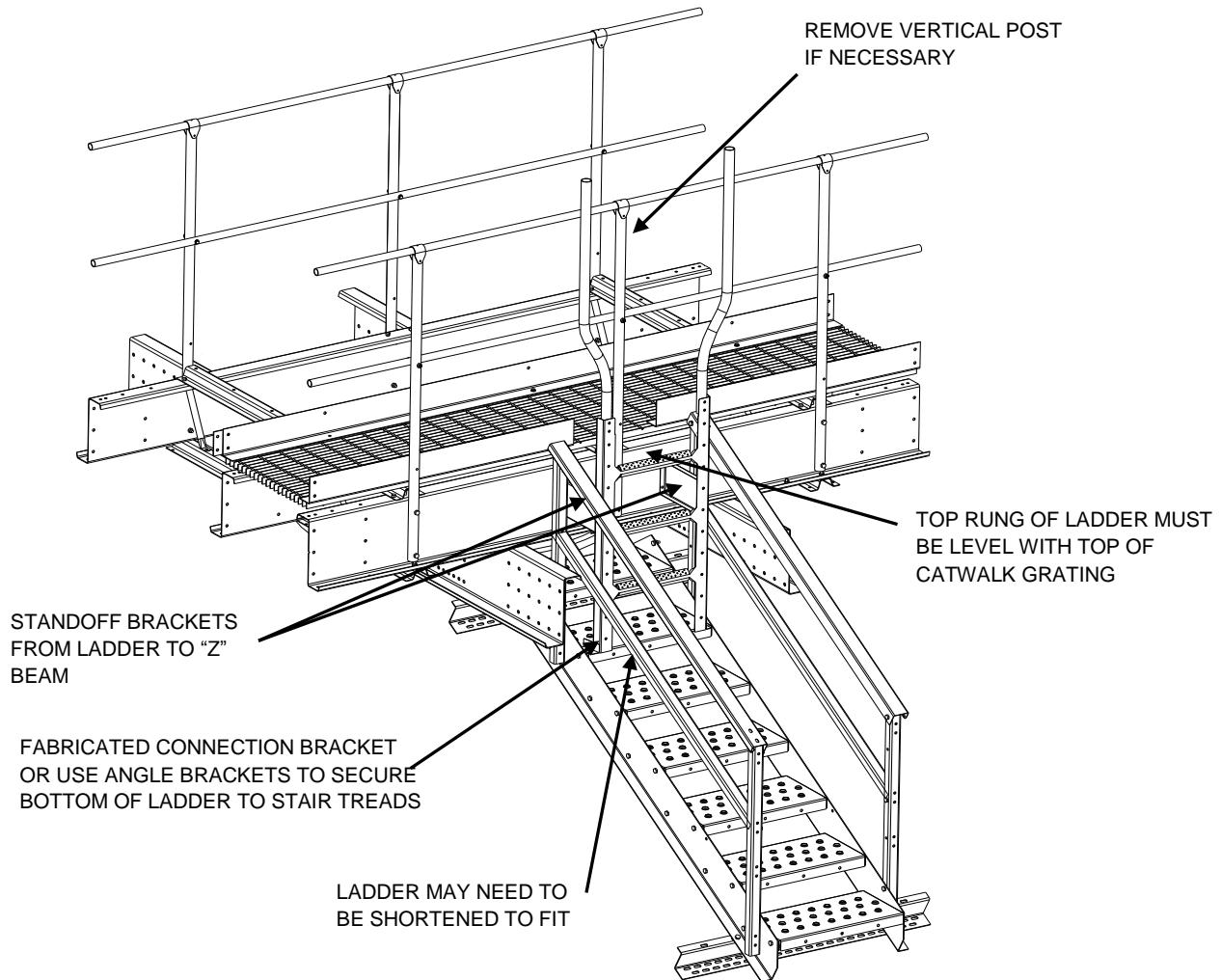
Figure 61. Access from the side of the catwalk**Access from the End of the Catwalk**

Two angle brackets (213409) have been provided that can be used to bolt into the ends of the two Z-beams on either side of the entry point, as illustrated. A surplus hat section can then be cut to fit between these same Z-beams. If a surplus hat section is not available a field manufactured section spanning between the Z-beams will be required. Drill and bolt the hat section to the angle brackets (hat section pointing inwards). The standoff brackets can now be bolted to the flanges of the hat section and support the upper end of the ladder. The timing should be such that the ladder is positioned at least 7" away from any interference behind and the top ladder rung is level with the catwalk grating.

Figure 62. Access from the end of the catwalk

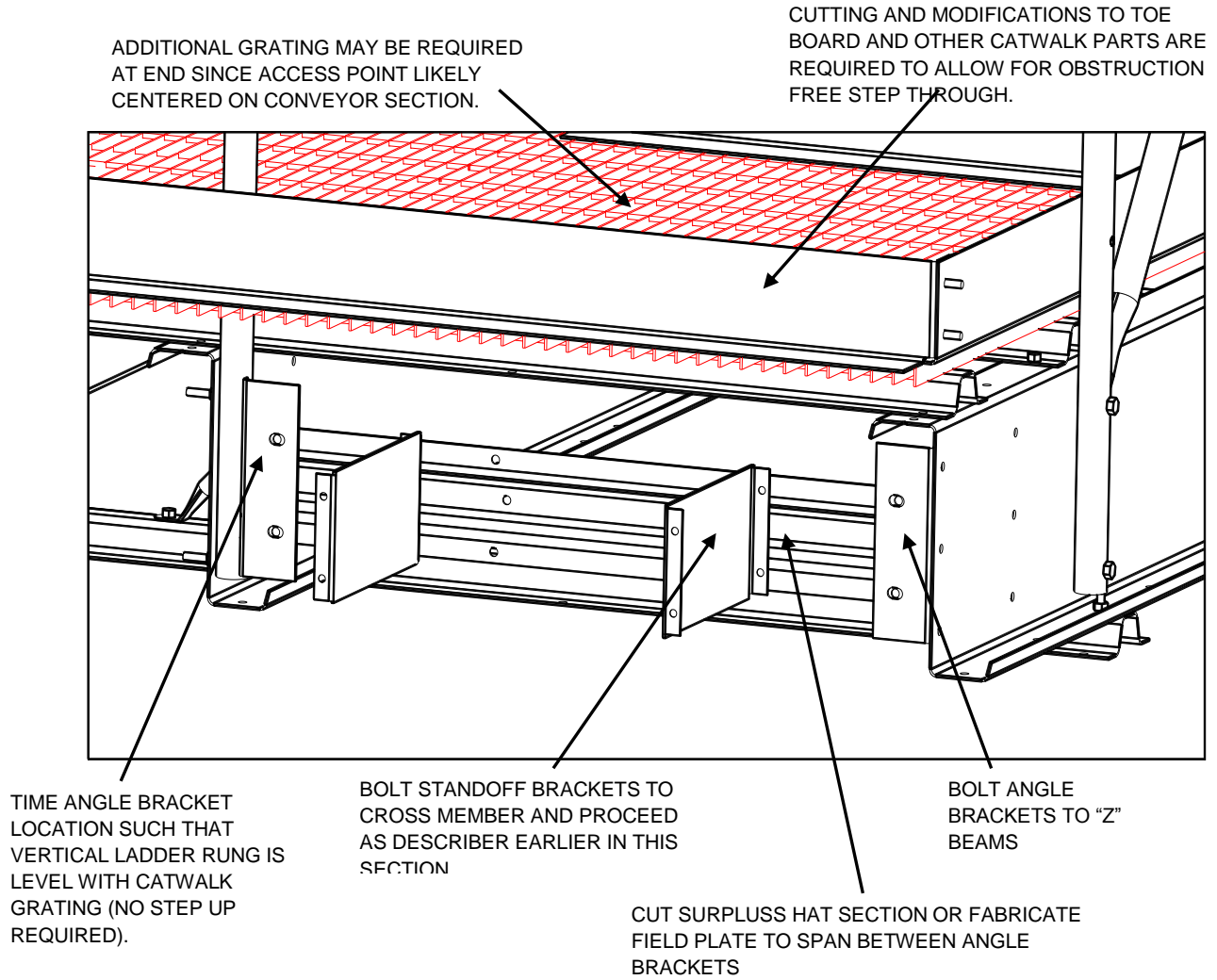

5.12.3 Securing the Bottom of the Ladder

The bottom of the ladder also must be secured. If utilizing roof cleats, the ladder can be secured to the flat side of the appropriate mating roof cleat utilizing a field fabricated connection plate as shown. The roof cleat will need to be field drilled to bolt to the connection plate. If the roof cleat is not positioned conveniently, it can be relocated down the roof rib to the correct location. If repositioned, field drilling of the cleat into the roof ribs will be required.

Figure 63. Mating to roof using fabricated connection plate

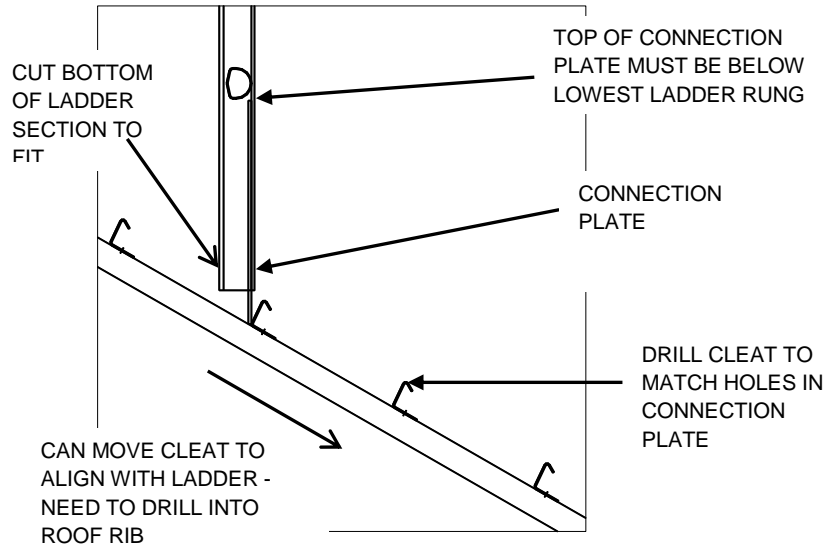
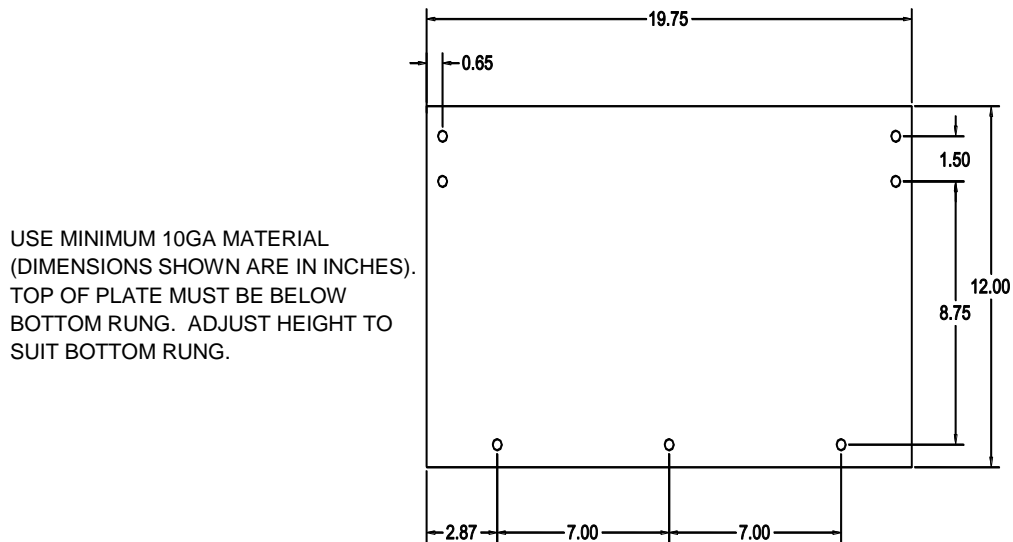
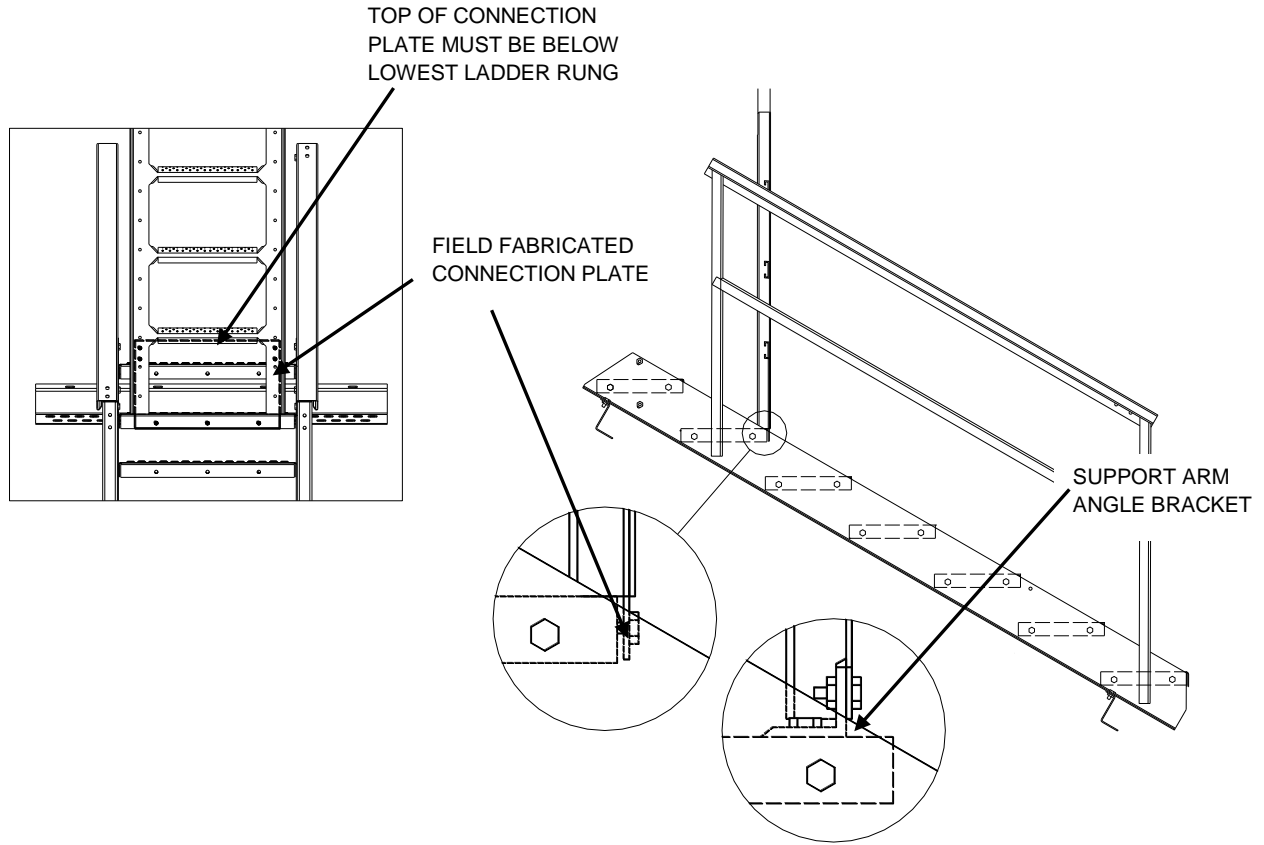

Figure 64. Fabricated connection plate



If mating to a Westeel roof stair system, the same field fabricated plate can be used to bolt to the front or back of stair treads to secure the bottom of the ladder. If the treads are not positioned ideally then field modification may be necessary to lengthen the standoff clip (by shimming), and/or reposition the connection plate relative to the stair tread (by shimming). Another option is use the small ladder support arm angle brackets (234518) or field fabricated bracket, to secure the ladder rails directly to the top surface of a stair tread. Field drilling of the ladder section rails to accommodate the hole positioning of the angle brackets or connection plate may be required.

Figure 65. Mating to roof stair using connection plate or support arm angle bracket

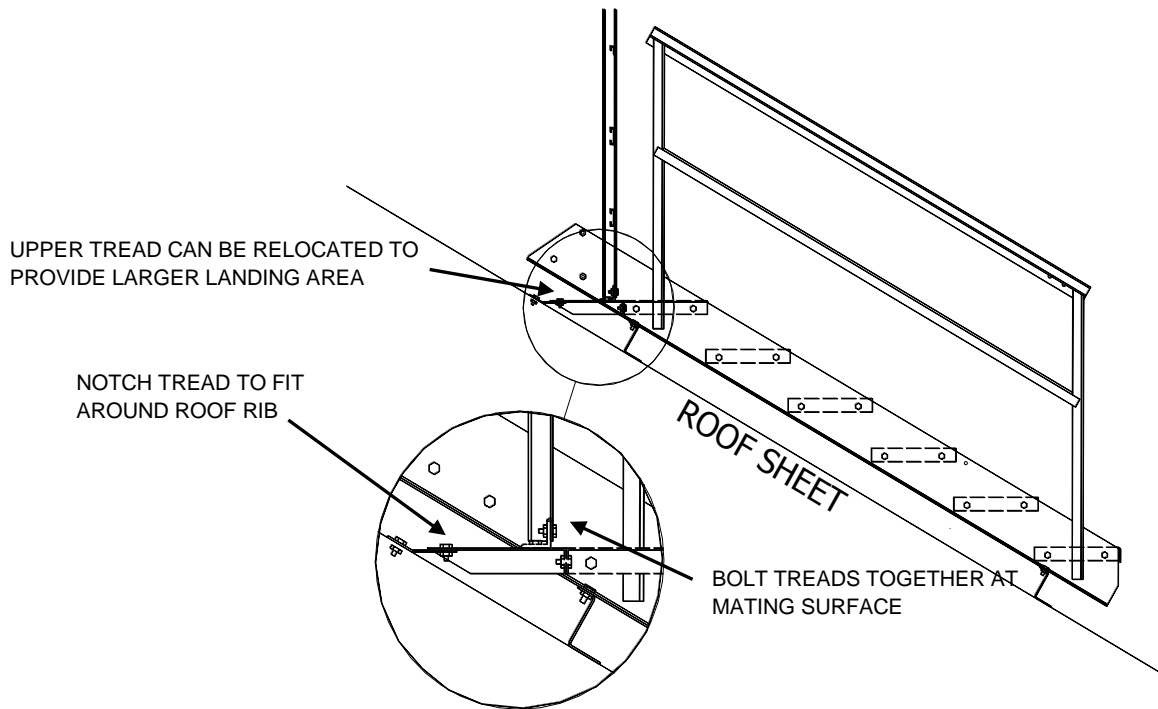

There are timing factors that affect the relative positioning of the access ladder to the roof stair (roof diameter, type, width and positioning of catwalk, roof ladder starting point, roof ladder package). If desirable, a roof stair tread can be lowered and bolted onto the next lower tread to create a larger landing area at the bottom of the vertical ladder. The front edge of the relocated tread will likely interfere with the roof ribs. The tread can be notched to accommodate the ribs. Once assembled the two treads should sit level with each other. The ladder can then be extended to mate with the combined treads.

Figure 66. Positioning the access ladder

5.12.4 Access Step

An access step is provided to bridge between the catwalk grating and the access ladder.

The distance between the top ladder rung and the grating is governed by codes that vary between jurisdictions. In North America the distance is 180 mm (7") minimum to provide toe clearance. In Europe the distance must be no greater than 75 mm (3"). The top rung of the ladder should be installed such that it is timed with the grating level. This is particularly important for the European version as the access step could be a point of interference if it is out of sequence. For this reason there are two different access step part numbers: one for North America (213062) and one for Europe (213068).

The access step can be used with both grating styles, and whether the point of access is through the side of the catwalk or the end of the catwalk.

When utilized with bar grating the upper portion of the access step sits on top of the grating and the side rests against the Z-beams when accessing the catwalk from the side. Along the top edge secure to the grating with 3/8" bolts and nuts (pilot holes will need to be drilled larger to accommodate). Use flat washers (235372) under the grating to bridge between grating bars. The lower end of the access step can be secured with self-drilling screws into the Z-beam. When accessing from the end of the catwalk the lower end of the access step may need to be supported between the ends of the Z-beams with a field fabricated support which can be timed with the support of the standoff brackets (as described earlier).

When utilized with a punched walkway and entering from the side, the walkway toe boards are cut away to permit access, thereby weakening the entrance point. The access step strengthens this area. Secure with self-drilling screws through the pilot holes along the top edge. The same applies when accessing the end of the punched walkway. The lower portion is attached in the same manner as described above for the bar grating.

Figure 67. Access step mounting

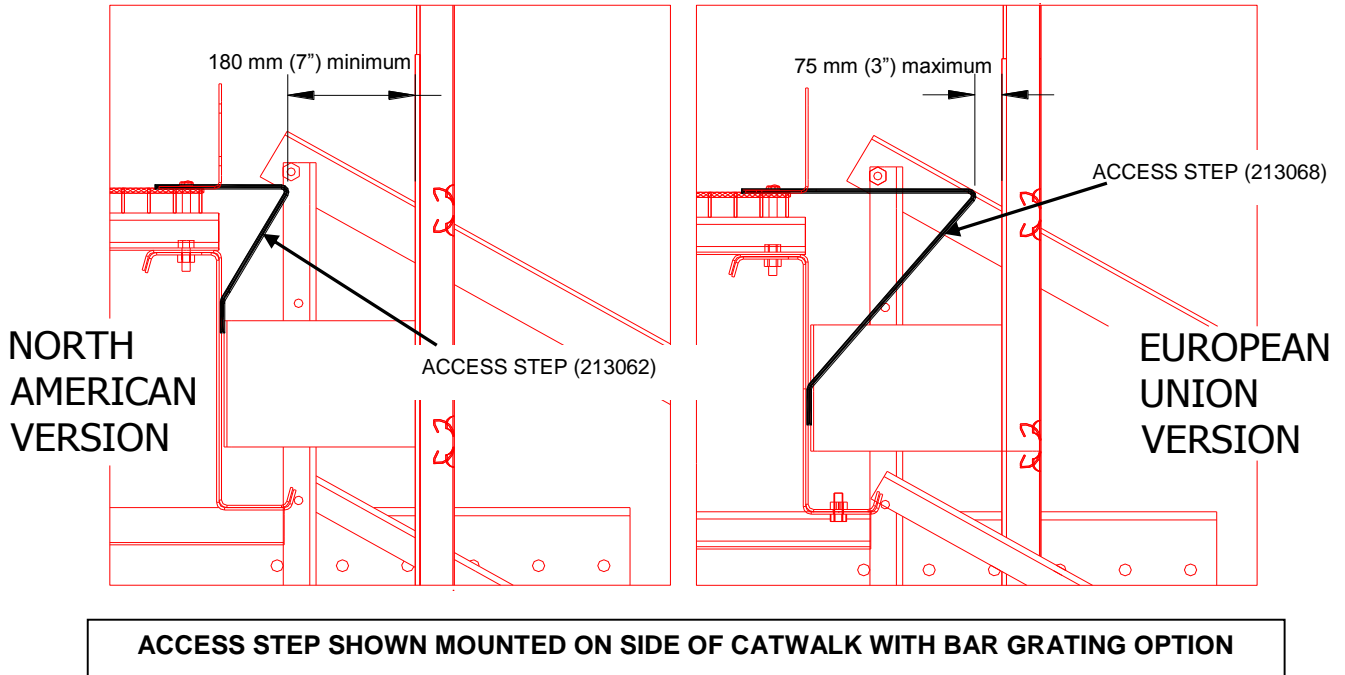

5.12.5 Bar Grating Walkway Considerations

The toe board will need to be trimmed at the point of access. Both of the free ends of the toe board on either side of the point of access must be secured to the bar grating. Drill holes at the free end and secure to the bar grating. Flat washers (235372) are provided to bridge across the grating openings underneath the grating to permit bolting. An optional access step (213062) is also provided. Enlarge the top 3 holes of access step (from $\varnothing 0.25''$ to $\varnothing 0.406''$) for $3/8''$ bolts and flanged nuts. The top end of the access step is secured to the entrance portion of the bar grating by bolting through the grating as just described above (field drill holes where appropriate). The lower end rests against the Z-beam. Secure into the Z-beam with self-drilling screws.

Figure 68. Securing the toe board to bar grating

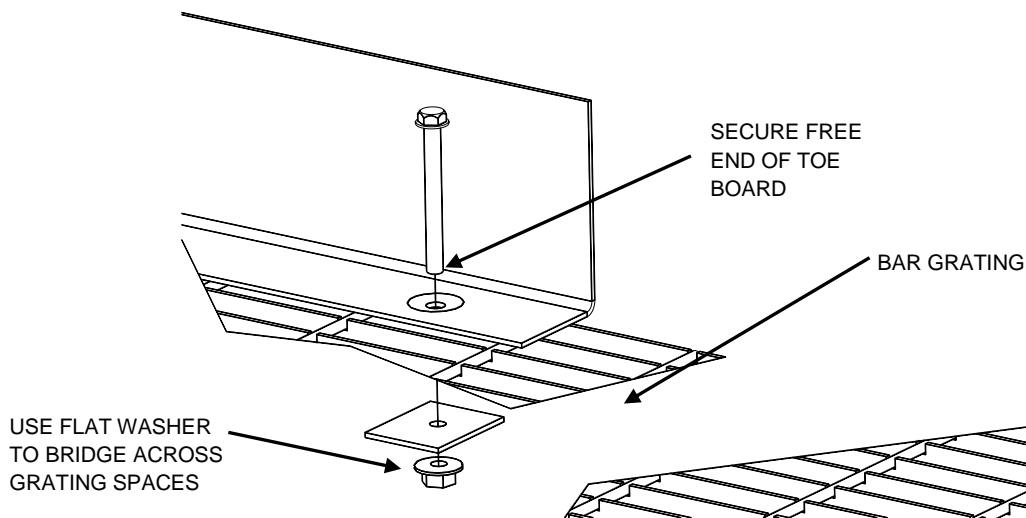

5.12.6 Punched Platform Walkway Considerations

The integral toe board on the side of the punched walkway must be cut way to permit access. Use the access step (213062) to reinforce the opening. Lay the access step on top of the punched platform at the opening such that the lower end is resting against the Z-beam. Secure at the top and bottom with self-drilling screws.

Figure 69. Connecting to a punched platform

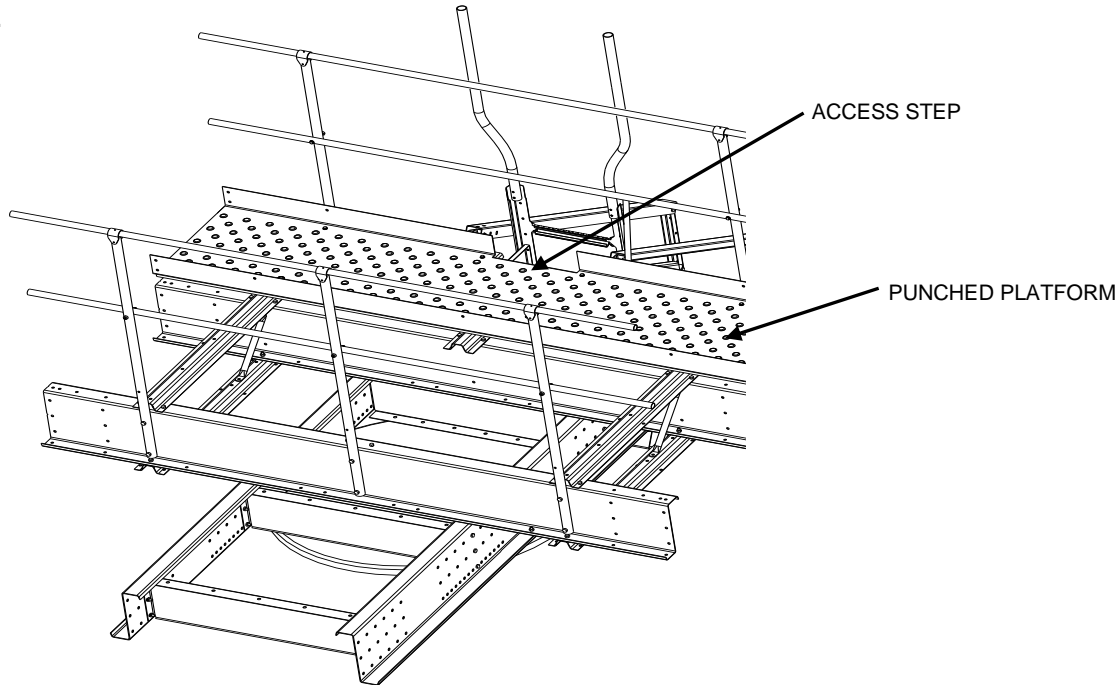

5.12.7 Ladder Pass-Through Rails

The ladder pass through rails (234505) bolt to the top second and third holes of the ladder side rails as illustrated. They are also secured with the use of ladder support arms (234504) and long braces (234176), which are attached to the pass through rails with ladder support arm clips (234517) as illustrated. The other end of the support arms need to be tied into structural elements on the catwalk such as Z-beams, toe boards, vertical posts, handrails, etc. This is usually facilitated with the use of support arm brackets (234518) which are secured to the structural elements. The positioning and securing of the above elements is a field requirement. Insure the pass through rails are secure.

Figure 70. Ladder to pass-through rails connection

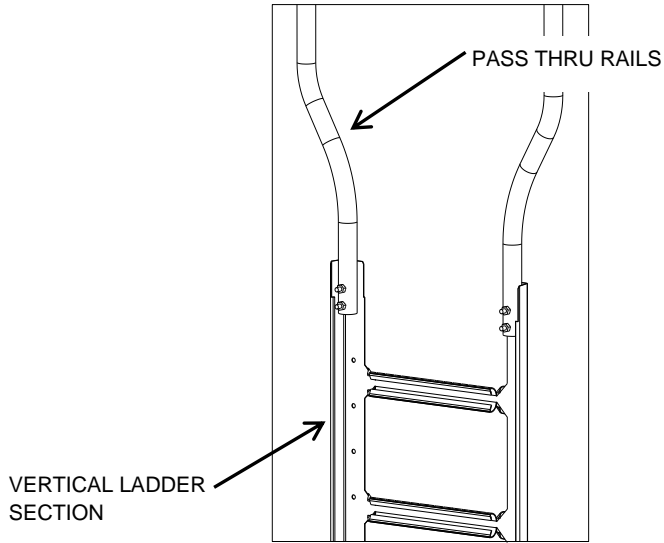

INSURE PASS THROUGH RAILS ARE SECURE BY USING SUPPORT ARMS AND CLIPS TO TIE INTO STRUCTURAL ELEMENTS.

Figure 71. Positioning and securing ladder pass-through rails

Place plastic end caps (234559) on the tops of the pass through rails.

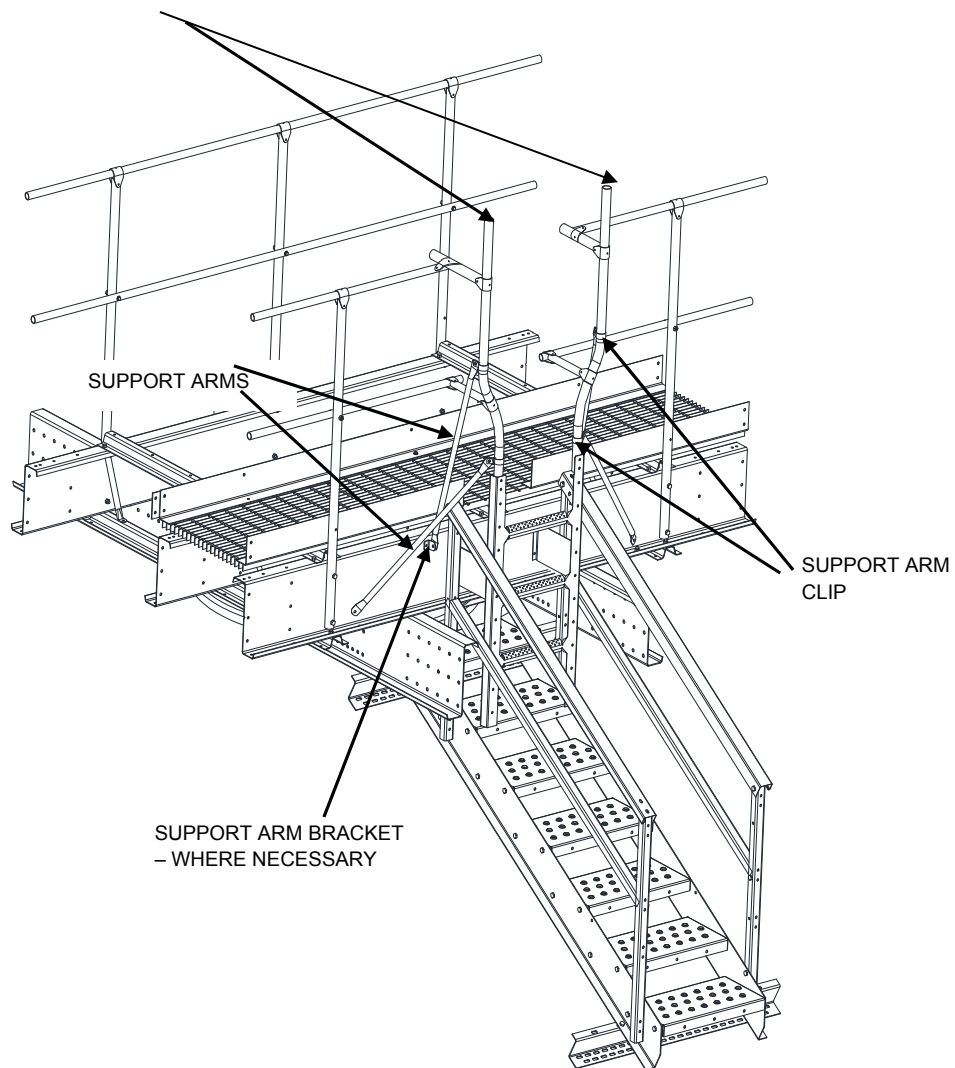

5.12.8 Catwalk Handrail Considerations

Ideally the point of access to the catwalk does not occur at a location where there is a vertical handrail post, but if it does, the post will need to be removed.

5.12.9 Catwalk Self-Closing Gate Installation

1. Cut a 27.5-inch opening in the midrail.
2. Cut an opening in the handrail with the following width:
 - 31" for heavy duty catwalk
 - 30.25" for standard duty catwalk

Note

The cut away sections of handrail and midrail will be used later to fabricate new short rail to post elements.

3. Position two angle sections (213063) to span between the handrail and midrail at the corner locations on both sides of the opening. The one side surface of the angle section faces the catwalk, the other faces the cut opening.
4. From the midrail cut away section, cut short piece to span between the midrail and the pass-through rail (234505). Make sure that the new short midrail butts into the midrail at a right angle. Secure the short piece to the midrail and pass-through rail using midrail corners (213031) and 0.25" self-tapping screws (157042).

Note

Do not fasten 0.25" self-tapping screws (157042) into the center hole of the two midrail corners before the angle sections are applied.

5. From the handrail cut away section, cut short piece to span between the angle section and the pass-through rail (234505). Make sure that the angle section is vertical. Secure the short piece to the handrail and pass-through rail using handrail/midrail corners (213029/213031) and 0.25" self-tapping screws (157042).

Note

Do not fasten 0.25" self-tapping screws (157042) into the center hole of the two handrail/midrail corners before the angle sections are applied.

6. Secure the top edge of the angle section to the handrail, see [Figure 72 on page 77](#):
 - a. For the side of the angle section facing the catwalk (213063): use a support arm bracket (234518) and 0.25" self-tapping screws (157042) to secure the angle section to the new short handrail piece.
 - b. For the side of the angle section facing the pass-through opening: fasten 0.25" self-tapping screws (157042) through the surface of the angle section, the handrail corner and the new short handrail piece.
7. Secure the lower portion of the angle section to the midrail using 0.25" self-tapping screws (157042) through the surface of the angle section, the midrail corner and the midrail.

Note

The connection at the handrail and midrail corners are made by 0.25" self tapping screws (157042).

Figure 72. Attaching the Angle Sections and Short Rails

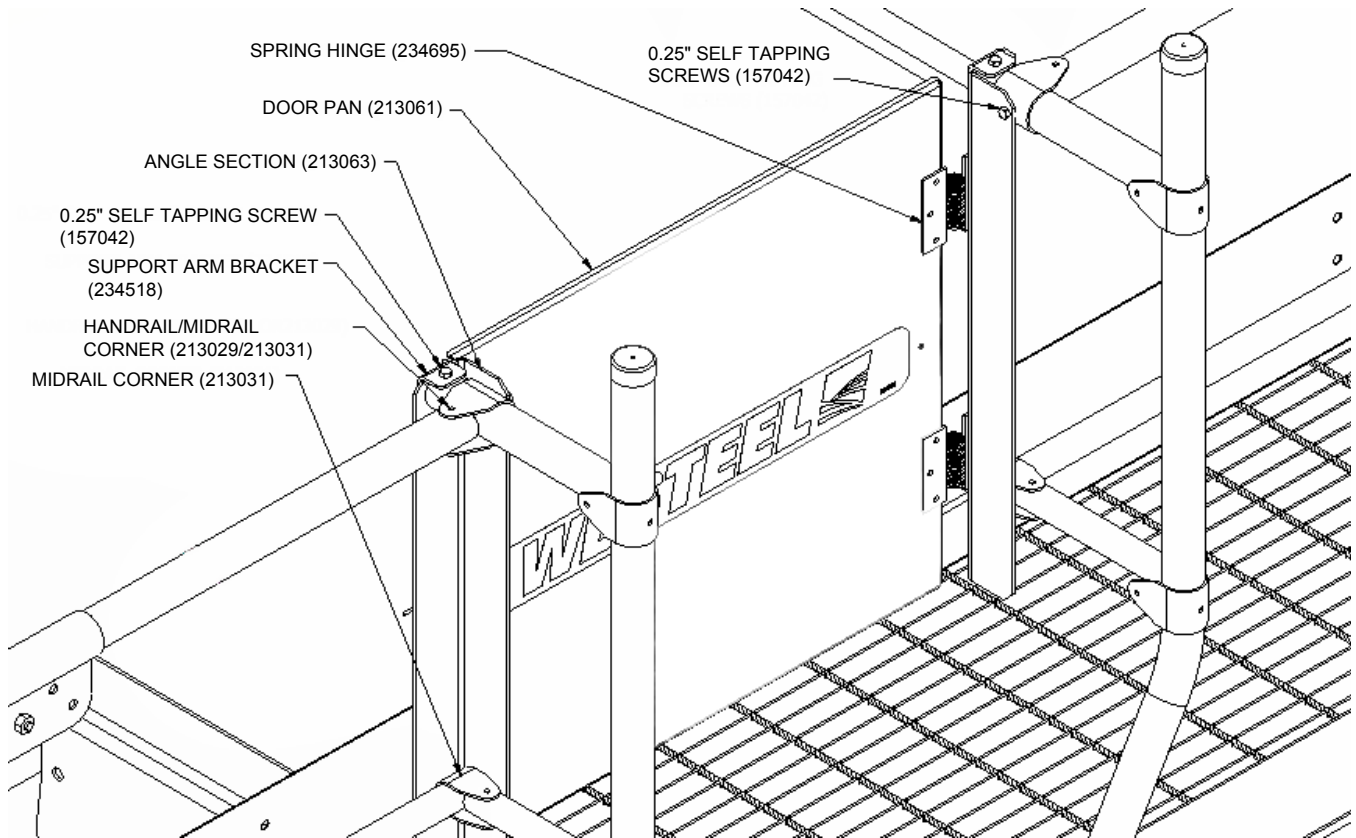
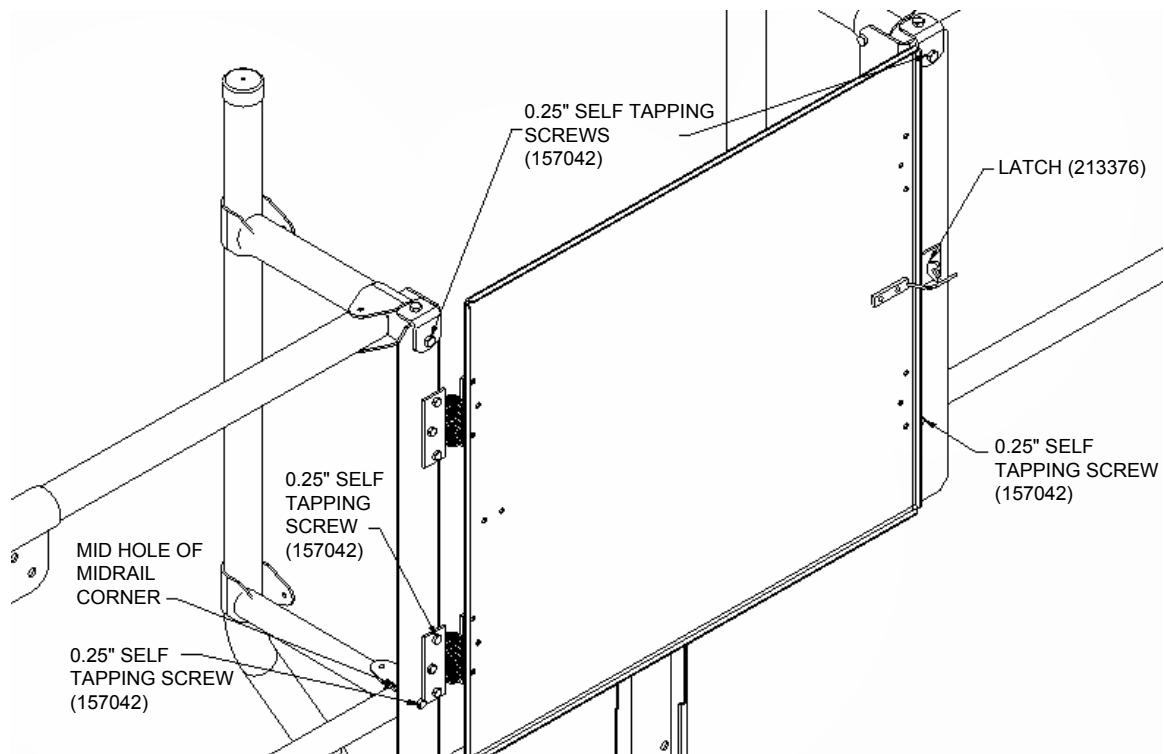

Figure 73. Mounting the Self-Closing Gate



8. Bolt the spring hinges (234695) and latch handle (213376, part 1 of latch) on the door pan (213061) using the 0.25" hardware (bolt PN: 235901 & nut PN: 154156) and #10-24 hardware (bolts PN: 154005 and nuts PN: 150008) provided, respectively, and make the door pan flange inside toward the catwalk.
9. Position door pan so that the bottom edge is not more than 19" (483 mm) from the walking surface of the catwalk. Mount the spring hinges (234695) on the other angle section using the six 0.25" self tapping screws (157042).
10. Put one or two spacer washers (193775) between the angle section and the latch lock for each of the four #10-24 hardware (154005 and 150008). Mount the latch lock (213376, part 2 of latch) on the angle section using the four #10-24 hardware (154005 and 150008) and make sure that the latch lock best matches the latch handle.
11. Make sure that the overlap between door pan and the angle section surface is not less than 0.5".
12. Adjust the spring hinge strength to your requirement.

5.12.10 Heavy Duty Catwalk Access Variations

The insertion of a peak access point in a heavy duty catwalk system remains essentially the same as described above. The diagonal brace tube(s) at the point of insertion will need to be removed. Heavier corner clips will need to be used to accommodate the heavier handrail tube.

5.13. Goal Post and Knee Brace Modules

Goal posts are the vertical structural supports that span from the eaves of the grain bins to the overhead catwalks. Knee supports are angled supports that are used to minimize the free spans of the catwalks.

The lower end of knee supports tie into the goal posts at a point just above the grain bin eaves and then angle upwards to tie into the catwalks. There are different configurations and combinations of goal posts, knee supports, and related bracing. Each configuration is dependent on the loads being carried, the allowable catwalk free spans, site specific requirements, etc. Consult specific site layouts to determine the appropriate layout.

Figure 74. Goal post and knee brace modules

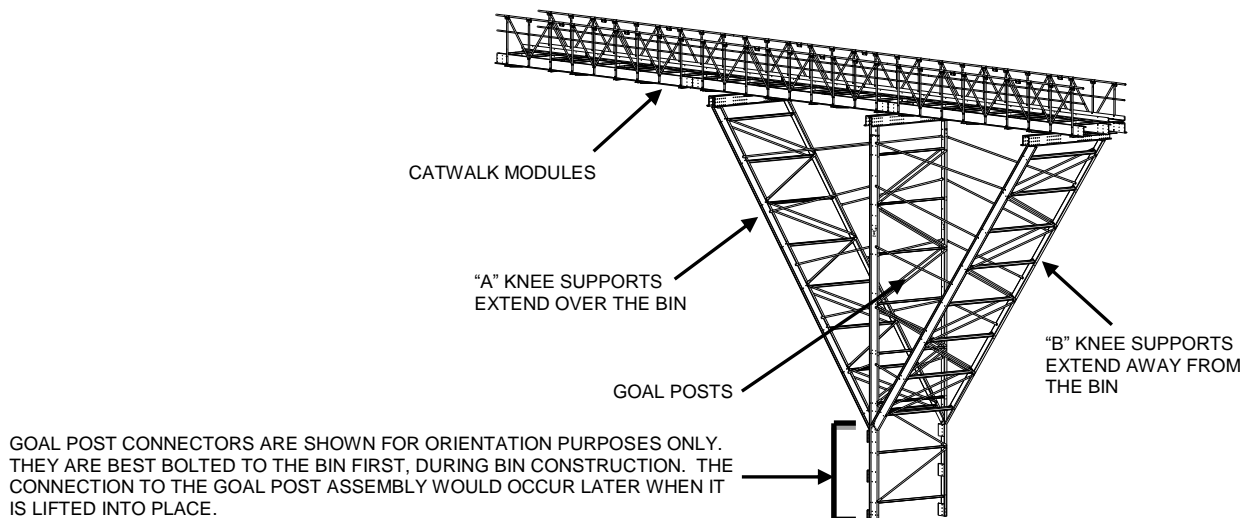

Two important variables are capacity and spacing. There are 44.5 kN (10,000 lb) and 89 kN (20,000 lb) capacity systems. The two vertical goal post supports can be located on adjacent uprights (single spacing), or spaced two uprights apart (double spacing). The bin layouts and their angular positioning must match the selected spacing. Check the site specific layouts. The following are the goal post options presently available.

- 44.5 kN (10,000 lb) capacity on adjacent uprights – from 4.6 m (15') through 33m (108')
- 44.5 kN (10,000 lb) capacity spaced 2 uprights apart – from 16.5 m (54') through 33m (108')
- 89 kN (20,000 lb) capacity on adjacent uprights – from 9.1 m (30') through 20.1 m (66')
- 89 kN (20,000 lb) capacity spaced 2 uprights apart – from 16.5 m (54') through 33 m (108')

5.13.1 Connection to the Grain Bin

Goal posts connect into the grain bin uprights using upright connectors which bolt into the center section of the upright hat sections utilizing the same hardware that connects the uprights to the grain bin walls (3/8" x 1 1/2" hex bolts). For this reason **the best time to attach the upright connectors is at the same time the uprights are bolted to the bin.** If retrofitting an existing bin, the appropriate connection points will need to be disassembled to facilitate the addition of the upright connectors. Ensure the bin structure is capable of supporting the loads.

Upright connectors are angled to match the curvature of the bin so there are unique connectors for every bin diameter. Make sure the connector part numbers match the bin diameter in question.

The timing and location of upright connectors is also important. Since the upright connectors are potentially being installed well in advance of any subsequent catwalk considerations, consult the site layouts to insure that later repositioning of the connectors is averted.

Figure 75. Placement of upright connectors

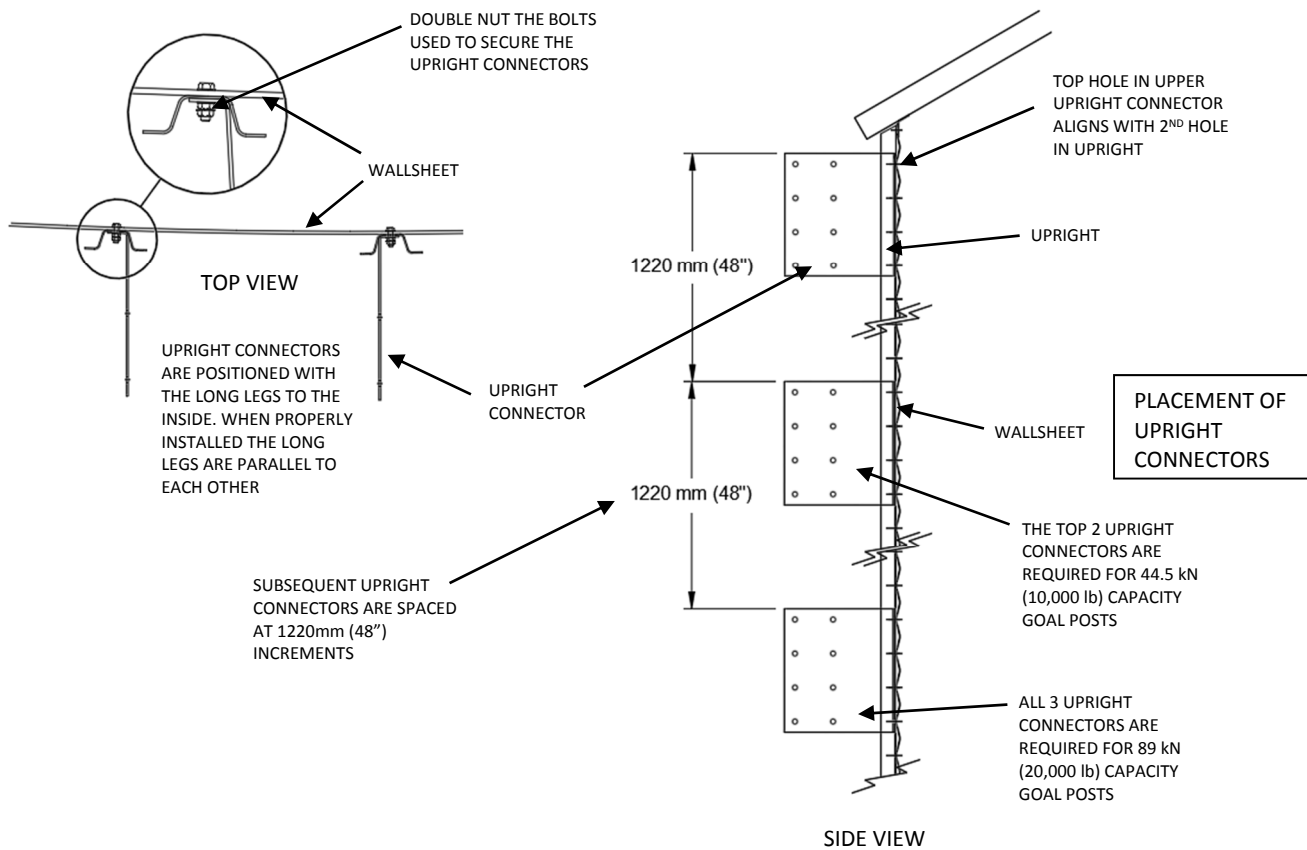

For 44.5 kN (10,000 lb) capacity connections there are two upright connectors per upright (See [Figure 75 on page 79](#)). For 89 kN (20,000 lb) capacity connections there are three upright connectors per upright. In both cases the top hole in the upper upright connector aligns with the second bolted hole in the mating upright as illustrated. The next lower upright connector is then positioned 1220 mm (48”) lower (measured from top of connector to top of connector) on the upright and bolted in. The third upright connector (for 89 kN (20,000 lb) capacity connections only) is positioned another 1220 mm (48”) lower (again measured from top to top) and bolted in.

Note

All bolts used to make the upright connector connections should be double nutted such that the outer nut serves as a jam nut.

5.13.2 Goal Post Assembly

The goal posts are best assembled separately and then hoisted into position as an assembled unit. Therefore attention to the orientation and timing of mating components is essential to prevent assembly errors. When the goal posts are eventually attached to the upright connectors the flanges on the vertical Z-columns are positioned on the outside of the upright connectors (see [Figure 76 on page 80](#)). Therefore the flanges on the Z-sections that are closest to the bin must point away from each other (this is also the narrower flange). This means that one of the pair of vertical columns that make up a goal post assembly must be flipped end to end. To facilitate assembly a square orientation hole is punched on each end of the vertical Z-columns, on the wider flange. When properly assembled, the flange on the vertical Z-columns with the square holes should be furthest away from the bin and pointing towards each other.

Figure 76. Goal post to bin assembly

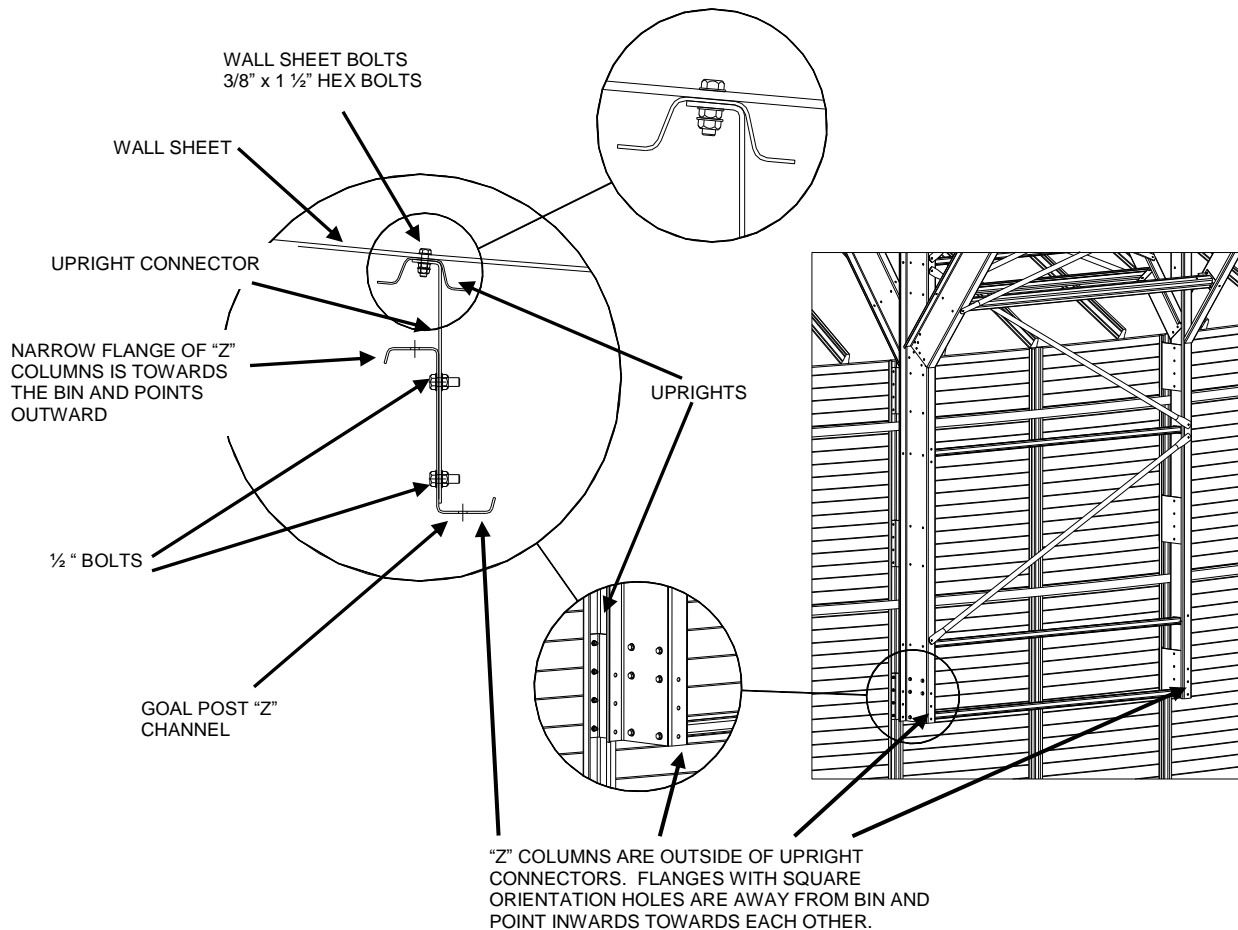

Therefore, when assembling the goal posts, first position the vertical Z-columns in a flat area with the correct orientation to each other. Use the square orientation holes to aid in this process. It is recommended that the wider flanges with the square holes are pointing upwards and with the flanges pointing towards each other (see [Figure 77 on page 81](#)). The balance of the goal post assembly consists of bolting on horizontal hat sections at regular intervals and tubular cross braces along the length of the goal post.

Figure 77. Goal post assembly

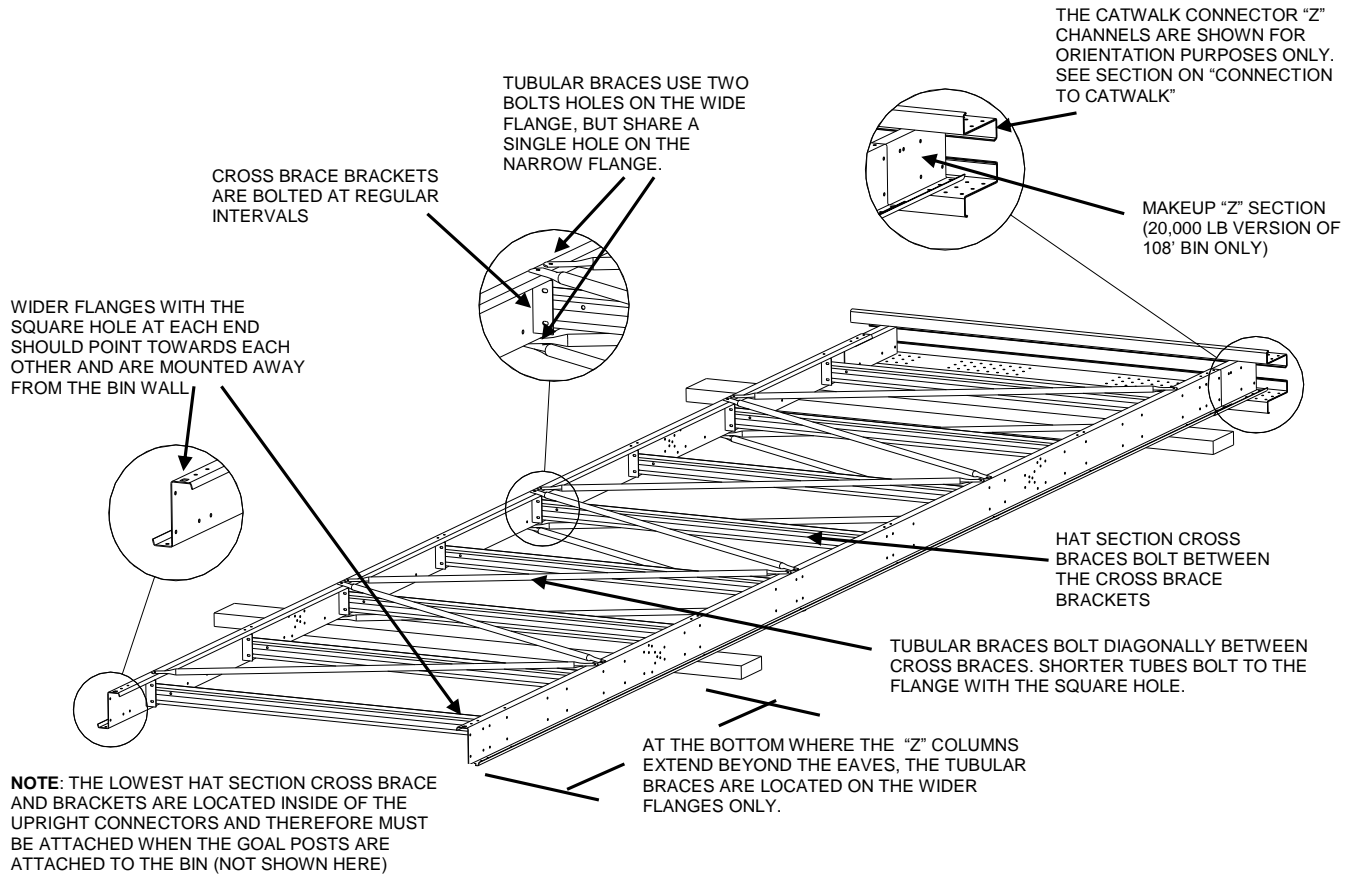

Hat section cross braces are bolted horizontally between mating vertical Z-columns utilizing short cross brace brackets. The brackets are bolted to the inside surface of the Z-columns first and then the hat section cross braces are bolted on as illustrated. The hat sections are located at regular 60" intervals along the length of the Z-columns. There is a pair of holes at these locations. These holes should not be confused with the tubular brace holes which are also located in the center web portion of the Z-columns. The lowest hat section will interfere with the eventual connection to the upright brackets and must be attached after the goal posts are assembled to the bin. Consult specific site layouts for clarity on the positioning of parts.

Tubular braces span diagonally along the length of the Z-columns as illustrated. There are two lengths. The shorter braces span between the wider flanges that are pointing inwards. The longer braces are on the narrower flanges. On the wider flanges pointing inwards the tubular braces have a separate bolt hole location at every connection. On the narrow flange pointing outwards the tubular braces share a single bolt hole where they meet. On the lower end of the assembly where the goal posts would extend below the eave of the bin, the tubular braces are only located on the wider flanges that are away from the bin.

Note

The Z-columns for the 89 kN (20,000 lb) version of the 108' diameter bin only consists of two pieces due to the excessive length. To extend the column insert the short makeup Z-section into the long Z-column as indicated in [Figure 77 on page 81](#) and bolt together.

5.13.3 Knee Support Assembly

As shown in [Figure 78 on page 82](#), Knee Supports come as “A” (bin side) or “B” (away from bin) and both attach to the goal post at their bottom ends near the eave. Their assembly is similar to the goal posts except that the square orientation holes are in the narrower flanges.

Figure 78. A and B Knee Supports

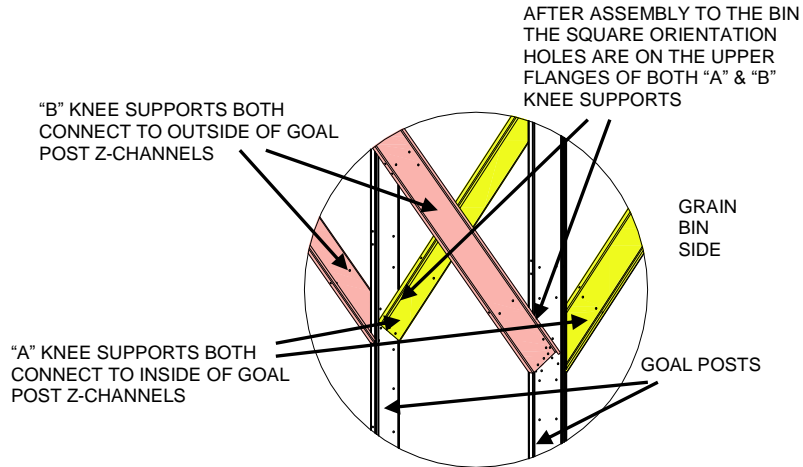
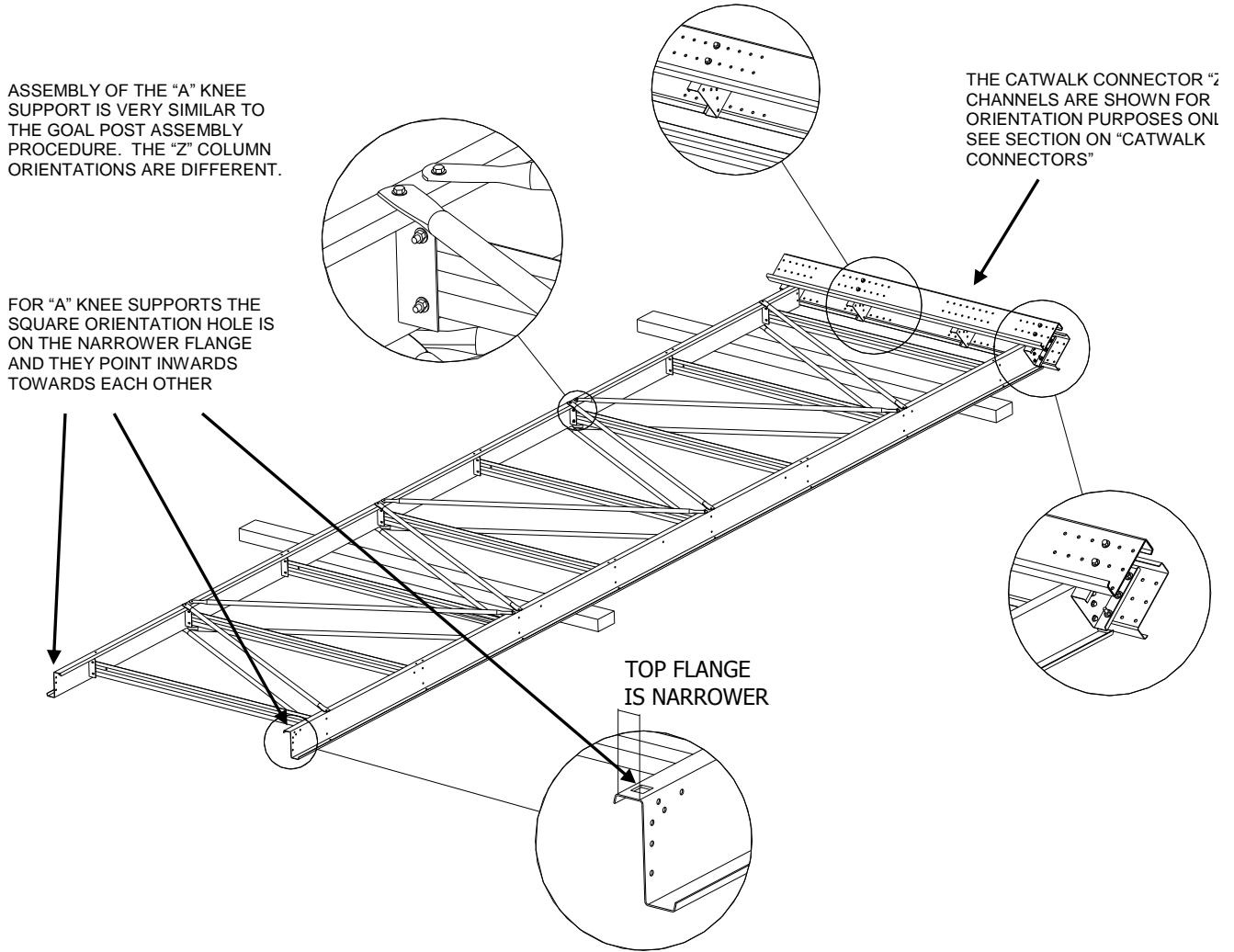
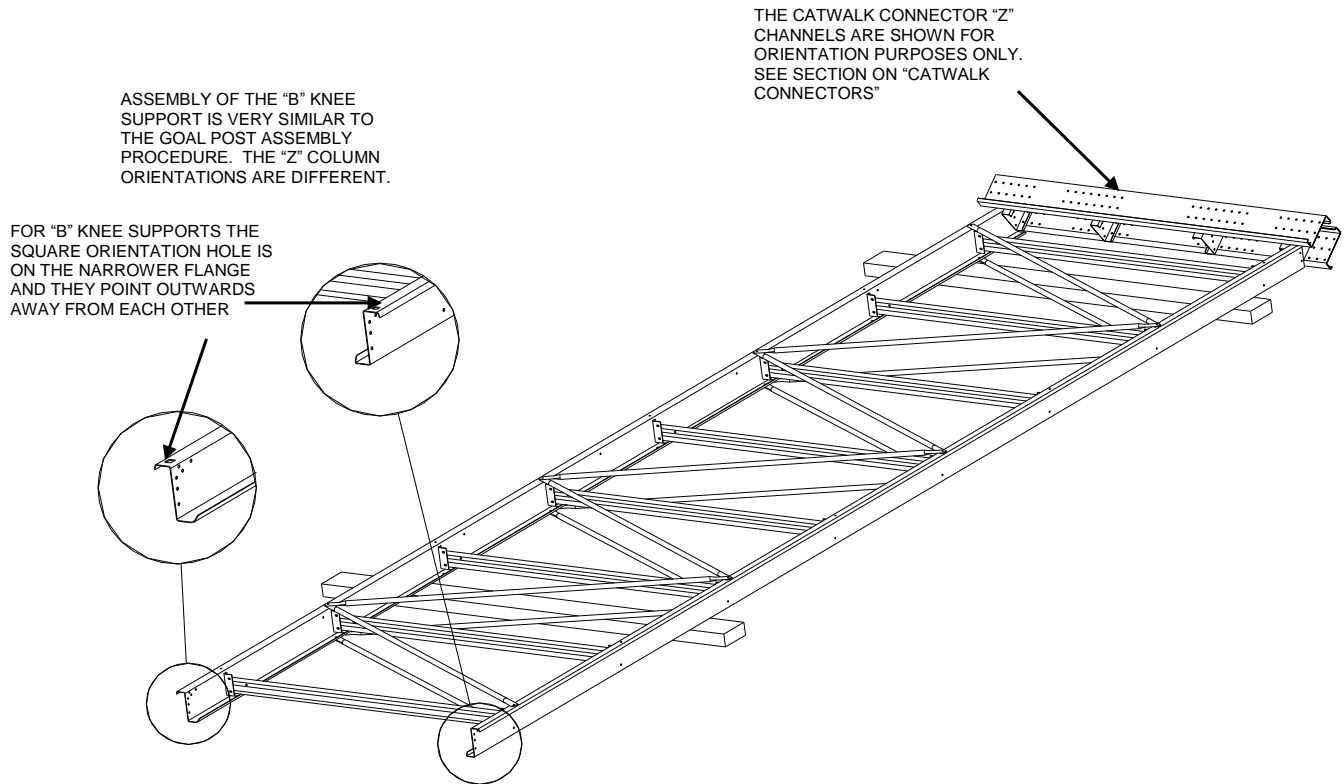

Figure 79. “A” Knee Support



Note

All Z-Channels are identified with part numbers either etched or on a printed label to identify them. See the charts at the back of this manual for a list of parts.

Figure 80. “B” Knee Support

5.13.4 Catwalk Connectors

The connection to the catwalk is made using the same Z-channels that are used at the peak ring support location except that they are attached to the top of the goal post and knee supports. The orientation of the Z-channels and upgrade methods are similar. A review of the Peak Ring Support Module is recommended.

When making a standard connection at the upper end of a goal post ([Figure 81 on page 85](#)), position the Z-channels (213401) such that the wider Z-flange is located at the bottom and pointing outwards. There are multiple hole locations within the Z-channels to accommodate site specific positioning requirements. Bolt the Z-channels to the goal post columns using a suitable set of holes. When mating to a goal post assembly that is attached to adjacent uprights (i.e. single spaced uprights), the inner hole groupings should be utilized. When mating to a goal post assembly attached to uprights spaced 2 apart then the outer hole groupings should be used.

In some cases involving large vertical load transfers the Z-channels will be required to be a double section. Two mating "Z channels, (the original Z-from above and the corresponding laminate (213402)) will nest together to increase the strength as illustrated in the Peak Ring Support Module and as illustrated in Figure M8.

The mating Z-channels are then further strengthened by inserting and bolting a spacer bracket in between. When mating to a goal post assembly attached to adjacent uprights, the spacer brackets should be attached at the outer hole groupings, one at either end. When mating to a goal post assembly attached to uprights spaced 2 apart then the spacer brackets should be attached to the inner hole groupings, one within each grouping (as illustrated in Figure M8). Choose the holes so the spacer brackets are roughly equally spaced with goal posts.

Figure 81. Goalpost to catwalk connection

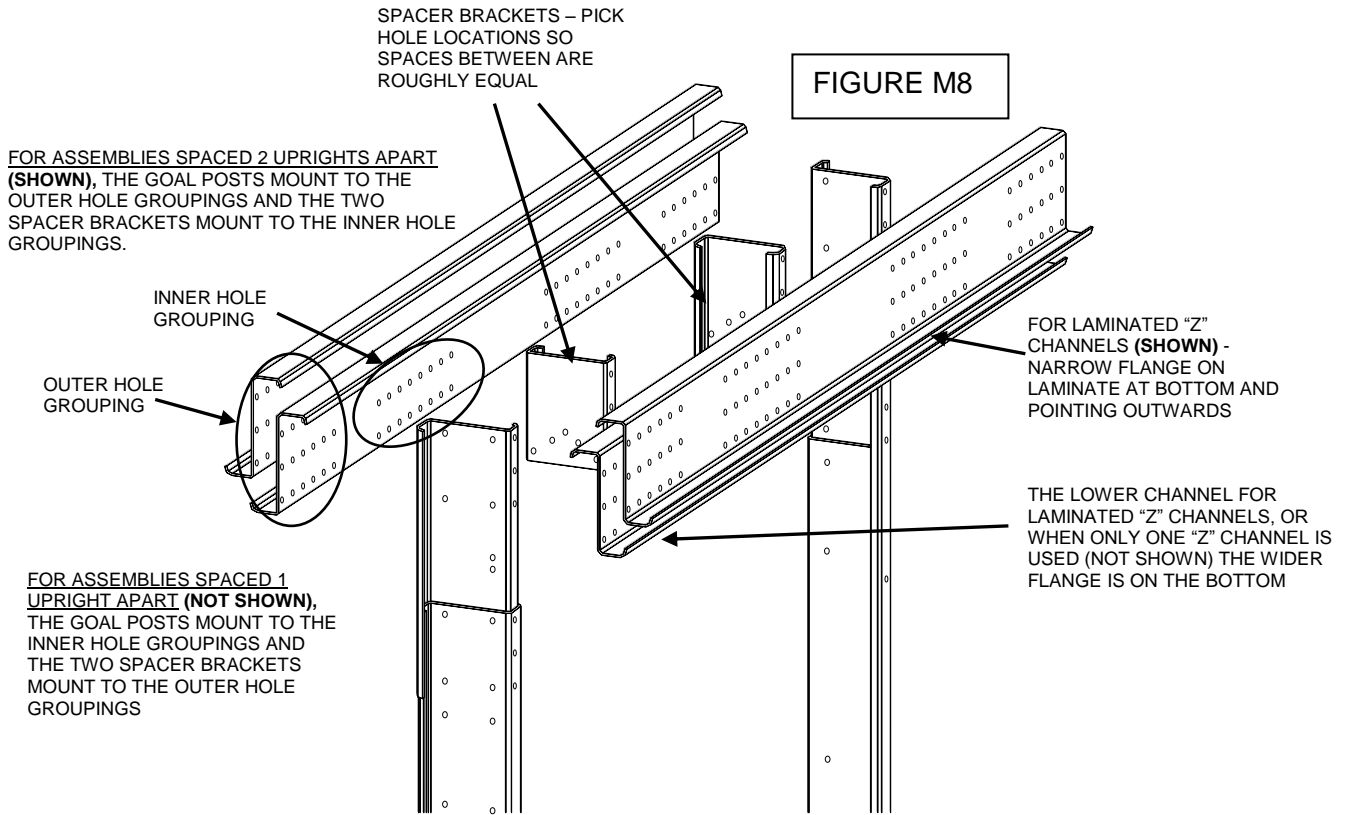

The same Z-channel configuration is also used for connecting the knee supports to the catwalk, only now the spacer brackets are also used to make the connection between the knee support Z-columns and the Z-channels as illustrated (see [Figure 82 on page 85](#)). First bolt the spacer brackets to the ends of the knee support Z-columns in the correct orientation. Then bolt on the Z-channels using the same bolt hole locations as selected for the goal post attachments.

Figure 82. Knee support to catwalk connection

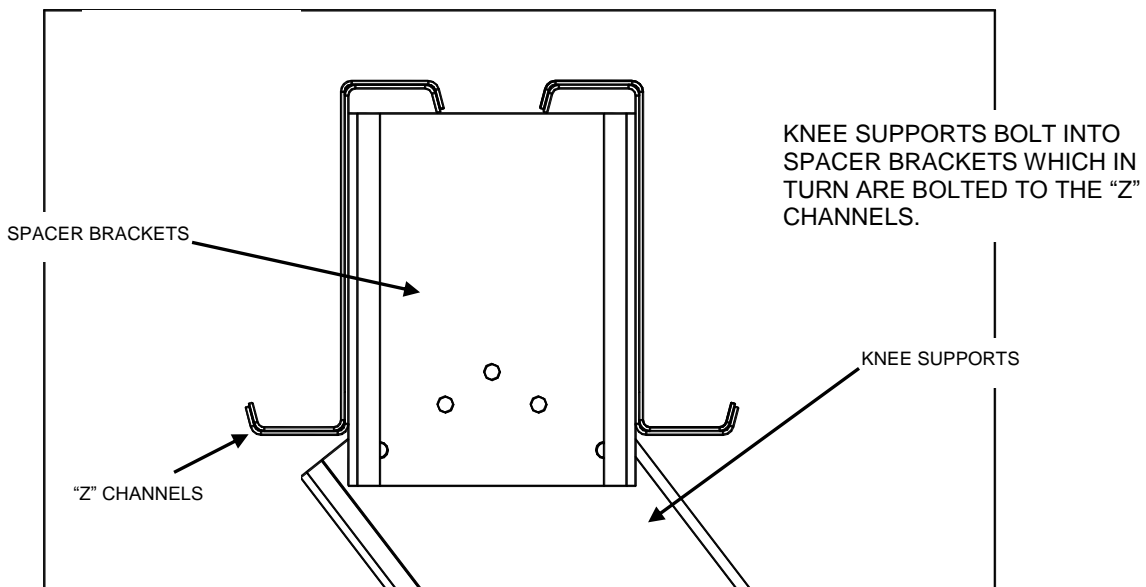

As with the Z-channels used for the goal post location, the channels can be strengthened with the addition of a laminate. Also the channels must be strengthened with the insertion of spacer brackets in between the Z-channels within the hole groupings not already occupied by the attachment to the knee supports (see [Figure 83 on page 86](#)).

Figure 83. Strengthening Z-channels by lamination

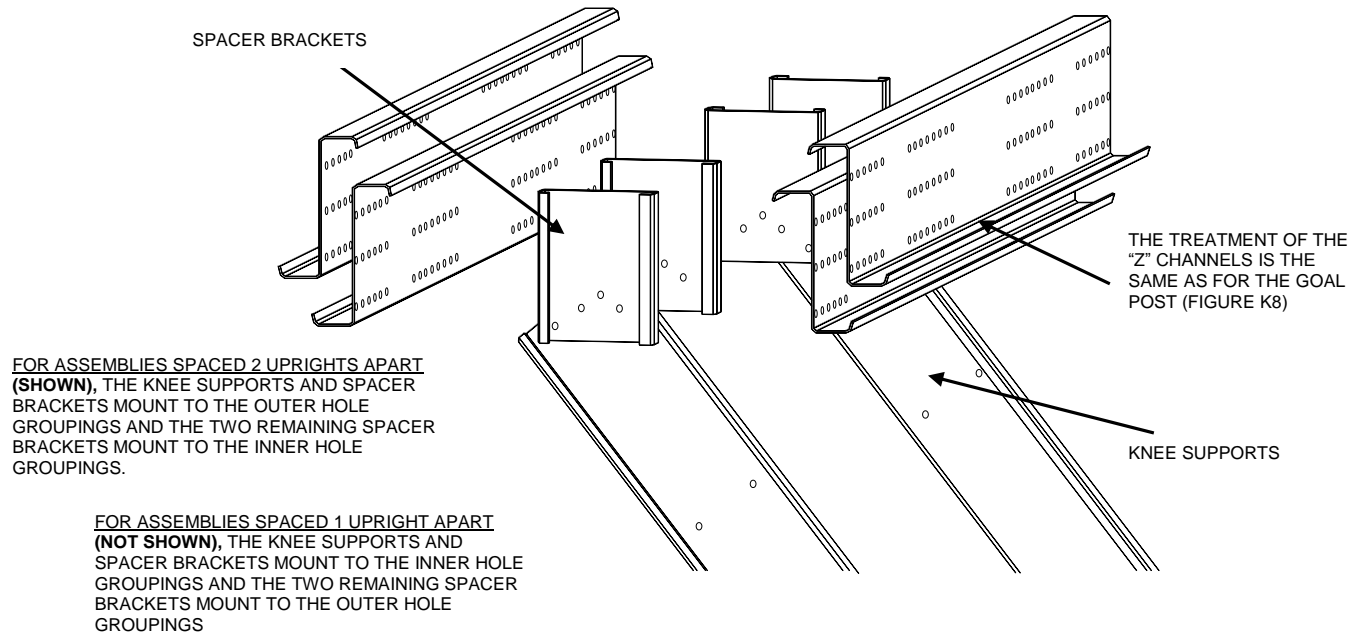

Finally, when connecting to the catwalk, the catwalk Z-support beams should be sitting squarely on, and at right angles to, the Z-channels of the above goal post and knee brace assemblies. If there is interference with any of the hat section braces on the bottom of the catwalk, then these hat section braces can be removed. Field drill $\frac{1}{2}$ " holes through the mating Z-flanges at all mating locations and secure with $\frac{1}{2}$ " x $1 \frac{1}{2}$ " bolts and nuts.

5.13.5 Connecting Goal Posts and Knee Supports

Orientation of the various Z-columns with respect to each other is critical. If interference occurs when making the following connections then the original assemblies may be wrong.

When assembled to the goal posts **the "A" knee supports are positioned such they are on the inside of the vertical Z-goal post columns.** Conversely **the "B" knee supports are positioned on the outside of the vertical Z-goal post columns.** Note that in both cases the narrow flanges with the square holes are facing up.

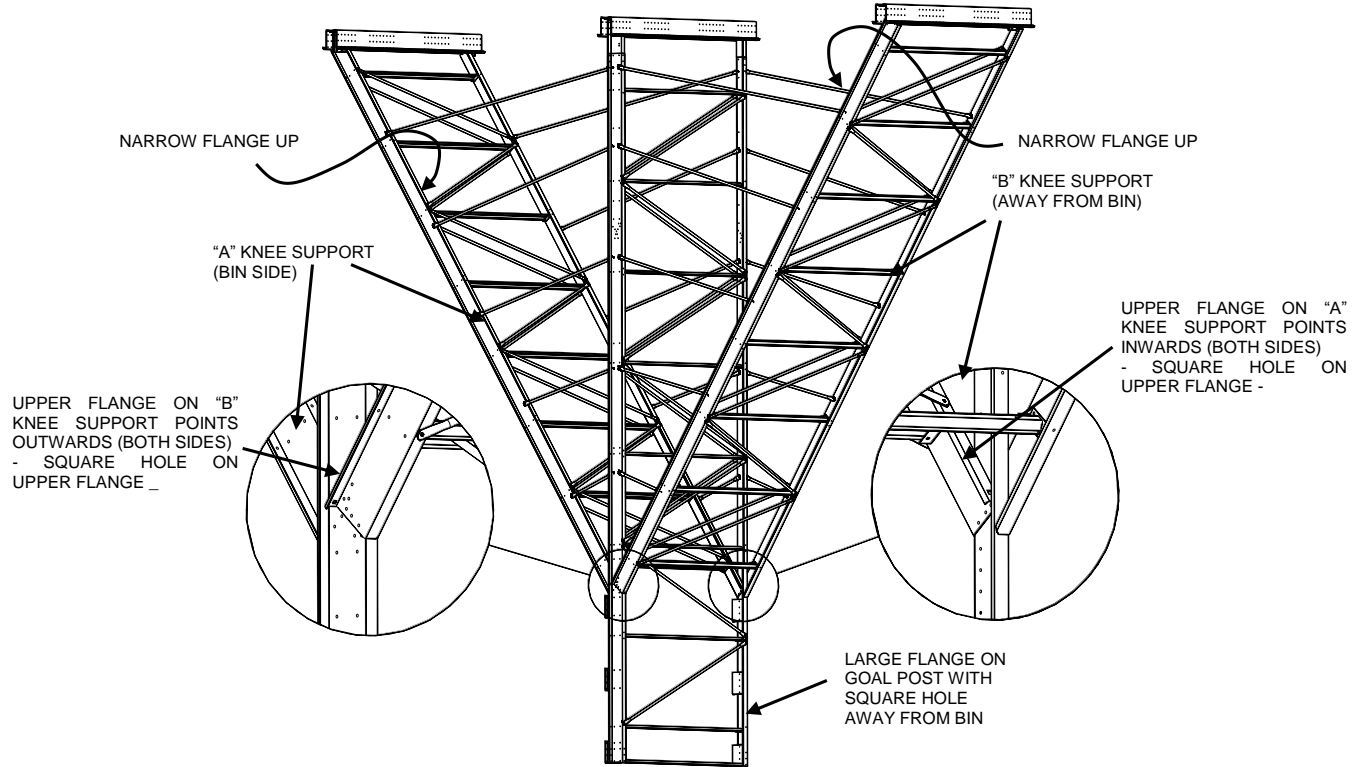
Figure 84. Connecting the A and B knee supports to the goal post column**Important**

There is a square orientation hole in both ends of the two knee support columns. For both “A” and “B” support columns the square holes identify the smaller flange and should be positioned such that they are on the upper flange. For the “A” knee support columns, the flange with the square holes should be pointing towards each other. For the “B” knee support columns, the flanges with the square holes should be pointing away from each other, or outwards

The assembly of the knee supports to the goal posts occurs at the bolt locations in the goal posts just above the eave of the grain bin. When assembling both an “A” and “B” knee support to a goal post assembly, there are shared bolt holes as illustrated ([Figure 85 on page 88](#)) It would be advisable to make the initial connections using the non-shared holes, and only put in the shared bolts once both knee support assemblies are correctly positioned.

Figure 85. Bolt holes for knee support / goal post assembly

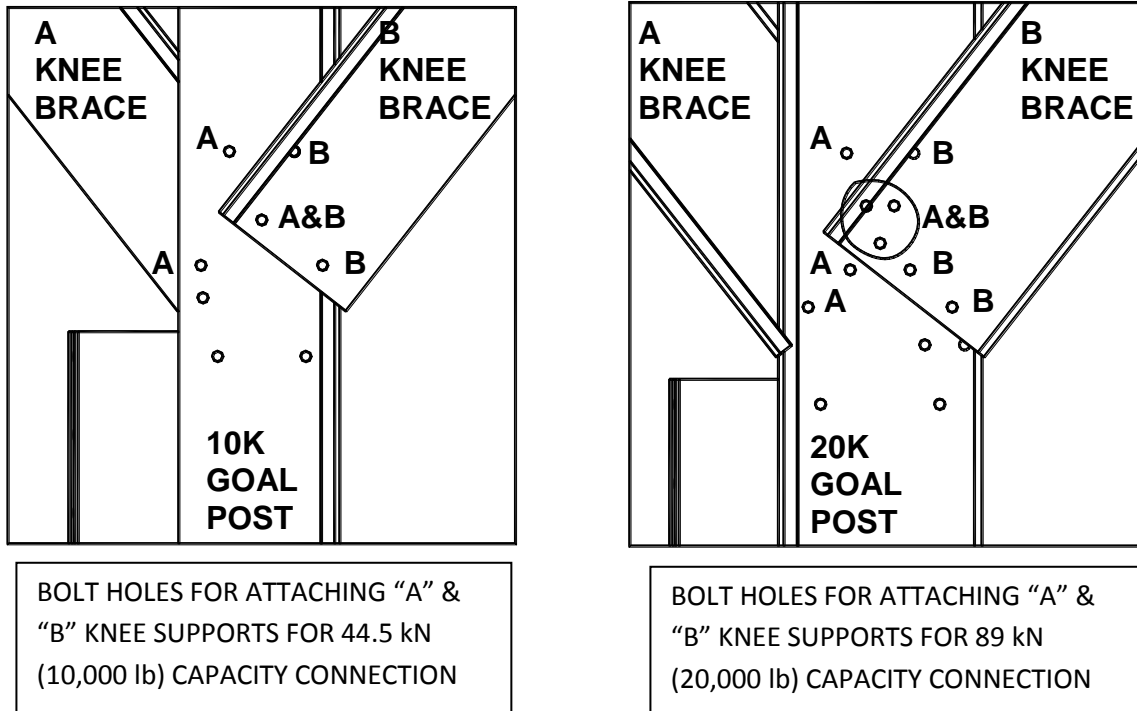

It would be preferable to assemble the knee supports to the goal posts on the ground and then hoist the completed assembly into place as a unit. When slinging the completed assembly insure the weight is supported such that excessive twisting and bending does not occur. Note that tubular braces span between the knee supports and goal posts at regular intervals. These bolt into holes spaced along the center web of the respective Z-columns (Figure 86 on page 89).

Figure 86. Assembly on the ground

TUBULAR BRACES SPAN BETWEEN HOLES IN FLAT SURFACE OF KNEE BRACE TO FLAT SURFACE OF GOAL POST. THE MATING SURFACES MAY BE OUTSIDE OR INSIDE DEPENDING ON THE SITUATION.

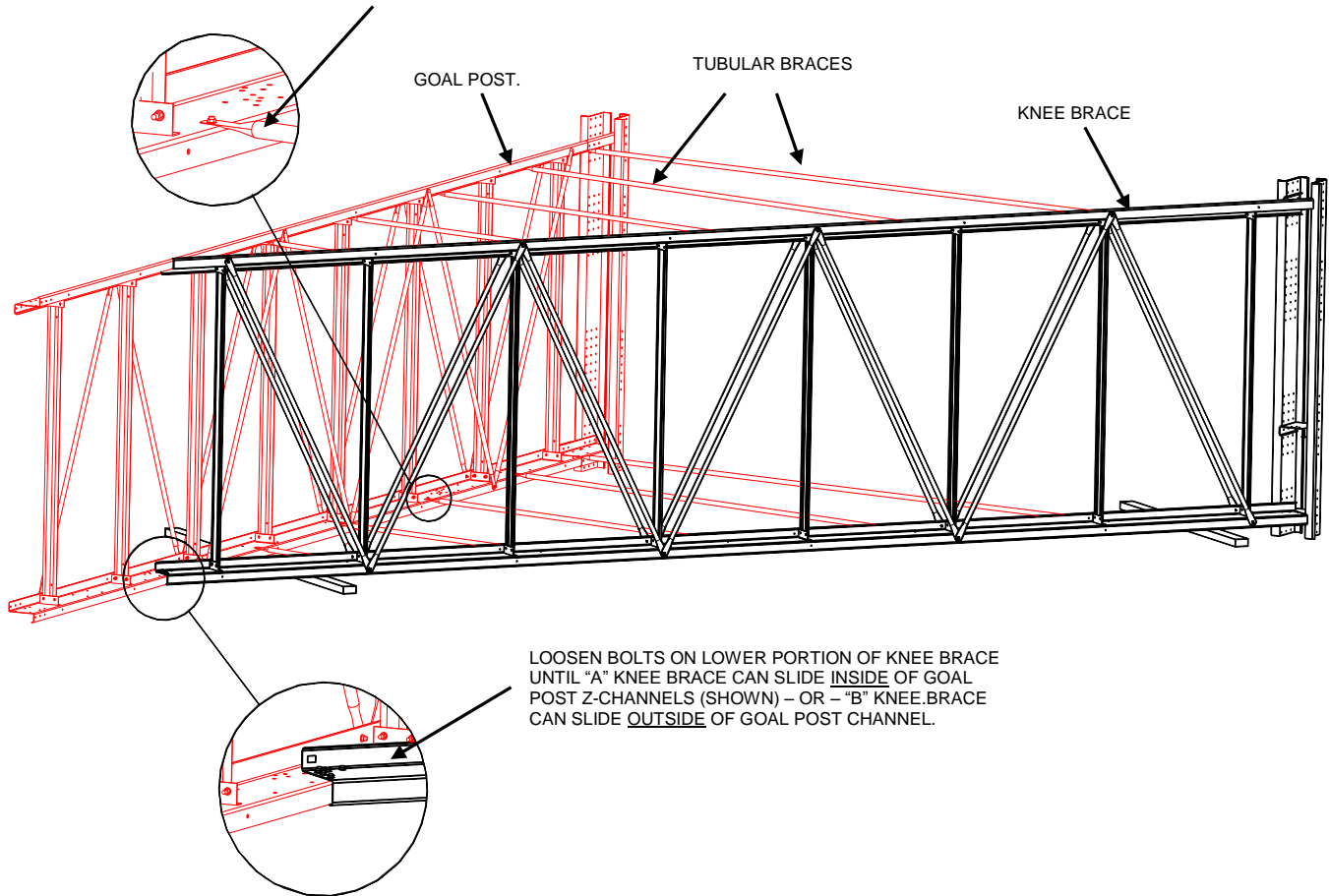

5.13.6 Connection to Grain Bin

The connection to the grain bin was described earlier in [Section 5.13.2 – Goal Post Assembly on page 80](#) and as illustrated below in [Figure 87 on page 90](#). When slinging the completed assembly into position, the vertical goal post Z-sections are positioned on the outside of the mating upright connectors. Make sure that the mating uprights on the grain bin have been upgraded as required.

Figure 87. Connection to the grain bin detail

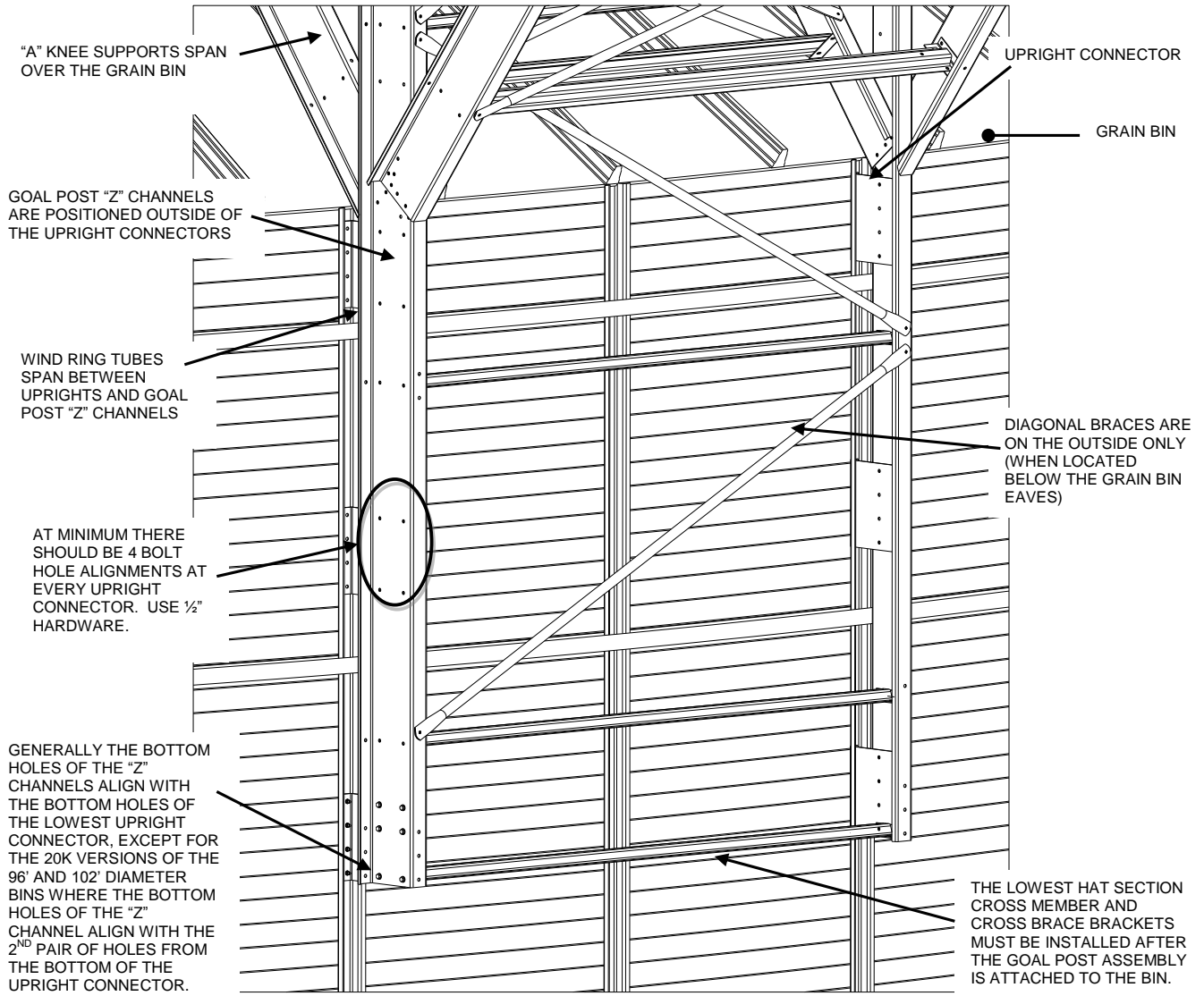

Each 44.5 kN (10,000 lb) connection utilizes 2 upright connectors per goal post. Each 89 kN (20,000 lb) connection utilizes 3 upright connectors per goal post ([Figure 88 on page 91](#)).

Figure 88. Connection to the grain bin detail

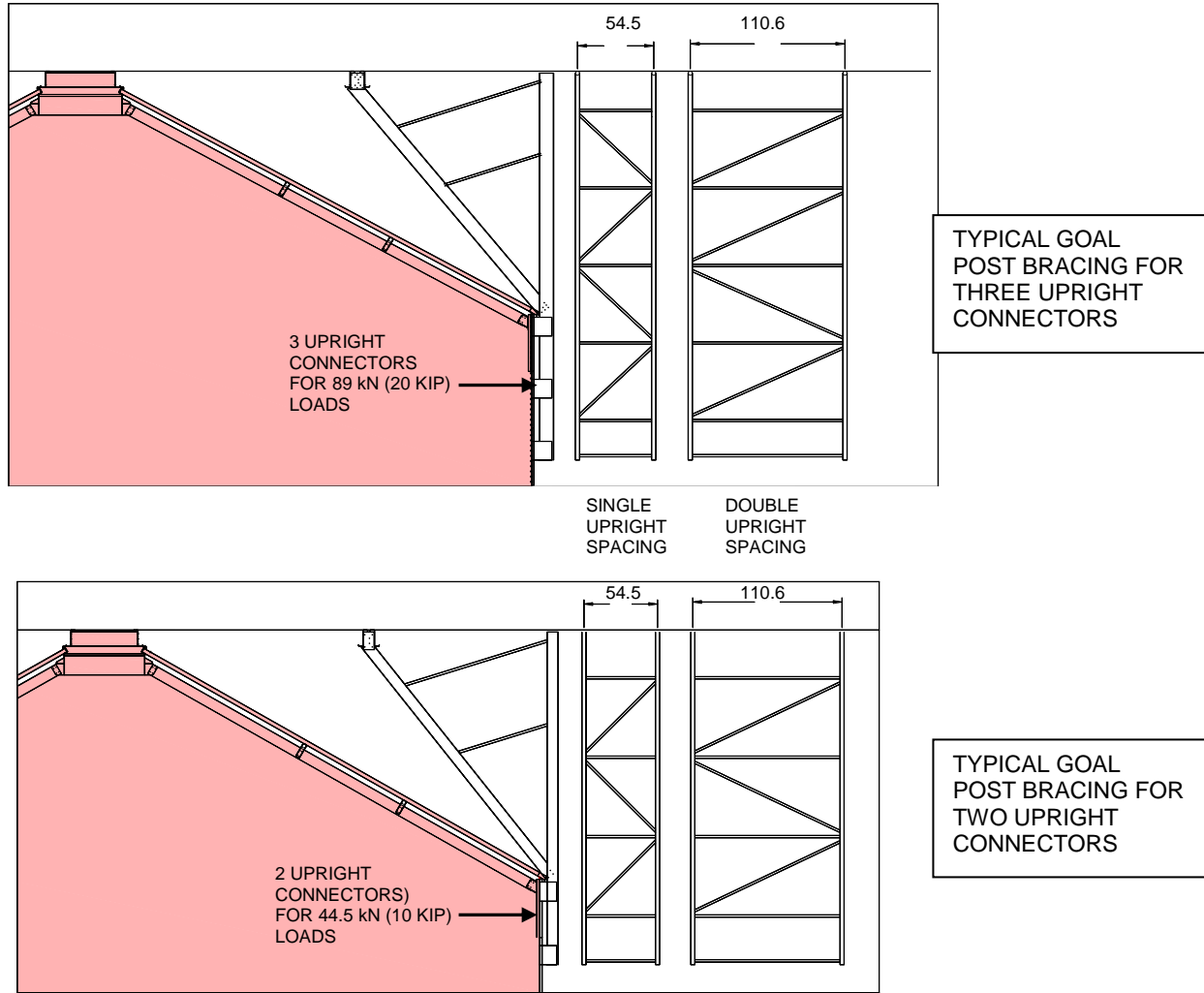

Holes in the goal post align with holes in the upright connectors, however not all upright connector holes will have mating goal post holes. At minimum 4 holes should align. Make the connection utilizing ½” hardware. In general, the bottom of the goal post aligns with the bottom of the lowest upright connector. There are two exceptions to this for the 89 kN (20,000 lb)versions of the 96’ and 102’ diameter bins. For these connections only, the bottom holes in the goal post align with the second pair of holes from the bottom of the upright connectors.

The bottom hat section cross brace and cross brace brackets must be installed after the connection is made to the bin as they are positioned on the inside of the upright connectors.

5.13.7 Alternative and Additional Bracing

The need for alternative or additional bracing is dependent on a number of variables, including site considerations, customer preferences, etc. The previous sections considered knee bracing only. The following explores some other alternatives. Review the specific site layouts for those that apply. If this bracing is being utilized it will be indicated on the site layouts.

In general additional bracing must be considered when certain limits are exceeded, as follows:

- 44.5 kN (10,000 lb) capacity goal posts – from 13.7 m (45’) to 33 m (108’) diameter bins

- 89 kN (20,000 lb) capacity goal posts – from 11 m (36') to 33 m (108') diameter bins

The next two sections provide examples of types of additional bracing.

Bracing Between Adjacent Goal Posts (without knee supports)

If there are two bins in close proximity of each other and both have goal posts but no knee supports (see [Figure 89 on page 93](#)), it may be necessary to brace between the them. Hat section braces span between the goal posts at regular 60" intervals. These may need to be shortened to fit the application depending on bin spacing. Tubular cross braces span between adjacent hat sections. If adjusting hat section lengths is necessary care should be taken to not interfere with tubular brace holes. Install on both sides.

Figure 89. Bracing between goal posts

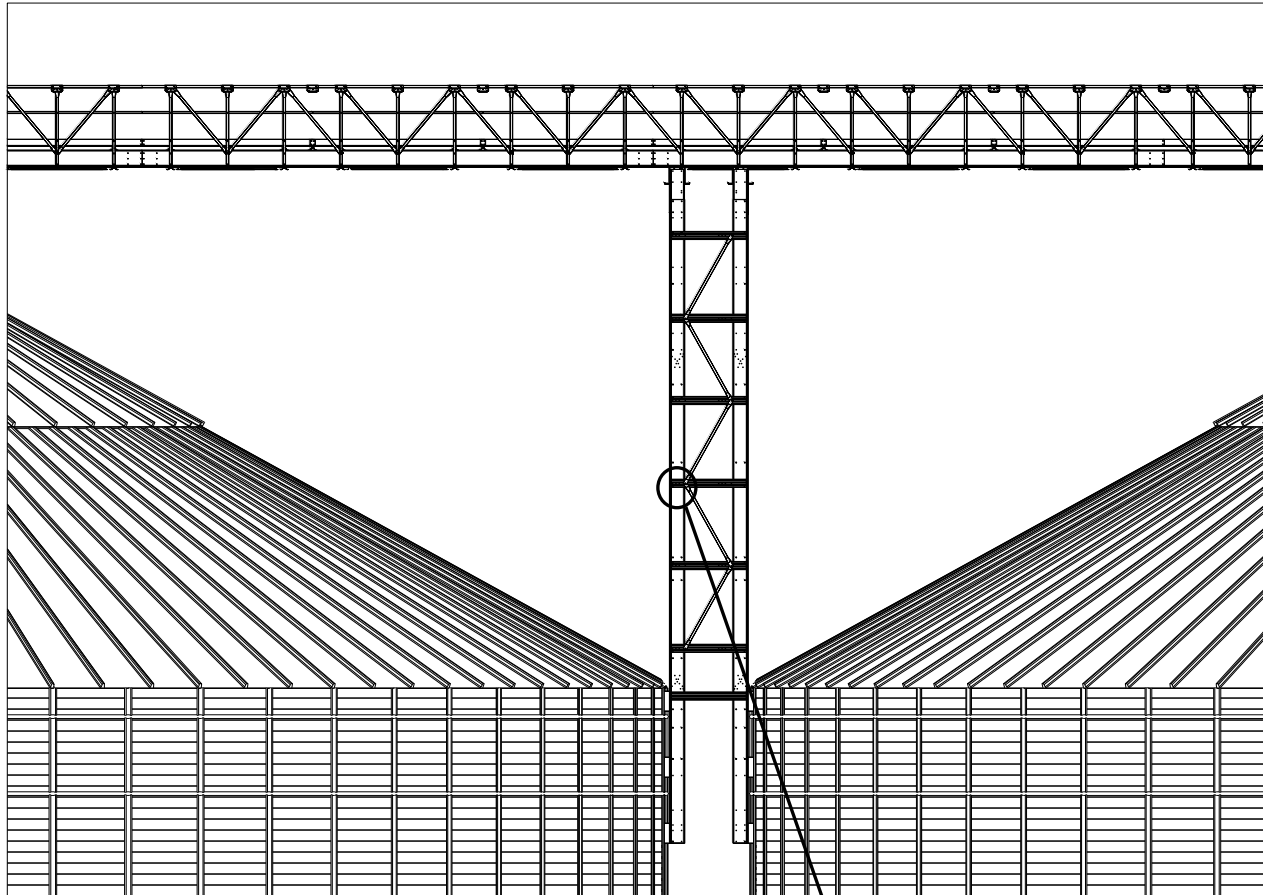

TUBULAR BRACES
ATTACHED TO OPPOSITE
SIDE OF HAT CHANNEL
WITH A SINGLE BOLT.

HAT CHANNEL ON OUTSIDE
OF GOAL POST. FASTENED
WITH A SINGLE BOLT ON
EACH END.

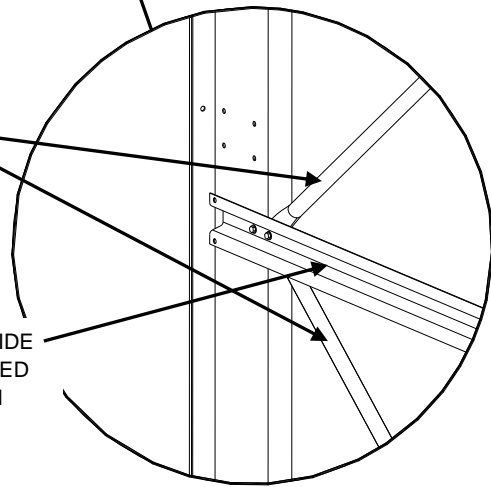

Bracing Between Adjacent Goal Posts (with knee supports)

If two bins are in close proximity of each other and both have goal posts with “A” knee supports only (see [Figure 90 on page 94](#)), it may be necessary to brace between them in the vicinity of the eave as illustrated. Here a hat section spans between the two goal post sections at the eave of the bins. The hat section may need to be shortened to fit depending on bin spacing. Install on both sides.

Figure 90. Bracing between goal posts and A knee supports

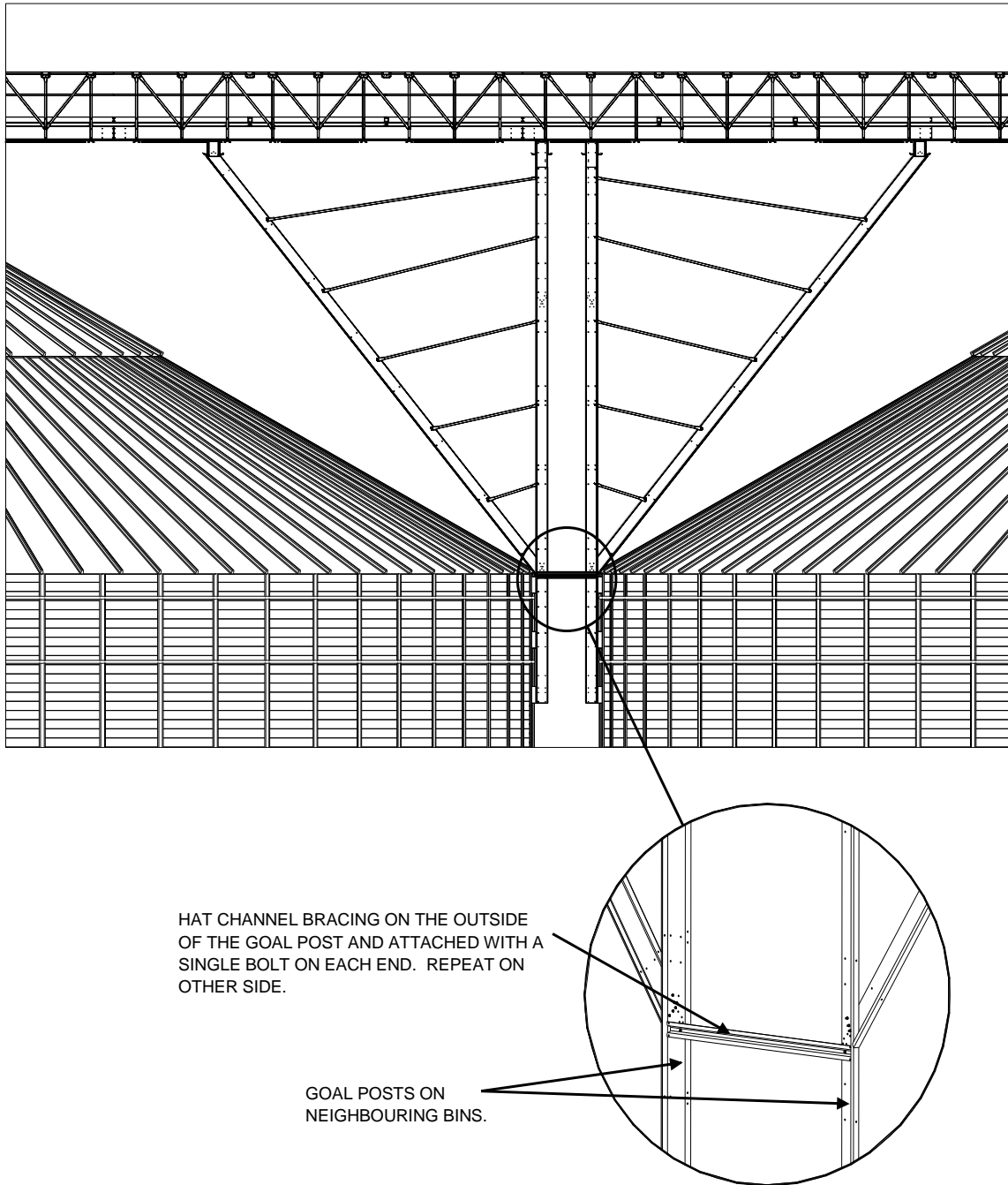

6. Appendix

6.1. Catwalk Parts Box Part Identification



213035 – End Plug Small



234559 – End Plug Large



234517 – Support Arm Clip



234518 – Support Arm Bracket



213029 – Corner Clip Large



213031 – Corner Clip Small



213065 – Ladder Stand-Off



213015 – Handrail Connection Bracket

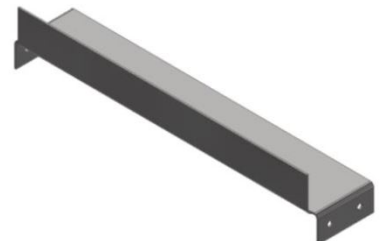

Various – Toe Board Sections

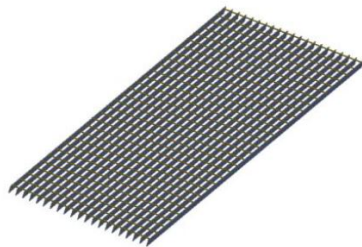

Various – Bar Grating Sections



Various – Support Arms



Various – Hat Section Cross Members



Various – Z-Section Beam



Various – Diagonal Braces

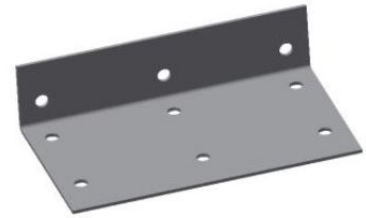

213053 – Cross Walk Bracket



213011 – Lateral Brace



213023 – Toe Board Splice



234505 – Ladder Pass Thru Rail



213064 – Toe Board Corner Splice

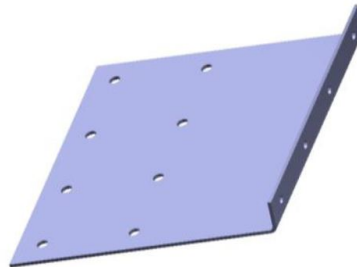

Various – Goal Post Brackets

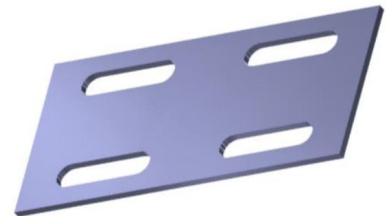

213066 – Toe Board Thermal Splice



213431 – Beam Support Bracket 10k

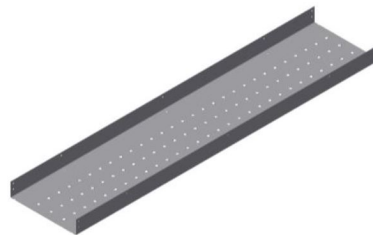

213013 – Punched Walkway



213631 – Beam Support Bracket 20k



213439 – Cross Brace Bracket 10K



213063 – Catwalk Bracket for Hinge and Latch



213409 – Cross Brace Bracket 20K

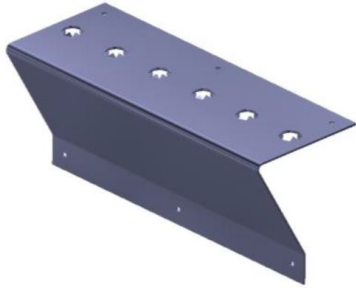

213062 – Access Step



213061 – Self Closing Gate Door

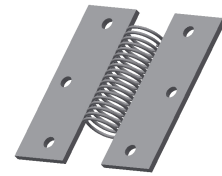

234695 – Self Closing Gate Hinge

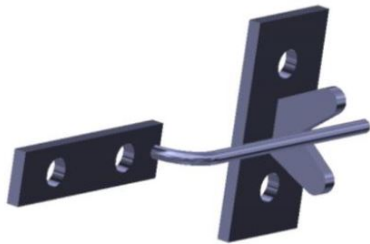

213376 – Self Closing Gate Latch

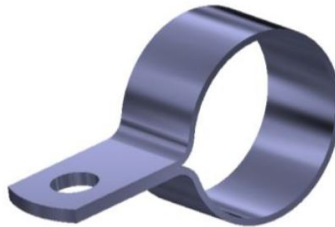

Various - Upright Connectors



234500 – Ladder Section



Various – Vertical Post End



213059 – Punched Walkway WA

6.2. Hardware Usage

Table 8. Bin Hardware

	1/4" x 3/4" Pan Socket Self Drilling Screw	1/4" x 3/4" Flanged Hex Bolt (Washer)	1/4" Hex Nut	3/8" x 1" Flanged Hex LL Adhesive Bolt	3/8" x 2" Flanged Hex LL Adhesive Bolt	3/8" x 2-1/2" Flanged Hex LL Adhesive Bolt	3/8" x 3-1/2" Flanged Hex LL Adhesive Bolt	3/8" Flanged Lock Nut	1/2" x 1-1/2" Flanged Hex LL Adhesive Bolt	1/2" Flanged Lock Nut
	235968 (50)	235901 (75)	235905 (125)	235961 (100)	235976 (100)	235964 (50)	235965 (50)	235955 (50)	235966 (50)	235967 (50)
H-CROSS BRACE to Z-SECTION BEAM				•				•		
H-DIAGONAL BRACE to Z-SECTION BEAM				•				•		
Z-SECTION BEAM to Z-SECTION BEAM SPLICE				•				•		
LATERAL BRACE to Z-SECTION BEAM				•				•		
LATERAL BRACE to H-CROSS BRACE				•				•		
TOE BOARD to TOE BOARD SPLICE				•				•		
CROSSWALK BRACKET to Z-SECTION BEAM				•				•		
ALL LADDER ACCESS CONNECTIONS to Z-SECTION or TOE BOARD				•				•		
STAMPED FLOOR to H-CROSS BRACE				•				•		
TOE BOARD to BAR GRATING FLOOR to H-CROSS BRACE					•			•		
VERTICAL POST to Z-SECTION BEAMS					•			•		
TOE BOARD to VERTICAL POST					•			•		
PASS THRU RAILS to LADDER RAILS at CATWALK ACCESS POINTS					•			•		
VERTICAL POST to MID RAIL - STD						•		•		
VERTICAL POST to MID RAIL - HD							•	•		
DIAGONAL BRACE to VERTICAL POST to Z-SECTION BEAMS						•		•		
GOAL POST BRACKETS to GRAIN BIN UPRIGHTS (DOUBLE NUT)				•				•		
PEAK SUPPORT ASSEMBLY									•	•
GOAL POST ASSEMBLY									•	•
KNEE BRACE ASSEMBLY									•	•
HANDRAIL CONNECTION BRACKET to HANDRAILS	•									
HANDRAIL CONNECTION BRACKET to VERTICAL POST or DIAGONAL BRACES				•				•		
MID RAIL TUBES to SPLICE TUBE	•									
CORNER BRACKETS to HANDRAIL or MID-RAIL TUBES	•									
CONNECTOR CLIPS to TOP RAIL to VERTICAL POST	•									
DOOR ANGLE BRACKET to HANDRAIL	•■	•■	•■							

Table 8 Bin Hardware (continued)

	1/4" x 3/4" Pan Socket Self Drilling Screw	1/4" x 3/4" Flanged Hex Bolt (Washer)	1/4" Hex Nut	3/8" x 1" Flanged Hex LL Adhesive Bolt	3/8" x 2" Flanged Hex LL Adhesive Bolt	3/8" x 2-1/2" Flanged Hex LL Adhesive Bolt	3/8" x 3-1/2" Flanged Hex LL Adhesive Bolt	3/8" Flanged Lock Nut	1/2" x 1-1/2" Flanged Hex LL Adhesive Bolt	1/2" Flanged Lock Nut
	235968 (50)	235901 (75)	235905 (125)	235961 (100)	235976 (100)	235964 (50)	235965 (50)	235955 (50)	235966 (50)	235967 (50)
DOOR ANGLE BRACKET to LADDER SUPPORT ARM BRACKET to MIDRAIL	• ■	• ■	• ■							
HINGE to DOOR ANGLE BRACKET and DOOR PAN	• ■	• ■	• ■							
LATCH to DOOR ANGLE BRACKET and DOOR PAN	• ■	• ■	• ■							
#2 ROBERTSON BIT - 213033	•									

Note

■ — Can use either 1/4" self drilling screws, or 1/4" bolts and nuts at these locations.

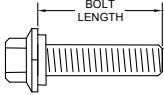
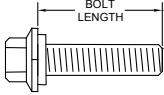
7. Limited Warranty: Westeel Grain Bin Products

Westeel – Ag Growth International ("Westeel") warrants products that it has manufactured and/or that are branded with its name (the "goods") subject to the following terms and limitations, (the "warranty"):

Duration of Warranty

This warranty will run from the date of purchase from the dealer or distributor, authorized by Westeel. The duration of the warranty is limited as follows:

Galvanized Bins	5 years
EasyFlow2	24 months
Westeel Fans	36 months
Floors	12 months
Catwalk	12 months
Bulk Feed Tanks	24 months
SeedStor-K Cones	
Paint	12 months
Structural	30 months
Elite Cones	
Paint	30 months
Structural	10 years
WESTEEL cones	
Paint	No Warranty
Structural	12 months
Smooth Wall Bins	
Paint	60 months
Structural	10 years
Commercial Smooth Wall Bins	
Paint	12 months
Structural	10 years

Limitation of Remedies Replacement

Within the warranty period, Westeel will replace the goods and/or original manufactured components thereof which are found, to Westeel's satisfaction, to be defective. Westeel is not responsible for direct, indirect, special, consequential, or any other damages of any kind, including personal injury to any individual, howsoever caused, including caused by transportation of the goods for repair or replacement.

Procedure for Obtaining Service

In the event of a warranty claim, the purchaser must complete any and all information required by Westeel in order to properly assess or investigate the claim. Westeel will not be responsible for the removal of any of the goods found to be defective, or transportation charges to and from Westeel's authorized dealer or distributor, or for installation of any replacement goods and/or parts furnished under the warranty.

Limitations as to Scope of Warranty

The warranty does not extend to defects or damage caused, in whole or in part, by:

1. use of a kind and/or to a degree not reasonably expected to be made of the goods;
2. improper storage of the goods both prior to and after purchase;
3. damage caused by, or in the course of, installation or assembly;
4. any use of the goods which is not an intended use as specified in Westeel's published product literature, or otherwise specified by Westeel in writing;
5. any equipment attached to or used in conjunction with the goods;
6. any field modifications or substitutions to original bin components;
7. inadequate ventilation or any other circumstance not in keeping with proper maintenance and/or use of the goods;
8. Acts of God, accident, neglect or abuse of the goods by the purchaser and/or any other individual or entity; or
9. Any use or installation inconsistent with Westeel's Standard Disclaimers.

Limitations as to Manufacturer

The warranty does not cover products sold by Westeel that are not manufactured by Westeel. In those circumstances, the purchaser is referred to the manufacturer of those products.

Limitation of Implied Warranties and Other Remedies

To the extent allowed by law, neither Westeel nor its dealers, nor any company affiliated with Westeel makes any warranties, representations, or promises as to the quality, performance, or freedom from defect of any Product covered by this Warranty.

WESTEEL HEREBY DISCLAIMS, TO THE EXTENT APPLICABLE, ANY AND ALL IMPLIED WARRANTIES OF MERCHANTABILITY AND FITNESS FOR A PARTICULAR PURPOSE. A PURCHASER'S ONLY REMEDIES IN CONNECTION WITH THIS WARRANTY ARE THOSE SET FORTH IN THIS WARRANTY. IN NO EVENT WILL WESTEEL, ITS DEALERS, OR ANY COMPANY AFFILIATED WITH WESTEEL BE LIABLE FOR INCIDENTAL, CONSEQUENTIAL OR PUNITIVE DAMAGES.

Some jurisdictions do not allow waivers of certain warranties, so the above waivers may not apply to you. In that event, any implied warranties are limited in duration to ninety (90) days from delivery of the products. You may also have other rights which vary from jurisdiction to jurisdiction.

Exclusive Warranty

This warranty is the only warranty provided by Westeel and all other warranties and/or commitments, whether express or implied and no matter by whom made, statutory or otherwise, are subsumed and replaced by it and are of no legal effect. If any provision of the warranty is held by a court of

competent jurisdiction to be void or unenforceable, in whole or in part, such provision shall be deemed severable and will not affect or impair the legal validity of any other provision of the warranty.



450 Desautels Street
P.O. Box 792
Winnipeg, Manitoba, R3C 2N5 Canada
Phone: 1-888-937-8335

Website: www.aggrowth.com
Email: customerservice.winnipeg@westeel.com
©Ag Growth International Inc. 2020
Printed in Canada

If you have any comments or questions on this manual, or find an error, email us at comments@aggrowth.com.
Please include the part number listed on the cover page in your message.