



EasyFlow2 High Output (100 Series)

Farm High Output U-Trough Bin Unload System Assembly & Installation Manual

This manual applies to:

EasyFlow2: Bin Diameters: 24', 27', 30', 33', 36', 39', 42', 45', 48', 51', 54', 60'

High Output
U-Trough
Unload



Read this manual before using product. Failure to follow instructions and safety precautions can result in serious injury, death, or property damage. Keep manual for future reference.

Part Number: BU-0101740 R6

Revised: February 2021

Original Instructions

New in this Manual

The following changes have been made in this revision of the manual:

Description	Section
Added Positioning the Underfloor Auger section.	Section 6.3 – Positioning the Underfloor Auger on page 28
New gearbox assembly.	Section 6.4 – Install Tandem Gearboxes in the Center Sump on page 37
Moved Install Tandem Gearboxes in the Center Sump section.	Section 6.4 – Install Tandem Gearboxes in the Center Sump on page 37
Modified the center sump design.	Section 6.4 – Install Tandem Gearboxes in the Center Sump on page 37
Modified the Install the Underfloor Auger section.	Section 6.5 – Install the Underfloor Auger on page 40
New underfloor lighting.	Section 6.5 – Install the Underfloor Auger on page 40
Modified the intermediate grate design.	Section 6.10 – Floor Plank Completion and Sump Grates on page 46
Modified the incline powerhead flight.	Section 6.12 – Assemble the Incline Powerhead (Optional) on page 49
Added internal hanger bearing for powerhead.	Section 6.13 – Assemble the Electric Powerhead (if Equipped) on page 51
	Section 6.15 – Assemble the Hydraulic Powerhead (if Equipped) on page 56
Modified the backboard design.	Section 6.20 – Adjust the Bin Sweep Extension on page 64

CONTENTS

1. Introduction	5
2. Safety.....	6
2.1 Safety Alert Symbol and Signal Words.....	6
2.2 Follow Safety Instructions.....	6
2.3 Rotating Flighting Safety	7
2.4 Rotating Parts Safety.....	7
2.5 Drives and Lockout Safety.....	7
2.5.1 Electric Motor Safety.....	8
2.5.2 Hydraulic Power Safety	9
2.6 Personal Protective Equipment.....	9
2.7 Safety Equipment	10
2.8 Safety Decals	10
2.8.1 Decal Installation/Replacement.....	10
2.8.2 Safety Decal Locations and Details	11
3. Features.....	17
4. Preparation	18
4.1 Diameter Tolerance.....	18
4.2 Intended Floor Types.....	18
4.3 Bin Height	21
4.4 Bin Wall Cutout	22
4.5 Retrofit Information	23
4.6 Installation Planning.....	23
5. Pre-Assembly	24
5.1 Check Shipment.....	24
5.2 Before You Begin	24
5.3 Required Materials.....	24
5.4 Required Lifting Equipment	25
5.5 Required Tools.....	26
6. Assembly	27
6.1 Assembly Safety	27
6.2 Bin Floor Preparation	27
6.3 Positioning the Underfloor Auger.....	28
6.3.1 Removing the Bin Sheet.....	28
6.3.2 Cutting a Bin Sheet in Place	30
6.4 Install Tandem Gearboxes in the Center Sump	37
6.5 Install the Underfloor Auger	40
6.6 Install the Bin Adapter.....	41
6.7 Reassemble the E-Sump Controls	45
6.8 Reassemble Sump Control Knobs	45
6.9 Reassemble Lower Gearbox Controls	45
6.10 Floor Plank Completion and Sump Grates.....	46
6.11 Assemble the U-Trough Extension (Optional)	48
6.12 Assemble the Incline Powerhead (Optional)	49
6.13 Assemble the Electric Powerhead (if Equipped).....	51
6.14 Electric Motor Installation / Alignment (if Equipped)	54

6.15 Assemble the Hydraulic Powerhead (if Equipped)	56
6.16 Install the Sweep End Wheel, Flighting, and Backboard	58
6.17 Set Backboard Clearance.....	59
6.18 Install the Sweep Stop.....	61
6.19 Testing	62
6.20 Adjust the Bin Sweep Extension.....	64
6.21 Attach the Westeel Brand Logo Decal	65
7. Specifications	67
7.1 Mechanical	67
7.2 Bin Unload System Sizes.....	68
7.3 Power Requirements.....	69
8. Bin Unload Limited Warranty	70

1. Introduction

Before assembling, please read this manual. Familiarize yourself with the process and the necessary precautions for efficient and safe assembly of this Westeel Farm High Output U-Trough Bin Unload System.

Everyone present at the assembly site is required to be familiar with all safety precautions.

Keep this manual available for frequent reference and review it with new personnel. Call your local distributor or dealer if you need assistance or additional information.

2. Safety

2.1. Safety Alert Symbol and Signal Words



This safety alert symbol indicates important safety messages in this manual. When you see this symbol, be alert to the possibility of injury or death, carefully read the message that follows, and inform others.

Signal Words: Note the use of the signal words **DANGER**, **WARNING**, **CAUTION**, and **NOTICE** with the safety messages. The appropriate signal word for each message has been selected using the definitions below as a guideline.



DANGER Indicates an imminently hazardous situation that, if not avoided, will result in serious injury or death.



WARNING Indicates a hazardous situation that, if not avoided, could result in serious injury or death.



CAUTION Indicates a hazardous situation that, if not avoided, may result in minor or moderate injury.



NOTICE Indicates a potentially hazardous situation that, if not avoided, may result in property damage.

2.2. Follow Safety Instructions

Read and understand all safety instructions, safety decals, and manuals and follow them when operating or maintaining the equipment.

- Owners must give instructions and review the information initially and annually with all personnel before allowing them in the work area. Untrained users/operators expose themselves and bystanders to possible serious injury or death.
- Use for intended purposes only.
- Do not modify the bin unload in any way without written permission from the manufacturer and is not covered by the warranty.
- Follow a health and safety program for your worksite. Contact your local occupational health and safety organization for information.
- Follow applicable local codes and regulations.



2.3. Rotating Flighting Safety

DANGER

- KEEP AWAY from rotating flighting.
- DO NOT remove or modify flighting guards, doors, or covers. Keep in good working order. Have replaced if damaged.
- DO NOT operate the bin unload without all guards, doors, and covers in place.
- NEVER touch the flighting. Use a stick or other tool to remove an obstruction or clean out.
- Shut off and lock out power to adjust, service, or clean.



2.4. Rotating Parts Safety

WARNING

- Keep body, hair, and clothing away from rotating pulleys, belts, chains, and sprockets.
- Do not operate with any guard removed or modified. Keep guards in good working order.
- Shut off and lock out power source before inspecting or servicing machine.



2.5. Drives and Lockout Safety

Inspect the power source(s) before using and know how to shut down in an emergency. Whenever you service or adjust your equipment, make sure you shut down the power source and follow lockout and tagout procedures to prevent inadvertent start-up and hazardous energy release. Know the procedure(s) that applies to your equipment from the following power source(s). Ensure that only 1 key exists for each assigned lock, and that you are the only one that holds that key. Ensure that all personnel are clear before turning on power to equipment.



2.5.1 Electric Motor Safety

WARNING Power Source

- Electric motors and controls shall be installed and serviced by a qualified electrician and must meet all local codes and standards.
- Use a magnetic starter to protect the electric motor.
- You must have a manual reset button.
- Reset and motor starting controls must be located so that the operator has full view of the entire operation.
- Locate main power disconnect switch within reach from ground level to permit ready access in case of an emergency.
- Motor must be properly grounded.
- Ensure electrical wiring and cords remain in good condition; replace if necessary.

Lockout

- The main power disconnect switch should be in the locked position during shutdown or whenever maintenance is performed.
- If reset is required, disconnect all power before resetting motor.

SERVICE DISCONNECT

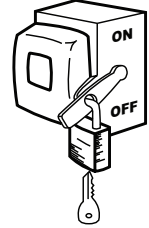

2.5.2 Hydraulic Power Safety

WARNING Power Source

- Refer to the rules and regulations applicable to the power source operating your hydraulic drive.
- Do not connect or disconnect hydraulic lines while system is under pressure.
- Keep all hydraulic lines away from moving parts and pinch points.
- Escaping hydraulic fluid under pressure will cause serious injury if it penetrates the skin surface (serious infection or toxic reaction can develop). See a doctor immediately if injured.
- Use metal or wood as a backstop when searching for hydraulic leaks and wear proper hand and eye protection.
- Check all hydraulic components are tight and in good condition. Replace any worn, cut, abraded, flattened, or crimped hoses.
- Clean the connections before connecting to equipment.
- Do not attempt any makeshift repairs to the hydraulic fittings or hoses with tape, clamps, or adhesive. The hydraulic system operates under extremely high pressure; such repairs will fail suddenly and create a hazardous and unsafe condition.

Lockout

- Always place all hydraulic controls in neutral and relieve system pressure before disconnecting or working on hydraulic system.



2.6. Personal Protective Equipment

The following Personal Protective Equipment (PPE) should be worn when assembling the equipment.

Safety Glasses

- Wear safety glasses at all times to protect eyes from debris.

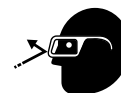

Work Gloves

- Wear work gloves to protect your hands from sharp and rough edges.



Steel-Toe Boots

- Wear steel-toe boots to protect feet from falling debris.



Coveralls

- Wear coveralls to protect skin.



Hard Hat

- Wear a hard hat to help protect your head.



2.7. Safety Equipment

The following safety equipment should be kept on site.

Fire Extinguisher

- Provide a fire extinguisher for use in case of an accident. Store in a highly visible and accessible place.



First-Aid Kit

- Have a properly-stocked first-aid kit available for use should the need arise, and know how to use it.



2.8. Safety Decals

- Keep safety decals clean and legible at all times.
- Replace safety decals that are missing or have become illegible. See decal location figures that follow.
- Replaced parts must display the same decal(s) as the original part.
- Replacement safety decals are available **free of charge** from your distributor, dealer, or factory as applicable.

2.8.1 Decal Installation/Replacement

1. Decal area must be clean and dry, with a temperature above 50°F (10°C).
2. Decide on the exact position before you remove the backing paper.
3. Align the decal over the specified area and carefully press the small portion with the exposed sticky backing in place.
4. Slowly peel back the remaining paper and carefully smooth the remaining portion of the decal in place.
5. Small air pockets can be pierced with a pin and smoothed out using the decal backing paper.

2.8.2 Safety Decal Locations and Details

Replicas of the safety decals that are attached to the bin unload and their messages are shown in the figure(s) that follow. Safe operation and use of the bin unload requires that you familiarize yourself with the various safety decals and the areas or particular functions that the decals apply to, as well as the safety precautions that must be taken to avoid serious injury, death, or damage.

Figure 1. Safety Decal Locations

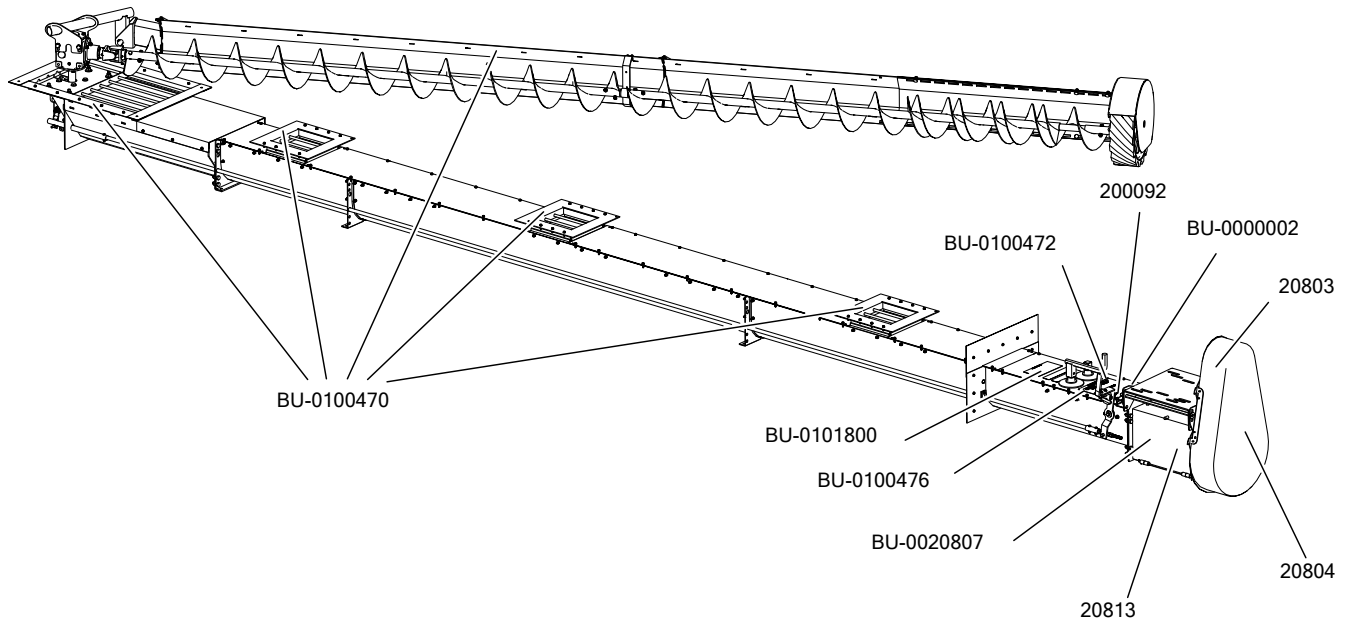

Note

Decal locations same on incline discharge.

Figure 2. Hydraulic Powerhead Decal Locations

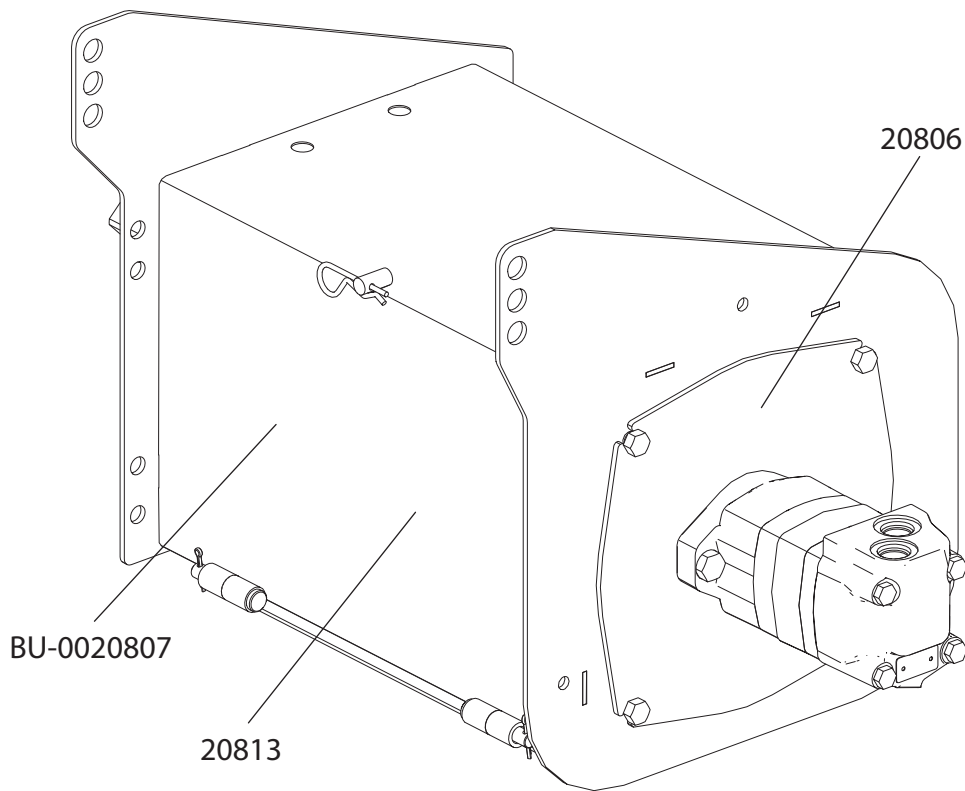

Table 1. Safety Decals



Part Number	Description
BU-0100470	 <div style="border: 1px solid black; padding: 5px; margin-top: 5px;"> <p style="text-align: center;">⚠ DANGER</p> <p>ROTATING FLIGHTING HAZARD To prevent serious injury or death:</p> <ul style="list-style-type: none"> • KEEP OUT of bin while sweep is operating. • KEEP AWAY from rotating auger flighting. • NEVER touch the auger flighting. Use a stick or other tool to remove an obstruction or clean out. • Shut off and lock out power before entering bin to adjust, service, or clean. </div>
20813	<div style="border: 1px solid black; padding: 10px;"> <p style="text-align: center;">⚠ DANGER</p>  <p style="text-align: center;">ROTATING FLIGHTING HAZARD</p> <p>To prevent death or serious injury:</p> <ul style="list-style-type: none"> • KEEP AWAY from rotating auger flighting. • DO NOT remove or modify auger flighting guards, doors, or covers. Keep in good working order. Have replaced if damaged. • DO NOT operate the auger without all guards, doors, and covers in place. • NEVER touch the auger flighting. Use a stick or other tool to remove an obstruction or clean out. • Shut off and lock out power to adjust, service, or clean. </div>
20803	<div style="border: 1px solid black; padding: 10px;"> <p style="text-align: center;">⚠ WARNING</p>  <p style="text-align: center;">MISSING GUARD HAZARD</p> <p>To prevent serious injury or death, shut off power and reattach guard before operating machine.</p> </div>

Table 1 Safety Decals (continued)



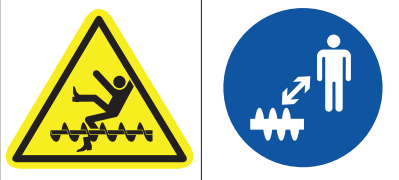

Part Number	Description
20804	<div style="border: 1px solid black; padding: 5px;"> <div style="background-color: #f4a460; text-align: center; padding: 2px;">⚠ WARNING</div> <div style="display: flex; justify-content: space-around; align-items: center;">   </div> <div style="text-align: center; padding: 5px;">ENTANGLEMENT HAZARD</div> <p>To prevent serious injury or death:</p> <ul style="list-style-type: none"> • Keep body, hair, and clothing away from rotating pulleys, belts, chains, and sprockets. • Do not operate with any guard removed or modified. Keep guards in good working order. • Shut off and lock out power source before inspecting or servicing machine. </div>
20806	<div style="border: 1px solid black; padding: 5px;"> <div style="display: flex; justify-content: space-between; align-items: center;">  <div style="background-color: #f4a460; text-align: center; padding: 2px;">⚠ WARNING</div> </div> <div style="text-align: center; padding: 5px;">HIGH PRESSURE FLUID HAZARD</div> <p>Hydraulic fluid can cause serious injury if it penetrates the skin. If it does, see a doctor immediately.</p> <ul style="list-style-type: none"> • Relieve system pressure before repairing, adjusting or disconnecting. • Wear proper hand and eye protection when searching for leaks. Use wood or cardboard instead of hands. <div style="display: flex; justify-content: space-between; align-items: center; margin-top: 10px;">   </div> </div>
BU-000002	<div style="border: 1px solid black; padding: 5px;"> <div style="background-color: #f4a460; text-align: center; padding: 2px;">⚠ WARNING</div> <div style="display: flex; justify-content: space-around; align-items: center;">   </div> <div style="text-align: center; padding: 5px;">BIN COLLAPSE HAZARD</div> <p>Center hopper must be opened first to empty bin. Failure to follow could result in structural damage, serious injury, or death.</p> </div>

Table 1 Safety Decals (continued)



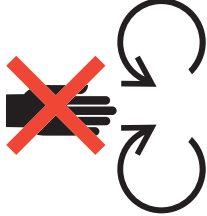

Part Number	Description
BU-0020807	<div style="border: 1px solid black; padding: 10px;"> <div style="background-color: #f4a460; text-align: center; padding: 5px; border: 1px solid black;">  WARNING </div> <div style="display: flex; justify-content: space-around; margin-top: 10px;"> <div style="text-align: center;">  </div> <div style="text-align: center;">  </div> </div> <p style="margin-top: 10px;">To prevent serious injury or death:</p> <ul style="list-style-type: none"> Read and understand the manual before assembling, operating, or maintaining the equipment. Only trained personnel may assemble, operate, or maintain the equipment. Children and untrained personnel must be kept outside of the work area. Do not modify the equipment. Keep in good working order. Lock out power before performing maintenance. If the manual, guards, or decals are missing or damaged, contact factory or representative for free replacements. </div>
BU-0100476	<div style="border: 1px solid black; padding: 10px;"> <div style="background-color: #0056b3; color: white; text-align: center; padding: 5px; border: 1px solid black;"> NOTICE </div> <p style="margin-top: 10px;">To prevent damage to the unload system, DO NOT engage bin sweep while underfloor auger is operating.</p> <p>To operate bin sweep:</p> <ol style="list-style-type: none"> 1. Shut down and lock out all power to the unload system. 2. Engage the bin sweep. 3. Engage power to operate the system. </div>

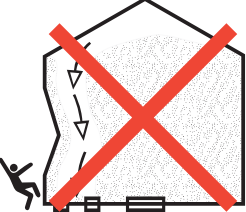
Table 1 Safety Decals (continued)

Part Number	Description
BU-0101800	<div style="text-align: center; border: 1px solid black; padding: 5px;"> <p>OPERATING PROCEDURE</p>  <p>Center Hopper Intermediate Hoppers BinSweep</p> </div>
BU-0100472	<div style="text-align: center; border: 1px solid black; padding: 5px;"> <p>OPERATING PROCEDURE</p>  <p>Intermediate Hoppers Open Center Hopper Open</p> <p>Bin Sweep Pull handle to engage and operate.</p> </div>
200092	<div style="text-align: center; border: 1px solid black; padding: 5px;">  <p>DISENGAGE</p> <p>ENGAGE</p> </div>

3. Features

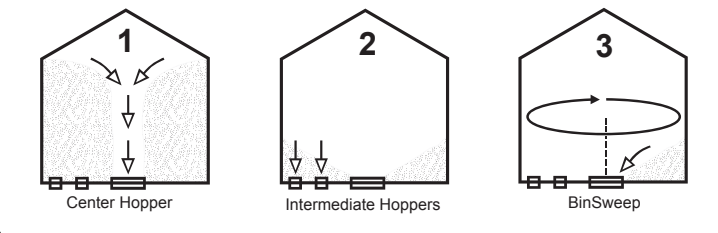
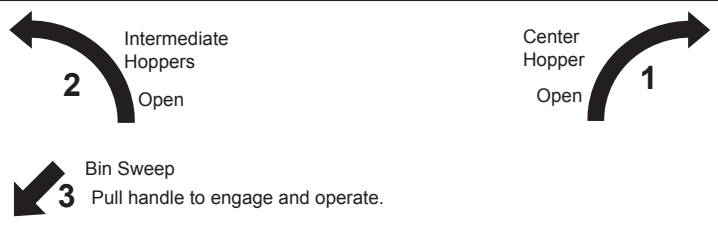
Read this section to familiarize yourself with the basic component names and functions of the bin unload.

Figure 3. Bin Unload System Features

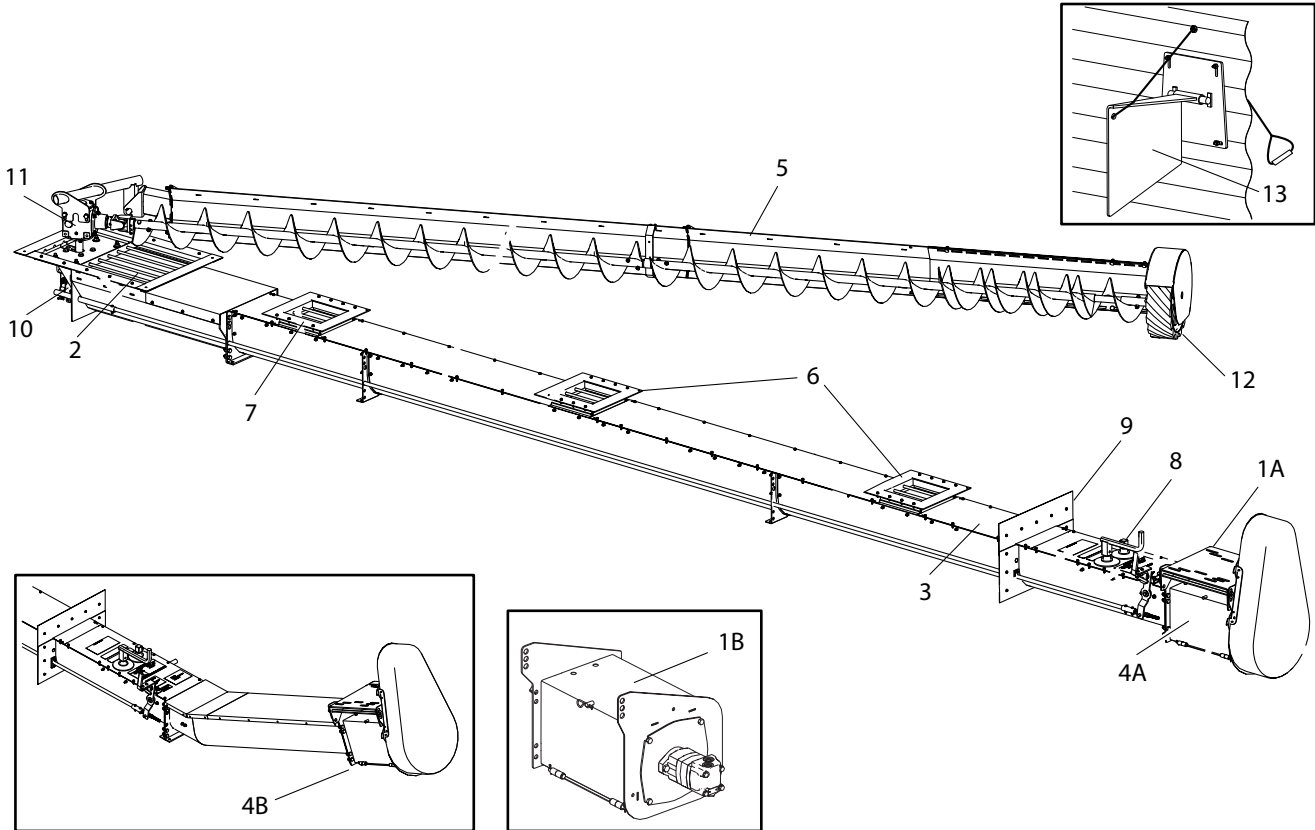

Table 2. Bin Unload System Features

Item	Description	Item	Description
1A	Electric Powerhead	7	Emergency Sump (E-Sump)
1B	Hydraulic Powerhead	8	Controls
2	Center Sump (Hopper)	9	Bin Adapter
3	Underfloor Auger	10	Lower Gearbox
4A	Horizontal Discharge	11	Upper Gearbox
4B	Incline Discharge	12	Sweep Drive Wheel
5	Bin Sweep	13	Sweep Stop
6	Intermediate Sump (Hopper)		

Optional u-trough extensions are available in lengths of 3', 4.5', 6' and 9'.

4. Preparation

4.1. Diameter Tolerance

In order to use the Westeel Farm High Output U-Trough Bin Unload System bin unload, the bin diameter must be within the tolerance in the following table.

Table 3. Bin Diameter Tolerances for Bin Unload Models

Bin Unload Model	Bin Diameter Tolerance
24'	23'6" - 25'6" (7.16 - 7.77 m)
27'	26'6" - 27'6" (8.08 - 8.38 m)
30'	29'6" - 30'6" (8.99 - 9.30 m)
33'	32'6" - 33'6" (9.91 - 10.21 m)
36'	35'6" - 36'6" (10.82 - 11.13 m)
39'	38'6" - 39'6" (11.73 - 12.04 m)
42'	41'6" - 42'6" (12.65 - 12.95 m)
45'	44'6" - 45'6" (13.56 - 13.87 m)
48'	47'6" - 48'6" (14.48 - 14.78 m)
51'	50'6" - 51'6" (15.39 - 15.70 m)
54'	53'6" - 54'6" (16.31 - 16.61 m)
60'	59'6" - 60'6" (18.14 - 18.44 m)

4.2. Intended Floor Types

The unload system may be installed as part of a:

- full floor aeration system
- concrete form with an aeration pit
- trench in a full concrete foundation

The instructions in this manual are written for full floor aeration systems, however any type may be safely used noting the additional requirements below.

Concrete Form with an Aeration Pit

Install the tandem gearboxes in the center sump before positioning the underfloor auger in the trench to prevent clearance problems.

Connect the bin adapter pieces to the concrete form wall using eleven 1/4" x 1-1/4" self-tapping **concrete** screws (purchased separately).

Trench in a Full Concrete Foundation

The concrete floor must meet the dimensions in the figure below.

Install the tandem gearboxes in the center sump before positioning the underfloor auger in the trench to prevent clearance problems.

Do not install the anchor legs (they are unnecessary and would cause clearance problems).

The bin adapter top piece may not fit against the underfloor auger and corrugated bin wall in the same way as the lower pieces. In this case, use another method to seal the top of the underfloor auger to the bin.

Connect the bin adapter pieces to the concrete foundation using six 1/4" x 1-1/4" self-tapping **concrete** screws purchased separately.

Cover the underfloor auger with 23" (584 mm) length steel planks, wood planks, or aeration planks (not supplied). The planks must be strong enough to support the weight of grain.

Use standard bin flashing (can be purchased through Westeel) to cover the small gaps where the planks meet the concrete foundation.

Table 4. Rating for 23" Floor Planks

Bin Unload Model (Bin Diameter)	Maximum Number of Bin Tiers
24'	13
27'	
30'	
33'	12
36'	11
39'	10
42'	
45'	9
48'	
51'	
54'	8
60'	

Figure 4. Trench Dimensions for Concrete Foundation Floor

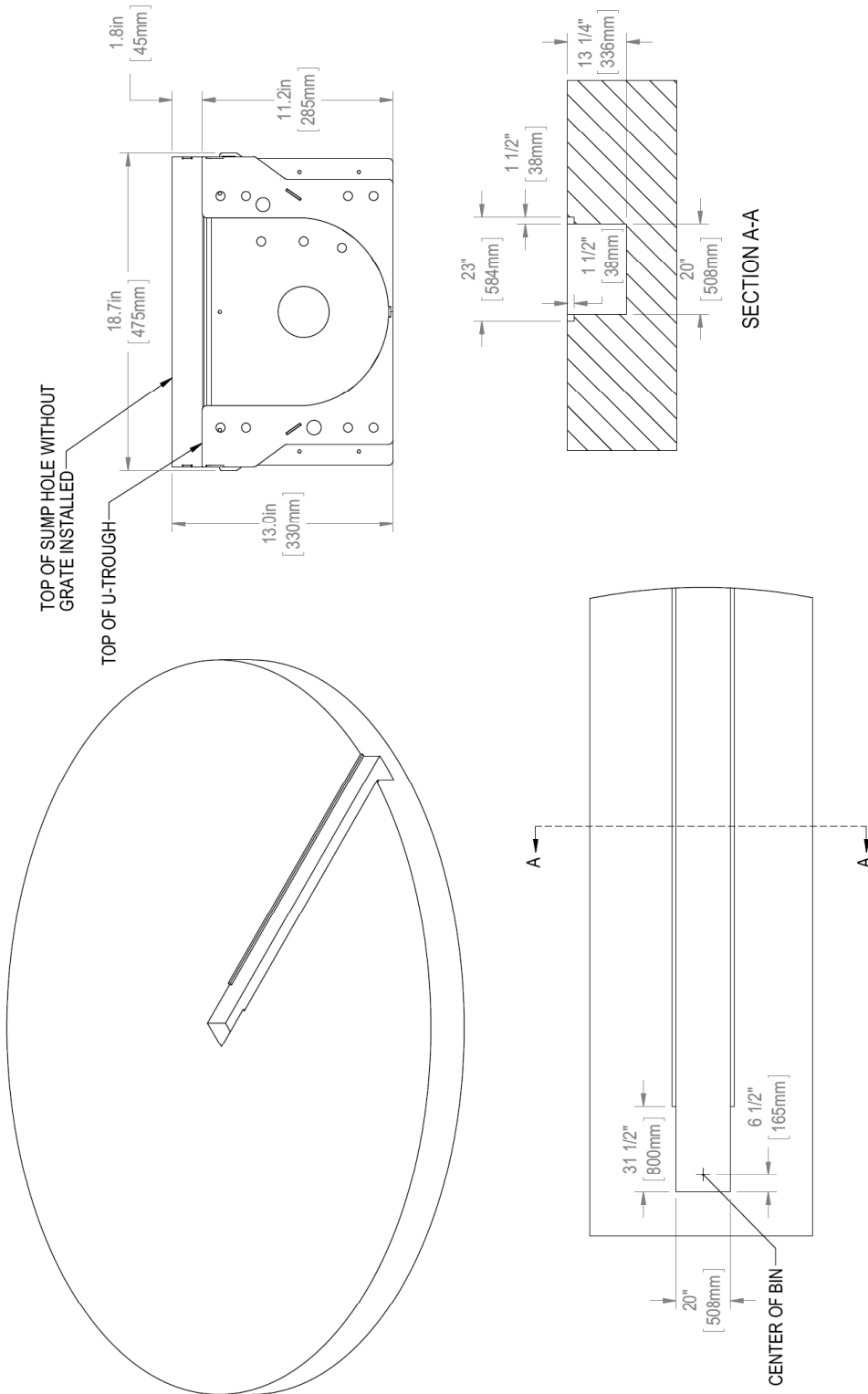

4.3. Bin Height

Follow the sections below for when installing in a full floor or partial floor aeration system.

Westeel Bins

➡ This section applies only to Westeel Bins.

The bin height requirements below must be met when installing a bin unload system in a Westeel bin with a full floor aeration system. If your bin height exceeds the maximum height for a given diameter, contact Westeel.

Table 5. Maximum Bin Heights for Bin Unload System Use

Bin Diameter (ft)	Max Number of Tiers
24	18
27	18
30	19
33	16
36	15
39	14
42	13
45	13
48	12
51	11
54	11
60	10

Other Branded Grain Bins

➡ This section applies to bins branded not as Westeel.

The underfloor auger requires spacing of floor supports no less than the requirements in the table below to clear floor supports.

Table 6. Minimum Floor Support Spacing for Underfloor Auger

High Output U-Trough Bin Unload System
17" Floor Support Spacing (center to center)

4.4. Bin Wall Cutout

An opening must be cut in the bin wall for the underfloor auger.

WARNING Cutting an opening in the bin can weaken the bin's structure and may lead to bin collapse if the instructions in this section are not accurately followed.

The Westeel EasyFlow2 High Output (100 Series) bin unload is intended to be installed in a Westeel grain bin. To install the bin unload in other bins, consult the manufacturer for specific details related to your bin.

For Westeel bins, follow the below when cutting the opening in the bin sidewall. For other bins, consult the bin manufacturer/dealer for specific details.

- Keep a minimum 45° angle between the center points of any two openings, such as an aeration fan (see [Figure 5 on page 22](#)).

Figure 5. Minimum Angle Between Openings

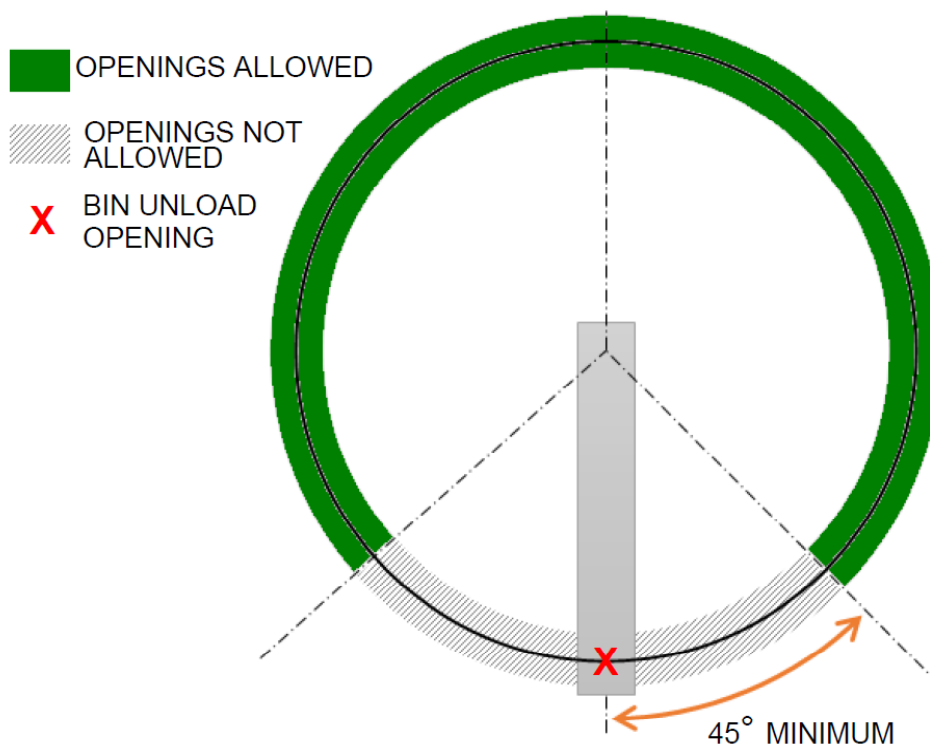

- Center the opening in the middle of the bin sheet, between two vertical bolt seams.
- Do not cut an opening through a vertical bolt seam between two sheets or a stiffener position.
- Cut the opening in a bin sheet at a location designated for discharge (see [Figure 6 on page 23](#)).
- The dimensions of the opening should measure 11" (279 mm) high x 15-1/4" (387 mm) wide. When measuring the opening, measure 11" (279 mm) from the bottom edge of the bottom wall sheet.
- Cut the opening as tight as possible for the underfloor auger to pass through and do not have more than a 1/4" (6 mm) gap to the auger joint flange on any side.
- The vertical flange of the bottom bin angle may be cut flush to the sides of the opening to allow the underfloor auger to fit through the opening.

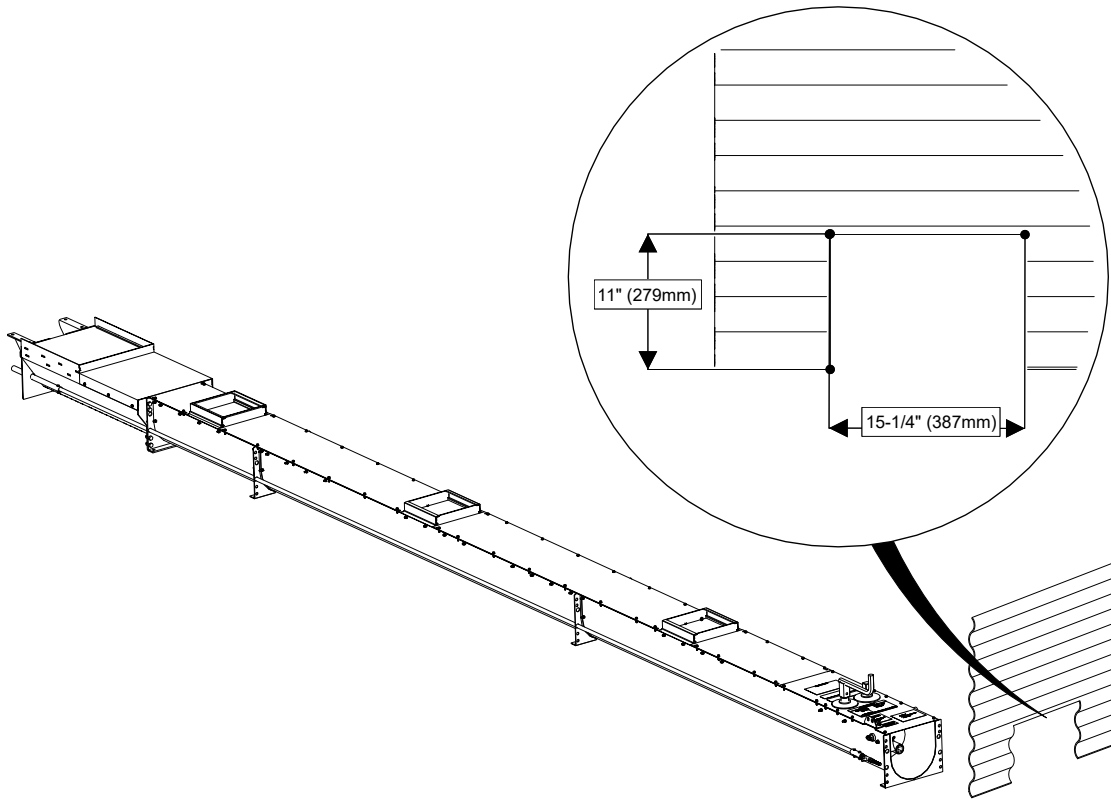
Figure 6. Bin Wall Cutout

4.5. Retrofit Information

When retrofitting the unload system into an existing bin:

1. Clean up and remove all settled grain dust deposits and ensure the air is nearly free of dust.



WARNING Sparks from grinding and hammer strikes which contact settled grain dust deposits or dusty air present a risk of explosion.

2. Temporarily remove the floor planks (if equipped) which will be used to cover the bin unload from the bin wall cutout to past the bin center point.

4.6. Installation Planning

Site planning should be performed prior to assembly and installation, including a bin site layout drawing (with dimensions), structural analysis, and consideration of suitability of connected equipment. Proper foundation design must be completed according to local building codes for full grain bin loading if the installer is planning to use the trench in the bin's concrete foundation floor as specified in this manual.

5. Pre-Assembly



Before continuing, ensure you have completely read and understood this manual's Safety section, in addition to the safety information in the section(s) below.

5.1. Check Shipment

Unload the bin unload parts at the assembly site and compare the packing slip to the shipment. Ensure that all items have arrived and that none are damaged. Take pictures of shipments prior to or just after unloading if there are any damaged parts.

Report missing or damaged parts immediately to ensure that proper credit is received from Westeel or your representative, and to ensure that any missing parts can be shipped quickly to avoid holding up the assembly process.

Important

Do not assemble or install damaged components.

5.2. Before You Begin

Before you assemble the bin unload:

- Familiarize yourself with all the sub-assemblies, components, and hardware that make up the equipment.
- Have all parts and components on hand, and arrange them for easy access.
- Separate the hardware (bolts, nuts, etc.) and lay them out into groups for easier identification during assembly.

5.3. Required Materials

These materials are not supplied and must be purchased separately:

- shim steel of various thicknesses
- four 1/2" concrete anchor bolts (for anchoring the underfloor auger to the floor) (see [Figure 7](#) and [Figure 8](#)).

Figure 7. Wedge Concrete Anchor Bolt



Figure 8. Epoxy Bonding Concrete Anchor Bolt



- 2 corrugated sponge strips (for bin adapter)

- outdoor-rated, ultraviolet-resistant spray foam (for bin adapter)
- silicon sealant or neoprene rubber (for sealing around lip of each sump to floor planks across the underfloor auger)
- electric motor (including hardware) (see [Table 8 on page 69](#) for horsepower requirements)
- triple-groove motor pulley (see [Table 9 on page 69](#) for size recommendations)
- three B65 belts

5.4. Required Lifting Equipment

Use proper lifting equipment rated to lift the underfloor auger assembly (see weights in [Table 7](#)).

Figure 9. Underfloor Auger (As-Shipped)

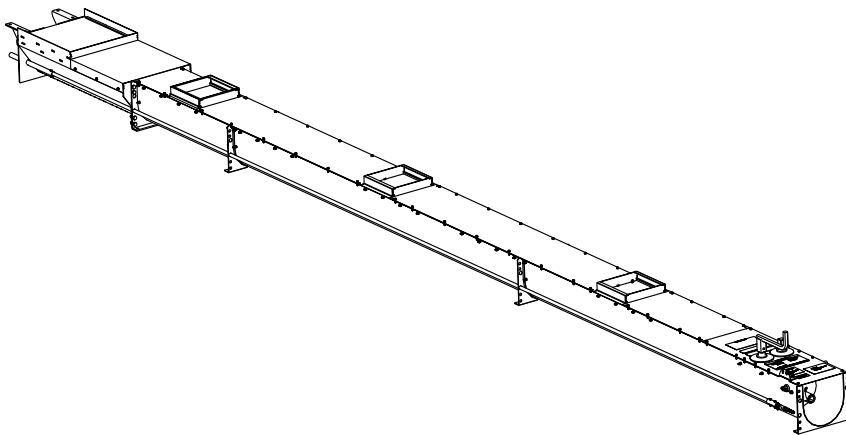

Table 7. Underfloor Auger Weight

Bin Unload Model (Bin Diameter)	Underfloor Auger Weight
24'	452 lb (205 kg)
27'	481 lb (218 kg)
30'	575 lb (261 kg)
33'	604 lb (274 kg)
36'	639 lb (290 kg)
39'	668 lb (303 kg)
42'	701 lb (318 kg)
45'	725 lb (329 kg)
48'	793 lb (360 kg)
51'	820 lb (372 kg)
54'	848 lb (385 kg)
60'	914 lb (415 kg)

5.5. Required Tools

The following tools are required to assemble the bin unload system:

- angle grinder with grinding disc (for cutting bin wall opening, sump openings in aeration planks)
- impact wrench (with full set of SAE sockets)
- full set of SAE hand wrenches
- full set of SAE Allen keys
- 40' (12 m) tape measure
- hand tools (hammer, punches, etc.)
- one 25" (635 mm) straight edge
- five to ten 1/4" wood blocks
- work lights
- one floor dolly

6. Assembly



Before continuing, ensure you have completely read and understood this manual's Safety section, in addition to the safety information in the section(s) below.

6.1. Assembly Safety

WARNING

- Do not take chances with safety. The components can be large, heavy, and hard to handle. Always use the proper tools, rated lifting equipment, and lifting points for the job.
- Carry out assembly in a large open area with a level surface.
- Always have two or more people assembling the bin unload.
- Make sure you have sufficient lighting for the work area.
- Tighten all fasteners according to their specifications. Do not replace or substitute bolts, nuts, or other hardware that is of lesser quality than the hardware supplied by the manufacturer.

6.2. Bin Floor Preparation

1. Locate the center of the bin by measuring and drawing horizontal lines across the bin (see [Figure 10 on page 28](#)).

Important

The center point must be found accurately to ensure that the sweep does not interfere with the bin wall.

2. The vertical gearbox shaft in the center sump is aligned with the bin center point later in the assembly.

Note

The aeration floor planks should not be installed until the underfloor auger is installed.

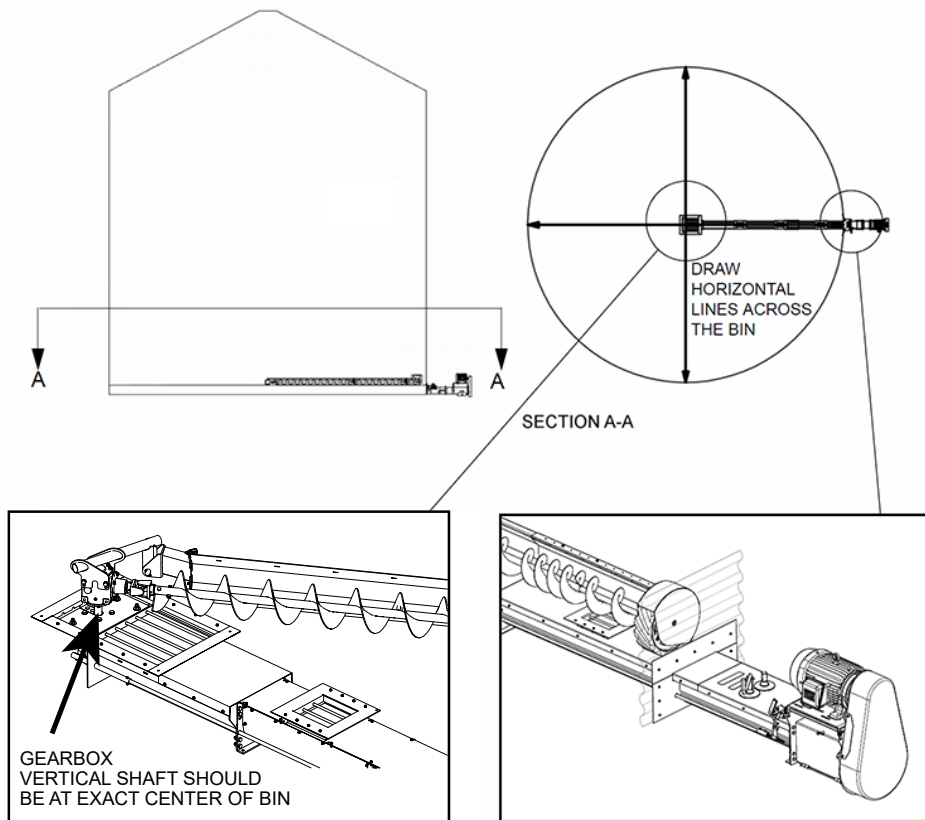
Figure 10. Locating the Bin Center

6.3. Positioning the Underfloor Auger

If you are installing the underfloor auger **before** completion of the sidewall and anchoring the bin to the foundation:

- Move the underfloor auger into nearly its final position in the bin before the final sidewall tier is complete.
- Cut an opening in the appropriate bin sheet before the sheet is installed (see [Section 4.4 – Bin Wall Cutout on page 22](#)).
- After the bin sidewall has been completed and anchored to the foundation, according to the principles given in [Section 6.3.1 – Removing the Bin Sheet on page 28](#), perform final positioning and leveling of the underfloor auger, installing the anchor legs, and anchoring the underfloor auger.

If you are installing the underfloor auger **after** anchoring the bin sidewall to the foundation, follow either [Section 6.3.1 – Removing the Bin Sheet on page 28](#) or [Section 6.3.2 – Cutting a Bin Sheet in Place on page 30](#) according to the conditions given within those sections.

6.3.1 Removing the Bin Sheet

This procedure describes removing a bin sheet after the bin sidewall has been anchored to the foundation and applies to the installation of the underfloor auger **below the main door in a Westeel or Twister bin only**. You **must receive written permission from your bin manufacturer** if you want to use this procedure for:

- removing sidewall sheets other than below the main door for Westeel or Twister bins, or
- removing any sidewall sheets for bin manufacturers other than Westeel or Twister.

1. With the bin secured to the foundation, remove the bottom spacer sheet below the door by removing the 3/8" x 1-1/2" bolts and nuts (see [Figure 11](#)).

Figure 11. Spacer Sheet

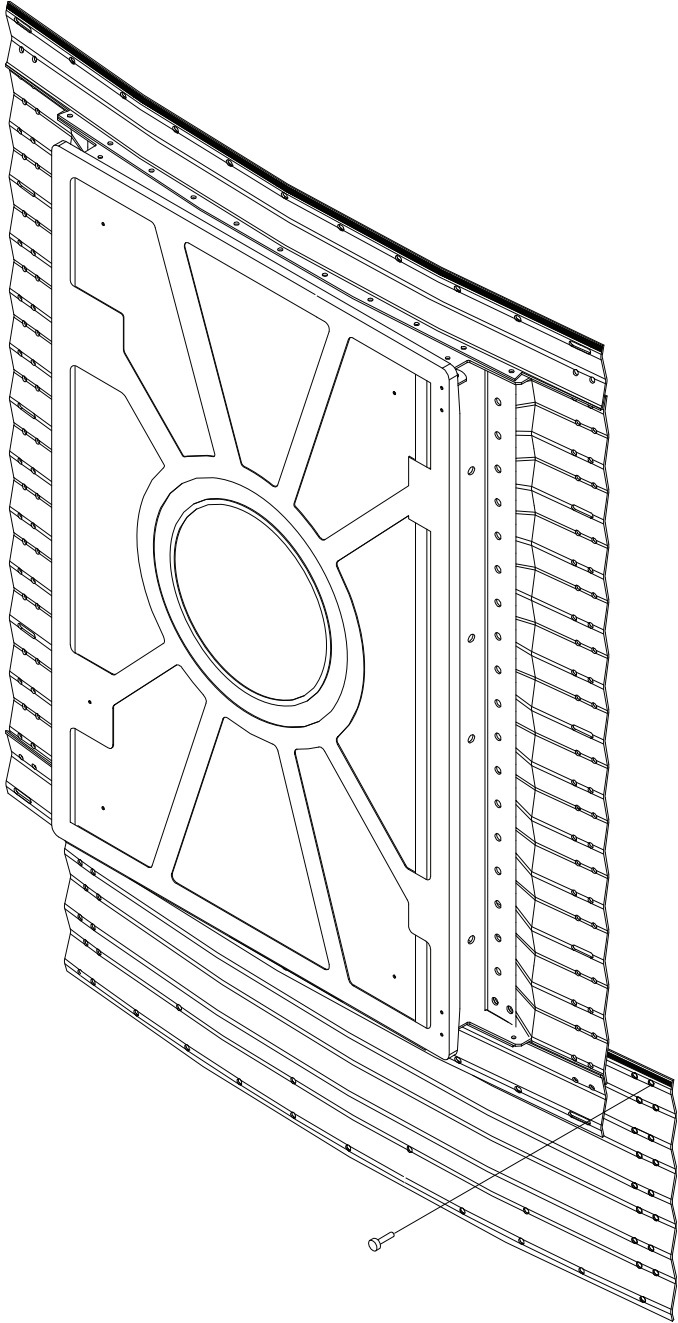

2. Slide the underfloor auger through the space underneath the bin door and place it in the approximate location.
 3. Cut an opening in the bottom spacer sheet (refer to [Section 4.4 – Bin Wall Cutout on page 22](#)).
- Go to [Section 6.6 – Install the Bin Adapter on page 41](#).

6.3.2 Cutting a Bin Sheet in Place

This procedure describes cutting the opening for the underfloor auger with the sheet in place after the bin sidewall has been anchored to the foundation. This procedure requires some disassembly and reassembly of components in order to install the underfloor auger. This procedure is allowed for use with all bin manufacturers and for any appropriate sidewall sheet at the bin bottom (under the door and elsewhere).

Position the Underfloor Auger on the Bin Floor

Lift the underfloor auger and place it on the bin floor. Use proper lifting equipment (see [Section 5.4 – Required Lifting Equipment on page 25](#)).

Note

The bin unload does not need to be located at the center point of the bin at this stage of assembly.

Remove the Lower Gearbox Controls

Remove the lower gearbox controls to allow for the underfloor auger to clear the bin wall cutout and to enable the bin adapter to slide over the lower gearbox control rod.

1. Pull the gearbox shift lever (1) away from the center sump and remove the 1/4" x 1-1/2" bolts (2) and nylon locknuts (3) from the coupler (4) of the lower gearbox control rod (see [Figure 12](#)). Push the gearbox shift lever toward the center sump to allow the control rod to come out of the coupler.

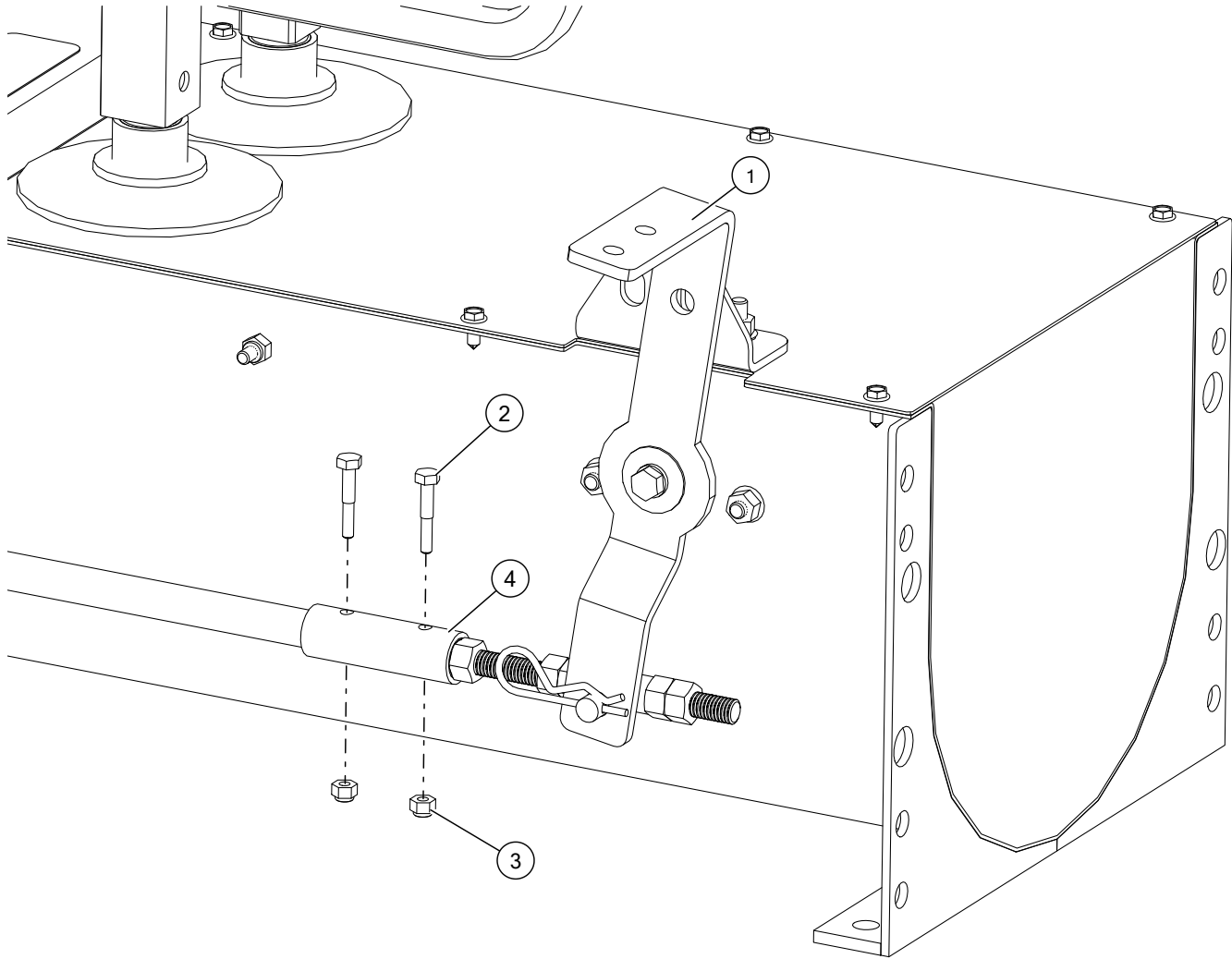
Figure 12. Unfasten the Coupler from the Gearbox Control Rod

2. Remove the cotter pin (5) from the gearbox shift adjust tube (6) and remove the coupler assembly from the gearbox shift lever (1) (see [Figure 13 on page 32](#)).

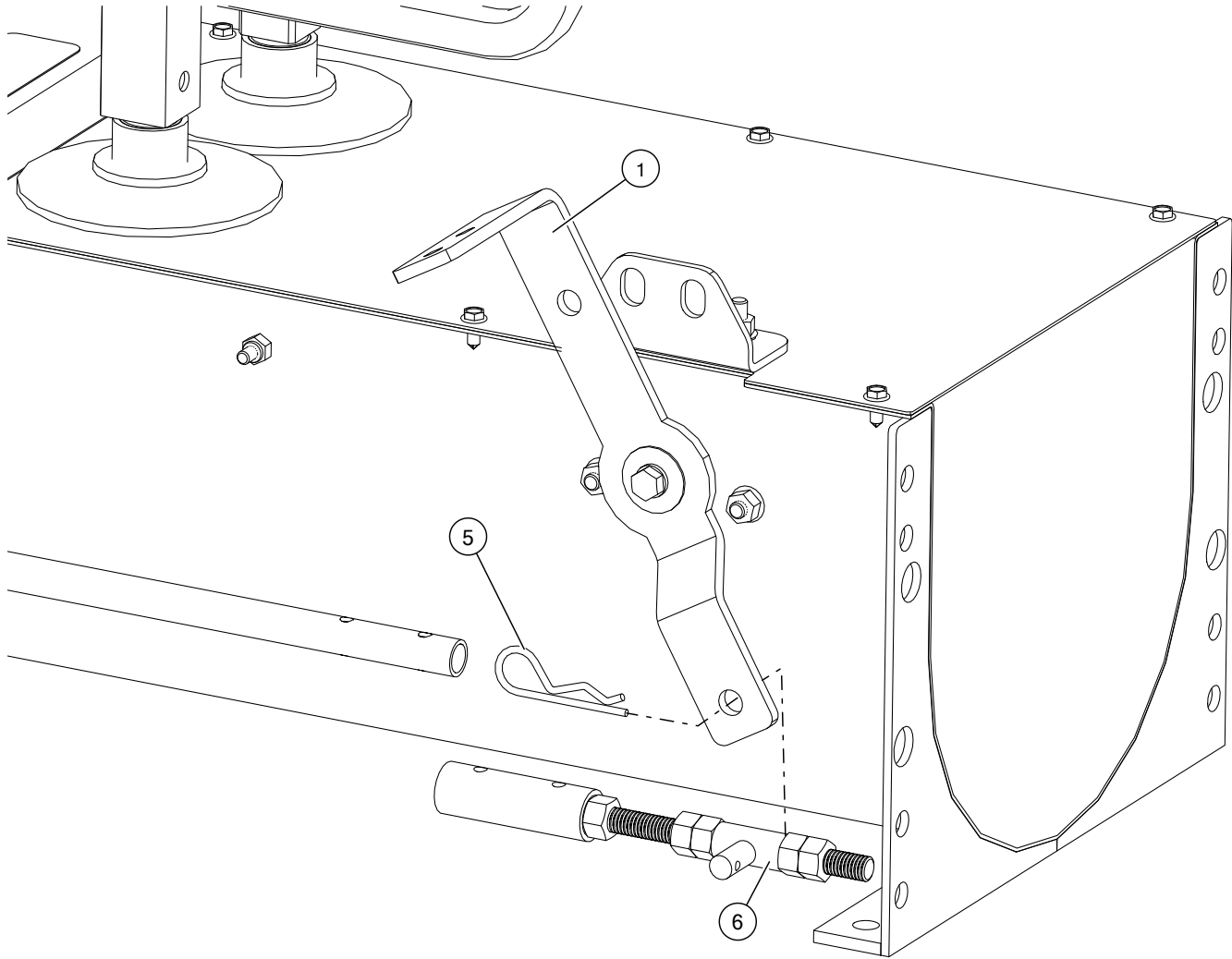
Figure 13. Remove the Coupler Assembly from the Gearbox Shift Lever

3. Remove the 3/8" x 1" bolt (7), lock washer (8), and flat washer (9) from the gearbox shift lever (1). Remove the gearbox shift lever by lifting it straight upward (see [Figure 14 on page 33](#)).

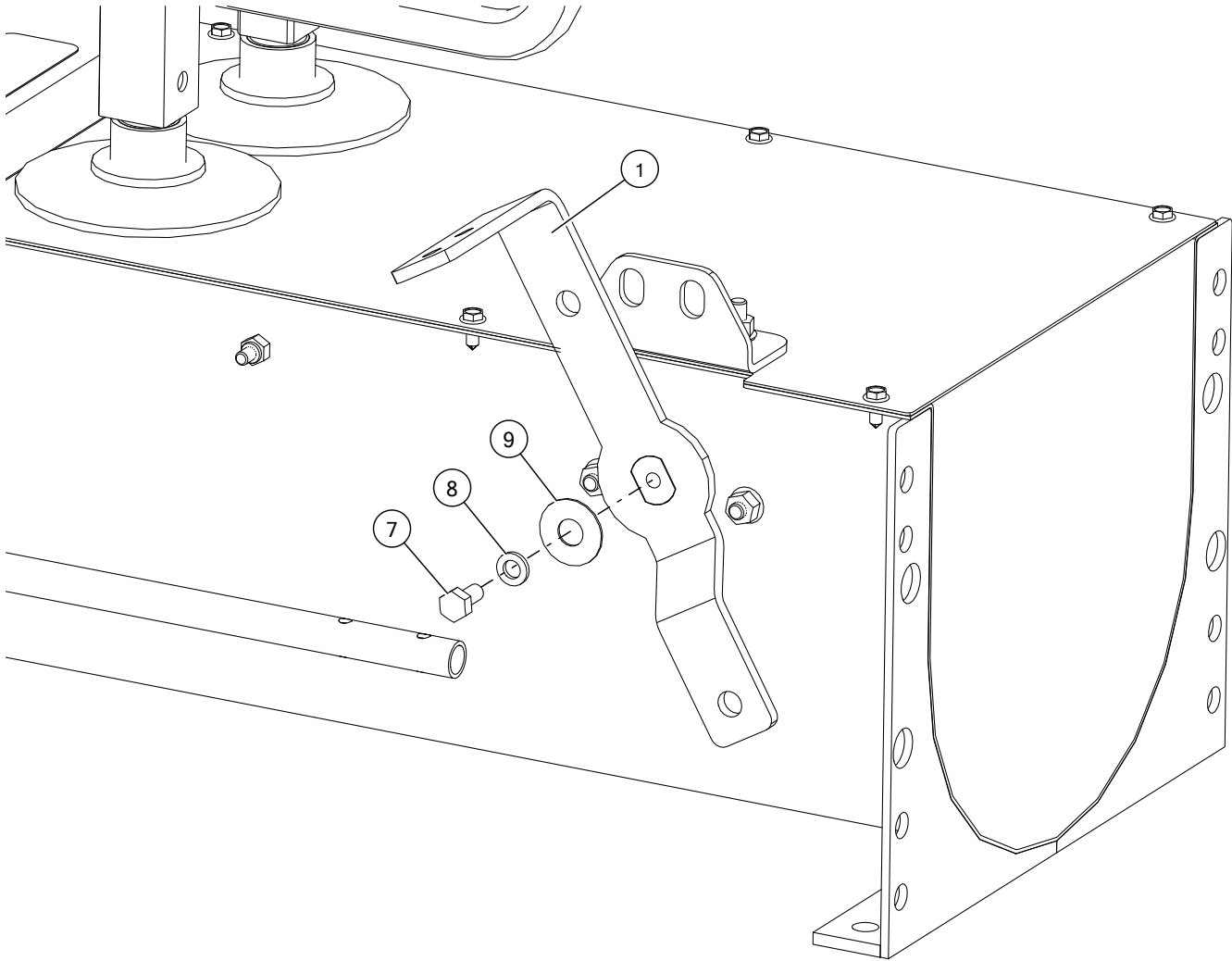
Figure 14. Remove the Gearbox Shift Lever**Remove the Sump Controls**

Removing the sump controls allows sufficient clearance for the underfloor auger to slide out through the bin wall cutout.

1. Remove the dust seals (1), eight #14 x 1/2" self-tapping screws (2), and control cover (3) (see [Figure 15 on page 34](#)).

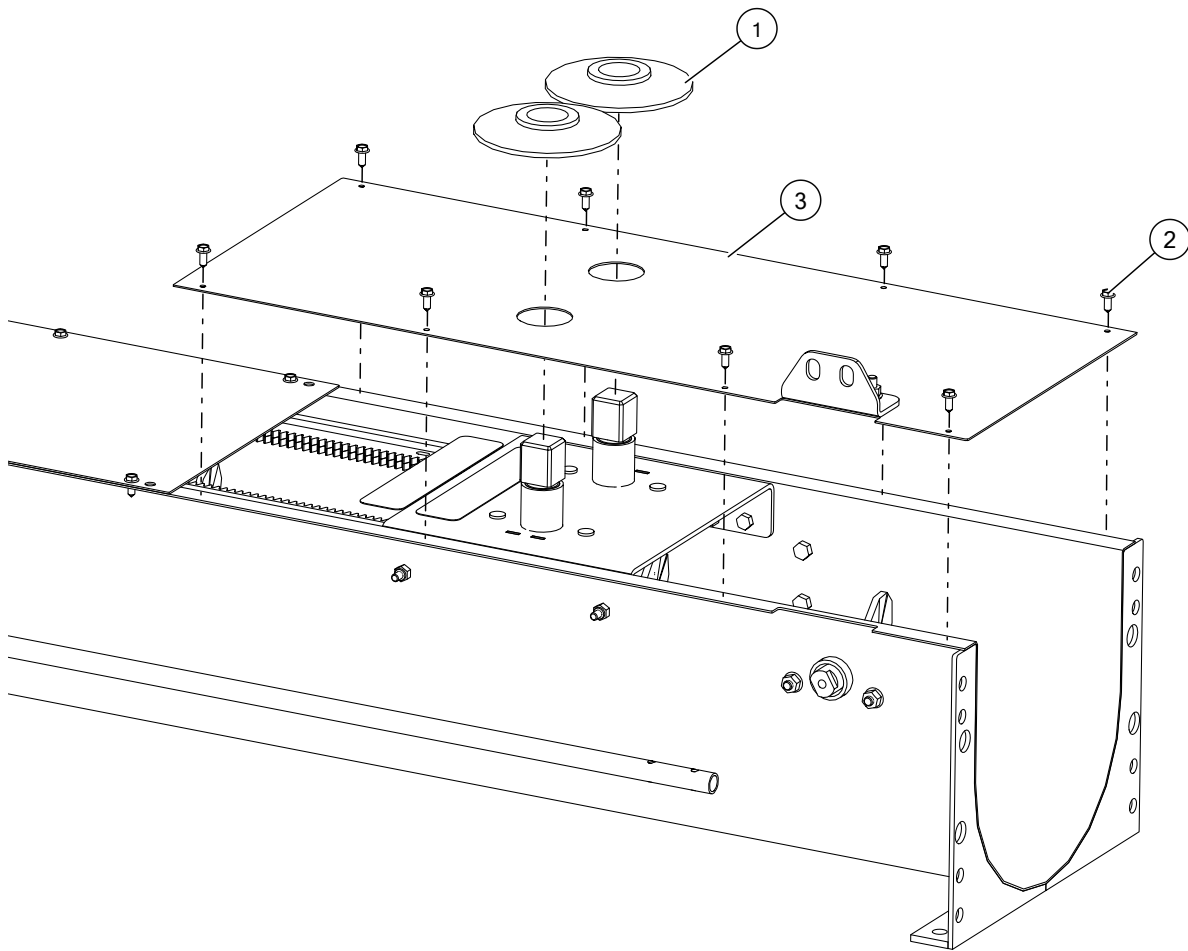
Figure 15. Control Cover Disassembly

2. Remove the 1/4" x 3/4" bolt (4) and washer (5), and the control knob/shaft (6). Do this for both control knobs/shafts (see [Figure 16 on page 35](#)).

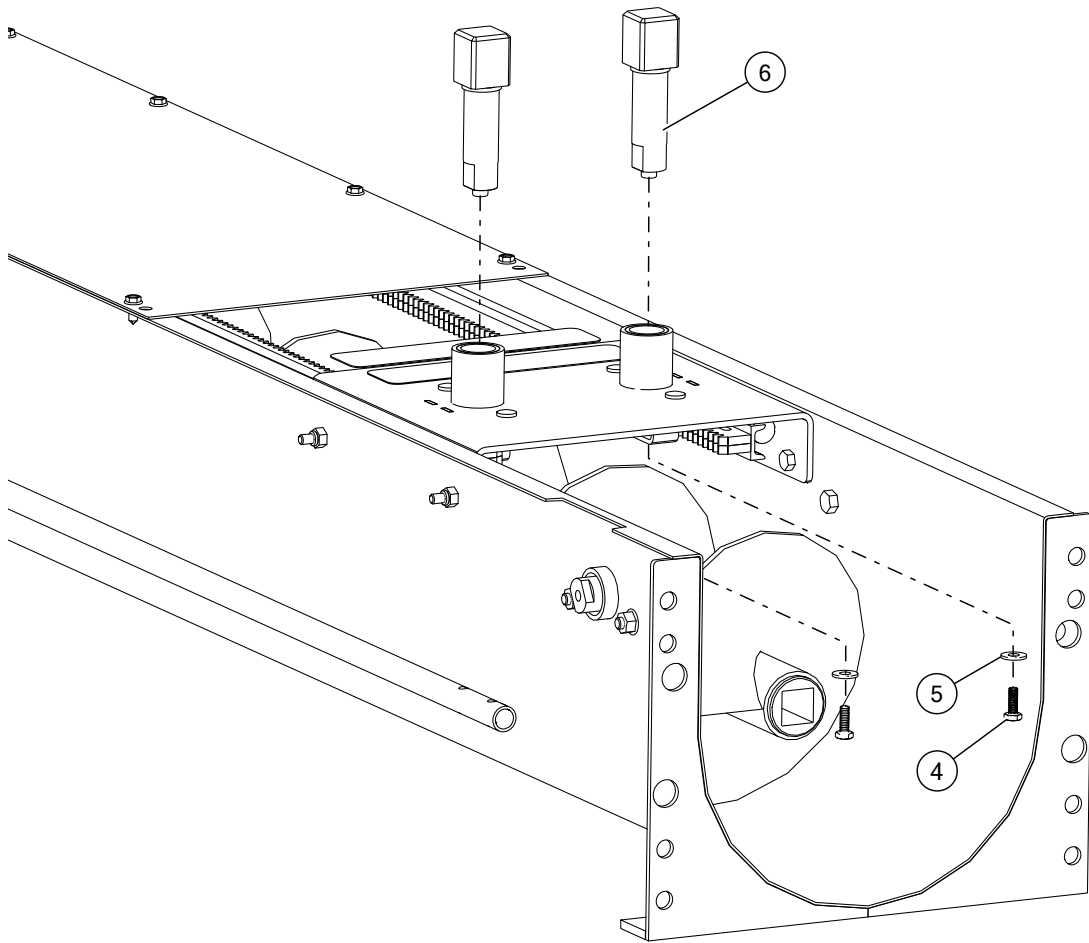
Figure 16. Remove the Sump Control Knob/Shafts

3. Remove the pinion gears (7) and washers (8) for each control knob/shaft (see [Figure 17 on page 36](#)).

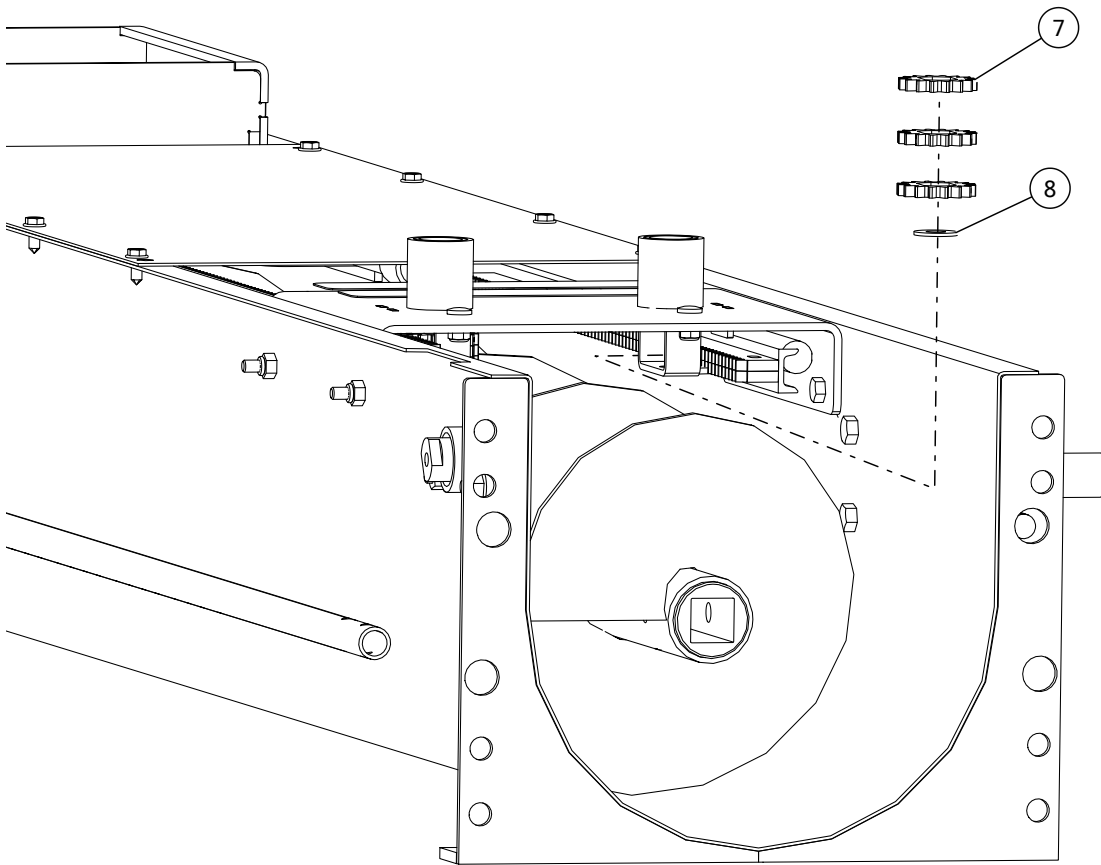
Figure 17. Remove the Pinion Gears**Remove the E-Sump Controls**

The following disassembly step allows sufficient clearance for the underfloor auger to slide out through the bin wall cutout.

Remove the two 1/4" x 1-1/2" bolts (1), nylon locknuts (2), and handle (3) from the control rod (see [Figure 18 on page 37](#)).

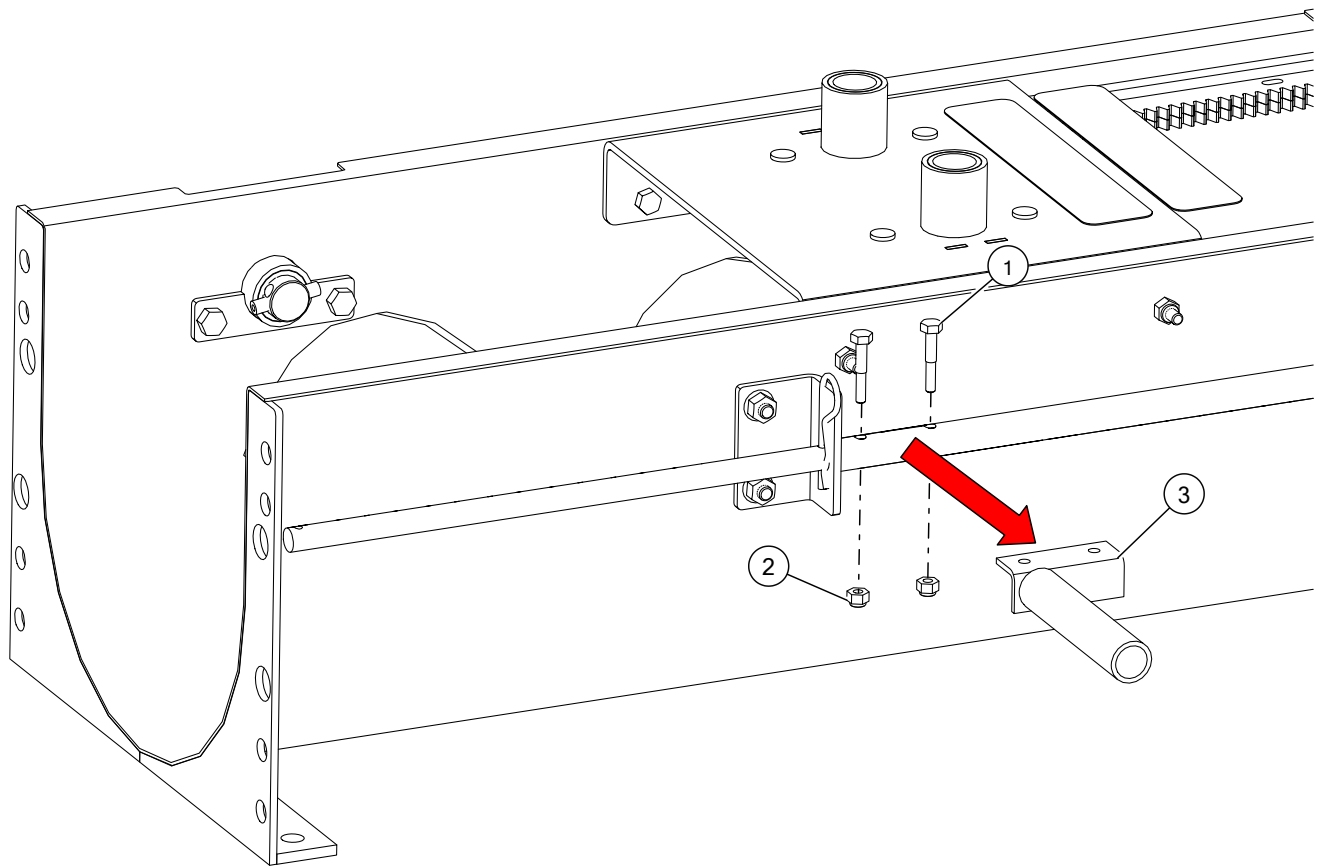
Figure 18. Remove the Handle**Position the Underfloor Auger**

1. Cut an opening in the appropriate bin sheet (see [Section 4.4 – Bin Wall Cutout on page 22](#)).
2. Slide the underfloor auger through the bin wall cutout and place it in the approximate location.

6.4. Install Tandem Gearboxes in the Center Sump

1. Confirm each gearbox is filled with gear oil.

Note

Gearboxes are supplied from the factory with EP90 gear oil up to the vented fill plug. Keep the tandem gearboxes level when filling or checking the oil level, as shown in [Figure 19 on page 38](#).

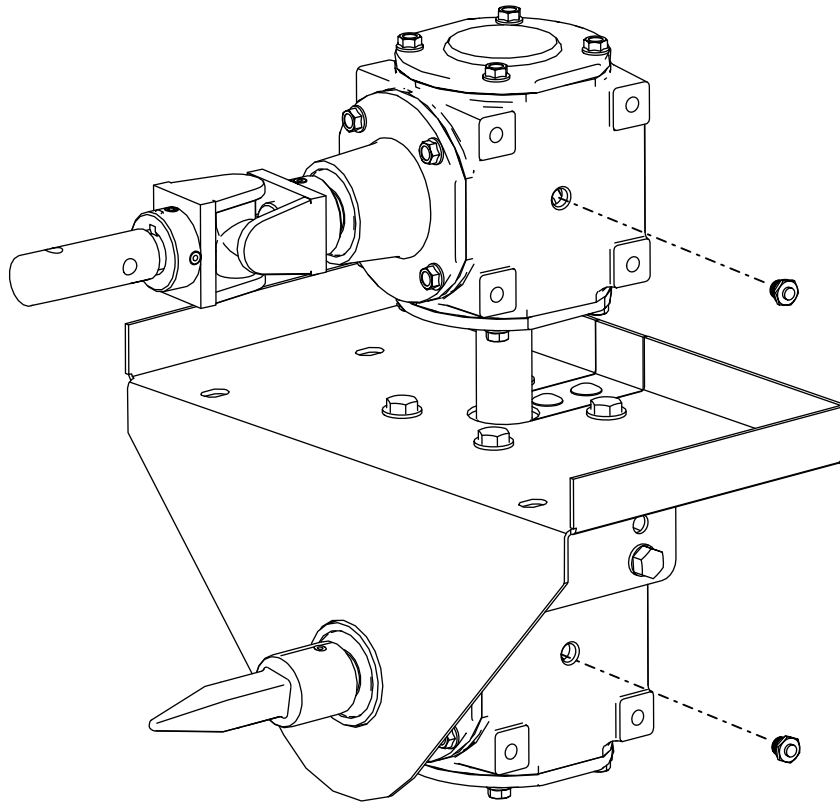
Figure 19. Check the Oil Level

2. Fully open the center sump gate.
3. Put gearbox shifter in the forward position (as far towards the shaft side as possible).

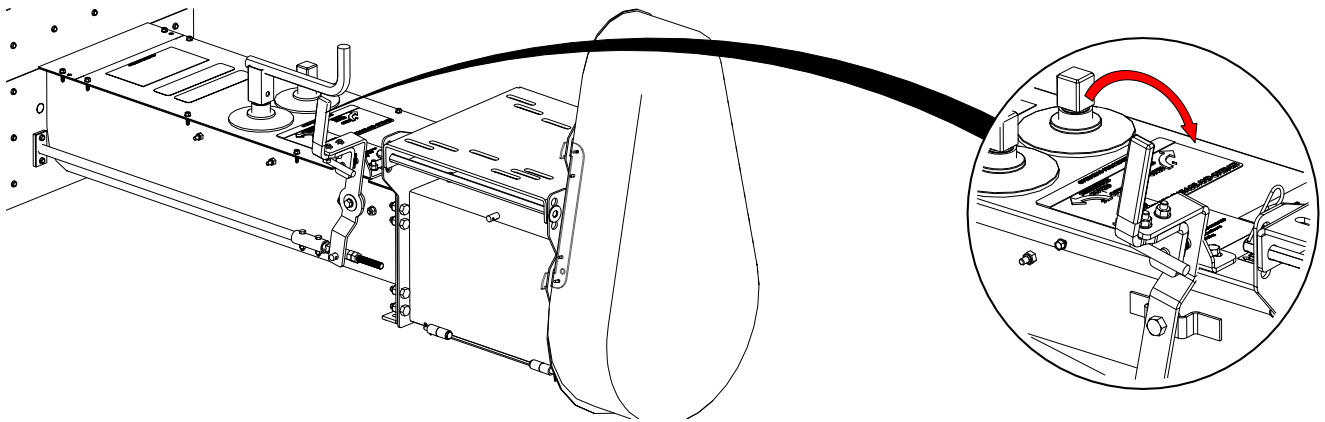
Figure 20. Gearbox Shifter in the Forward Position

4. Position the shifter linkage in the trough so that it will align with the gearbox shifter.
5. Lower the gearbox (1) into the trough, making sure that the front cover (2) is on the outside of the gearbox partition (3).

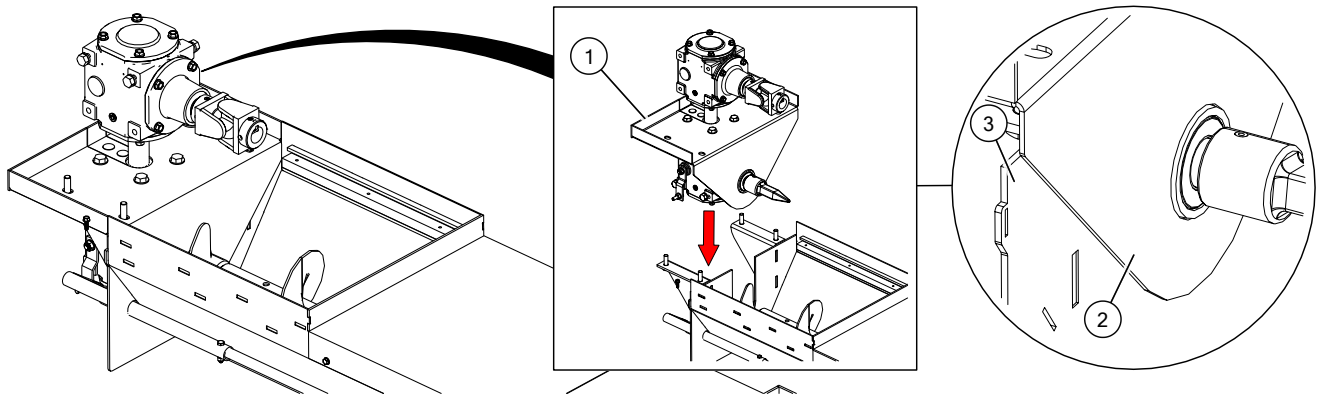
Figure 21. Lower the Gearbox into the Trough

6. Slide the gearbox linkage bolt through the slot in the shifter control rod bracket.

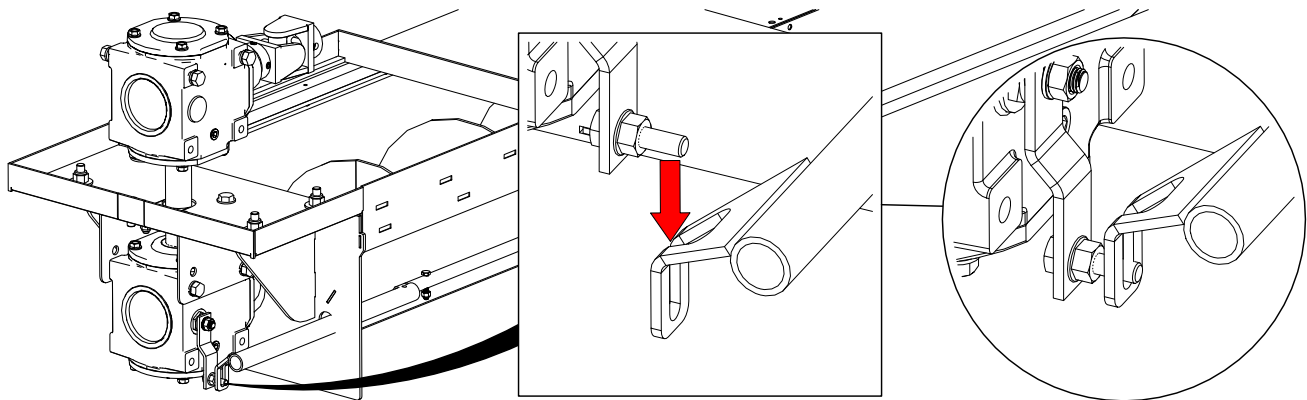
Figure 22. Slide Bolt through Shifter Linkage Slot

7. Push the gearbox as far back as possible to seal any small gap between the front cover and gearbox partition.

8. Secure with 1/2" washers and locknuts.

9. Optional: Seal any gaps with silicone to ensure complete seal.

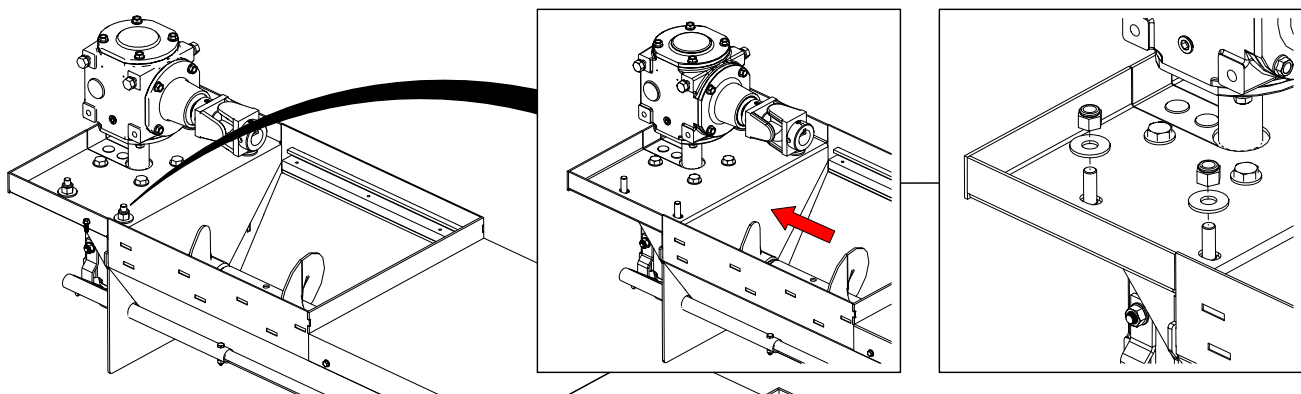
Figure 23. Install Tandem Gearboxes into Center Sump

10. Ensure the tandem gearboxes are vertically aligned.

11. Test gearbox for engagement: Move the gearbox shift handle to the engaged position (B) and pin in place (see [Figure 24](#)). Turn the upper gearbox horizontal shaft and confirm the lower gearbox horizontal shaft will rotate. If the lower gearbox horizontal shaft rotates, the gearbox is properly engaged.
12. Test gearbox for disengagement: Move the gearbox shift handle to the disengaged position (A) and pin in place. Turn the upper gearbox horizontal shaft. The lower gearbox horizontal shaft should **NOT** rotate. If the lower gearbox horizontal shaft does not rotate, the gearbox is properly disengaged.
13. Using the gearbox shift handle, engage/disengage the gearbox multiple times to verify normal working operation.

Figure 24. Moving the Gearbox Shift Handle

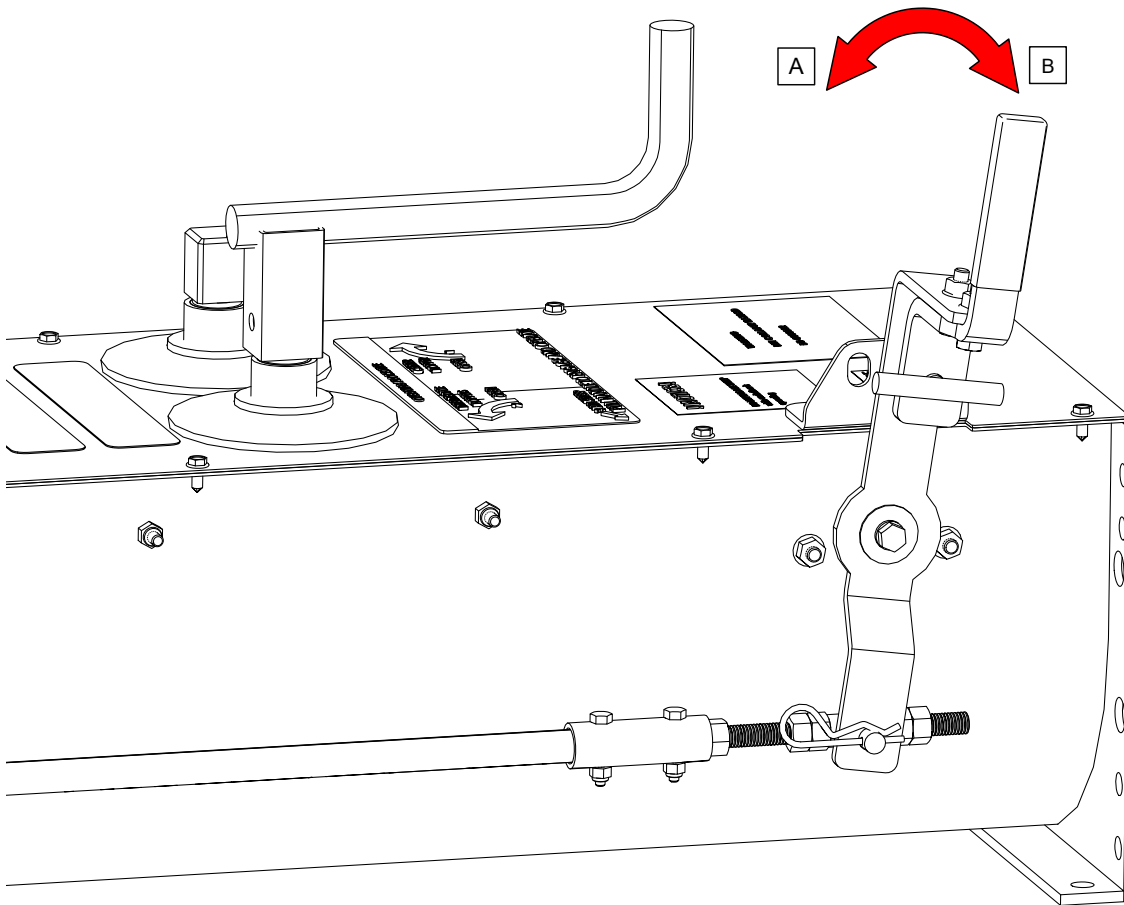

6.5. Install the Underfloor Auger

1. Align the center sump vertical gearbox shaft exactly at the bin centerpoint (C) (refer to [Section 6.2 – Bin Floor Preparation on page 27](#)).
2. Level the underfloor auger using shims (not supplied) at every floor mount bracket. The underfloor auger must be level within 1/4" (6 mm) per 10' (3048 mm) of span or not more than 1/2" (13 mm) for whole underfloor auger. This will prolong life and ensure smooth operation.

3. Install the anchor legs to the underfloor auger using the existing 1/2" x 1-1/4" bolts and locknuts used in the joint connections. Install two legs at the auger joint nearest the center sump. Install two legs at the auger joint inside the bin nearest the bin wall (see [Figure 25 on page 41](#)).

Figure 25. Install Underfloor Auger in Position

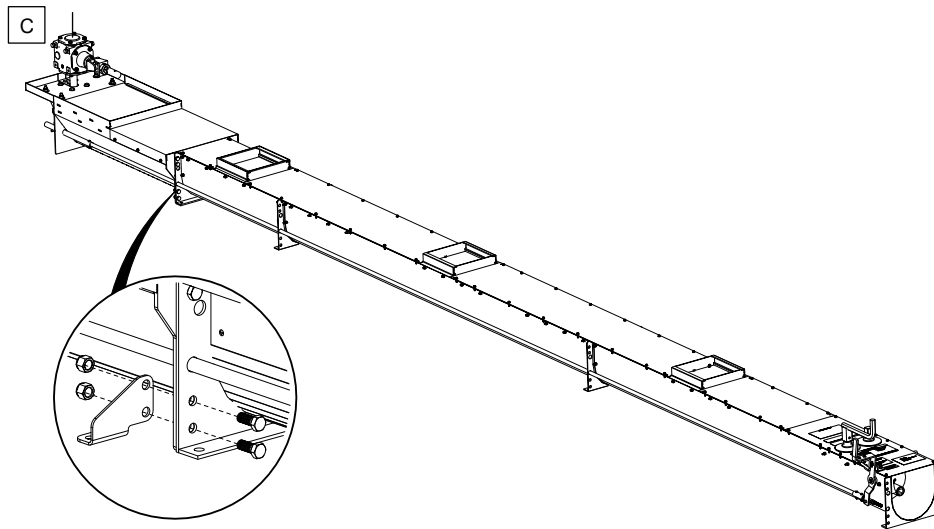

4. Anchor the underfloor auger to the bin floor using concrete anchor bolts through the holes in the bottom of the anchor legs. The anchor bolts are purchased separately according to type (see [Section 5.3 – Required Materials on page 24](#)).
5. **This step only required for underfloor augers where the bin sheet was removed (see [Section 6.3.1 – Removing the Bin Sheet on page 28](#)).** Slide the spacer sheet over top of the unload and re-attach to the bin door using the existing 3/8" x 1-1/2" bolts and nuts.

6.6. Install the Bin Adapter

Note

The bin adapter creates a seal to minimize aeration and heat losses (when applicable) and keeps snow and rodents out.

- ➔ 1. **For a Westeel or Twister bin:** If not done so already, pull the gearbox shift lever (1) away from the center sump and remove the 1/4" x 1-1/2" bolts (2) and nylon locknuts (3) from the coupler (4) of the lower gearbox control rod (see [Figure 26 on page 42](#)). Push the gearbox shift lever toward the center sump to allow the control rod to come out of the coupler.

Figure 26. Unfasten the Coupler from the Gearbox Control Rod

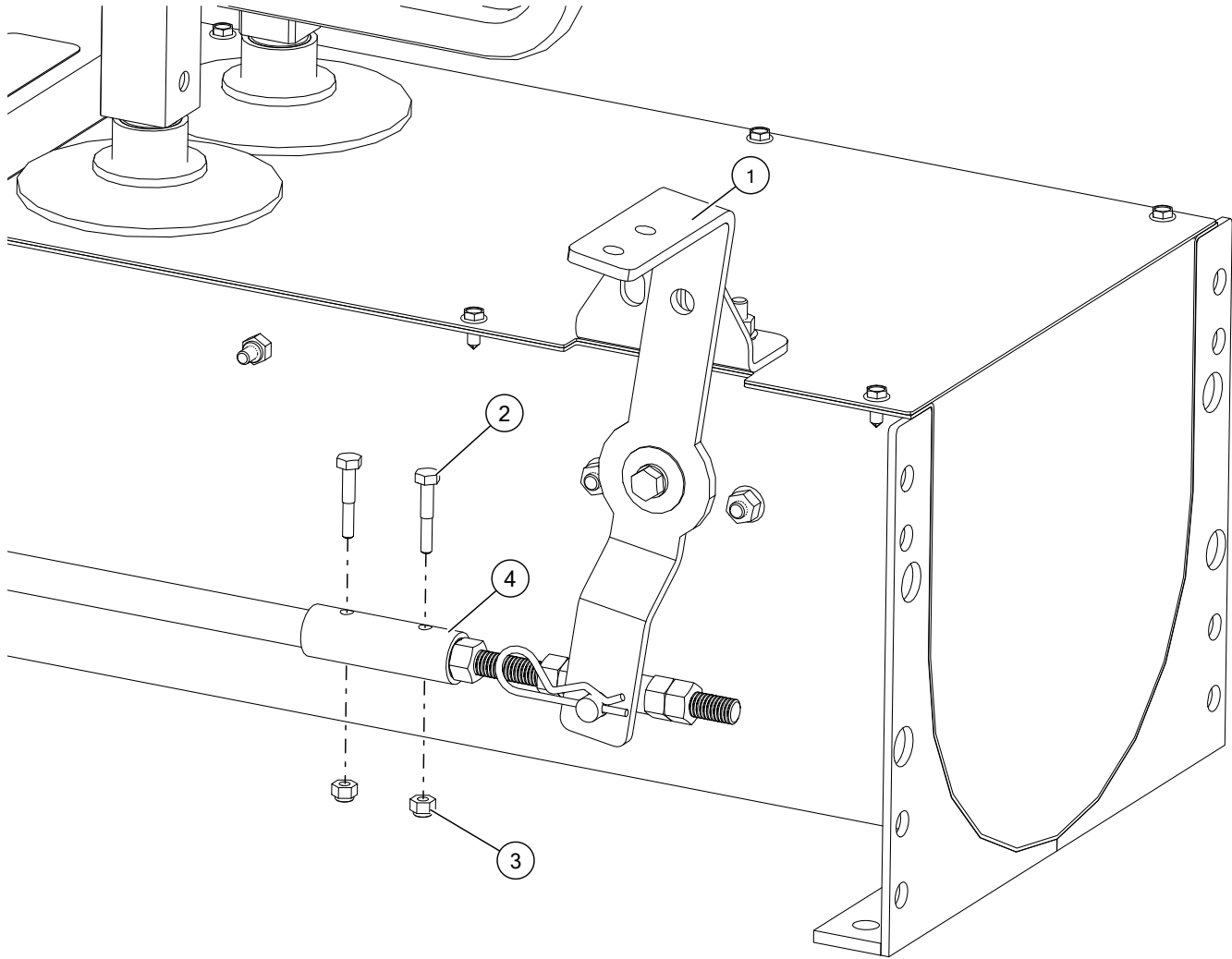

2. Before installing the bin adapter pieces, pop out the control rod holes (as noted below).

Figure 27. Control Rod Holes in Bin Adapter Piece

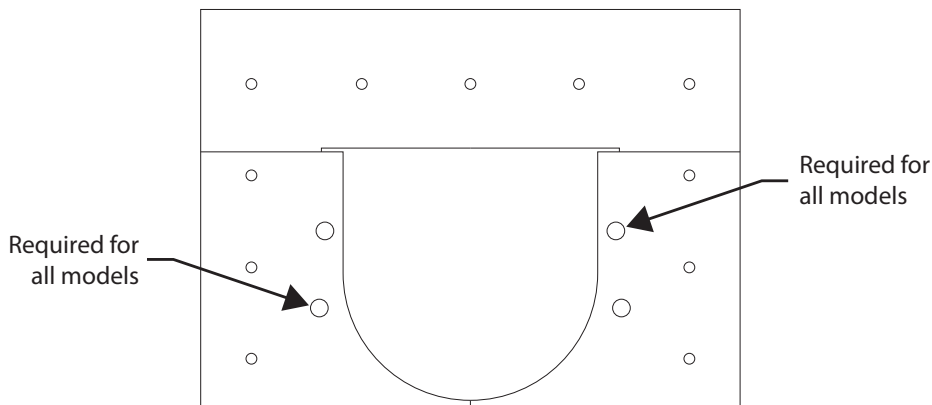

3. Slide the bin adapter piece onto the lower gearbox control rod and up against the bin wall (see [Figure 28 on page 43](#)).

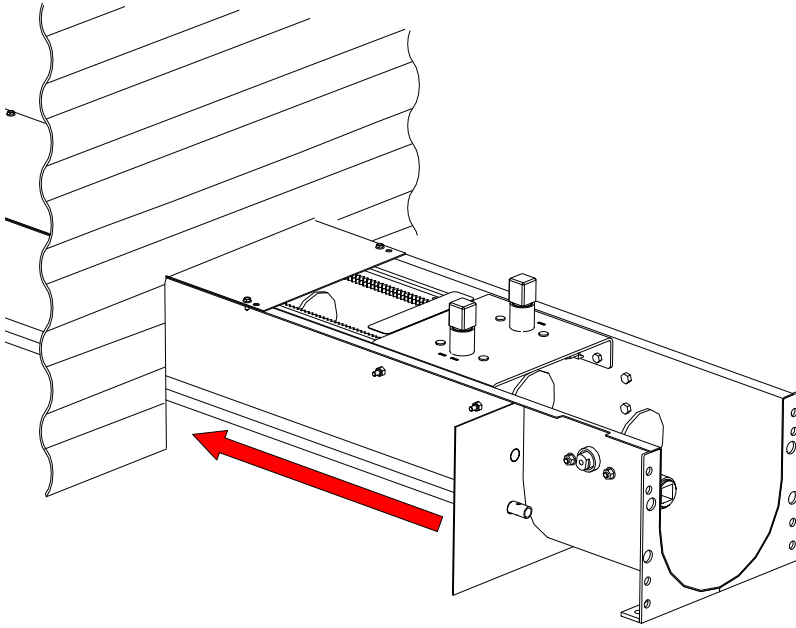
Figure 28. Slide Bin Adapter Piece on Lower Gearbox Control Rod

4. Slide the bin adapter piece on the side of the high output u-trough and up against the bin wall (see [Figure 29](#)).

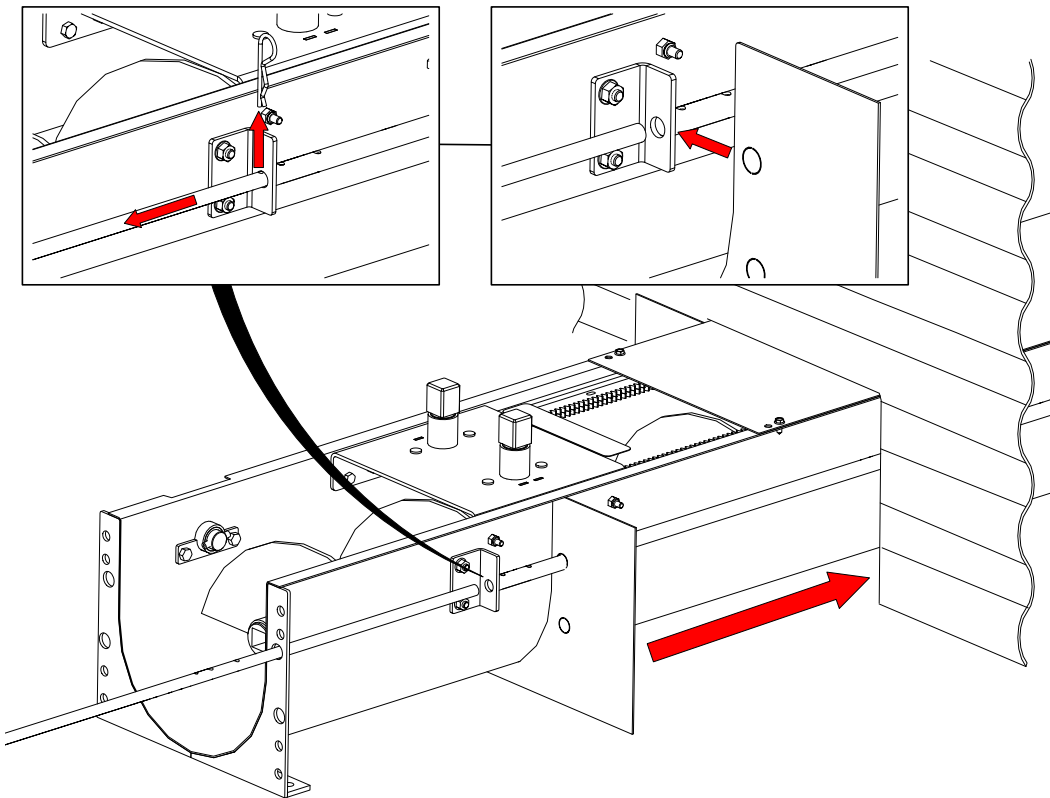
Figure 29. Slide Bin Adapter Piece

5. Place the top piece behind the bin adapter lower pieces (see [Figure 30 on page 44](#)).

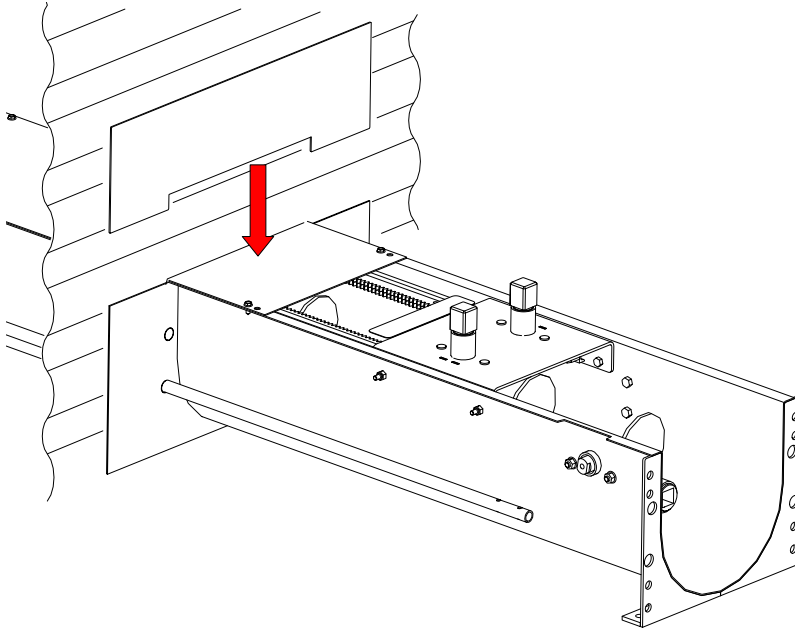
Figure 30. Position Bin Adapter Top Piece

6. Push the bin adapter pieces up against the bin wall. Two corrugated sponge strips (not supplied) can be arranged as shown in [Figure 31](#).

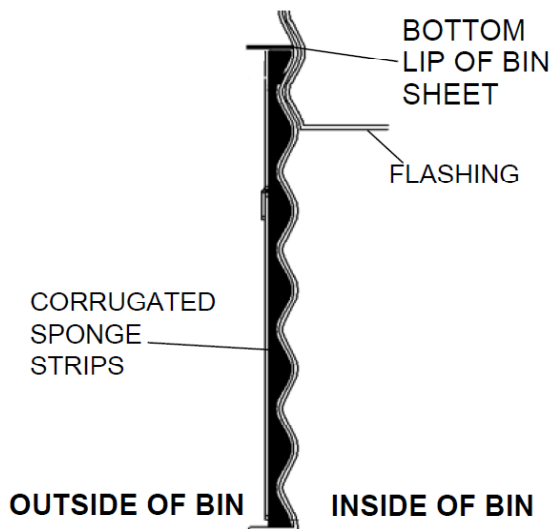
Figure 31. Sponge Strips**Important**

Ensure that center sump, e-sump, intermediate sumps, and bin adapter are all level with each other during installation.

7. Securely fasten the bin adapter pieces to the bin wall using the eleven #14 x 1" self-tapping screws provided (see [Figure 32 on page 45](#)). Fasten the screws to the "hills" in the corrugations on the bin wall sheet.
8. Attach the gasket (1) and flashing plate (2) over the control rod (as well as the e-sump control rod) in the bin adapter pieces using the #14 x 1" self-tapping screws (3) (see [Figure 32 on page 45](#)).

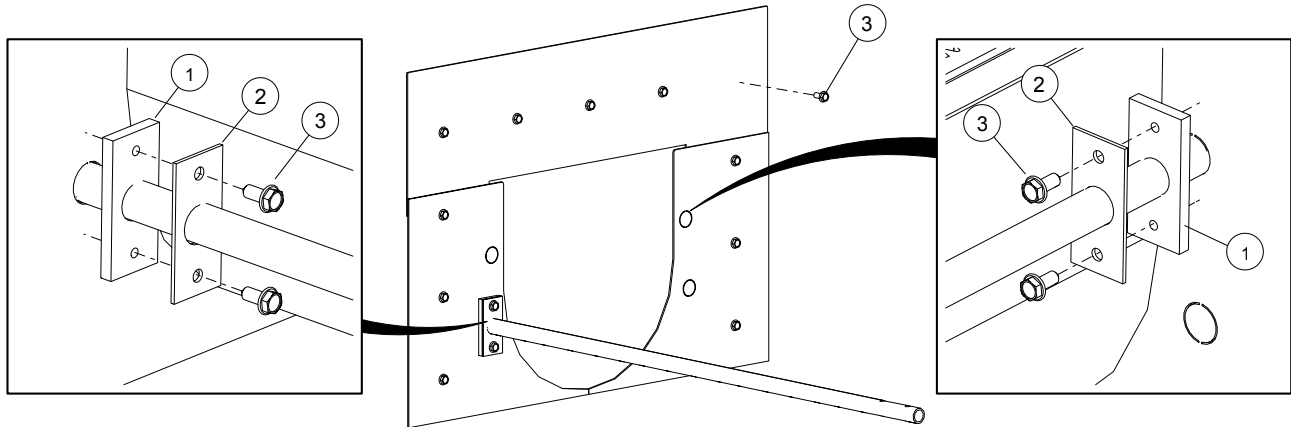
Figure 32. Screwing Bin Adapter Pieces

9. Apply spray foam (purchased separately) in the following locations for sealing:
- Along the top and bottom seams of the bin adapter where it meets the bin wall.
 - If necessary, along the sides for further sealing in addition to the corrugated sponge strips.
 - Along the seam of the underfloor auger cover where it meets the bin adapter top piece.
 - Along the seam of the underfloor auger where it meets the bin adapter lower pieces.

6.7. Reassemble the E-Sump Controls

If the e-sump controls were previously disassembled, reassemble them by following the reverse order of steps and ensure all bolts and nuts are tight.

6.8. Reassemble Sump Control Knobs

If the sump control knobs/shafts were previously disassembled, reassemble them by following the reverse order of steps and ensure all bolts and nuts are tight.

6.9. Reassemble Lower Gearbox Controls

1. To reassemble the lower gearbox controls, follow the reverse order of steps used to disassemble and ensure all bolts and nuts are tight.
2. Assemble the gearbox shift handle (4) onto the gearbox shift lever (5) with two 3/8" x 1-1/4" bolts (6) and serrated flange nuts (3) (see [Figure 33 on page 46](#)).

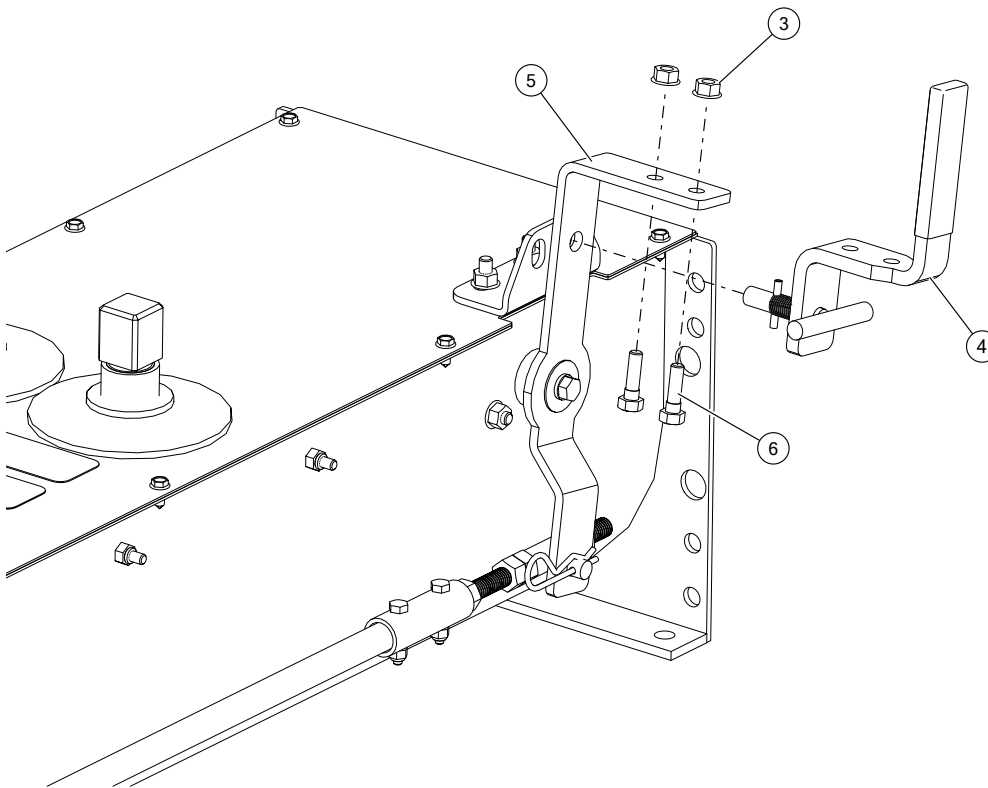
Figure 33. Assemble Gearbox Shift Handle

6.10. Floor Plank Completion and Sump Grates

1. Before installing the floor planks, check that all bolts and nuts on the underfloor auger are tight.
2. Install floor planks at a right angle across the top of the underfloor auger. While installing the floor planks, periodically check the function of the center sump gate, e-sump gate, intermediate sump gates, and lower gearbox engagement to ensure no control mechanisms interfere with the floor supports. If there is interference, slightly adjust the position of the floor support(s).
3. Cut the planks as necessary around the center sump, e-sump, and intermediate sumps.
4. Apply silicone sealant or neoprene rubber (not supplied) around the edge of each sump and screw the top surfaces of each sump grate to the floor planks using the #14 x 5/8" self-tapping screws provided (see [Figure 34](#)).

Figure 34. Install Sump Grates

Center Sump Grate

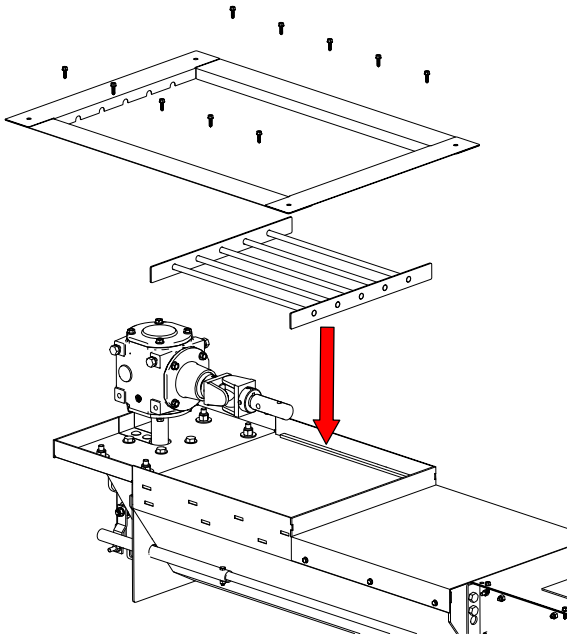

Intermediate Sump and E-Sump Grates

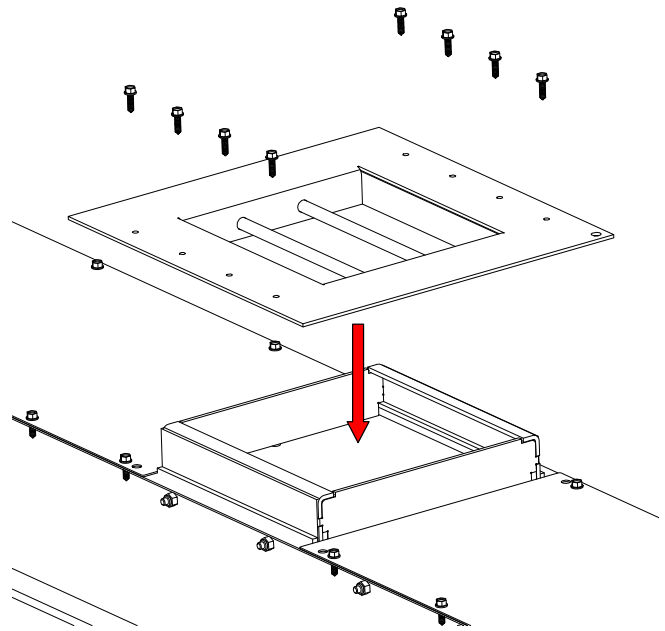

6.11. Assemble the U-Trough Extension (Optional)

Optional u-trough extensions are available in lengths of 3', 4.5', 6' and 9'.

1. Pull out the underfloor auger flighting (1) far enough to access the hole in the end of flighting. Fasten the flighting connecting shaft onto the underfloor flighting (1) with a $7/16'' \times 3''$ bolt (3) and nylon locknut (4) (see [Figure 35](#)).

Important

Make sure that the extension flighting is bolted onto the underfloor flighting so that the flightings are synchronized (the helical pattern continues across the bolted connection). If the connection is bolted a half-rotation out of position, it will not result in proper/optimum grain flow performance during operation.

Figure 35. Fasten Extension Flighting onto Underfloor Auger Flighting

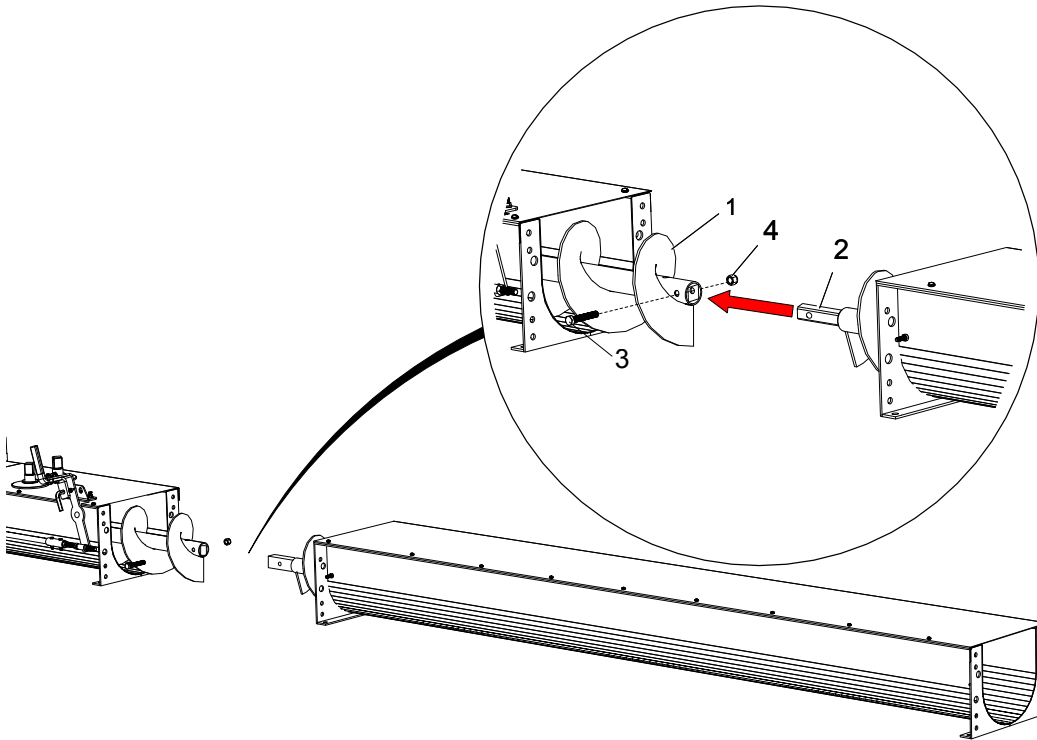

2. Mount the extension trough flange (5) onto the underfloor auger flange (6) with eight $1/2'' \times 1-1/4''$ bolts (7) and nylon locknuts (4) (see [Figure 36 on page 49](#)).

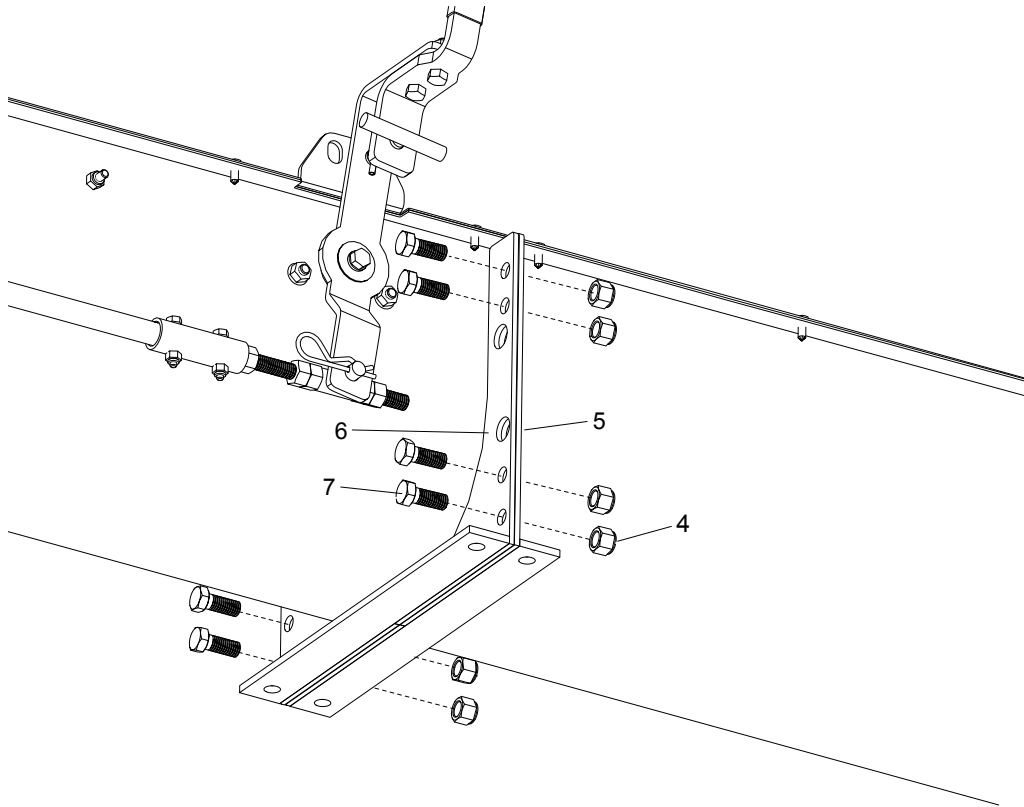
Figure 36. Mount Extension Trough onto Underfloor Flange

6.12. Assemble the Incline Powerhead (Optional)

➔ When equipped with an incline powerhead:

1. Pull out the underfloor flighting (1) far enough to access the hole in the end of flighting. Install the transition flighting (2) with a 7/16" x 3" bolt (3) and nylon locknut (4) (see [Figure 37](#)). Tighten securely.

Important

Make sure that the transition flighting is bolted onto the underfloor flighting so that the flightings are synchronized (the helical pattern continues across the bolted connection). If the connection is bolted a half-rotation out of position, it will not result in proper/optimum grain flow performance during operation.

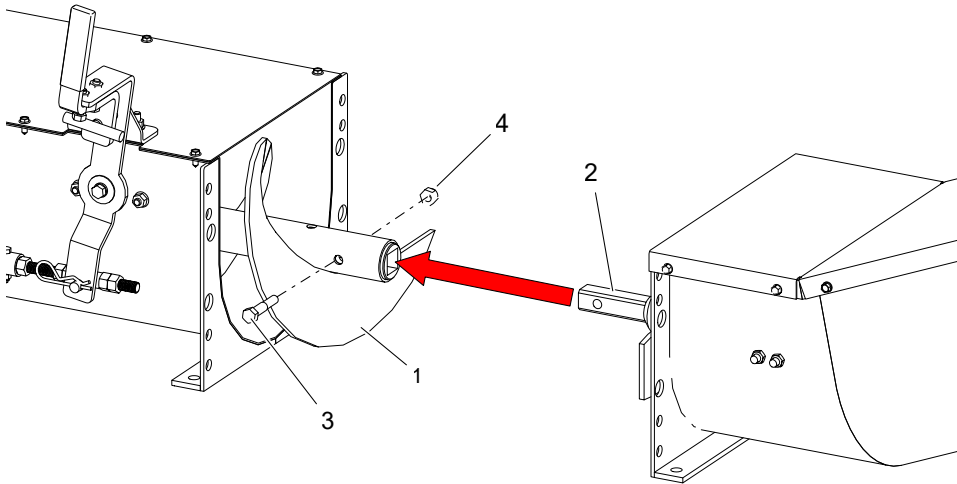
Figure 37. Install Transition Flighting

2. Push the underfloor flighting all the way back into the underfloor auger, ensuring that the opposite end of the flighting is securely fitted onto the flighting coupler connected to the lower gearbox shaft in the center sump.
3. Fasten the flange of the incline assembly (9) to the flange of the underfloor auger (10) using eight $\frac{1}{2}$ " x 1-1/4" bolts (11) and nylon locknuts (4) (see [Figure 38](#)).

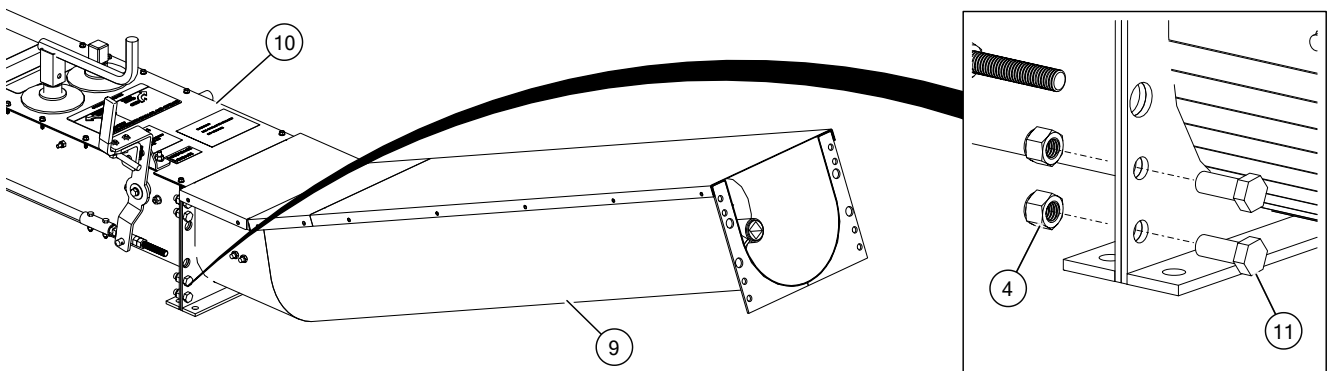
Figure 38. Fasten the Incline Assembly to the Underfloor Auger

4. Remove inspection cover and check and tighten four $\frac{3}{8}$ " set screws in the two threaded holes of the universal joint ends which are connected to the transition and incline flighting stub shafts (see [Figure 39 on page 51](#)).

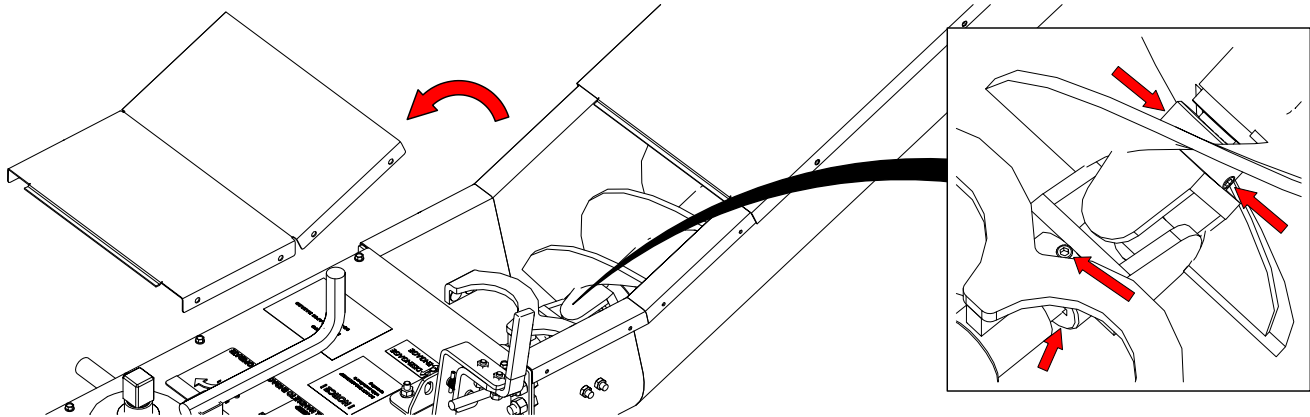
Figure 39. Secure Set Screws in Universal Joint

5. Re-attach the inspection cover to the incline assembly using the #14 x 5/8" self-tapping screws provided.
6. The incline powerhead should now appear as shown in [Figure 40](#). To complete the installation of the incline powerhead, follow the same steps as shown in [Section 6.13 – Assemble the Electric Powerhead \(if Equipped\)](#) on page 51, starting at Step 4.

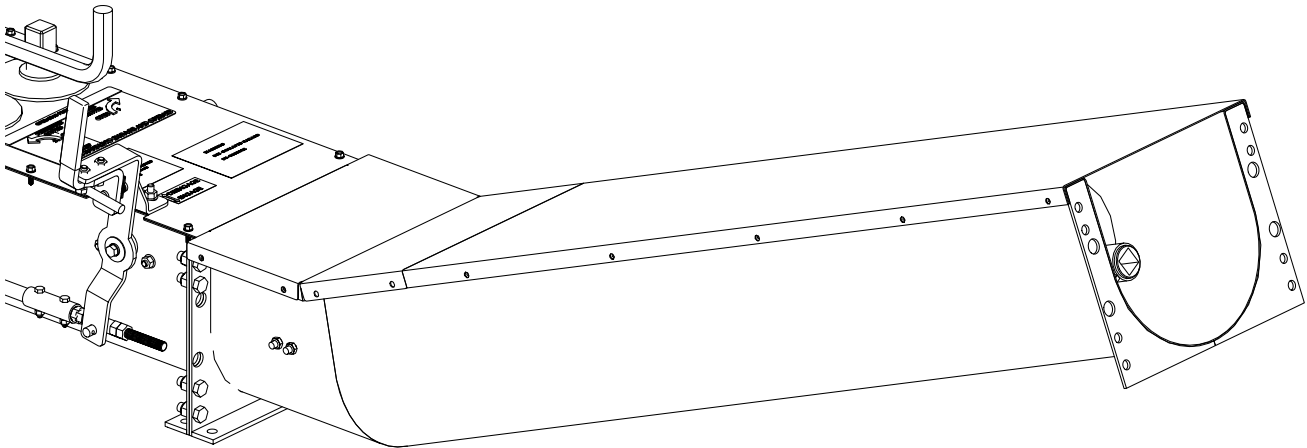
Figure 40. Assembled Incline

6.13. Assemble the Electric Powerhead (if Equipped)

- ➔ 1. **Horizontal Powerhead only:** Pull out the underfloor auger flighting (2) far enough to access the hole in the end of flighting.
2. Fasten the shaft (1) onto the flighting (2) with a 7/16" x 3" bolt (3) and nylon locknut (4) (see [Figure 41](#)).

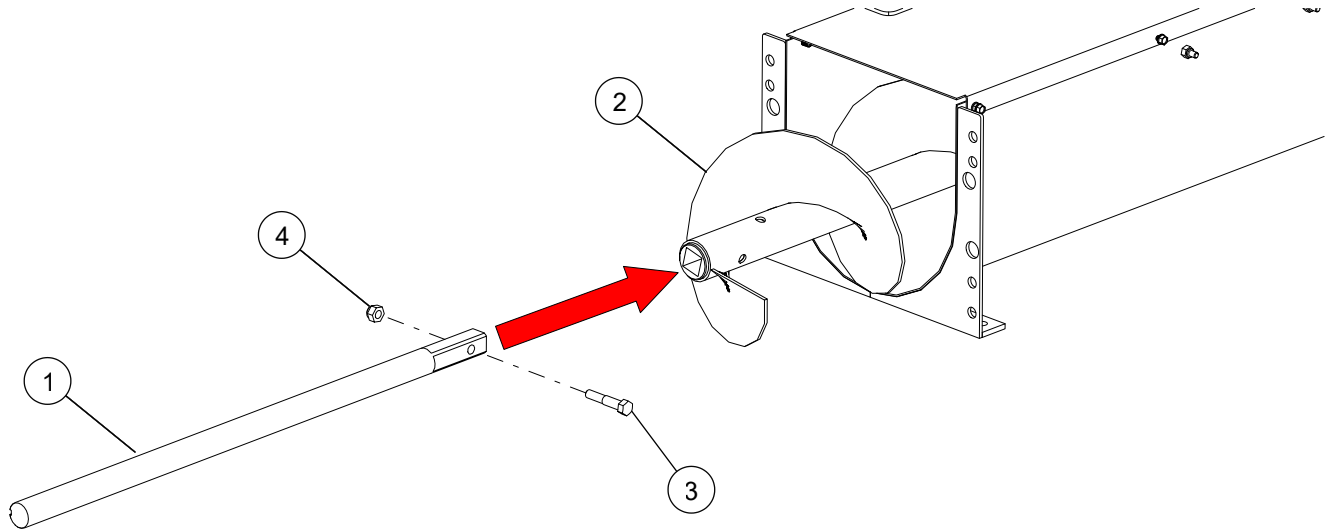
Figure 41. Fasten Shaft onto Underfloor Auger Flighting

- ➔ 3. **Horizontal Powerhead only:** Push the underfloor flighting all the way back into the underfloor auger, ensuring that the opposite end of the flighting is securely fitted onto the flighting coupler connected to the lower gearbox shaft in the center sump.
4. Mount the powerhead (5) onto the underfloor auger (6) with eight 1/2" x 1-1/4" bolts (7) and nylon locknuts (4) (see [Figure 42](#)). Ensure the powerhead shaft extends through the 4-bolt flange bearing and internal hanger bearing.

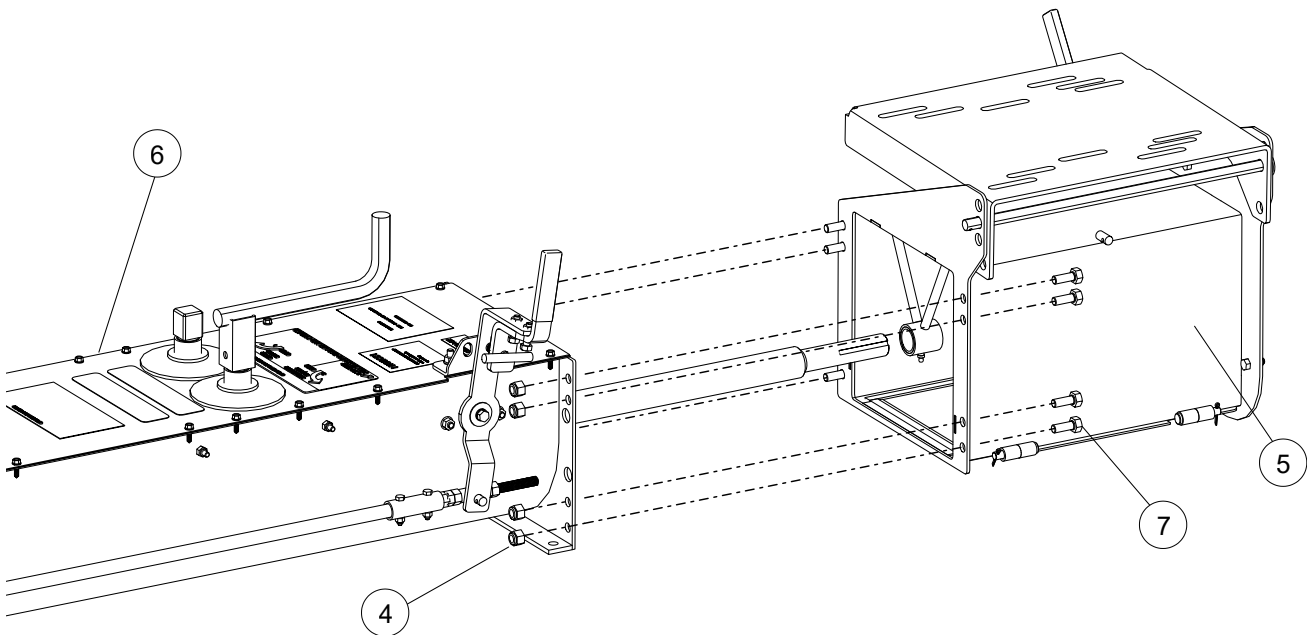
Figure 42. Mount Powerhead on the Underfloor Auger

5. Place the bearing lock collar (8) onto the flighting shaft. Use a hammer and punch to rotate the lock collar clockwise so that it seats onto the inner race of the bearing. Tighten the lock collar securely to the shaft with the set screw (9) (see [Figure 43](#)).

Figure 43. Mount the Bearing Lock Collar

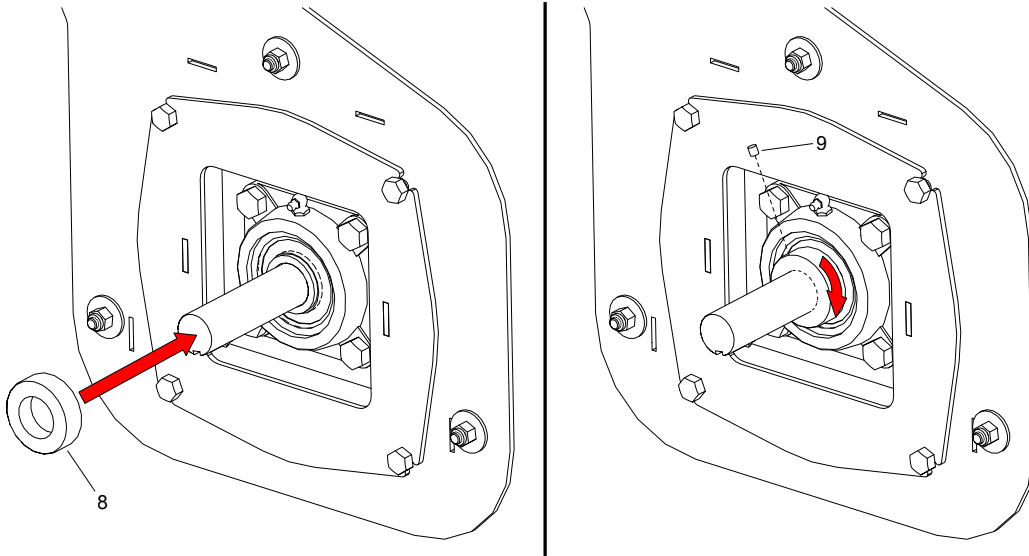

6.14. Electric Motor Installation / Alignment (if Equipped)

1. Place the electric motor (1) onto the motor mount (2) and secure with the motor mounting hardware, see [Figure 45 on page 55](#). Ensure that the motor shaft is parallel to and centered on the discharge end. Align the ends of the motor shaft and flighting shaft with a straight edge.
2. Have a qualified electrician perform the electrical connections and wiring to the electric motor. Ensure the requirements in [Section 2.5.1 – Electric Motor Safety on page 8](#) are met. See also [Table 8 on page 69](#).
3. Attach the pulley guard backplate (3) to the face of the powerhead using three 3/8" x 1" bolts (4), flat washers (5), and nylon locknuts (6). The backplate should sit flush with the head plate. Do not tighten bolts/nuts at this time; the backplate will need to be aligned later on.
- ➔ 4. **For two-piece drive pulleys only:** Install the drive pulley (7A) (see [Table 9 on page 69](#) for available pulley sizes, depending on desired flighting speed) using a 3/8" x 3" square key (8), hub (9), three bolts (11), three lock washers (10), and set screw (12). Align the drive pulley face flush with the end of the motor shaft and tighten. Do not tighten set screw until belts are aligned.
- ➔ 5. **For finished bore drive pulleys only:** Install the drive pulley (7B) (see [Table 9 on page 69](#) for available pulley sizes, depending on desired flighting speed) using a 3/8" x 3" square key (8) and set screw (12). Align the drive pulley face flush with the end of the motor shaft and tighten. Do not tighten set screw until belts are aligned.
6. Install the large unload pulley (13) onto the flighting shaft using a 1/4" x 2-1/2" square key (14) (see [Table 9 on page 69](#) for available pulley sizes, depending on desired flighting speed). DO NOT tighten set screws (not shown).
7. Place the belts (15) on the pulleys (7, 13).
8. Move the belt adjust handle (17) upward (engaged position). Ensure the 5/8" threaded rod (18) is positioned behind its slot in the motor mount to support the motor mount.
9. Align the two pulleys using a straight edge, ensuring that the large unload pulley is flush against the bearing lock collar.
10. To tension the belts, adjust the motor mount hinge pin (19) to the hole position that will keep the motor level and fully tension the belts. The hole selected will depend on the pulley diameters and the motor size (height between motor shaft and motor legs). Rotate the 5/8" threaded rod (18) in the clevis until the belts have approximately 1/4" – 1/2" (6 mm – 13 mm) deflection when a 5 lb (22 N) force is applied at the belt center. Tighten/lock the threaded rod in the clevis with the 5/8" hex nut (not shown).

Figure 44. Typical Drive Belt Tensioning

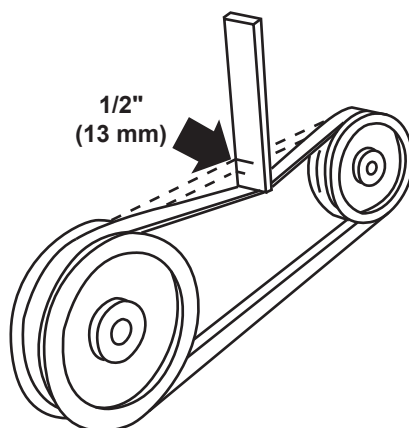

Note

The correct operating tension is the lowest tension at which the belts will not slip under peak load conditions.

11. Tighten all the set screws on the pulleys.

Note

Once all bolts and set screws are tightened, re-check alignment. Proper alignment will prolong belt life.

12. Once belt alignment is complete, move the backplate (3) to a position where the motor shaft will cause the least interference. Tighten the backplate bolts (4) securely.

13. Close and lock the plastic pulley guard (16) using the quick-clip.

Figure 45. Assembly of Pulleys and Belts

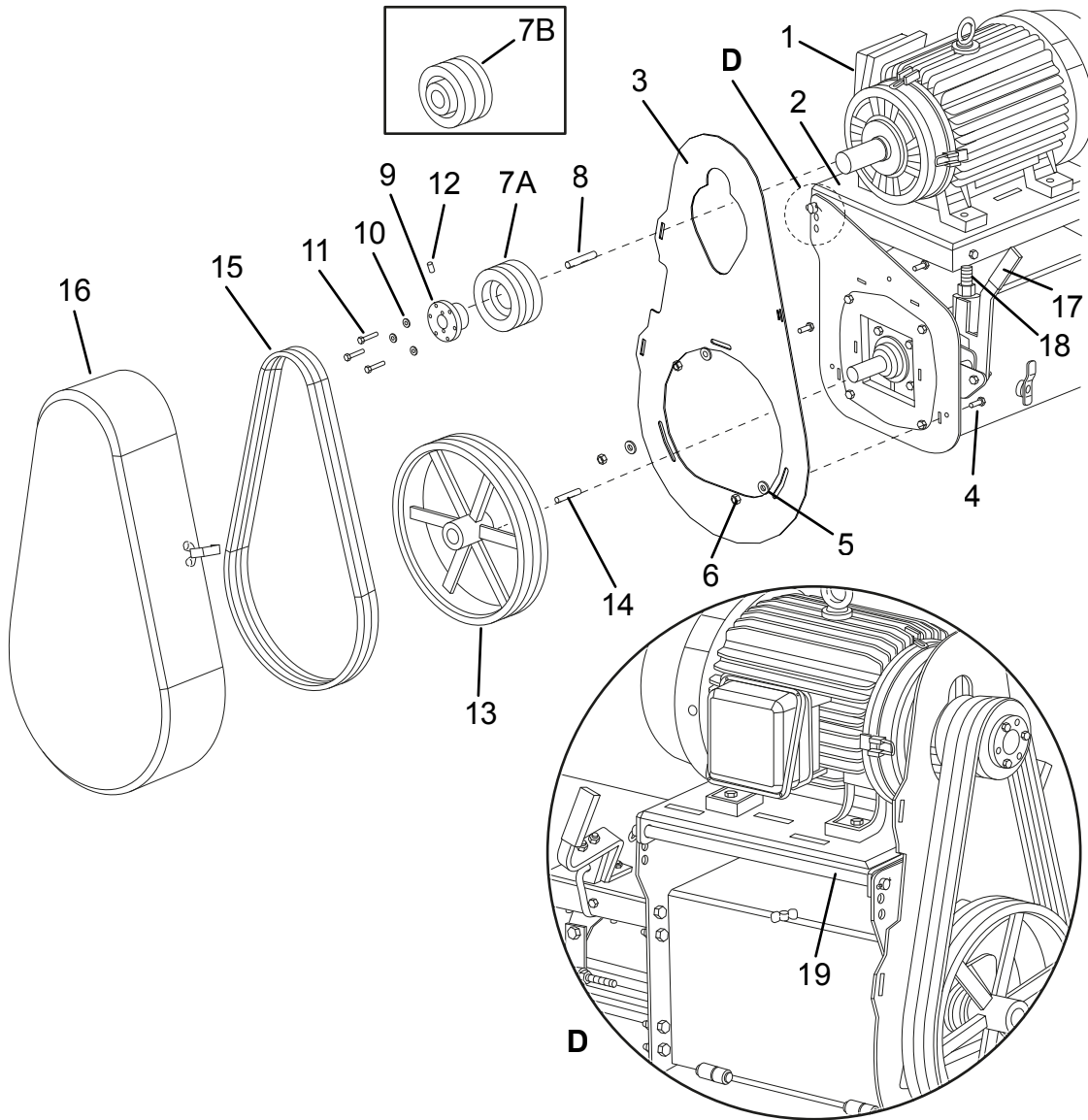

6.15. Assemble the Hydraulic Powerhead (if Equipped)

1. Install two 10 MORB x 1/2" FNPSM fittings (1) into the hydraulic motor (2).
2. Mount the hydraulic motor (2) to the cover plate (3) using two 1/2" x 1-3/4" bolts (4) and nylon locknuts (5).

Figure 46. Mount Hydraulic Motor to Cover Plate

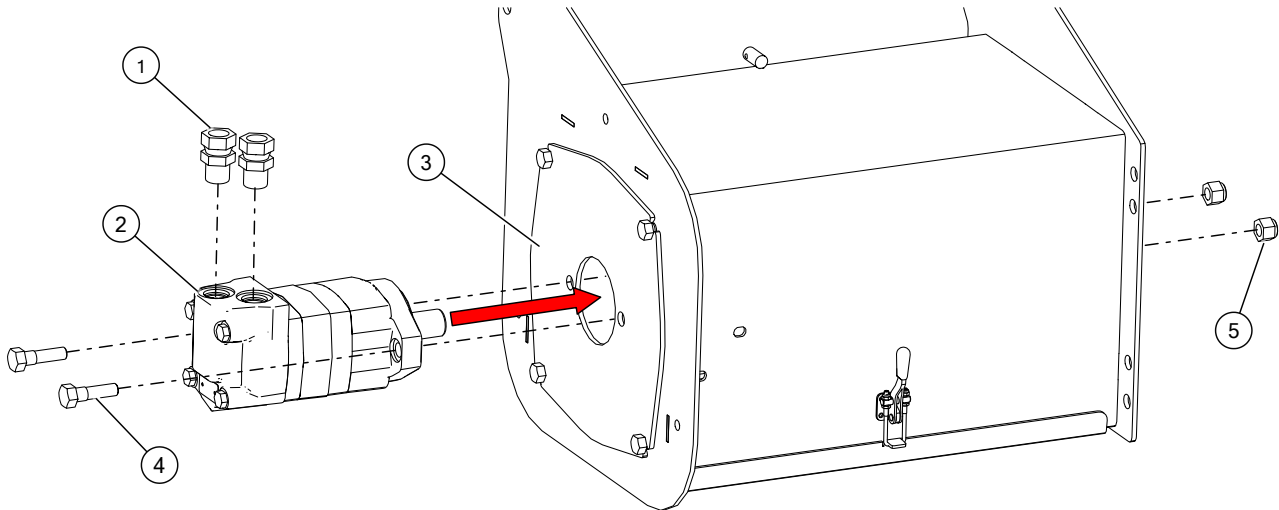

3. Attach the chain coupler to the hydraulic motor shaft using a woodruff key (6). Secure set screws.
4. Insert the powerhead shaft (8) through the hanger bearing and install to the chain coupler (7) using a 1/4" x 1-1/2" square key (10). Secure set screws (11).
5. Pull out the underfloor auger flighting (9) far enough to access the hole in the end of flighting.
6. **Horizontal Powerhead only:** Fasten the powerhead shaft (8) into the flighting with a 7/16" x 3" bolt (12) and nylon locknut (13). Tighten securely.

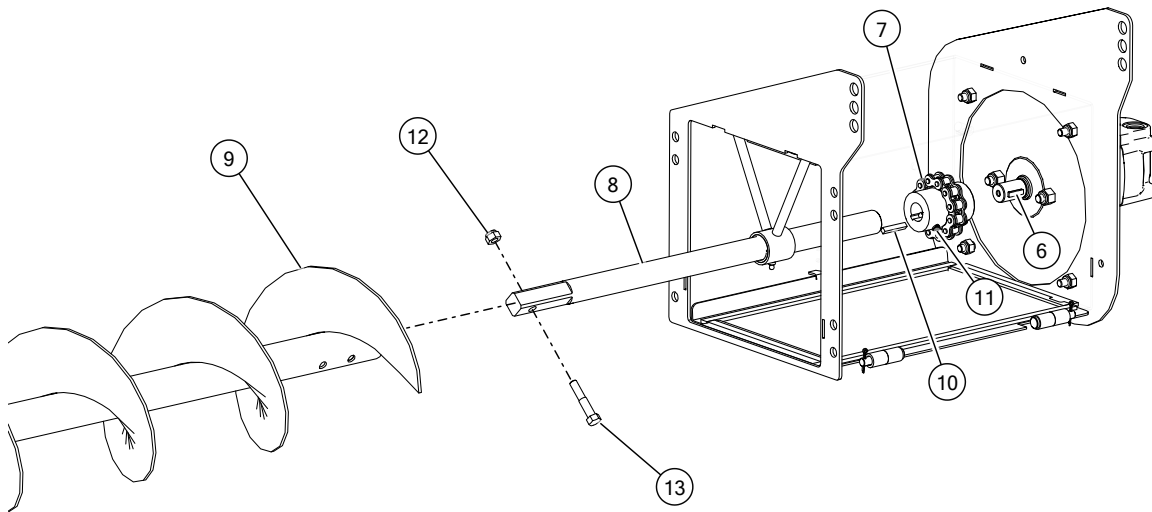
Figure 47. Attach Powerhead Shaft to Chain Coupler and Underfloor Flighting

7. **Horizontal Powerhead only:** Push the underfloor flighting all the way back into the underfloor auger, ensuring that the opposite end of the flighting is securely fitted onto the flighting coupler connected to the lower gearbox shaft in the center sump.
8. Mount the powerhead onto the underfloor auger with eight 1/2" x 1-1/4" bolts (14) and nylon locknuts (15).

Note

Hydraulic hoses that connect the hydraulic motor to the tractor are not supplied.

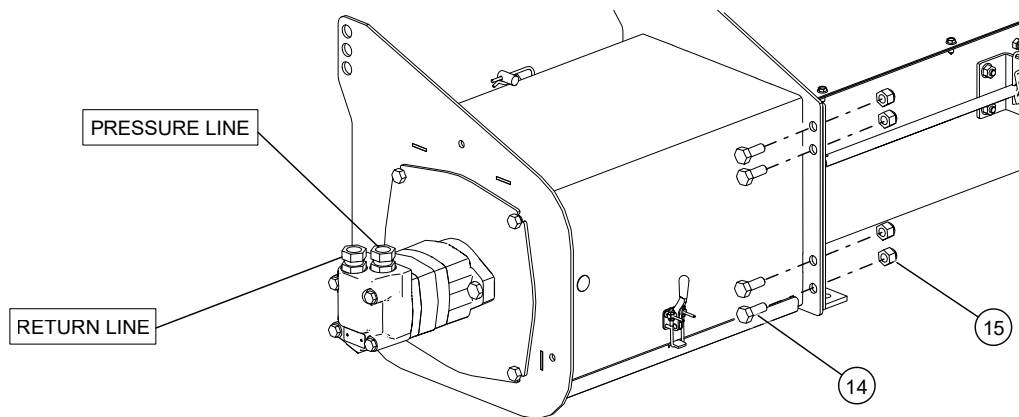
Figure 48. Mount Powerhead to Underfloor Auger

6.16. Install the Sweep End Wheel, Flighting, and Backboard

1. Install the end wheel sub-assembly (1) onto the end of the backboard with three 3/8" x 1" bolts (5), lock washers (6), flat washers (7), and serrated nuts (8) (see [Figure 49](#)). At the same time, secure the two 7/16" x 2-1/4" bolts (3) and nylon locknuts (4) to connect the sweep flighting (2) to the end wheel gearbox.

Figure 49. Install End Wheel Sub-Assembly

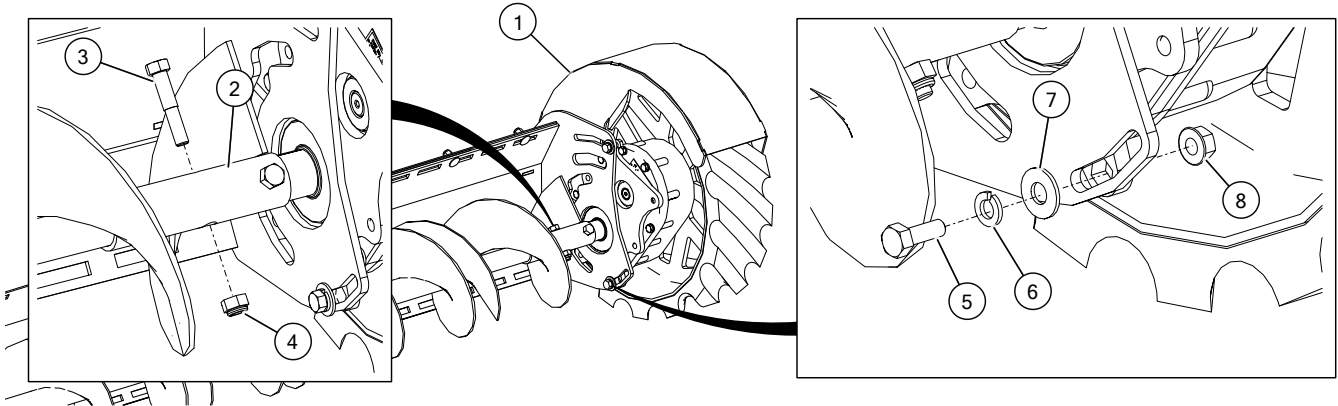

2. Attach the sweep flighting (2) to the yoke (9) in the universal joint (10) with two 7/16" x 2-1/4" bolts (3) and nylon locknuts (4) (see [Figure 50](#)).

Figure 50. Connect Sweep Flighting to Upper Gearbox

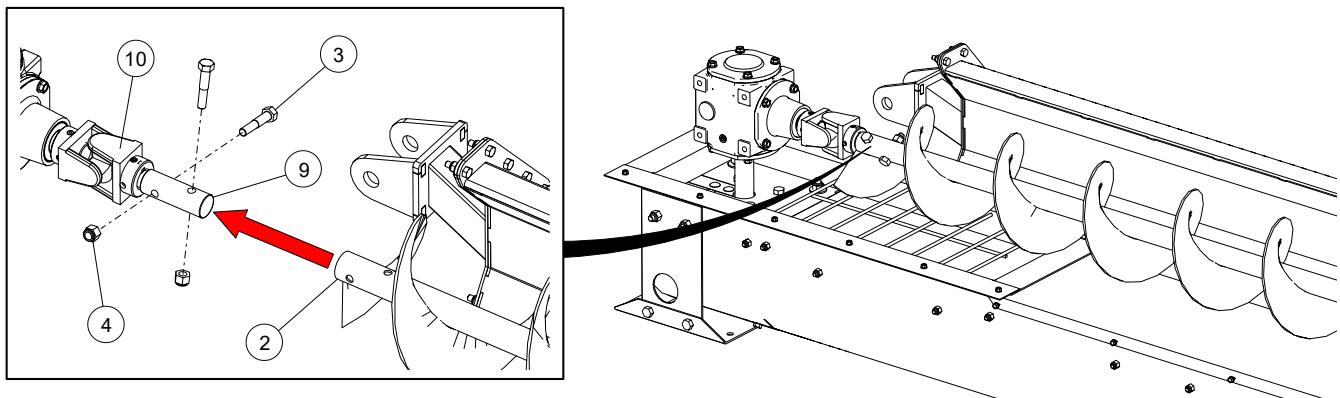

3. Fasten the backboard mounting bracket (14) to the upper gearbox (15) with four 1/2" x 1-1/2" bolts (16) and lock washers (17) (see [Figure 51 on page 59](#)). Do not fully tighten bolts at this time.

Note

Position A is the standard setting for all flighting. Positions B and C are secondary to adjust so the flighting does not hit the floor.

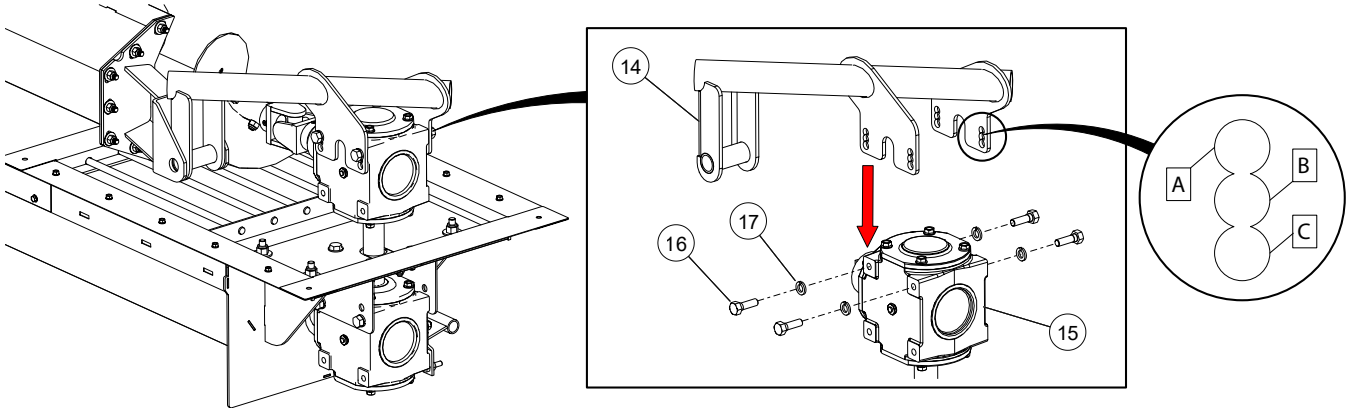
Figure 51. Attach Backboard Mounting Bracket on Upper Gearbox

- Secure the backboard pivot pin (18) between the backboard mounting bracket (14) and backboard connector (19) with two 1/4" x 1-1/2" bolts (20) and nylon locknuts (21) (see [Figure 52](#)).

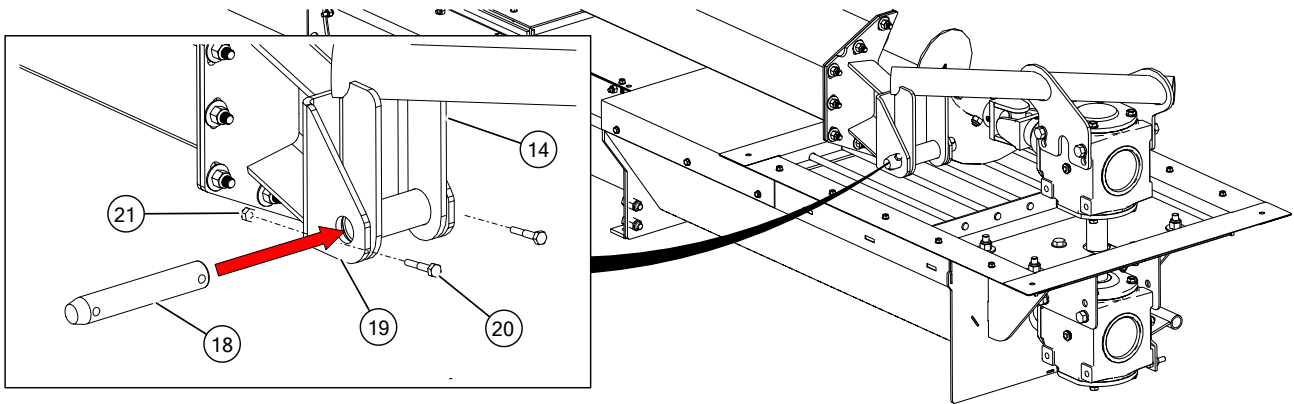
Figure 52. Connect Backboard Mounting Bracket to Backboard Connector

- Fully tighten the four bolts (16) that fasten the backboard mounting bracket to the upper gearbox (see [Figure 51](#)).

6.17. Set Backboard Clearance

- Slightly loosen the three 3/8" bolts on the backboard pivot mount plate with slotted holes nearer the sweep drive wheel (see [Figure 53 on page 60](#)).

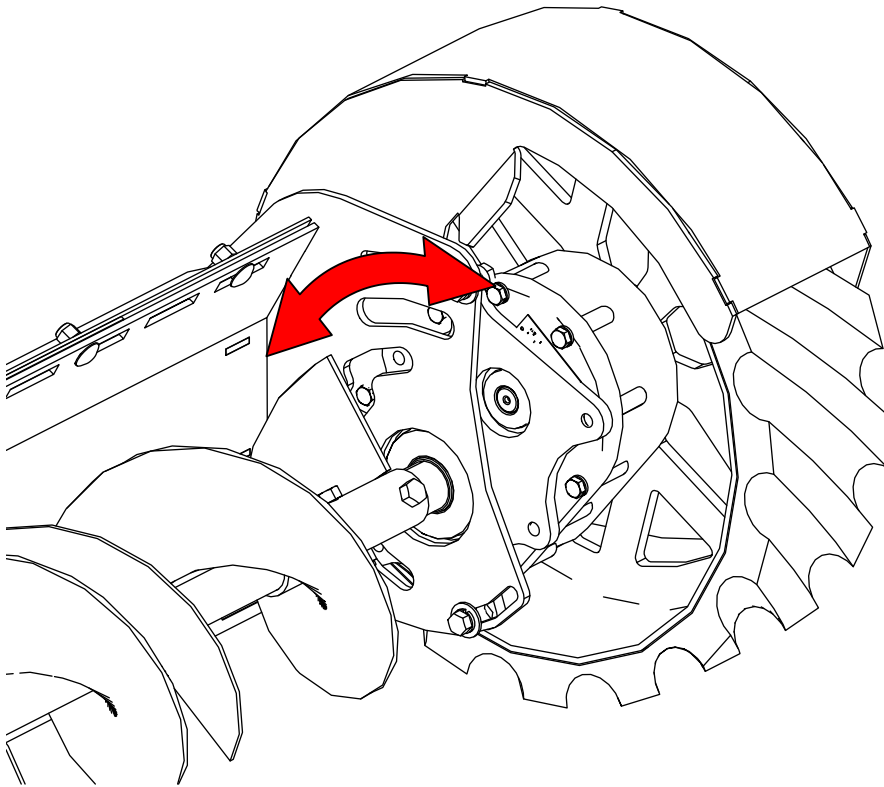
Figure 53. Adjusting Sweep Backboard Height at Sweep Drive Wheel

2. Slightly loosen the eight 3/8" bolts on the backboard pivot mount plate with slotted holes near the center sump (see [Figure 54](#)).

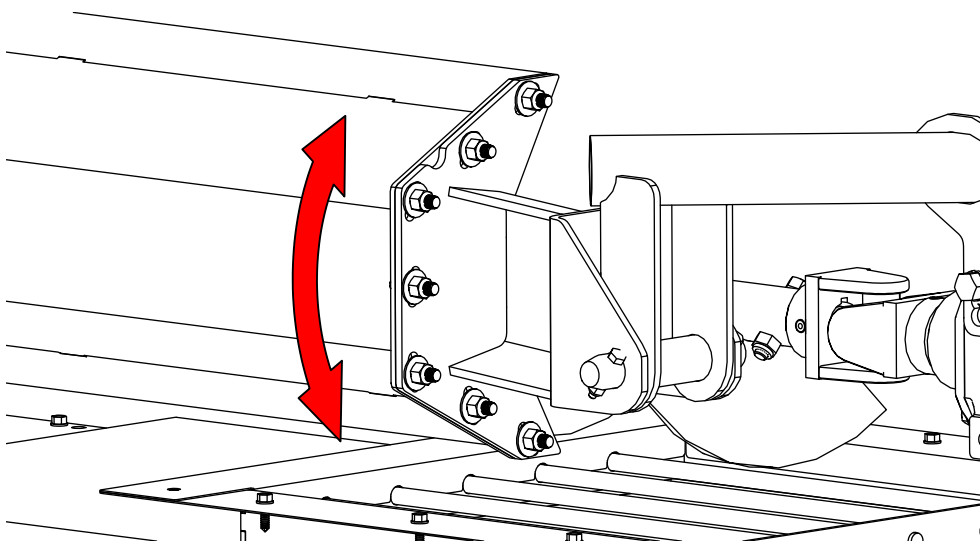
Figure 54. Adjusting Sweep Backboard Height near Center Sump

3. Rotate the backboard so that its lower scraper is resting on 1/4" wood blocks which are placed underneath the backboard scraper every 3' (0.9 m). This sets the required clearance between the backboard scraper and the bin floor.
4. Retighten all the bolts which were loosened.

6.18. Install the Sweep Stop

- Using the sweep stop as a template, mark and drill the four holes in the bin wall (1). The sweep stop should be positioned:
 - Far enough from the bin door so that it won't contact when opened.
 - High enough that the sweep end wheel fender will clear the sweep stop in its raised position. The bottom slot should be approximately 12"-14" (305mm — 356mm) from the top of the bin floor.
- Mount the sweep stop (3) to the inside of the bin using four 1/4" x 1" bolts (4), flat washers (6), sealing washers (5) and nylon locknuts (7).

Figure 55. Install the Sweep Stop

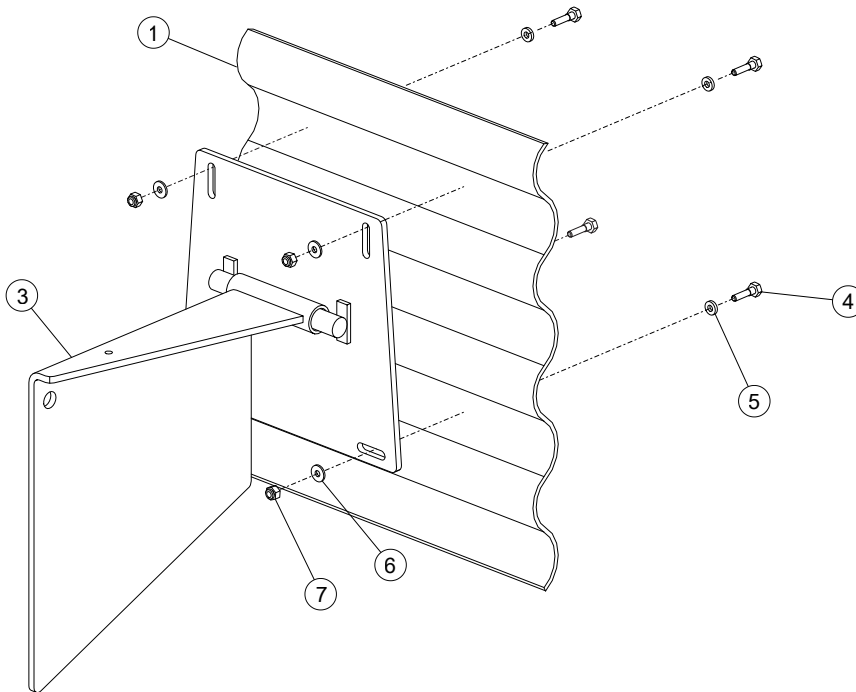

- Measure 3-1/8" (79mm) from the top of the sweep stop to mark and drill a 9/16" hole. Install the hydraulic fitting and 9/16" jam nut.
- Run one end of the cable through the top hole on the sweep stop, create a loop and secure with a cable clamp.
- Route the other end of the cable through the hydraulic fitting in the bin wall to the outside of the bin.
- Route the end of the cable through the pipe handle, create a loop, and secure with a cable clamp.
- Test the sweep stop (see [Section 6.19 – Testing on page 62](#)) and make any adjustments if necessary.

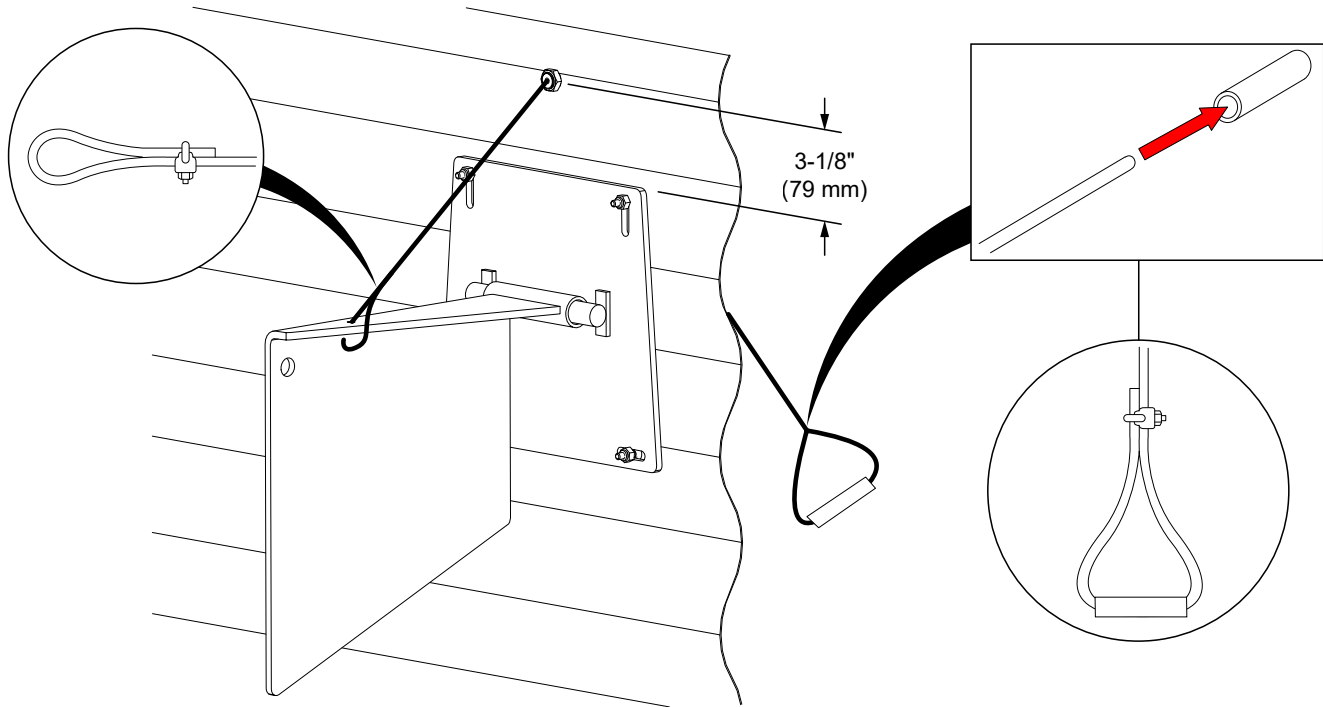
Figure 56. Route the Cable

6.19. Testing

1. Ensure that the power to the bin unload system is shut down and locked out.
2. Ensure that there are no obstructions in the sumps, sweep flighting, or sweep path along the bin floor.
3. Move the gearbox shift handle to the engaged position (B) (see [Figure 57 on page 63](#)).

NOTICE

Use the locking pin to lock the gearbox shift handle into the engaged or disengaged position at all times. Failure to do so will result in damage to gearbox.

Figure 57. Lower Gearbox Engagement & Disengagement for Sweep

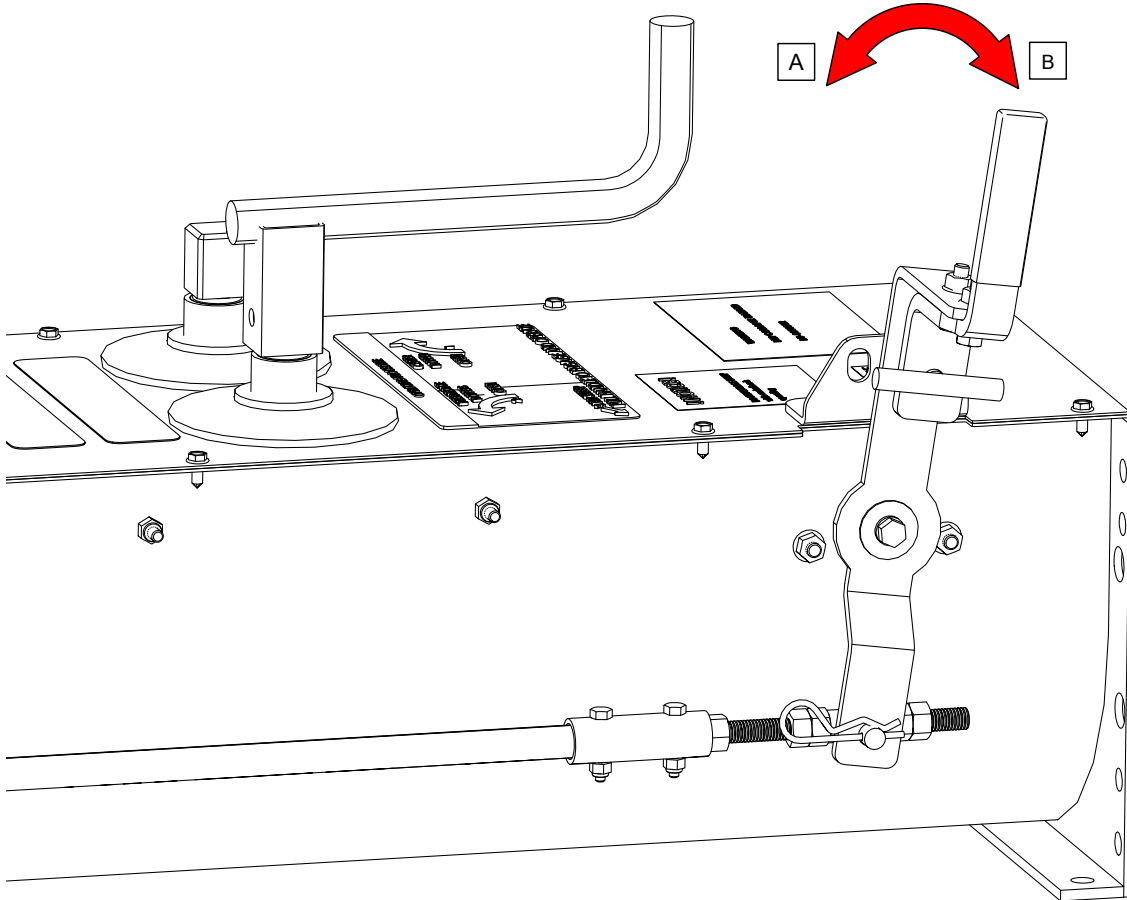

4. Unlock the power to the bin unload system.



DANGER During testing, KEEP AWAY from rotating flighting. Do not perform adjustments on the equipment while it is being tested.

5. Turn on the electric powerhead to bin unload system so that underfloor auger flighting and sweep flighting are both rotating.
6. Move the gearbox shift handle to the disengaged position (A) and ensure the lower gearbox comes fully out of gear with no grinding (see [Figure 57](#)). Then shut down the bin unload system.
 - If grinding occurred when disengaging the gearbox shift handle: Lock out whole bin unload system. Adjust the gearbox shift adjust tube as noted in the Maintenance chapter of the Operator's Manual.
 - If grinding did not occur: With the unload system shut down, re-engage the gearbox. Restart the electric powerhead so that underfloor auger flighting and sweep flighting are both rotating.

NOTICE

To prevent damage to the unload system, DO NOT engage bin sweep while underfloor auger is operating.

7. Perform a test-run of the bin sweep (one full revolution around bin). During testing check the general function of the system and monitor the following:
 - a. Ensure that the bushings (between sweep sections) are not interfering with the sweep flighting.
 - b. Ensure sweep backboard does not catch on high spots on the aeration floor. If necessary, consult bin or aeration floor assembly manual to level.
 - c. Observe the end of the bin sweep around the bin and note the position in its revolution which has the minimum clearance to the bin wall. This minimum clearance will later be used to adjust the sweep extender.
 - d. Allow the end wheel to contact the sweep stop to ensure it prevents the sweep from advancing.
 - e. Using the sweep stop cable outside of the bin, lift up the sweep stop to ensure the end wheel will clear it and perform a second pass.
8. After the bin sweep has completed its test-run, ensure the sweep is in its “start/park position” (directly over the intermediate sumps), and then shut down and lock out bin unload system.

NOTICE

Failure to park the bin sweep over the intermediate sumps could result in damage to the bin sweep when it is next operated.

9. Close all sump gates.

6.20. Adjust the Bin Sweep Extension

1. Remove the five 3/8" x 1" carriage bolts (1) and locknuts (2) on the top and bottom of the backboard extension (see [Figure 58](#)).
2. Move the extension outward to the same length as the minimum clearance between the end of the sweep and the bin wall (and attached parts), as observed during the full test-run revolution. Pull and twist the sweep flighting to extend it.
3. Re-fasten the bolts on the backboard extension.

Figure 58. Adjust Bin Sweep Extension

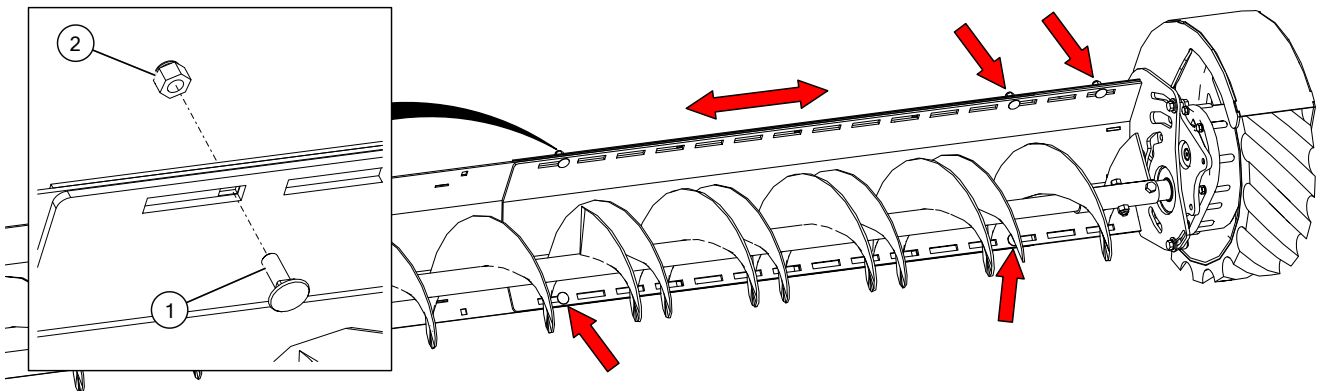

6.21. Attach the Westeel Brand Logo Decal

1. Apply the brand logo decal to the pulley guard (see [Figure 59](#)).

Important

Do not cover any existing safety or instruction decals with the brand logo decal.

2. Refer to [Section 2.8.1 – Decal Installation/Replacement on page 10](#) for specific instructions on applying decals.

Figure 59. Placement for the Brand Logo Decal (Electric Powerhead)

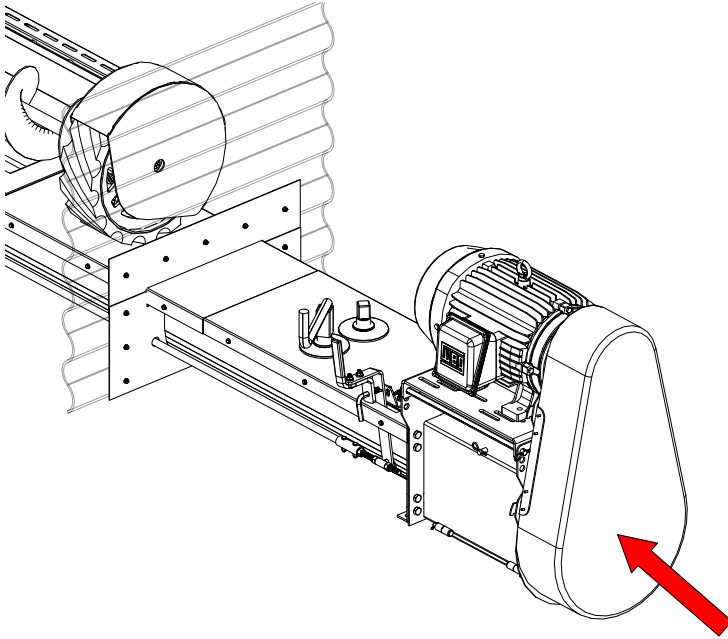
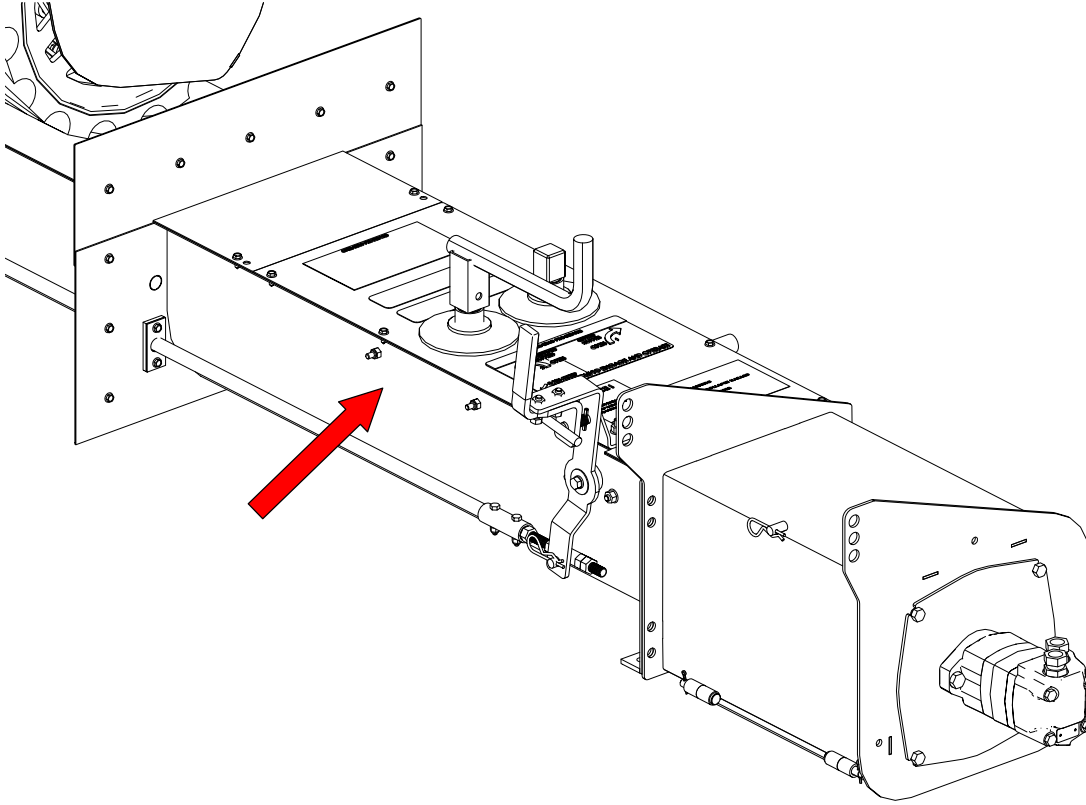
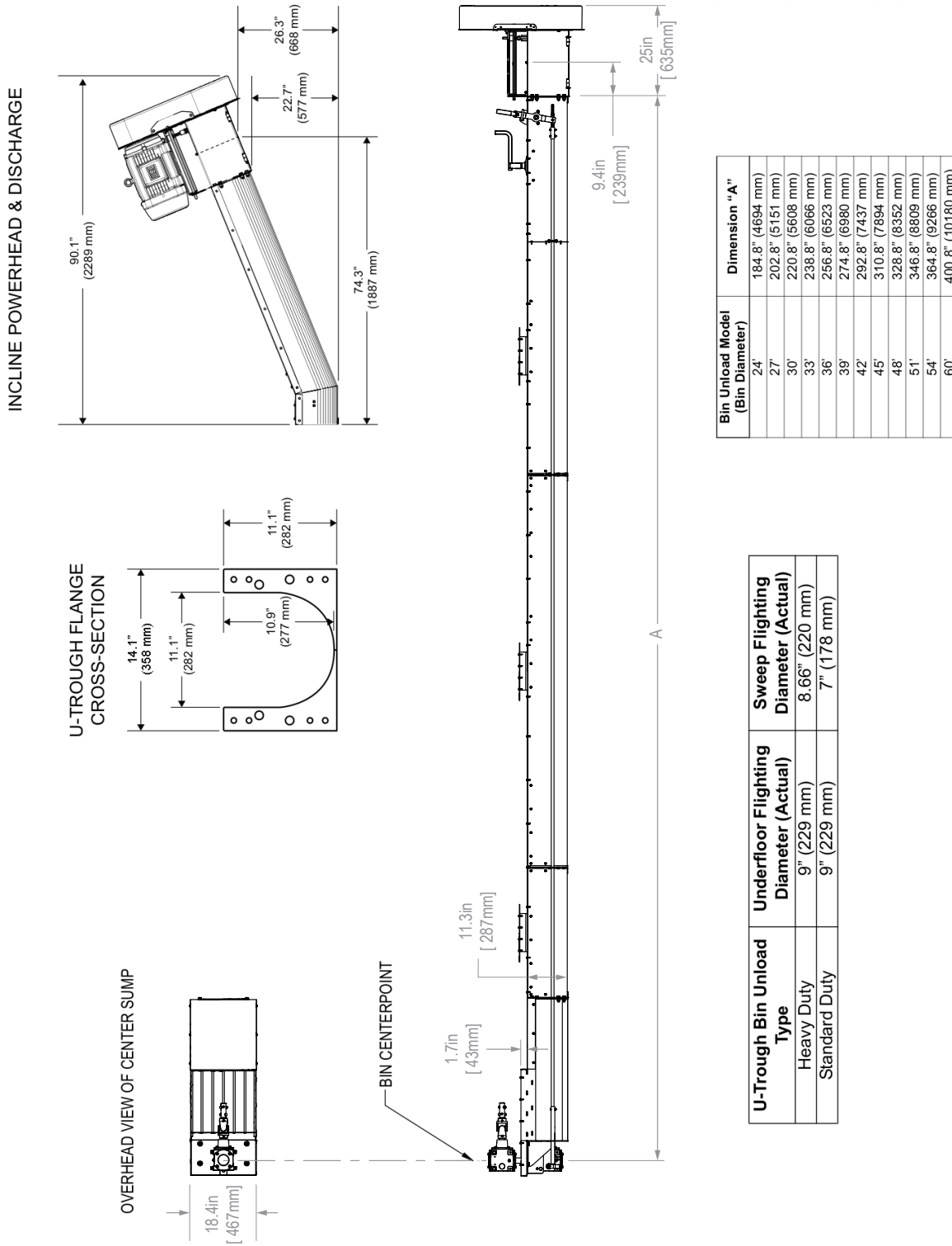

Figure 60. Placement for the Brand Logo Decal (Hydraulic Powerhead)



7. Specifications

7.1. Mechanical



7.2. Bin Unload System Sizes

Bin Unload System Models (Bin Diameters)

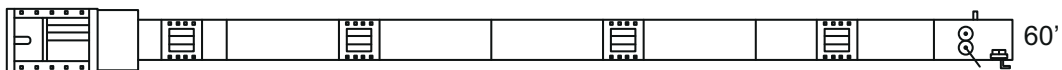
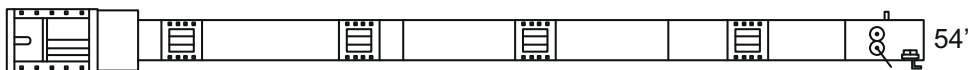
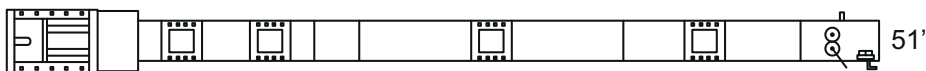
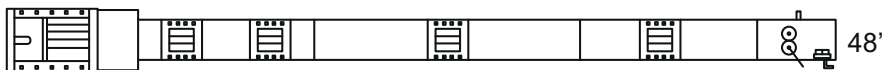
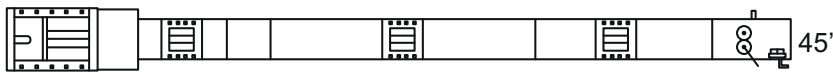
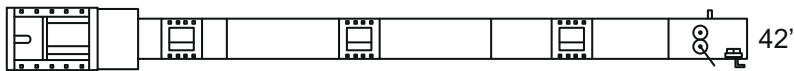
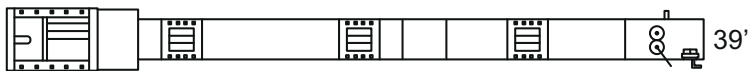
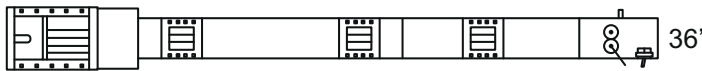
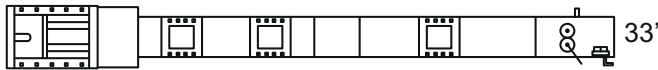
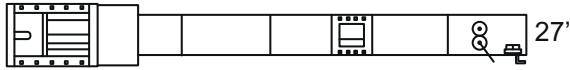

7.3. Power Requirements

Table 8. Electric Motor Requirements

Bin Unload Model (Bin Diameter)	System Horsepower (hp) Requirements with Sweep	
	Standard Duty (7" Sweep Flighting)	Heavy Duty (8.66" Sweep Flighting)
24'	7.5	10
27' / 30' / 33'	10	10
36' / 39'	10	15
42' / 45'	15	15
48' / 51'	15	20
54' / 60'	20	20

Table 9. Recommended Pulley Size Combinations

Unload Pulley	Drive Motor Pulley	Pulley Type	Belt Size	Flighting Speed (rpm)
15"	4-3/4"	Triple Groove	B65	554
16"	4"	Triple Groove	B65	438

Flighting Speed is calculated using a 1750 rpm electric motor. To determine flighting speed (rpm), divide the motor speed (rpm) by the outside diameter of the large unload pulley, then multiply by the outside diameter of the small motor pulley. Example: $1750 \text{ rpm} / 15" \times 4\text{-}3/4" = 554 \text{ rpm}$.

If a slower flighting speed is desired, install a smaller motor pulley.

For 51', 54', and 60' bin unload models used in dense crops (such as wheat or canola), a flighting speed of 438 rpm is recommended.

Table 10. Hydraulic Requirements

Bin Unload Model (Bin Diameter)	Motor Displacement	Tractor Flow & Pressure Requirements	Hose & Ends
24' - 39'	6.2 cu in/rev	12 GPM @ 1700 PSI	1/2" MPT end x 1/2" Hose
42' - 60'	9.6 cu in/rev	20 GPM @ 2200 PSI	1/2" MPT end x 1/2" Hose

8. Bin Unload Limited Warranty

Ag Growth International (“AGI”) warrants all new equipment manufactured by it or one of its divisions, and purchased from an authorized dealer or distributor, to be free from defects in materials or workmanship for a period of two (2) years from the date of original purchase or initial installation (“Warranty Period”).

AGI’s obligation under this warranty is limited to repairing, replacing, or refunding defective part(s) during the Warranty Period. Labor costs associated with the repair of the warranted equipment are not covered by AGI. Any defects must be reported to AGI before the expiry of the Warranty Period and defective parts identified during the Warranty Period must be returned to the factory, or an authorized AGI dealer or distributor, with transportation charges prepaid.

Bin Unload systems are designed for use with free flowing, properly conditioned grains and are not warranted for use with other substances. Any other use is considered misuse. Malfunctions or failure resulting from misuse, abuse, negligence, alteration, accident, or lack of proper maintenance shall not be considered defects under this warranty. This warranty shall be void if components of the system are not original equipment supplied by AGI, or if the equipment has not been assembled, installed, operated, and maintained in accordance with instructions published by AGI.

The total liability of AGI on any claim, whether in contract, tort or otherwise, arising out of, connected with, or resulting from the manufacture, sale, delivery, repair, replacement or use of the equipment or any part thereof, shall not exceed the price paid for the equipment. AGI shall not be liable for any consequential or special damage which any purchaser may suffer or claim to suffer as a result of any defect in the equipment. Consequential or special damages as used herein include, but are not limited to, lost or damaged products or goods, costs of transportation, lost sales, lost orders, lost income, increased overhead, labor and incidental costs and operational inefficiencies.

The warranty provisions herein constitute the full extent of the warranties supplied by AGI for the equipment. Without limiting the generality of the foregoing and to the extent permitted by law, AGI EXPRESSLY DISCLAIMS AND EXCLUDES ALL WARRANTIES AND CONDITIONS OF MERCHANTABILITY & FITNESS FOR PURPOSE OR PERFORMANCE, WHETHER EXPRESS OR IMPLIED, STATUTORY OR OTHERWISE.

Notwithstanding anything contained herein to the contrary, the foregoing sets out the purchaser’s sole and exclusive remedies for breach of warranty by AGI in respect of the equipment.

Dealers are not authorized to make any modifications on behalf of AGI, to any of the terms, conditions or limitations of this warranty.

AGI reserves the right to change models and specifications at any time without notice or obligation to improve previous models.



450 Desautels Street
P.O. Box 792
Winnipeg, Manitoba, R3C 2N5 Canada
Phone: 1-888-937-8335

Website: www.aggrowth.com
Email: customerservice.winnipeg@westeel.com
©Ag Growth International Inc. 2021
Printed in Canada

If you have any comments or questions on this manual, or find an error, email us at comments@aggrowth.com.
Please include the part number listed on the cover page in your message.