



# Swing-Away Conveyor

## Portable Grain Belt Conveyor Operator's Manual

**This manual applies to:**

**Batco, Westfield, Hutchinson, GrainMaxx**

**1500 SA Series**

**2000 SA Series**

**2400 SA Series**



Read this manual before using product. Failure to follow instructions and safety precautions can result in serious injury, death, or property damage. Keep manual for future reference.

Part Number: 8210-00011 R1

Revised: March 2021

Original Instructions



# CONTENTS

- 1. Introduction ..... 5**
  - 1.1 Serial Number Location ..... 5
  - 1.2 Intended Use ..... 5
    - 1.2.1 Misuse ..... 6
- 2. Safety..... 7**
  - 2.1 Safety Alert Symbol and Signal Words..... 7
  - 2.2 Follow Safety Instructions ..... 7
  - 2.3 Overhead Power Lines ..... 7
  - 2.4 Moving Conveyor Belt Safety..... 8
  - 2.5 Upending ..... 8
  - 2.6 Rotating Parts Safety..... 8
  - 2.7 Work Area Safety ..... 8
  - 2.8 Guards Safety ..... 9
  - 2.9 Raising and Lowering the Conveyor..... 10
  - 2.10 Hydraulic Winch Safety ..... 10
  - 2.11 Positioning the Conveyor ..... 10
  - 2.12 Towing the Conveyor ..... 10
  - 2.13 Drives and Lockout Safety..... 11
    - 2.13.1 PTO Driveline Safety..... 11
    - 2.13.2 Hydraulic Power Safety ..... 12
  - 2.14 Tire Safety..... 13
  - 2.15 Personal Protective Equipment..... 13
  - 2.16 Safety Equipment ..... 14
  - 2.17 Safety Decals ..... 14
    - 2.17.1 Decal Installation/Replacement..... 14
    - 2.17.2 Safety Decal Locations and Details ..... 15
- 3. Features..... 26**
  - 3.1 Model Number ..... 28
- 4. Transport..... 29**
  - 4.1 Transport Safety ..... 29
  - 4.2 Transport Preparation..... 29
  - 4.3 Connecting the Conveyor to the Towing Vehicle ..... 30
- 5. Placement ..... 31**
  - 5.1 Placement Safety..... 31
  - 5.2 Positioning the Conveyor ..... 31
    - 5.2.1 Raising and Lowering ..... 33
  - 5.3 Extendable Axle Positioning..... 34
  - 5.4 Raising and Lowering ..... 35
  - 5.5 Hitch Adjustment..... 36
  - 5.6 Extended Swing Arm ..... 37
  - 5.7 Raising and Lowering the Intake Hopper..... 38
  - 5.8 Hydraulic Power Swing Operation ..... 39
  - 5.9 Electric Power Swing Operation..... 40
  - 5.10 Collapsible Hopper Cloth Control..... 43
  - 5.11 Conveyor Operating Angles ..... 43

**6. Operation ..... 45**

    6.1 Operation Safety ..... 45

    6.2 Start-up and Break-in ..... 45

    6.3 Operation - Swing Away Transfer Hydraulic Motor Drive ..... 46

    6.4 Operation - PTO Drive ..... 47

    6.5 Loading Area ..... 47

    6.6 Conveyor Belt Speed ..... 47

    6.7 Emergency Shutdown ..... 48

    6.8 Restarting with a Full Tube ..... 48

    6.9 Shutdown ..... 48

    6.10 Clean Out ..... 49

    6.11 Conveying Fertilizer ..... 49

    6.12 Storage ..... 51

**7. Maintenance ..... 52**

    7.1 Maintenance Safety ..... 52

    7.2 Maintenance Schedule ..... 52

    7.3 Visually Inspect the Equipment ..... 53

    7.4 Lubricate the Equipment ..... 54

        7.4.1 PTO Driveline ..... 54

    7.5 Oil the Chain Coupler ..... 54

    7.6 Check the Gearbox Oil ..... 55

    7.7 Change the Gearbox Oil ..... 55

    7.8 Inspect Hydraulic Hoses and Fittings ..... 56

    7.9 Inspect the Hopper Flashing ..... 56

    7.10 Check the Roller Bearings ..... 56

    7.11 Check the Rollers ..... 56

    7.12 Tension the Conveyor Belt ..... 56

        7.12.1 S-Drive Pinch Roller ..... 57

    7.13 Align the Conveyor Belt ..... 58

        7.13.1 Adjust the Rollers ..... 59

        7.13.2 Adjust the Belt Return Wear Blocks ..... 60

    7.14 Inspect Belt Lacing ..... 60

    7.15 Replace the Belt Lacing ..... 61

    7.16 Replace the Conveyor Belt ..... 61

    7.17 Clean and Wash the Equipment ..... 62

    7.18 Repack the Wheel Bearings with Grease ..... 63

    7.19 Check/Adjust the Truss Cables ..... 63

    7.20 Inspect and Service the Hydraulic Winch and Lift Cable ..... 65

**8. Troubleshooting ..... 66**

**9. Specifications ..... 69**

**10. Appendix ..... 71**

    10.1 Power Swing Remote Transmitter Instructions ..... 71

    10.2 Programming Receivers ..... 72

**11. Limited Warranty ..... 74**

# 1. Introduction

Thank you for your purchase. Follow the instructions in this manual for safe use of this conveyor. Following proper operation and maintenance will help to keep the conveyor running in optimal condition.

Keep this manual handy for frequent reference and to review with new personnel. A sign-off form is provided on the inside front cover for your convenience. If any information in this manual is not understood or if you need additional information, please contact AGI or your representative for assistance.

This manual should be regarded as part of the equipment.

## 1.1. Serial Number Location

The serial number location for your conveyor is shown in the figure below. Have the serial number ready when ordering parts or requesting service or other information. Record information in the table below for easy reference.

<b>Model Number</b>	
<b>Serial Number</b>	
<b>Date Received</b>	

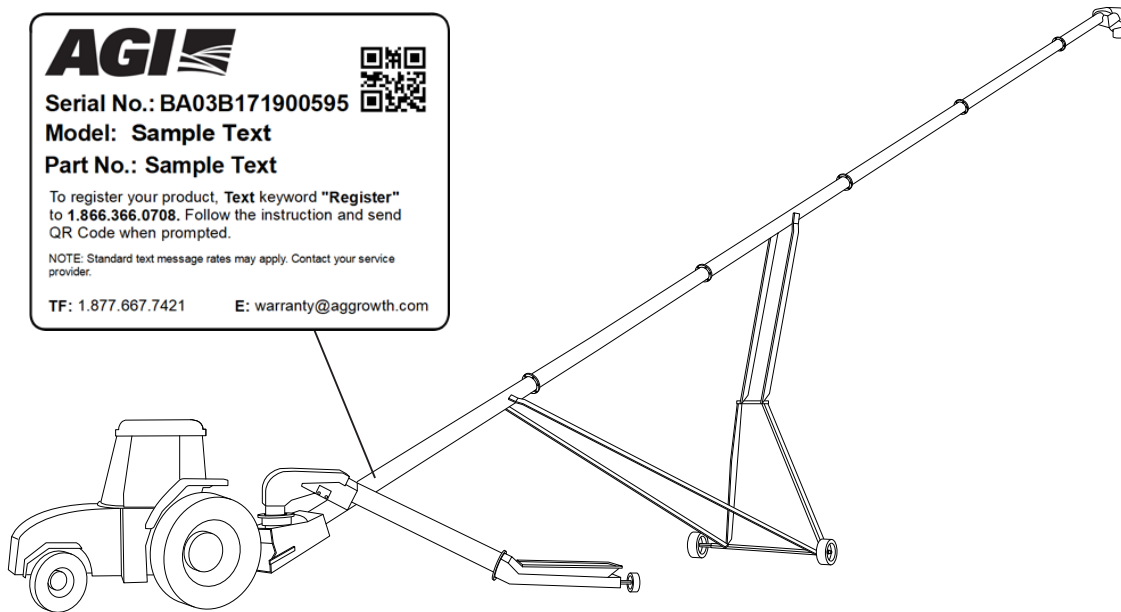

## 1.2. Intended Use

The conveyor is intended for use as listed below and described throughout this manual. Use in any other way is considered contrary to the intended use and is not covered by the warranty.

**Intended use for the conveyor:**

- Handling grain, pulse crops, treated seeds, or other similar materials.
- Handling fertilizer when specific operating and cleanout procedures are followed.

***1.2.1 Misuse***

Do not install/use the conveyor for/with:

- transferring material other than dry, free-flowing food-grains.
- conveying canola, or any other oilseeds
- lifting or using as a hoist or crane.

# 2. Safety

## 2.1. Safety Alert Symbol and Signal Words



This safety alert symbol indicates important safety messages in this manual. When you see this symbol, be alert to the possibility of injury or death, carefully read the message that follows, and inform others.

**Signal Words:** Note the use of the signal words **DANGER**, **WARNING**, **CAUTION**, and **NOTICE** with the safety messages. The appropriate signal word for each message has been selected using the definitions below as a guideline.

**DANGER** Indicates an imminently hazardous situation that, if not avoided, will result in serious injury or death.

**WARNING** Indicates a hazardous situation that, if not avoided, could result in serious injury or death.

**CAUTION** Indicates a hazardous situation that, if not avoided, may result in minor or moderate injury.

**NOTICE** Indicates a potentially hazardous situation that, if not avoided, may result in property damage.

## 2.2. Follow Safety Instructions

Read and understand all safety instructions, safety decals, and manuals and follow them when operating or maintaining the equipment.

- Owners must give instructions and review the information initially and annually with all personnel before allowing them in the work area. Untrained users/operators expose themselves and bystanders to possible serious injury or death.
- Use for intended purposes only.
- Do not modify the conveyor in any way without written permission from the manufacturer and is not covered by the warranty.
- Follow a health and safety program for your worksite. Contact your local occupational health and safety organization for information.
- Follow applicable local codes and regulations.



## 2.3. Overhead Power Lines

**DANGER**

- When operating or moving, keep conveyor away from overhead power lines and devices.
- The conveyor is not insulated.
- Electrocution can occur without direct contact.



## 2.4. Moving Conveyor Belt Safety

---

### ⚠️ WARNING

- DO NOT step on or touch moving conveyor belt.
- Shut off and lock out power to adjust, service, or clean.



## 2.5. Upending

---

### ⚠️ WARNING

- Anchor intake end and/or support discharge end to prevent upending.
- Intake end must always have downward weight. Do not release until attached to tow bar or resting on ground.
- Do not raise intake end above tow bar height.
- Empty the conveyor and fully lower before moving.

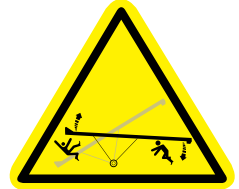

## 2.6. Rotating Parts Safety

---

### ⚠️ WARNING

- Keep body, hair, and clothing away from rotating pulleys, belts, chains, and sprockets.
- Do not operate with any guard removed or modified. Keep guards in good working order.
- Shut off and lock out power source before inspecting or servicing machine.



## 2.7. Work Area Safety

---

- Have another trained person nearby who can shut down the conveyor in case of accident.
- The work area should be kept clear of bystanders, including children.
- Keep the work area clean and free of debris.

Figure 1. Conveyor Work Area

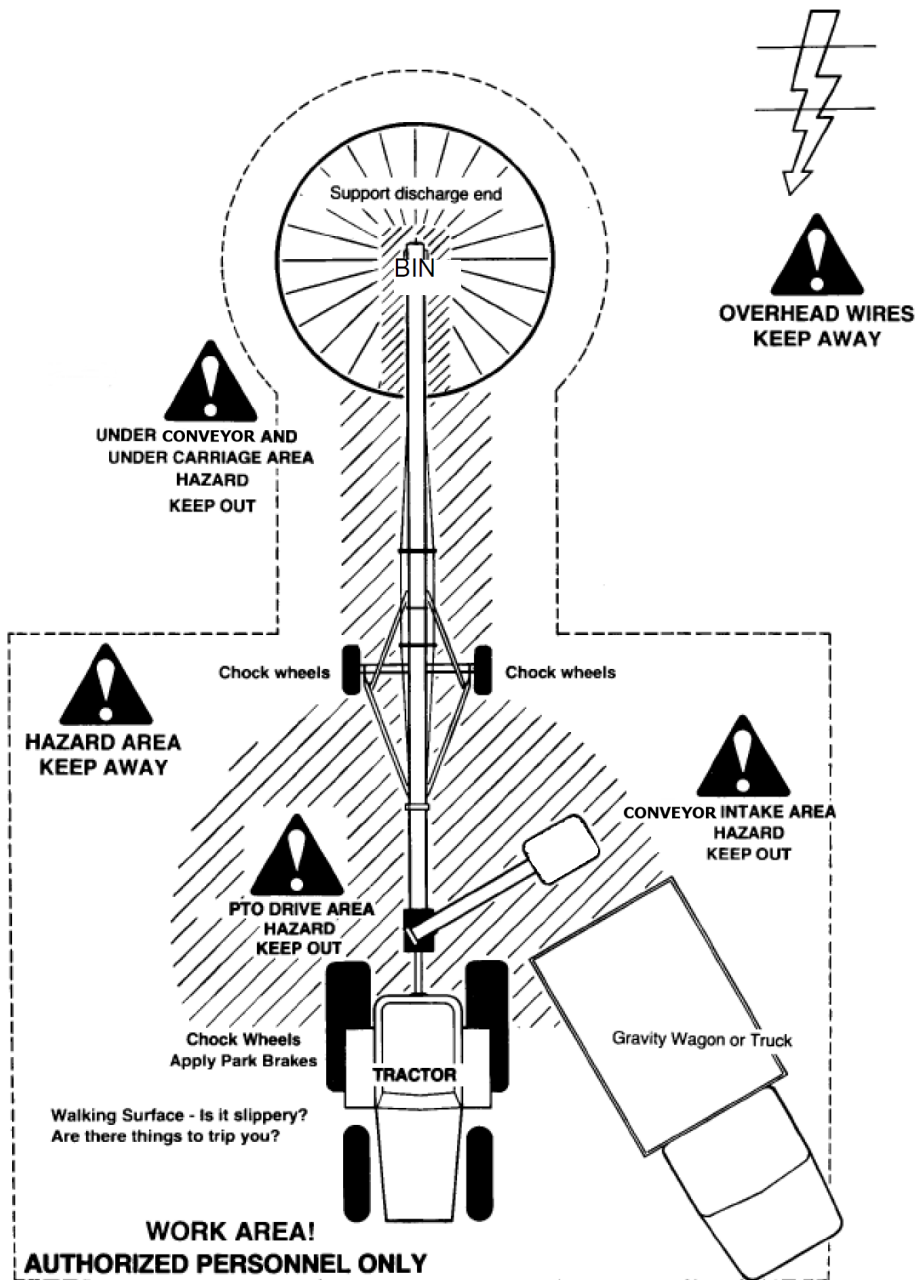

## 2.8. Guards Safety

- ⚠ WARNING**
- Keep guards in place. Do not operate with guard removed.
  - Do not walk on, step on, or damage guards.
  - Lock out power before removing a guard.
  - Ensure all guards are replaced after performing maintenance.

## 2.9. Raising and Lowering the Conveyor

---

- ⚠ WARNING**
- Before raising/lowering/moving/adjusting the conveyor, make sure the area around the conveyor is clear of obstructions and/or untrained personnel. Never allow anyone to stand on or beneath the conveyor when it is being placed.
  - Lower the conveyor to its lowest position when not in use.
  - Empty the conveyor before raising or lowering.
  - Do not get on or beneath the conveyor when raising or lowering.
  - Raise and lower conveyor on reasonably level ground only.
  - Never attempt to increase height of the conveyor by positioning wheels on lumber, blocks, or by any other means. To do so will result in damage to conveyor and/or serious injury.
  - Do not raise the conveyor in high winds.

## 2.10. Hydraulic Winch Safety

---

- ⚠ WARNING** When Equipped:
- Keep away from rotating cable drum and winch cable. Do not touch or grab cable while winch is being operated or use hands to guide the cable.
  - Inspect cable and cable clamps before using hydraulic winch. Replace cable if frayed or damaged. Tighten cable clamps if necessary.
  - Check the cable anchor on the winch drum is tight.
  - Confirm hydraulic hoses are in good condition.
  - Do not continue to supply power to hydraulic winch after the conveyor has reached full up position.
  - Do not disconnect hydraulic quick couplers when lines are pressurized.
  - Make sure lift cable is seated in cable pulley.
  - Always keep a minimum of 3 cable wraps on the cable drum.

## 2.11. Positioning the Conveyor

---

- ⚠ WARNING**
- Transport and place equipment on reasonably level ground when raising, lowering, positioning, or operating.
  - Move the conveyor into position slowly. Do not unhitch and attempt to move by hand.
  - Chock wheels and anchor intake end after placement.

## 2.12. Towing the Conveyor

---

The conveyor is not intended for transport on public roads. If it requires transport on a public roadway, the following steps should be taken:

**WARNING**

- Check with local authorities regarding transport on public roads. Obey all applicable laws and regulations.
- Always travel at a safe speed, never exceeding 20 mph (32 km/h).
- Reduce speed on rough surfaces.
- Do not transport on slopes greater than 20°.
- Use caution when turning corners or meeting traffic.
- Make sure the SMV (slow moving vehicle) emblem and all the lights and reflectors that are required by local authorities are in place, are clean, and can be seen by all over-taking and oncoming traffic.
- Always use hazard-warning flashers on tractor/towing vehicle when transporting unless prohibited by law.
- Do not allow riders on the conveyor or towing vehicle during transport.
- Attach to towing vehicle with an appropriate pin and retainer. Always attach safety chains.
- Place the conveyor in the transport position before moving on roads.

## 2.13. Drives and Lockout Safety

---

Inspect the power source(s) before using and know how to shut down in an emergency. Whenever you service or adjust your equipment, make sure you shut down the power source and unplug or remove the key (as applicable) to prevent inadvertent start-up and hazardous energy release. Know the procedure(s) that applies to your equipment from the following power source(s). Ensure that all personnel are clear before turning on power to equipment.

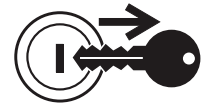

### 2.13.1 PTO Driveline Safety

**WARNING****Drive**

- Keep body, hair, and clothing away from rotating PTO driveline.
- Make certain the driveline shields telescope and rotate freely on driveline before attaching.
- Make certain the driveline is securely attached at both ends.
- Do not operate conveyor unless all driveline, tractor, and equipment shields are in place and in good working order.
- Do not exceed the specified operating speed.
- Keep universal joint angles small and equal. Do not exceed maximum recommended length for PTO driveline.
- Engage tractor park brake and/or chock wheels.

**Lockout**

- Position all controls in neutral, shut off tractor's engine, and remove key from tractor.
- If removing key is impossible, remove PTO driveline from tractor.

### 2.13.2 Hydraulic Power Safety

#### **WARNING** Power Source

- Refer to the rules and regulations applicable to the power source operating your hydraulic drive.
- Do not connect or disconnect hydraulic lines while system is under pressure.
- Keep all hydraulic lines away from moving parts and pinch points.
- Escaping hydraulic fluid under pressure will cause serious injury if it penetrates the skin surface (serious infection or toxic reaction can develop). See a doctor immediately if injured.
- Use metal or wood as a backstop when searching for hydraulic leaks and wear proper hand and eye protection.
- Check all hydraulic components are tight and in good condition. Replace any worn, cut, abraded, flattened, or crimped hoses.
- Clean the connections before connecting to equipment.
- Do not attempt any makeshift repairs to the hydraulic fittings or hoses with tape, clamps, or adhesive. The hydraulic system operates under extremely high pressure; such repairs will fail suddenly and create a hazardous and unsafe condition.

#### **Lockout**

- Always place all hydraulic controls in neutral and relieve system pressure before disconnecting or working on hydraulic system.



## 2.14. Tire Safety

**WARNING** Failure to follow proper procedures when mounting a tire on a wheel or rim can produce an explosion that may result in serious injury or death.



- DO NOT attempt to mount a tire unless you have the proper equipment and experience to do the job.
- Have a qualified tire dealer or repair service perform required tire maintenance.
- When replacing worn tires, make sure they meet the original tire specifications. Never undersize the replacement tire.
- DO NOT weld to the tire rim with the tire mounted on the rim. This action may cause an explosion which could result in serious injury or death.
- Inflate tires to the manufacturer's recommended pressure.
- Tires should not be operated at speeds higher than their rated speed.
- Keep wheel lug nuts tightened to manufacturer's recommendations.
- Never reinflate a tire that has been run flat or seriously under-inflated without removing the tire from the wheel. Have the tire and wheel closely inspected for damage before remounting.



## 2.15. Personal Protective Equipment

The following Personal Protective Equipment (PPE) should be worn when operating or maintaining the equipment.

### Safety Glasses

- Wear safety glasses at all times to protect eyes from debris.



### Coveralls

- Wear coveralls to protect skin.



### Hard Hat

- Wear a hard hat to help protect your head.



### Steel-Toe Boots

- Wear steel-toe boots to protect feet from falling debris.



### Work Gloves

- Wear work gloves to protect your hands from sharp and rough edges.



### Dust Mask

- Wear a dust mask to prevent breathing potentially harmful dust.



## 2.16. Safety Equipment

---

The following safety equipment should be kept on site.

### Fire Extinguisher

- Provide a fire extinguisher for use in case of an accident. Store in a highly visible and accessible place.



### First-Aid Kit

- Have a properly-stocked first-aid kit available for use should the need arise, and know how to use it.



## 2.17. Safety Decals

---

- Keep safety decals clean and legible at all times.
- Replace safety decals that are missing or have become illegible. See decal location figures that follow.
- Replaced parts must display the same decal(s) as the original part.
- Replacement safety decals are available **free of charge** from your distributor, dealer, or factory as applicable.

### 2.17.1 Decal Installation/Replacement

1. Decal area must be clean and dry, with a temperature above 50°F (10°C).
2. Decide on the exact position before you remove the backing paper.
3. Align the decal over the specified area and carefully press the small portion with the exposed sticky backing in place.
4. Slowly peel back the remaining paper and carefully smooth the remaining portion of the decal in place.
5. Small air pockets can be pierced with a pin and smoothed out using the decal backing paper.

### 2.17.2 Safety Decal Locations and Details

Replicas of the safety decals that are attached to the conveyor and their messages are shown in the figure(s) that follow. Safe operation and use of the conveyor requires that you familiarize yourself with the various safety decals and the areas or particular functions that the decals apply to, as well as the safety precautions that must be taken to avoid serious injury, death, or damage.

**Figure 2. Conveyor Safety Decal Locations**

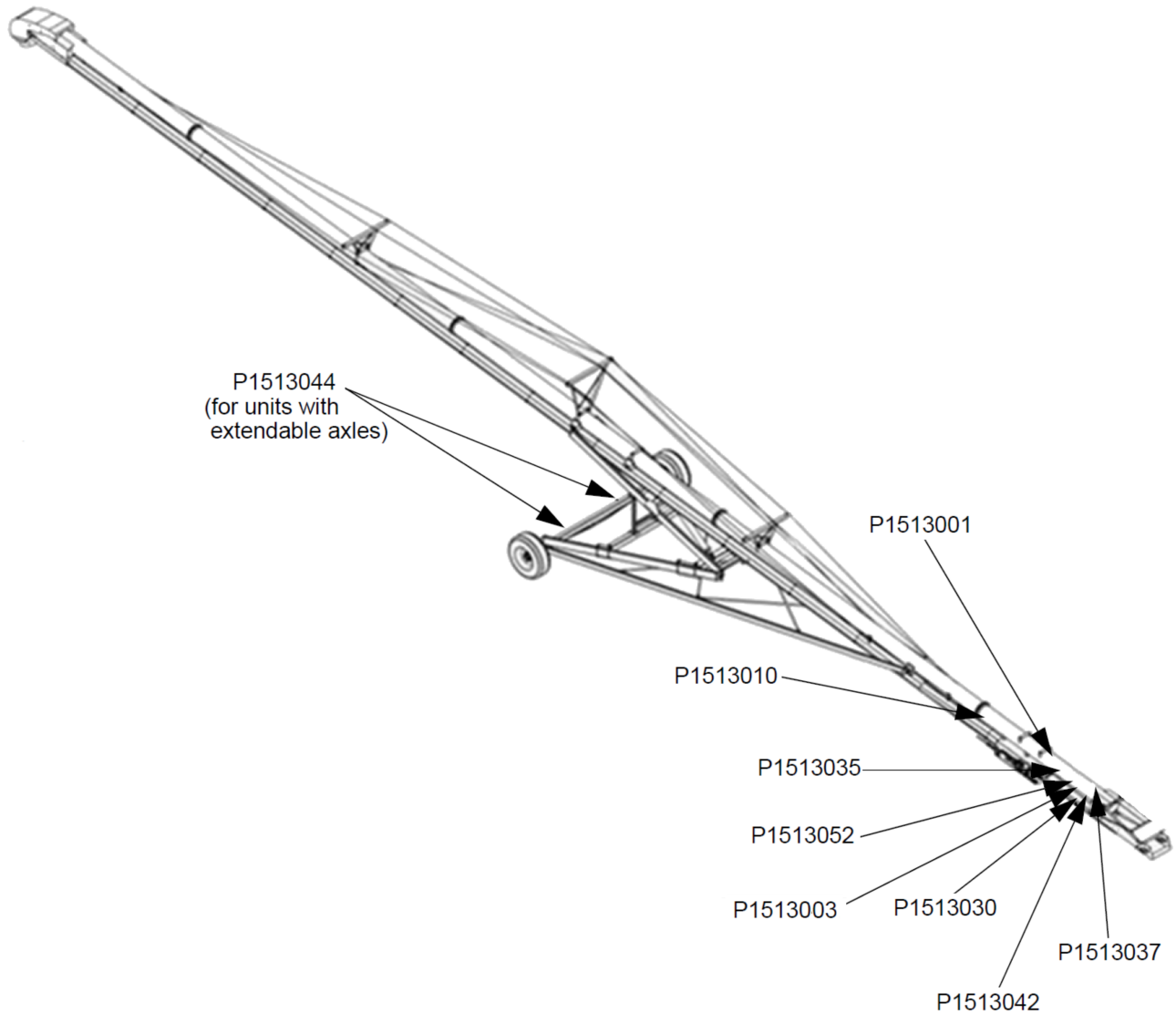
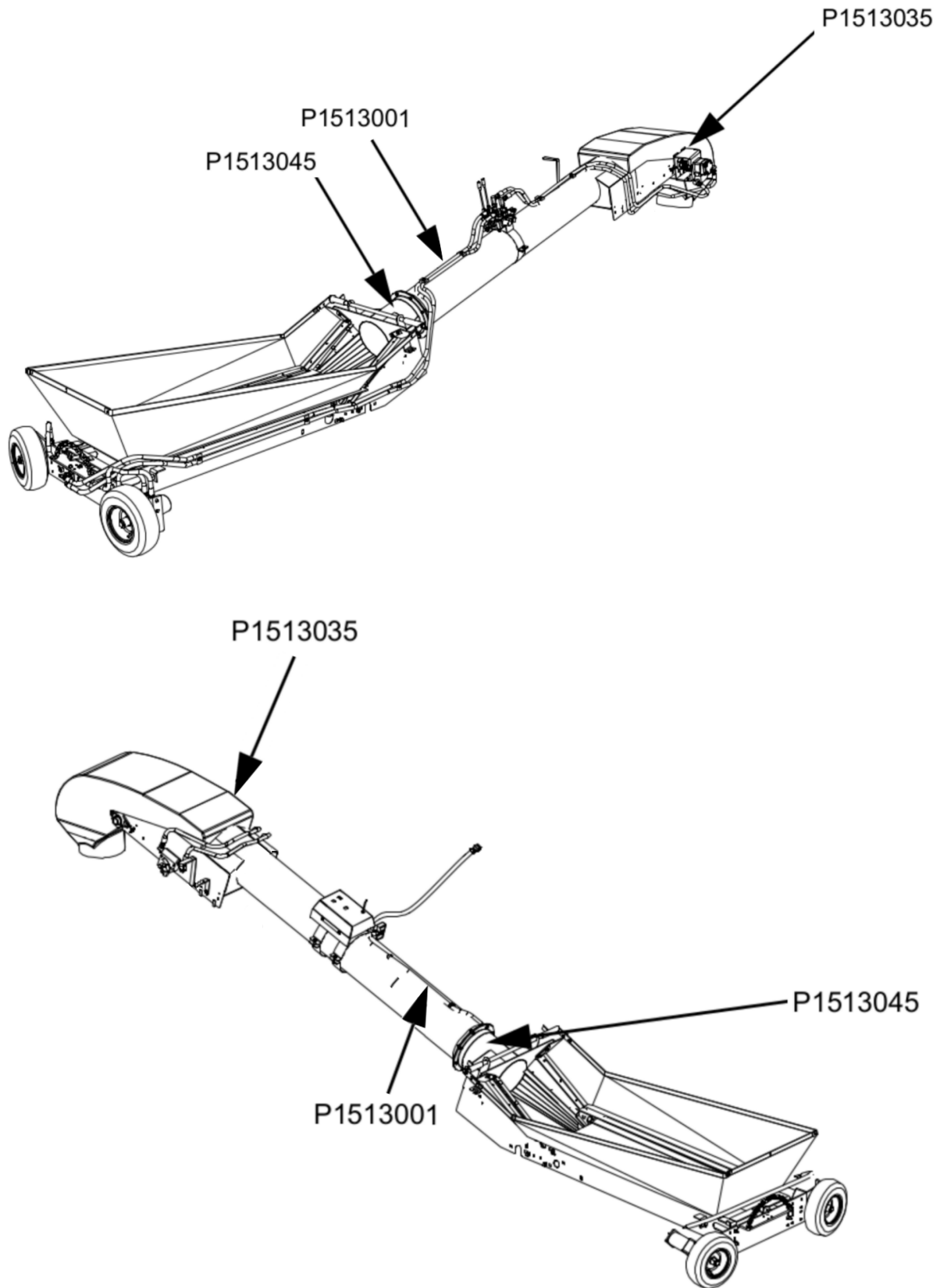
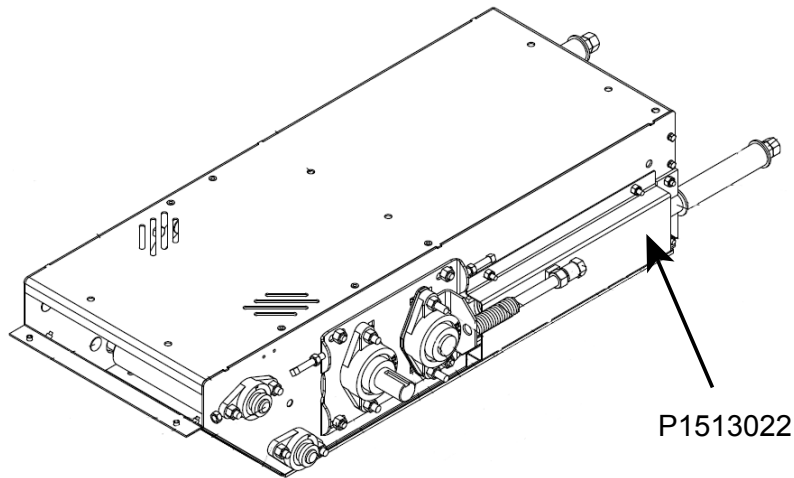

Figure 3. Swing Away Safety Decal Locations (Hydraulic and Electric Power Swings)



**Figure 4. S-Drive Safety Decal Locations**



**Figure 5. Safety Decal Locations for Front PTO Drive with Swing Away**

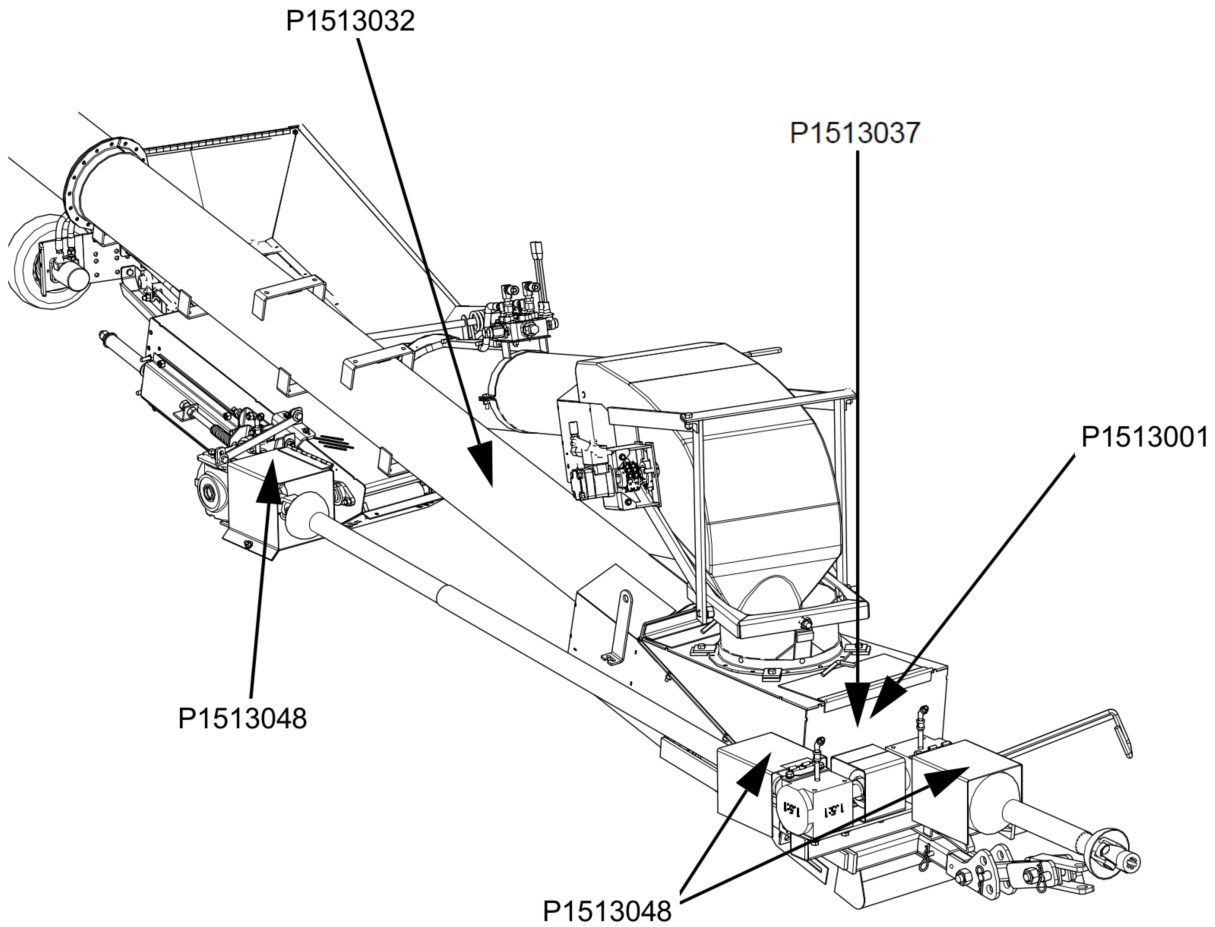
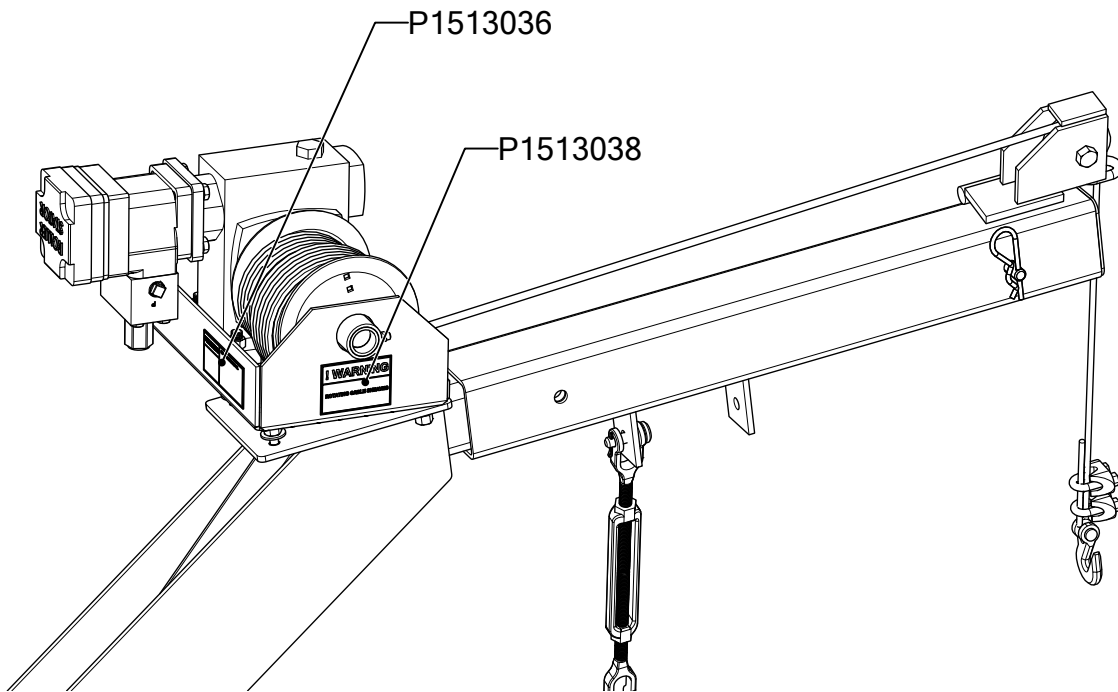

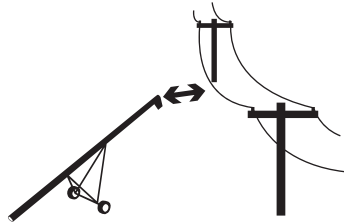

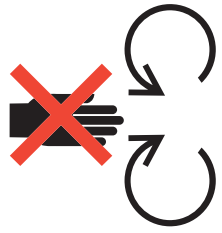



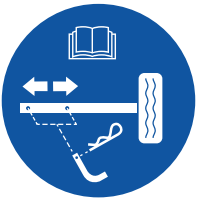

Figure 6. Transport Arm Safety Decal Locations



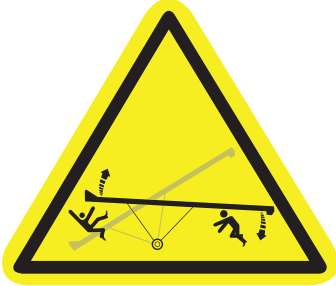

**Table 1. Safety Decals**

Part Number	Description
P1513003	<div style="border: 2px solid black; padding: 10px;"> <div style="background-color: red; color: white; text-align: center; padding: 5px;">  <b>DANGER</b> </div> <div style="display: flex; justify-content: space-around; align-items: center; margin-top: 10px;">   </div> <div style="text-align: center; margin-top: 10px;"> <p><b>ELECTROCUTION HAZARD</b></p> <p>To prevent death or serious injury:</p> <ul style="list-style-type: none"> <li>• When operating or moving, keep equipment away from overhead power lines and devices.</li> <li>• Fully lower equipment before moving.</li> </ul> <p>This equipment is not insulated.</p> <p>Electrocution can occur without direct contact.</p> </div> </div>
P1513048	<div style="border: 2px solid black; padding: 10px;"> <div style="display: flex; justify-content: space-between; align-items: center;"> <div style="width: 30%;">  </div> <div style="width: 65%; text-align: center;"> <div style="background-color: red; color: white; text-align: center; padding: 5px;">  <b>DANGER</b> </div> <p><b>ROTATING PTO DRIVELINE</b></p> <p>To prevent serious injury or death:</p> <ul style="list-style-type: none"> <li>• Keep body, hair, and clothing away from rotating PTO driveline.</li> <li>• Do not operate equipment unless all driveline, tractor, and equipment shields are in place and in good working order.</li> <li>• Make certain the driveline shields turn freely on driveline.</li> <li>• Make certain the driveline is securely attached at both ends.</li> <li>• Do not exceed specified operating speed (see operator's manual).</li> <li>• Keep u-joint angles small and equal. Do not exceed maximum recommended length for PTO driveline.</li> </ul> </div> </div> <div style="margin-top: 10px;">  </div> </div>



**Table 1 Safety Decals (continued)**

Part Number	Description
P1513044	<div style="display: flex; align-items: center;">   <div style="margin-left: 20px;"> <p><b>⚠ WARNING</b></p> <p><b>ROLLOVER / TRANSPORT HAZARD</b></p> <p>To prevent serious injury or death:</p> <ul style="list-style-type: none"> <li>• Fully extend axles before raising tube.</li> <li>• Retract axles before transporting.</li> </ul> </div> </div>
P1513035	<div style="border: 2px solid black; padding: 10px;"> <p style="text-align: center;"><b>⚠ WARNING</b></p> <div style="display: flex; justify-content: space-around;">   </div> <p style="text-align: center;"><b>HIGH PRESSURE FLUID HAZARD</b></p> <p>Hydraulic fluid can cause serious injury if it penetrates the skin. If it does, see a doctor immediately.</p> <ul style="list-style-type: none"> <li>• Relieve system pressure before repairing, adjusting or disconnecting.</li> <li>• Wear proper hand and eye protection when searching for leaks. Use wood or cardboard instead of hands.</li> </ul> </div>









**Table 1 Safety Decals (continued)**

Part Number	Description
P1513042	<div style="border: 2px solid black; padding: 10px;"> <div style="background-color: #f4a460; padding: 5px; text-align: center;">  <span style="font-size: 24px; font-weight: bold; color: white;">WARNING</span> </div> <div style="display: flex; justify-content: space-around; margin-top: 10px;"> <div style="text-align: center;">  </div> <div style="text-align: center;">  </div> </div> <div style="text-align: center; margin-top: 10px;"> <p><b>UPENDING HAZARD</b></p> <p>To prevent death or serious injury:</p> <ul style="list-style-type: none"> <li>Anchor intake end and/or support discharge end to prevent upending.</li> <li>Intake end must always have downward weight. Do not release until attached to tow bar or resting on ground.</li> <li>Do not raise intake end above tow bar height.</li> <li>Empty tube and fully lower before moving.</li> </ul> </div> </div>
P1513037	<div style="border: 2px solid black; padding: 10px;"> <div style="background-color: #f4a460; padding: 5px; text-align: center;">  <span style="font-size: 24px; font-weight: bold; color: white;">WARNING</span> </div> <div style="text-align: center; margin-top: 10px;"> <p><b>TRANSPORT HAZARD</b></p> <p>To prevent serious injury or death:</p> <ul style="list-style-type: none"> <li>Securely attach equipment to vehicle with correct pin and safety chains.</li> <li>Use a tow vehicle to move equipment.</li> </ul> </div> </div>





**Table 1 Safety Decals (continued)**

Part Number	Description
P1513001	<div style="border: 2px solid black; padding: 10px;"> <div style="background-color: #f4a460; padding: 5px; text-align: center; border: 1px solid black;">  <span style="font-size: 24px; font-weight: bold; color: white;">WARNING</span> </div> <div style="display: flex; justify-content: space-around; margin-top: 10px;"> <div style="text-align: center;">  </div> <div style="text-align: center;">  </div> </div> <div style="margin-top: 10px;"> <p>To prevent serious injury or death:</p> <ul style="list-style-type: none"> <li>• Read and understand the manual before assembling, operating, or maintaining the equipment.</li> <li>• Only trained personnel may assemble, operate, or maintain the equipment.</li> <li>• Children and untrained personnel must be kept outside of the work area.</li> <li>• Do not modify the equipment. Keep in good working order.</li> <li>• If the manual, guards, or decals are missing or damaged, contact factory or representative for free replacements.</li> <li>• Lock out power before performing maintenance.</li> <li>• To prevent equipment collapse or upending, support equipment tube while disassembling certain components.</li> <li>• Follow grain storage structure manufacturer's warnings when loading and unloading.</li> <li>• Electric motors must be grounded. Disconnect power before resetting overloads.</li> </ul> </div> </div>

**Table 1 Safety Decals (continued)**

Part Number	Description
P1513045	<div style="border: 2px solid black; padding: 10px;"> <div style="background-color: #f4a460; padding: 5px; text-align: center; font-weight: bold; font-size: 1.2em;">  <b>WARNING</b> </div> <div style="display: flex; justify-content: space-around; align-items: center; margin: 10px 0;">   </div> <div style="text-align: center; font-weight: bold; font-size: 1.2em;"> <b>OPEN BELT CONVEYOR</b> </div> <p>To prevent death or serious injury:</p> <ul style="list-style-type: none"> <li>• DO NOT step on or touch moving conveyor belt.</li> <li>• Shut off and lock out power to adjust, service, or clean.</li> </ul> </div>
P1513036	<div style="border: 2px solid black; padding: 10px;"> <div style="display: flex; justify-content: space-between; align-items: center; margin-bottom: 10px;">  <div style="background-color: #f4a460; padding: 5px; text-align: center; font-weight: bold; font-size: 1.2em;">  <b>WARNING</b> </div> </div> <div style="text-align: center; font-weight: bold; font-size: 1.2em; margin-bottom: 5px;"> <b>HIGH PRESSURE FLUID HAZARD</b> </div> <p>Hydraulic fluid can cause serious injury if it penetrates the skin. If it does, see a doctor immediately.</p> <ul style="list-style-type: none"> <li>• Relieve system pressure before repairing, adjusting or disconnecting.</li> <li>• Wear proper hand and eye protection when searching for leaks. Use wood or cardboard instead of hands.</li> </ul> <div style="display: flex; justify-content: space-between; align-items: center; margin-top: 10px;">  </div> </div>
P1513038	<div style="border: 2px solid black; padding: 10px;"> <div style="display: flex; justify-content: space-between; align-items: center; margin-bottom: 10px;">  <div style="background-color: #f4a460; padding: 5px; text-align: center; font-weight: bold; font-size: 1.2em;">  <b>WARNING</b> </div> </div> <div style="text-align: center; font-weight: bold; font-size: 1.2em; margin-bottom: 5px;"> <b>WARNING</b> </div> <p>To prevent death or serious injury:</p> <ul style="list-style-type: none"> <li>• Keep away from rotating cable drum and winch cable.</li> <li>• Inspect lift cable periodically; replace if damaged.</li> <li>• Inspect cable clamps periodically; tighten if necessary.</li> </ul> <div style="display: flex; justify-content: space-between; align-items: center; margin-top: 10px;">  </div> </div>

**Table 1 Safety Decals (continued)**

Part Number	Description
P1513010	<div style="border: 2px solid black; padding: 10px;"> <div style="background-color: yellow; text-align: center; padding: 5px;">  <span style="font-size: 24pt; font-weight: bold; margin-left: 10px;">CAUTION</span> </div> <p style="margin-top: 10px;">To prevent personal injury or damage to equipment, close valve in lift cylinder hydraulic line after raising equipment into position.</p> </div>
P1513030	<div style="border: 2px solid black; padding: 10px;"> <div style="background-color: yellow; text-align: center; padding: 5px;">  <span style="font-size: 24pt; font-weight: bold; margin-left: 10px;">CAUTION</span> </div> <div style="display: flex; justify-content: space-around; margin-top: 10px;"> <div style="text-align: center;">  </div> <div style="text-align: center;">  </div> </div> <p style="margin-top: 10px;"><b>NOT A STEP - SLIP HAZARD</b> To prevent injury or damage to the equipment, do not use belt guard as a step.</p> </div>
P1513052	<div style="border: 2px solid black; padding: 10px;"> <div style="background-color: blue; color: white; text-align: center; padding: 5px; font-weight: bold; font-size: 24pt;">             NOTICE         </div> <p style="margin-top: 10px;">To prevent damage, wheels must be free to move when raising or lowering equipment.</p> <p style="margin-top: 10px;">When equipment is positioned, chock all wheels.</p> </div>

**Table 1 Safety Decals (continued)**

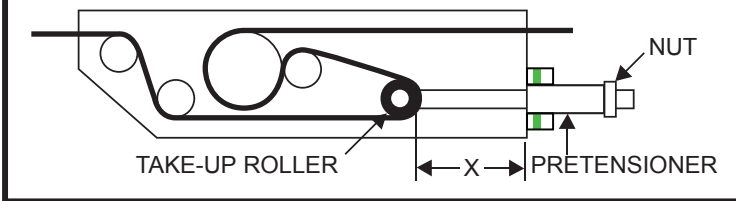
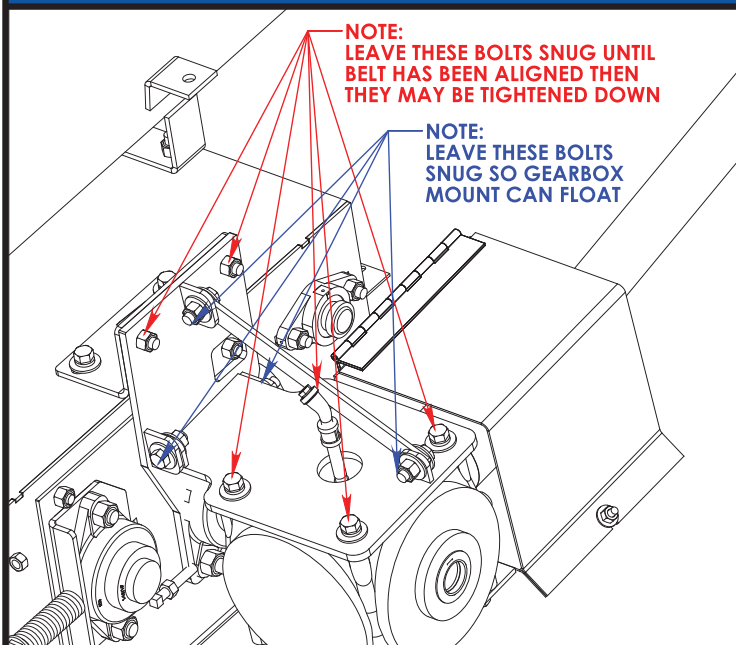
Part Number	Description
P1513022	<div style="border: 1px solid black; padding: 10px;"> <p style="text-align: center; background-color: #0056b3; color: white; font-weight: bold; font-size: 1.2em; margin: -10px -10px 10px -10px;">NOTICE</p>  <p>To prevent belt damage, use correct belt tension and do not attempt to adjust belt tracking with the take-up roller.</p> <p>To set correct belt tension:</p> <ul style="list-style-type: none"> <li>• While conveyor is running empty, tighten nut against the pretensioner (take-up pipe) so that the edge of the indicator pipe is within the green area.</li> <li>• Ensure take-up roller is tensioned equally by using a tape to measure distance "X".</li> <li>• After the conveyor belt has been tensioned, check the alignment of all other s-drive rollers and periodically afterward.</li> </ul> <p>See manual for complete instructions.</p> </div>
P1513032	<div style="border: 1px solid black; padding: 10px;"> <p style="text-align: center; background-color: #0056b3; color: white; font-weight: bold; font-size: 1.2em; margin: -10px -10px 10px -10px;">NOTICE</p>  <p style="color: red; font-weight: bold; font-size: 0.8em;">NOTE: LEAVE THESE BOLTS SNUG UNTIL BELT HAS BEEN ALIGNED THEN THEY MAY BE TIGHTENED DOWN</p> <p style="color: blue; font-weight: bold; font-size: 0.8em;">NOTE: LEAVE THESE BOLTS SNUG SO GEARBOX MOUNT CAN FLOAT</p> <p>To prevent damage, tighten/snug bolts as shown when assembling or maintaining the conveyor.</p> </div>

# 3. Features

Read this section to familiarize yourself with the basic component names and functions of the conveyor.

**Figure 7. Typical Swing-Away Conveyor Components (Scissor-Lift Conveyor)**

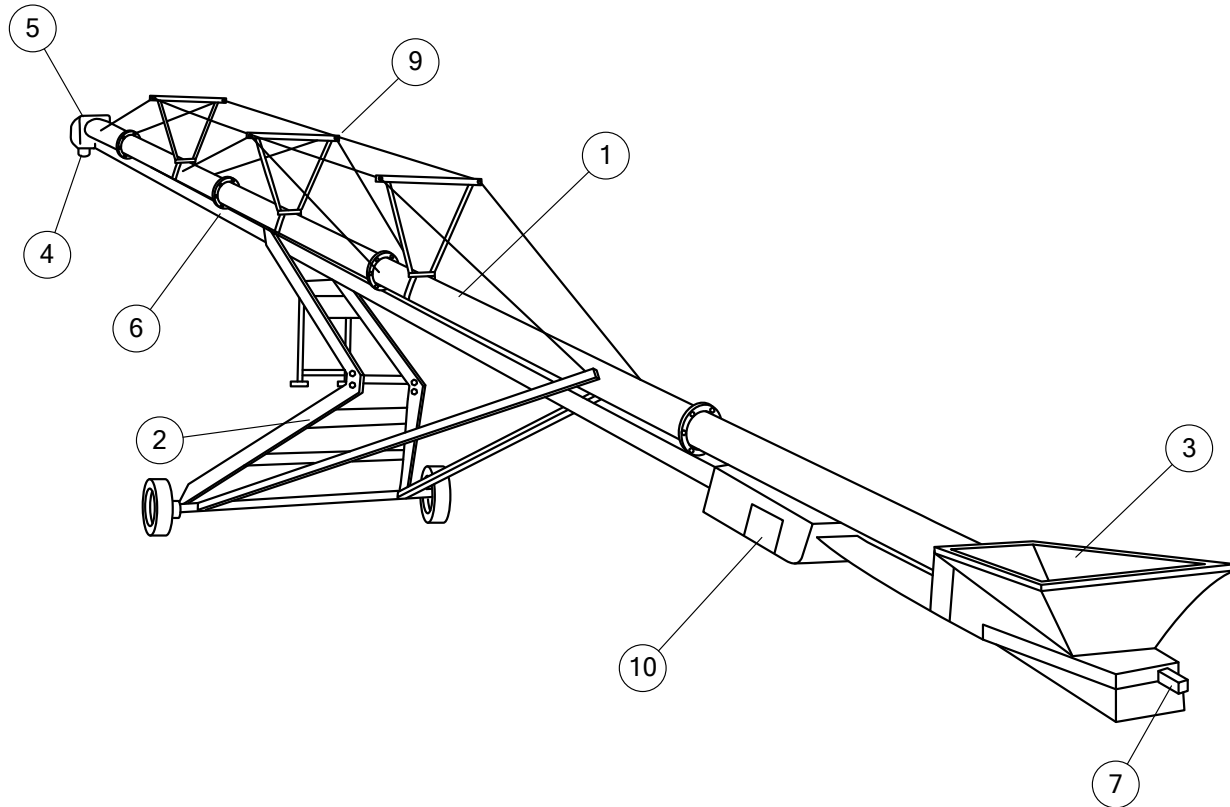
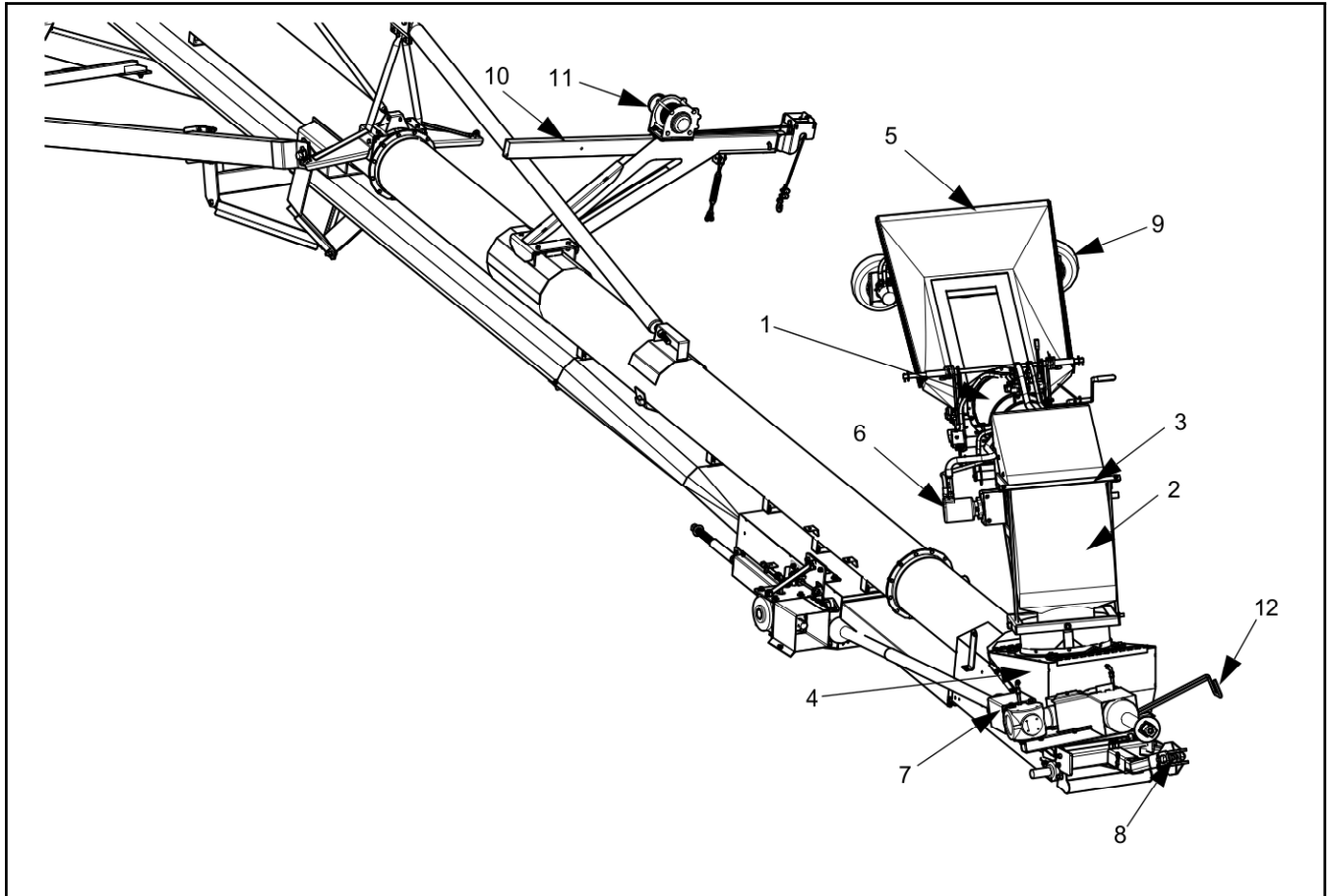

**Table 2. Typical Swing-Away Conveyor Components (Scissor-Lift Conveyor)**

Item	Description
1	Tube
2	Scissor Frame
3	Hopper
4	Spout Assembly
5	Hood

Item	Description
6	Belt Return and Weather Guard
7	Hitch
8	Jack (not shown)
9	Cable Truss
10	S-Drive

**Figure 8. Typical Swing-Away Conveyor Components**



**Table 3. Typical Swing-Away Conveyor Components**

Item	Description	Item	Description
1	Swing Away Hopper Conveyor	7	Front PTO Drive
2	Spout Assembly	8	Hitch
3	Spout Support Braces	9	Swing Away Wheels
4	Main Conveyor Boot	10	Transport Arm
5	Hopper	11	Hydraulic Winch
6	Hydraulic Motor	12	PTO Cradle

### 3.1. Model Number

---

**XXXX SA**

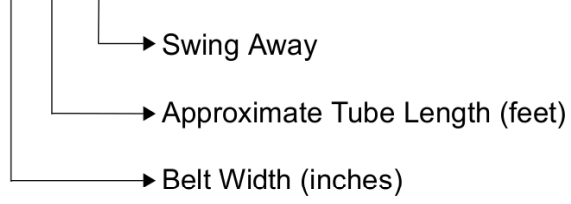

# 4. Transport



Before continuing, ensure you have completely read and understood this manual's Safety section, in addition to the safety information in the section(s) below.

## 4.1. Transport Safety

---

### **WARNING**

- Check with local authorities regarding transport on public roads. Obey all applicable laws and regulations.
- Always travel at a safe speed, never exceeding 20 mph (32 km/h). Reduce speed on rough surfaces. Use caution when turning corners or meeting traffic.
- Yield to other drivers and allow faster traffic to pass.
- Make sure the SMV (slow moving vehicle) emblem and all the lights and reflectors that are required by local authorities are in place, are clean, and can be seen by all over-taking and oncoming traffic. Always use hazard-warning flashers on tractor/towing vehicle when transporting unless prohibited by law.
- Do not transport during times of limited visibility such as fog, snow, or heavy rain. Take extra precautions at night and at dusk.
- Keep others away from the transport vehicle and conveyor.
- Do not allow riders on the conveyor or towing vehicle during transport.
- Stay away from overhead obstructions and power lines when operating and transporting. Electrocutation can occur without direct contact.
- Fully lower the conveyor before transporting, and only raise when next to storage facility.
- Attach to a proper towing vehicle with a pin and retainer. Always attach safety chain(s).
- Do not raise the intake end above drawbar, upending may occur.
- Empty conveyor of all grain or seed before transporting. Transporting a full conveyor will place excessive loads on the tube, frame, axle, hitch, and tow vehicle.
- Do not transport on slopes greater than 20°.
- Do not transport with an under-inflated tire(s).
- If the conveyor wheels are partially or fully buried in snow or grain, failure to clear area around the wheels before transporting may cause damage to the conveyor or result in serious injury.

## 4.2. Transport Preparation

---

1. It is not recommended that the conveyor be transported faster than 20 mph (32 km/h). [Table 4](#) references the acceptable transport speed as per the ratio of tractor weight versus conveyor weight. See Specifications ([Section 9. – Specifications on page 69](#)) for conveyor weights.

### **WARNING**

A weight imbalance between the conveyor and the towing vehicle could result in a collision from reduced stability, handling, and braking ability.

2. Ensure the conveyor will clear any overhead obstructions or electrical wires prior to transporting. Refer to [Section 9. – Specifications on page 69](#) for the transport height of your conveyor.

- Longer conveyors have a large turning radius. Allow ample room for turning as the discharge end may swing dramatically. Allow all oncoming traffic to pass before turning right or left.

**WARNING**

A collision with an oncoming vehicle could occur if the conveyor discharge swings into the opposing lane.

**Table 4. Speed versus Weight Ratio**

Road Speed	Weight or fully equipped or loaded implement(s) relative to weight of towing machine
Up to 32 km/h (20 mph)	1 to 1, or less
Up to 16 km/h (10 mph)	2 to 1, or less
Do not tow if	More than 2 to 1

### 4.3. Connecting the Conveyor to the Towing Vehicle

This section provides an overview of how to connect the conveyor to the towing vehicle. For specific information on the components, refer to the applicable section.

Follow all safety precautions when transporting the conveyor and use a proper towing vehicle.

- Fully lower the conveyor, there should be slight tension on the lift cable.
- Connect the conveyor to the tow vehicle with a hitch pin. Use a hitch pin that will not allow the conveyor to separate from the towing vehicle.
- Connect a safety chain securely, forming a cradle to prevent the conveyor from digging into the road surface (should a breakaway occur). Do not use the safety chain if one or more links or end fittings are stretched, broken, damaged, or deformed.

**Important**

Use a safety chain with a load rating at least as high as the conveyor weight.

- Use caution when transporting the conveyor over rolling terrain. In severe dips, the intake end may contact the ground.

Refer to [Section 9. – Specifications on page 69](#) for conveyor weight and hitch pin information.

# 5. Placement



Before continuing, ensure you have completely read and understood this manual's Safety section, in addition to the safety information in the section(s) below.

## 5.1. Placement Safety

---

### **WARNING**

- The conveyor is not insulated, keep away from overhead power lines. Electrocution can occur without direct contact.
- Anchor intake end before using.
- Place the conveyor on reasonably level ground before operating. The conveyor could topple if ground is too uneven.
- Chock the conveyor wheels after placement.
- Empty the conveyor before raising, lowering, or positioning.
- Check that wheels are free to move before raising or lowering the conveyor.
- Never attempt to increase height of the conveyor by positioning wheels on lumber, blocks, or by any other means.
- Do not permit anyone to stand beneath the conveyor when raising or lowering.
- Move the conveyor into position slowly. Do not unhitch and attempt to move by hand.
- Do not leave conveyor in raised position when not in use.

## 5.2. Positioning the Conveyor

---

### Filling Bins

The conveyor is designed to be transported and operated without unhitching unit from tractor.

1. Disconnect the PTO driveline from the tractor and secure it in the transport saddle.

### **NOTICE**

Failure to disconnect from the tractor will damage the PTO driveline.

2. Ensure that the tractor and conveyor are securely hitched together.

### **Important**

Use a type of hitch pin (see Conveyor / Tractor Hookup section) that will not allow the conveyor to separate from towing vehicle.

3. Disconnect the safety chain from the intake hopper.
4. Before connecting the hydraulics, ensure that the quick-connect coupler on the conveyor and tractor is clean and free of dirt by wiping with a cloth.



### **WARNING**

Dirt in the hydraulic system can damage the cylinder o-rings, causing leakage and the possible failure of the system and personal injury.

5. Connect hydraulic hoses, ensure connections are tight. Check for leaks, binding, flattening, kinks, or wear.
6. **Where Equipped:** Fully extend wheel axles, see Extendable Axle Positioning.
7. Adjust the hitch to the operating position, refer to Hitch Adjustment.

8. Move the jack into storage position.
9. Raise the main conveyor tube as required, see Raising and Lowering.
10. Move the conveyor into working position slowly. Do not unhitch and attempt to move the conveyor by hand.
11. Back the conveyor up to the storage facility while it is in its lowered configuration.
12. Raise the conveyor so it clears the storage facility. See **Raising and Lowering**.
13. Slowly back the conveyor up until the outlet is over the opening in the storage facility.
14. Slowly lower the conveyor to the bin.
15. Set the park brake on the tractor before dismounting, or chock its wheels.
16. Once the conveyor is in position, chock its wheels.
17. Lower the intake hopper to the ground, see Raising and Lowering the Intake Hopper.
18. See Operation for correct operating procedures.

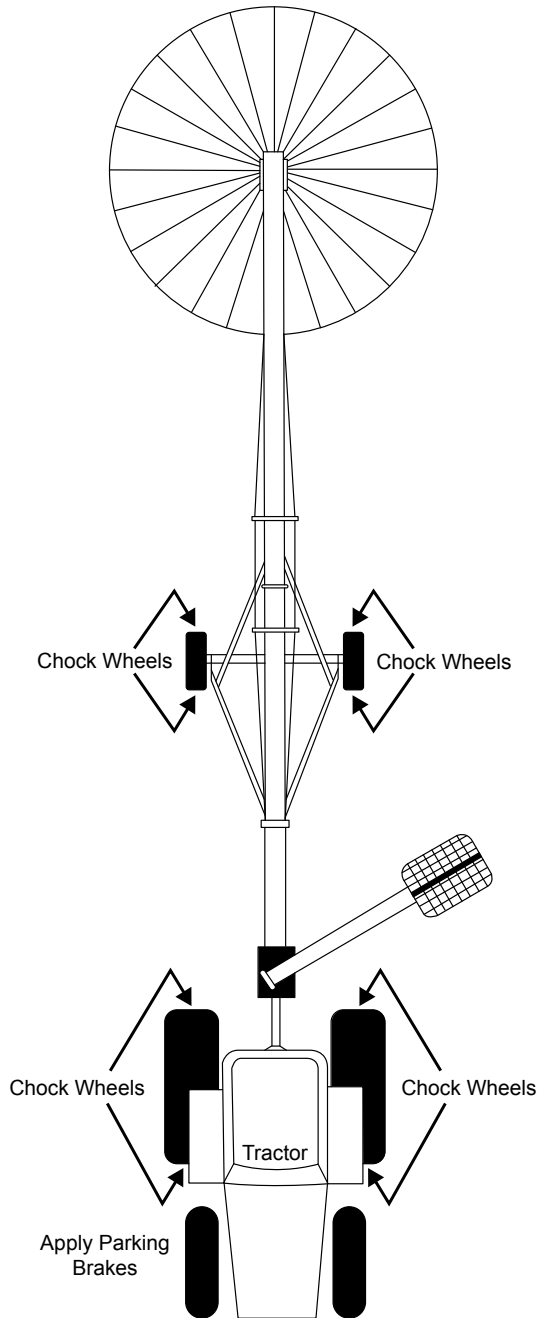
**Figure 9. Conveyor Placement (Direct PTO Drive)**

### 5.2.1 Raising and Lowering

The intake hopper must be off the ground when raising and lowering the conveyor.

#### Before using the hydraulic lift cylinder:

- The hydraulic cylinders are shipped without oil and must be charged with oil before operating the first time. See the Appendix section for charging instructions.
- Check that the hydraulic hoses are free from leaks, binding, flattening, kinks, or wear.

## Raising

1. Before connecting the hydraulic hose, wipe the hose coupler clean.

### NOTICE

Dirt in the hydraulic system can damage the cylinder o-rings and can cause leakage and failure of the system.

2. Connect the hydraulic hoses, ensure the connections are tight. Visually check for leaks, binding, flattening, kinks, or wear.
3. Open the ball valve on the hose connected to the cylinder.
4. Start tractor and idle at low rpm.
5. Engage hydraulic lever to power the cylinder.
6. Increase tractor rpm until desired rate of lift is reached.
7. Raise the conveyor to the desired height.
8. Close the hydraulic ball valve when the conveyor is fully raised.

### NOTICE

Failure to close the ball valve may cause the frame to creep lower, potentially damaging the conveyor.

## Lowering:

1. Reconnect the hydraulic hose coupler to tractor, if disconnected. Keep the tractor running while lowering the conveyor should the need arise to re-lift it.

### NOTICE

Some conveyors are equipped with dual acting hydraulic cylinders, for these units the tractor must be running to pump oil to the upper chamber of the hydraulic cylinder(s) to prevent overfilling of the tractor reservoir.

2. Open the ball valve.
3. Open the tractor valve, feathering the control to prevent too rapid a descent.

### Note

Once the valves are opened, the conveyor tube lowers by gravity. As the tube nears the full down position, the rate of descent will increase. Do not operate with the tractor valve fully open.

4. Turn off the tractor, and lock out the tractor power source.
5. Before disconnecting hydraulic couplers, relieve the hydraulic pressure.

### ⚠ WARNING

Disconnecting a hydraulic hose under pressure can result in serious injury.

## 5.3. Extendable Axle Positioning

---



When equipped with extendable axles:

### Important

Do not raise the conveyor unless the axles are in the extended position. Do not transport the conveyor unless the axles are in the retracted position.

### ⚠ WARNING

Rollover can occur if axles are not extended before raising the conveyor.

1. Ensure the conveyor is on level ground before attempting to extend or retract the axles. **The conveyor must be attached to tractor at all times.**

2. Using the jack supplied, insert it into one of the jack stubs located on one end of the axle. Jack must be secured to jack stub using pin (attached to jack).
3. Raise one side at a time. Raise until the tire clears the ground.
4. Remove the axle pin from the axle and position the axle as desired until the holes line up. Reinsert the axle pin and secure with hairpin. Lower the jack.
5. Repeat the process on the opposite side of the axle.

**Figure 10. Typical Extendable Axle**

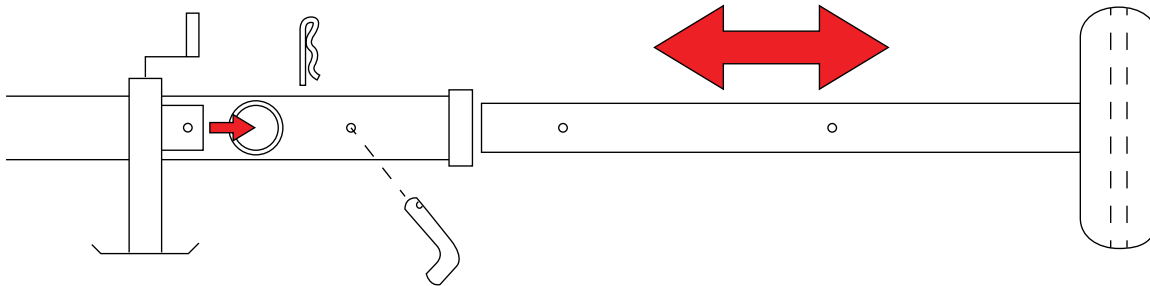

## 5.4. Raising and Lowering

➡ When equipped with a Hydraulic Lift Cylinder:

The intake hopper must be off the ground when raising and lowering the conveyor.

### Before using the hydraulic lift cylinder:

- The hydraulic cylinders are shipped without oil and must be charged with oil before operating the first time. See the Appendix section for charging instructions.
- Check that the hydraulic hoses are free from leaks, binding, flattening, kinks, or wear.

### Raising

1. Before connecting the hydraulic hose, wipe the hose coupler clean.

#### NOTICE

Dirt in the hydraulic system can damage the cylinder o-rings and can cause leakage and failure of the system.

2. Connect the hydraulic hoses, ensure the connections are tight. Visually check for leaks, binding, flattening, kinks, or wear.
3. Open the ball valve on the hose connected to the cylinder.
4. Start tractor and idle at low rpm.
5. Engage hydraulic lever to power the cylinder.
6. Increase tractor rpm until desired rate of lift is reached.
7. Raise the conveyor to the desired height.
8. Close the hydraulic ball valve when the conveyor is fully raised.

**NOTICE**

Failure to close the ball valve may cause the frame to creep lower, potentially damaging the conveyor.

**Lowering:**

1. Reconnect the hydraulic hose coupler to tractor, if disconnected. Keep the tractor running while lowering the conveyor should the need arise to re-lift it.

**NOTICE**

Some conveyors are equipped with dual acting hydraulic cylinders, for these units the tractor must be running to pump oil to the upper chamber of the hydraulic cylinder(s) to prevent overfilling of the tractor reservoir.

2. Open the ball valve.
3. Open the tractor valve, feathering the control to prevent too rapid a descent.

**Note**

Once the valves are opened, the conveyor tube lowers by gravity. As the tube nears the full down position, the rate of descent will increase. Do not operate with the tractor valve fully open.

4. Turn off the tractor, and lock out the tractor power source.
5. Before disconnecting hydraulic couplers, relieve the hydraulic pressure.

**WARNING**

Disconnecting a hydraulic hose under pressure can result in serious injury.

6. Adjust the conveyor in the full down position until there is a slight tension on the lift cable. Do not leave the cable slack.

## 5.5. Hitch Adjustment

---

Before operating the conveyor, confirm that dimensions A, B, and C, are within the limits stated in [Figure 11](#) when the PTO is connected to the tractor.

This does not apply to the 2000 Series Swing Away Conveyor.

**Note**

The dimensions in [Figure 11](#) are based on the adjustable hitch being in position 2.

**Figure 11. Hitch Adjustment Tolerance**

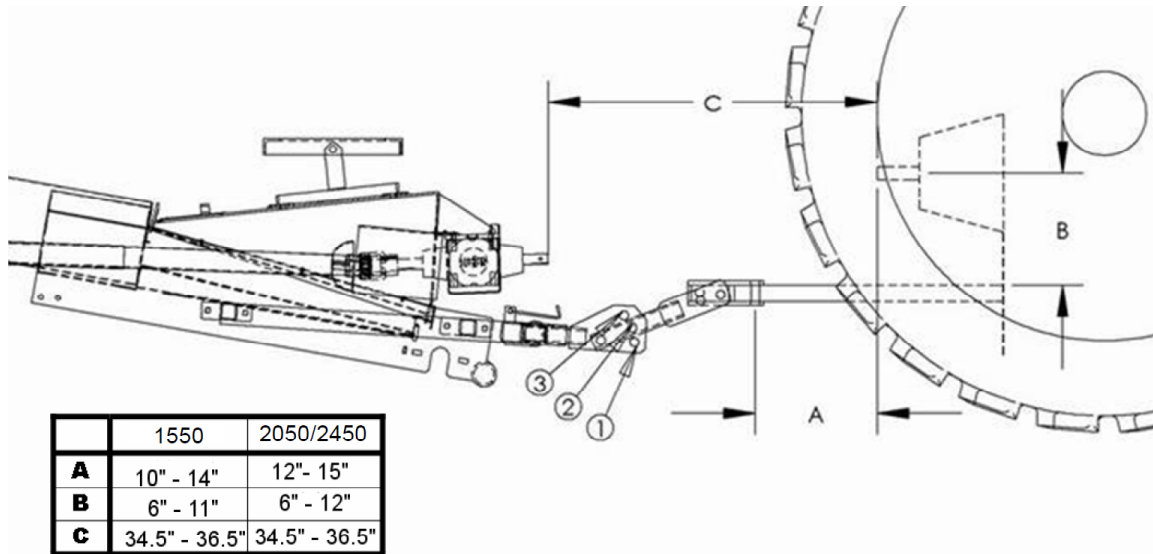

**If dimension C is greater than the hitch adjustment tolerance**

The PTO driveline will separate causing potential damage to equipment and/or operators.

1. With the conveyor completely lowered, adjust the hitch to position 1.
2. If dimension C is still too large, move the draw bar closer to the tractor until dimensions A and C are within the bounds given.

**If dimension C is less than the hitch adjustment tolerance**

The PTO driveline will bottom out causing potential damage to equipment and/or operators.

1. With the conveyor completely lowered, adjust the hitch to position 3.
2. If dimension C is still too small, move the draw bar further from the tractor until dimensions A and C are within the bounds given.

**If dimension B is greater than the hitch adjustment tolerance**

The PTO driveline will shorten at a higher rate as the conveyor is raised causing the PTO to bottom out, which will damage the equipment. The angle between the u-joints in the driveline will also become too large and damage may occur.

1. Raise the level of the drawbar such that dimension B is within the given parameters.

## 5.6. Extended Swing Arm

The swing-away conveyor is equipped with an extendable swing transport arm. The purpose of this arm is to move the transfer in for transporting. With the arm extended, the transfer can be dropped to the ground without interference at any conveyor elevation. To adjust the transport arm for use on the road:

- Disconnect the safety catch.
- Lower the transfer to ground.
- Remove the pin from the extendable arm and slide the pin into transport position.

- Lift the transfer using winch and connect the transport safety catch.

**WARNING** Never transport conveyor on roads with transfer attached to swing arm in the extended position. The extendable swing should be in the extended position for off-road use only.

**Figure 12. Extended Swing Arm**

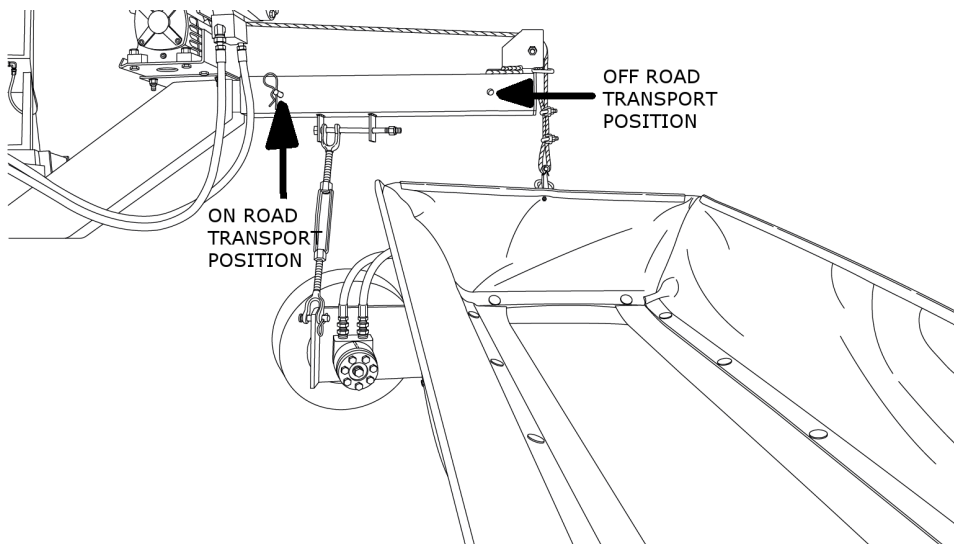

## 5.7. Raising and Lowering the Intake Hopper

1. Position the swing-away transfer under the transport arm.
2. Loosen the lift cable and connect it to the transfer hopper. Lift the swing-away transfer into the transport position using the hydraulic winch lift.

**Figure 13. Swing Away Transfer Lift Winch**

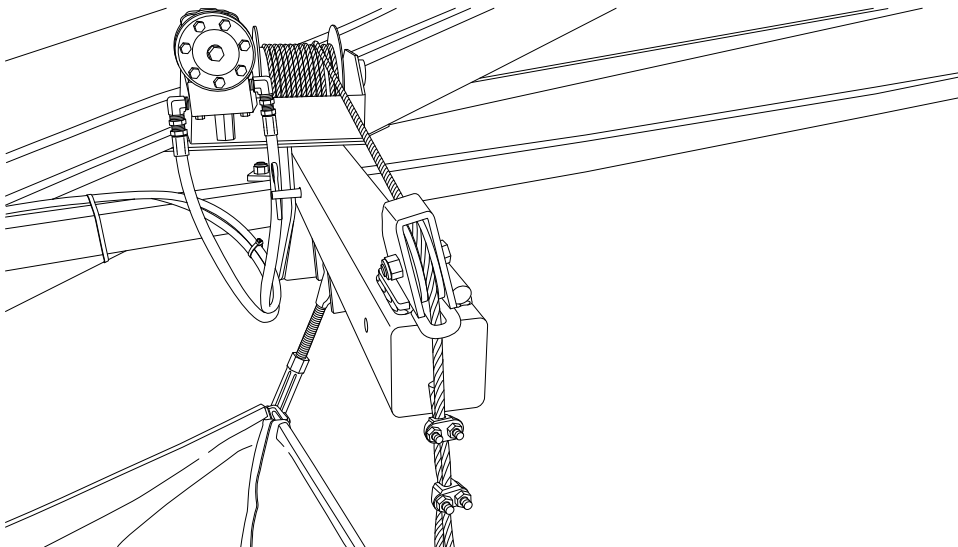

3. Connect the swing catch.
4. Attach the winch cable hook to the appropriate hopper lifting point.
5. Reverse the procedure to lower the swing-away transfer.

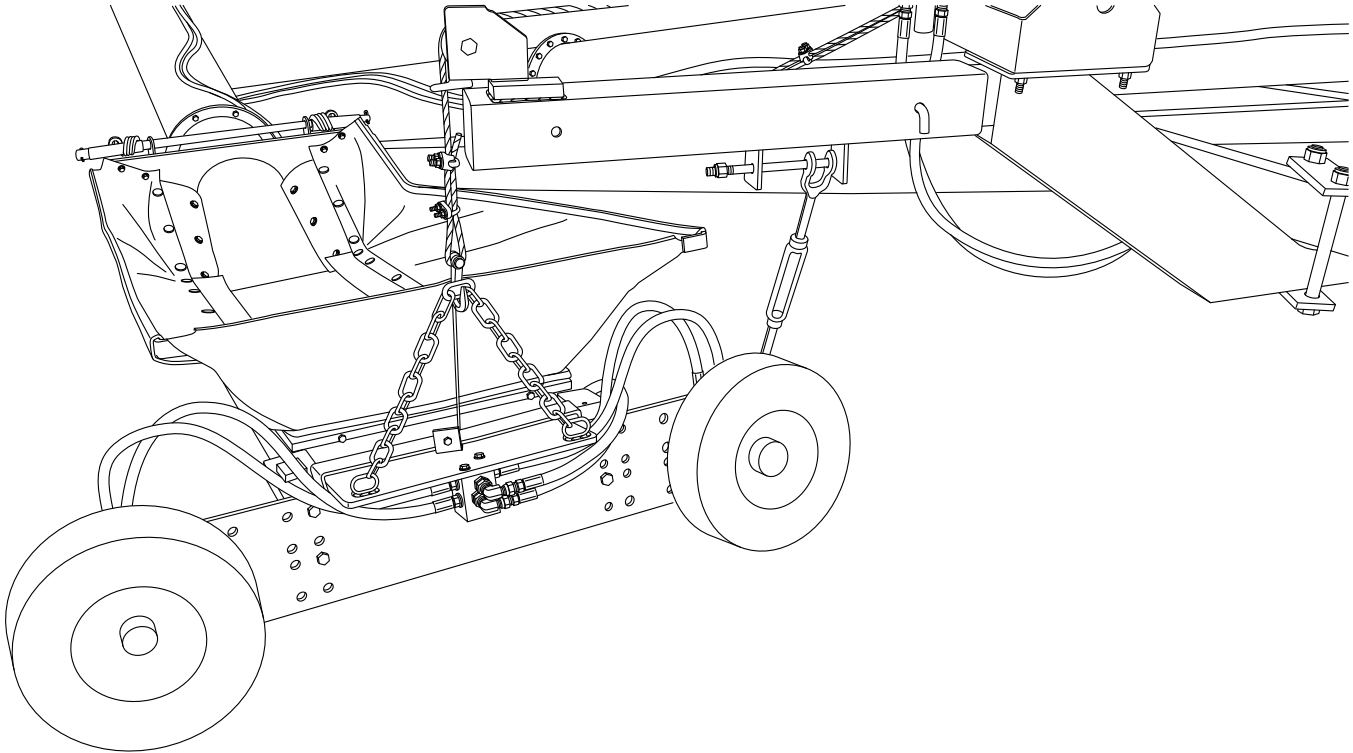
**Figure 14. Hopper in Transport Position**

## 5.8. Hydraulic Power Swing Operation

---

➡ The Hydraulic Power Swing is an optional component for some conveyor models.

1. Connect the hydraulic hoses to the power source.
2. Use the valve handle to move the Swing Away Transfer to the desired position.

**Note**

When adjusting the power swing, it is normal to hear high pitched sounds depending on the power source. This sound is caused by a safety device which restricts hydraulic oil flow and prevents the power swing from moving too quickly.

Figure 15. Power Swing Control Valve



## 5.9. Electric Power Swing Operation

➡ The Electric Power Swing is an optional component for some conveyor models.

Remote transmitters are pre-programmed from the factory — to reprogram your remote (or to add additional remotes), please see the Appendix.

You can register more than one remote transmitter to a single Power Swing. However, it is not recommended to register one remote transmitter to multiple Power Swings.

Figure 16. Power Swing Remote Transmitter

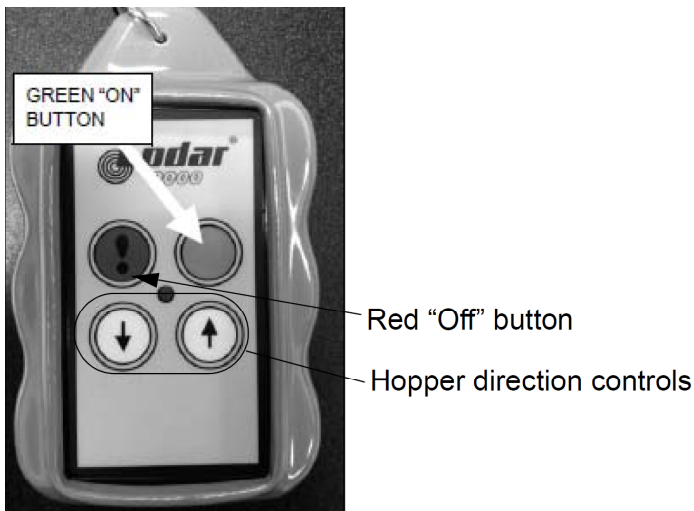

1. Connect the positive wire directly to the positive terminal on the tractor battery and the negative wire to the tractor chassis (see [Figure 17](#)). The negative terminal on the tractor battery should also be grounded to the chassis. There are 5/16" lugged terminals supplied with the kit.

**Figure 17. Electrical Cables**

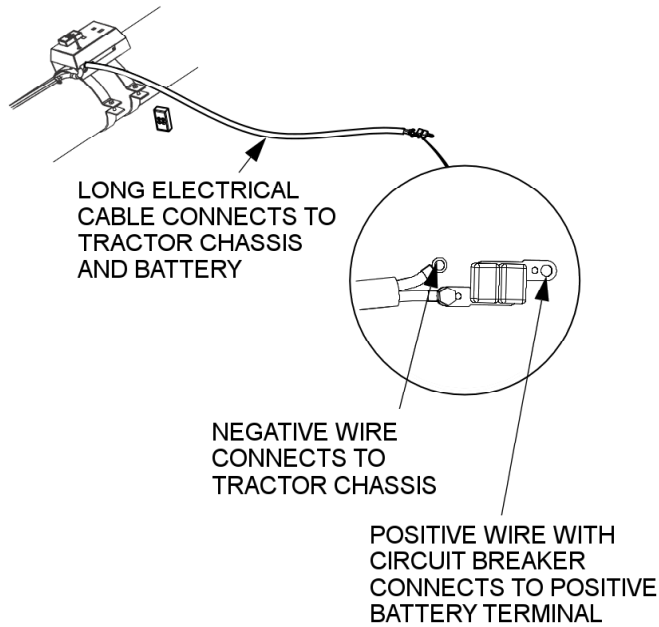

**NOTICE** If these electrical cables are not hooked up properly the electric controller will be damaged.

**Important**

If the Electric Power Swing will need to be moved from one tractor to another on a regular basis, 200 Amp booster-style cable clamps can be installed at the owner’s own risk and expense.

2. On the high end of the Power Swing remote receiver box, flip the power switch ([Figure 18](#)) to the ON position.

**Table 5. Power Swing Receiver Box**

Item	Description
1	Receiver Box
2	Power Switch
3	Direction switch

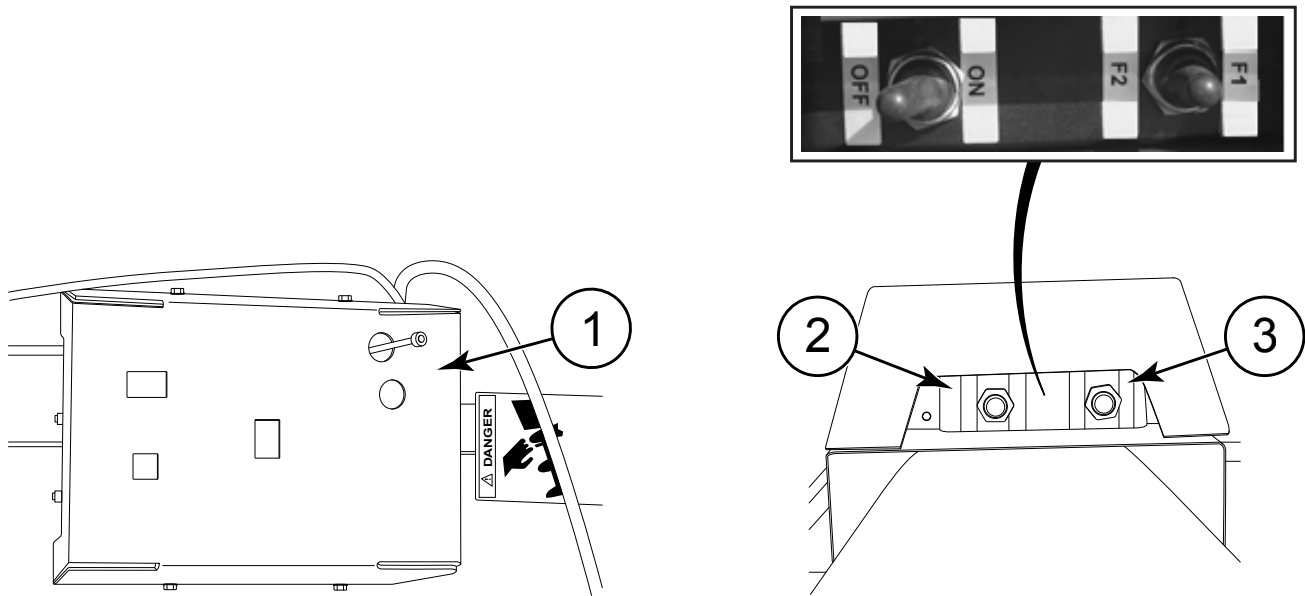
**Figure 18. Power Swing Receiver Box****For Receiver Box Operation:**

1. Using the direction switch, move the switch in the desired direction of travel (either F1 or F2).
2. Once finished moving the hopper, release the switch to stop operation (it should return to the neutral position).

**For Remote Transmitter Operation:**

1. Push the green button (no symbol) to turn the remote ON (Figure 16).
2. Push the yellow directional buttons (marked with arrows) located below the ON/OFF buttons in the direction you want the hopper to move (Figure 16).
3. If this does not work:
  - a. Push the red button (with an exclamation mark) to turn the remote OFF.
  - b. Then push the green button (no symbol) to turn the remote back ON.
4. Operate the remote as outlined above, using the two yellow directional buttons (marked with arrows) located at the bottom of the remote to move the hopper as desired.

## 5.10. Collapsible Hopper Cloth Control

The conveyor is designed with a collapsible hopper cloth to allow it to go under low discharge units.

Move the control handle toward the hopper or intake to raise the hopper cloth, and move the handle toward the outlet or spout end to collapse the hopper cloth.

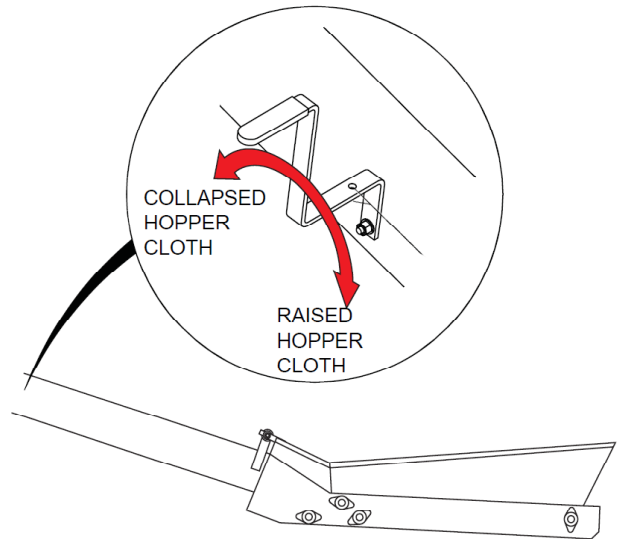

## 5.11. Conveyor Operating Angles

Some grains can be moved at steeper angles than others. Grain will roll back if the conveyor is positioned at an angle greater than the grains natural moving/piling angle (angle of repose). The following table indicates the maximum angle that different grain types can be moved.

To determine conveyor angle, use the angle guide decal on your conveyor.

**Note**

The lower the angle, the greater the capacity of the conveyor.

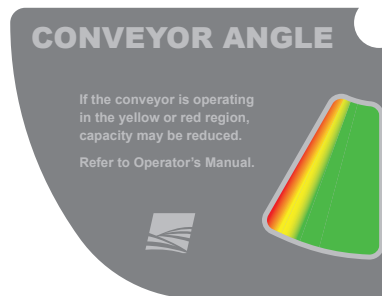

**Table 6. Maximum Moving Angles for Grains**

Grain	Maximum Conveyor Angle (degrees)	Grain	Maximum Conveyor Angle (degrees)
Flax	24	Wheat	26
Lentils	29	Alfalfa Pellets	34
Mustard	26	Barley	25
Canola	20	Canary Seed	26
Oats	28	Chickpeas	30

**Table 6 Maximum Moving Angles for Grains (continued)**

<b>Grain</b>	<b>Maximum Conveyor Angle (degrees)</b>	<b>Grain</b>	<b>Maximum Conveyor Angle (degrees)</b>
Peas	30	Corn	23
Rice	36	Shelled Corn (dry)	23
Rye	25	Shelled Corn (wet)	28
Soybeans	28	Cotton Seed	30-45
Sunflower	22	Durum	23
Triticale	23		

# 6. Operation



Before continuing, ensure you have completely read and understood this manual's Safety section, in addition to the safety information in the section(s) below.

## 6.1. Operation Safety

---

### WARNING

- Keep away from rotating and moving parts, including the conveyor belt, drive components, shafts, and bearings.
- Do not enter the grain bin or truck while the conveyor is operating.
- Always operate with guards, covers, and shields in place.
- Have another trained person nearby who can shut down the equipment in case of accident.
- Keep the work area clear of bystanders.
- Keep the work area clean and free of debris.
- Ensure maintenance has been performed and is up to date.



Refer to your bin operation manual for specific operating and safety information for your bin.

## 6.2. Start-up and Break-in

---

Check the following during the first hours of operation.

1. Check that the conveyor intake and discharge areas are free of obstructions.
2. Check conveyor belt alignment to ensure preset alignment does not vary under loaded conditions. See Maintenance Section for alignment instructions.
3. Check the conveyor belt tension. See Maintenance Section for tension instructions.
4. Check the pinch roller bearings on the s-drive pinch roller are not tight.
5. Visually inspect the conveyor, see Visual Inspection in Maintenance Section.
6. Check tightness of all bolts/nuts, fasteners, and hardware (re-torque if necessary).
7. Ensure adequate power is supplied to operate the conveyor, see [Section 9. – Specifications on page 69](#).
8. Start the tractor and idle at low rpm. Slowly engage the PTO drive. Refer to PTO Drive Operation.
9. Start the hydraulic drive on the Swing Away transfer conveyor. Refer to Hydraulic Drive Operation.
10. Gradually begin feeding grain into the hopper, bringing the tractor PTO drive to roughly half speed. Do not overfeed the hopper on initial loads; keep the feed of grain at about half capacity.
11. Be aware of unusual sounds. If any are heard, determine the source and stop the conveyor. Lock out the power and correct the problem before resuming work. If you are unsure of the problem or procedure, contact your local dealer.
12. After the conveyor runs fairly smoothly, proceed to unload at the specified full PTO speed. Do not exceed the specified full PTO speed (see [Section 9. – Specifications on page 69](#)).
13. Do not run the conveyor for long periods of time without material on the conveyor belt because it increases wear. Try to run only when moving material.

14. Stop the conveyor when it is empty of grain, lower fully and lockout power.

**Important**

After the initial start-up and inspection, the conveyor should be shut down and visually inspected (see Maintenance Section) after approximately ten hours of operation.

## 6.3. Operation - Swing Away Transfer Hydraulic Motor Drive

1. Set the hydraulic valve so that is open as shown in [Figure 19 on page 46](#).
2. Place all tractor controls in neutral.
3. Start the tractor and run at low idle.
4. Engage the tractor hydraulic control lever and increase the engine to desired speed.

**Note**

The correct operation of a hydraulic system is directly linked to the pump's ability to supply the correct oil flow and pressure. If you cannot obtain the correct belt speed, check with the dealer to ensure the power unit is delivering the correct oil volume and pressure.

5. Run until the belting is empty.
6. Reduce tractor engine speed to low idle.
7. Place hydraulic control lever in neutral.
8. Shut off engine and remove ignition key.
9. Set the hydraulic valve so that it is closed.

**Hydraulic Valve**

The hydraulic valve can be set to control the flow of oil to the hydraulic motor. This valve should normally be set fully open to operate or fully closed when not operating. The valve handle can be used to set partial speeds, however this is not recommended for extended periods.

**Figure 19. Hydraulic Drive Valve**

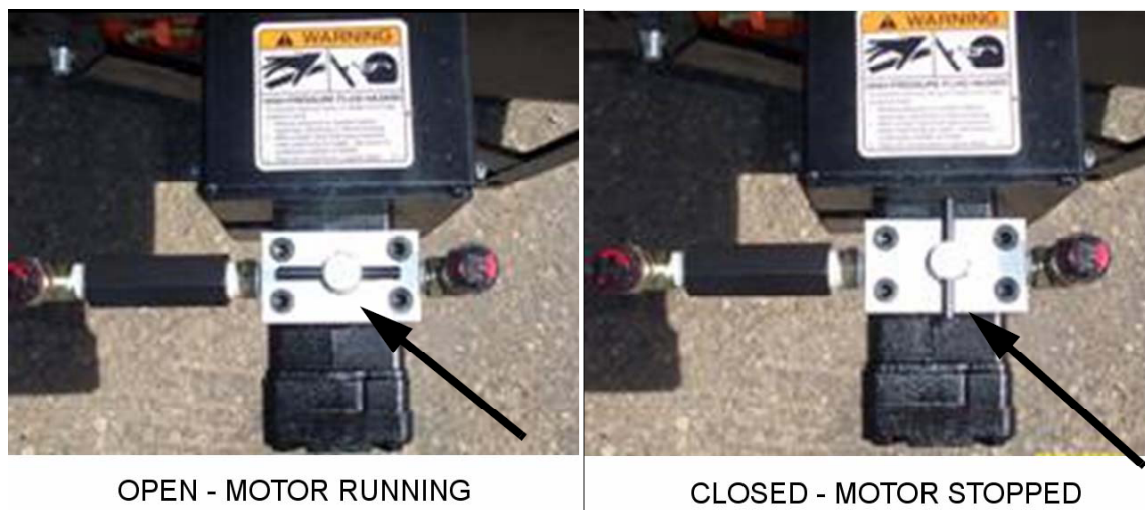

## 6.4. Operation - PTO Drive

---

1. Attach the PTO driveline securely to the tractor and confirm the connection to the conveyor shaft is secure.
2. Confirm the PTO driveline rotating shield and other shields/guards are in place and in good working order.
3. Align the tractor axis with the conveyor input shaft to minimize the angles of the universal joints on the PTO driveline.

### **Important**

Check that the PTO does not exceed the maximum operating angle, refer to [Section 9. – Specifications on page 69](#).

4. Confirm that the conveyor-to-tractor PTO hookup distances are set as required.
5. Ensure the PTO drive on the tractor is in the off position before starting the tractor.
6. Start tractor engine at low idle, slowly engage the PTO with the tractor idling to prevent unneeded stress on the drive components and shear bolts.
7. If everything is operating normally, start running grain through the conveyor and increase the tractor PTO to the specified full speed to produce the required flow.
8. To shut down, reduce the speed to low idle and lock out the PTO.
9. Disconnect the PTO driveline from the tractor and secure it to the PTO transport saddle with the safety chain and keep it in transport saddle when transporting.

### **When raising or lowering the conveyor:**

Disconnect the PTO driveline.

### **When starting under load:**

If restarting the conveyor under load (tube is full), engage the PTO with the tractor idling.

### **NOTICE**

Engaging the PTO at high engine speed under load will result in equipment damage.

### **Shear Bolts:**

If a shear bolt in the PTO driveline fails, shut down and lock out the tractor to replace the shear bolt. Ensure that the shear point is through the shank of the bolt, not the threads. Refer to [Section 9. – Specifications on page 69](#) for shear bolt sizes.

## 6.5. Loading Area

---

To achieve maximum capacity, feed material on the belt:

- until the material tube clearance is 1/2".
- in the same direction as the belt travels.

Do not flood feed the hopper.

## 6.6. Conveyor Belt Speed

---

The best results are obtained when the conveyor belt speed is set at 600 to 700 ft/min on the 1500 series, and 600 to 650 ft/min on the 1800, 2000, and 2400 Series.

Count the number of belt revolutions per minute to determine belt speed. See [Section 9. – Specifications on page 69](#) for belt length.

**Note**

Use the connector splice as a reference when counting belt revolutions.

To calculate, for example, 600ft/min belt speed for a 47ft belt:

$$\frac{BeltSpeed}{BeltLength} = \frac{600}{47} = 12.76$$

Therefore, 12.76 or approximately 13 belt passes per minute will provide a 600ft/min belt speed.

## 6.7. Emergency Shutdown

---

In an emergency situation:

1. Stop or shut down the power source immediately and lock out all power.
2. Stop the flow of material (if applicable).
3. Ensure the machine components come to a stop before inspecting.
4. Correct the emergency situation before resuming work.

## 6.8. Restarting with a Full Tube

---

When the conveyor is shut down inadvertently or due to an emergency, the tube may still be filled with grain.

1. With the power source locked out, remove as much of the grain as possible from the tube and intake using a shop vacuum or other tool. Do not use your hands.

**NOTICE**

Starting under load may result in damage to the conveyor.

2. If guards or covers have been opened or removed, close or replace them before restarting the unit.
- ➔ 3. **Electric and Gas Drive Models:** It may be necessary to tighten the drive belts slightly to handle the heavier than normal loads.
- ➔ 4. **Gas and PTO Drive Models:** Since the start-up torque loads are so much higher than normal when the conveyor belting is full, restart at low speed. Do not let the conveyor belt drive roller spin on the belt if conveying belt does not start moving immediately. This will damage the drive roller and conveying belt.
5. Once the conveyor has been started, you may resume normal operation.

## 6.9. Shutdown

---

When operation has been completed:

1. Once the conveyor is clear of grain, lock out the power source.
2. Lower the conveyor fully.
3. Clean out any remaining grain from the conveyor with a vacuum or sweep out.
4. Clean the entire work area.
5. Remove anchors, supports, and chocks.

## 6.10. Clean Out

---

After using your conveyor, follow the clean out steps below to ensure longer belt life and trouble free operation. Failure to clean out the conveyor can cause build up of product on the belt and roller shafts, causing spillage, roller misalignment, and excess wear/damage to the belt.

 **WARNING** Failure to lock out power can cause severe injury.

1. Remove any product remaining in the hopper and spout with a vacuum or sweep out.
2. Remove debris from shafts, sheaves, and drive belts (as equipped).
3. Once the conveyor is empty of all product, check for damage on belt and lacing such as notches or cut outs. Any damage on belt may result in product getting under it creating a build-up. If belt replacement and re-lacing is necessary, refer to the Maintenance Section.

### **Important**

Ensure the conveyor is free from all product and debris to prevent build-up. Any build-up on belt and shaft becomes a source of spillage and can cause belt misalignment with the possibility of belt edges sustaining damage on the fixed structure. Build-up on the hopper and spout will cause the belt to wear faster due to drag.

4. Once cleaned out, cover intake to prevent moisture from collecting in hopper.

## 6.11. Conveying Fertilizer

---

Fertilizer may be conveyed using the conveyor when operated at a reduced capacity and additional care is taken to thoroughly clean the conveyor after operation.

### **Important**

Fertilizer weakens the belt lacing and warranty is void on all lacing used with fertilizer. The belt lacing may need to be replaced more often if you convey fertilizer.

### **Additional Operating Requirements**

To prevent problems that can be caused by conveying fertilizer:

1. Do not allow fertilizer to fill over the edge of the belt. This will allow fertilizer to get under the belt and start building up.
2. Reduce the flow if the conveyor belt starts to slip. Denser fertilizers will slow the conveyor belt down due to the weight of the product. Too much material will cause the drive roller to slip and lead to additional wear on the roller.
3. Do not move fertilizer with your conveyor in humid, wet or rainy conditions. This will cause buildup of fertilizer under your conveyor belt.

### **Additional Clean-Out Procedures**

Proper cleaning will help to ensure longer belt life and prevent excess rust formation.

1. Run conveyor empty at full speed for 5-10 minutes after conveying fertilizer. This will help ensure that any product that may be under the belt will be cleaned out and prevent build up.

 **WARNING** Do not attempt to manually remove build-up while conveyor is running.

2. Next, run the belt at low idle and inspect for damage on the belt and lacing, such as notches or cut outs caused by mice and normal wear. Any damage on the belt may result in fertilizer getting under the belt

creating a buildup. Consider replacing the conveyor belt if it is in poor condition. If equipped with an electric motor, inspect on the belt return side with the electric motor not running. Turn on the conveyor to expose the belt that was previously in the tube. Turn off the conveyor and inspect the belt on the belt return, along with the lacing.

3. Shutdown and lockout power to the conveyor and vacuum or sweep out any remaining fertilizer from the hopper.
4. Remove the s-drive bottom cover and remove any buildup from this area and clean cover. Replace the cover when complete.
5. If buildup is evident on or under the belt, remove the buildup to ensure proper operation of the conveyor. When necessary remove fertilizer buildup from under the belt by scraping and washing the belt.

**Figure 20. Fertilizer Buildup on Rollers**



**Figure 21. Fertilizer Buildup at Hopper Transition**

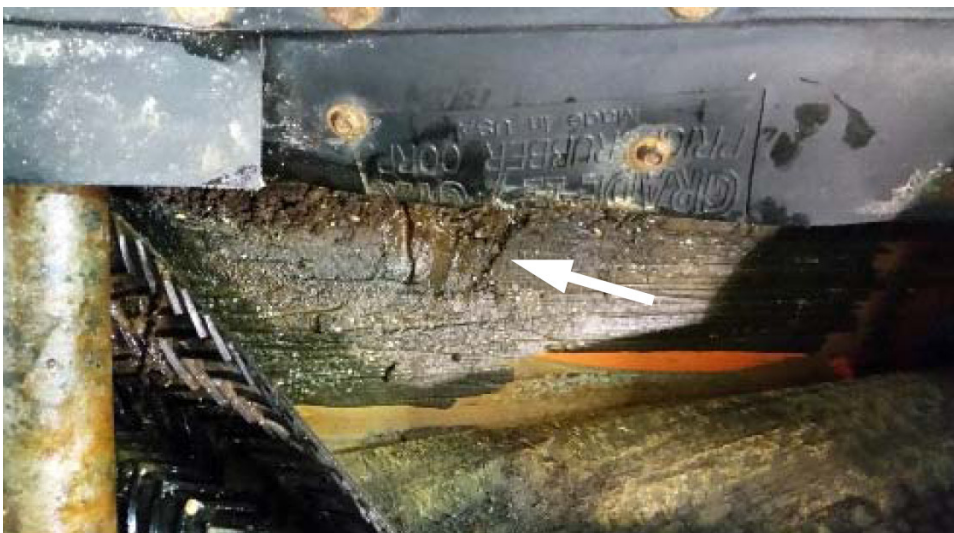

## 6.12. Storage

---

After the season's use, the conveyor should be thoroughly inspected and prepared for storage. Repair or replace any worn or damaged components and perform maintenance as described in the Maintenance Section to prevent any unnecessary downtime at the start of the next season.

To ensure a long, trouble-free life, this procedure should be followed when preparing the unit for storage.

1. Remove all residual material from the hopper and the tube.
2. Stop the machine with the belt lacing inside the tube. This helps prevent the lacing from rusting.
3. Wash the conveyor thoroughly using a water hose or pressure washer to remove all dirt, mud, debris, or residue.
4. Inspect all moving or rotating parts to see if anything has become entangled in them. Remove any entangled material.
5. Touch up all paint nicks and scratches to prevent rusting.
6. Check tire pressure and inflate. For inflation pressure, refer to [Section 9. – Specifications on page 69](#).
7. Inspect the conveyor for cracks, tightness of fittings and fasteners, hydraulic hose cracks (if applicable). Have required repairs performed to replace worn or damaged components.
8. Store in an area that is dry, level, free of debris, and away from human activity. Store inside if possible.
9. Chock wheels.
10. Support intake on blocks to eliminate prolonged contact with the ground.
11. Clean and lightly lubricate the spline on the PTO driveline. Cover the PTO driveline with a plastic bag to protect it from the weather and place it in the transport saddle.
12. Lower the conveyor fully for storage.
13. Place the swing-away hopper in transport position, ensuring there will be adequate drainage of any moisture.

# 7. Maintenance

 Before continuing, ensure you have completely read and understood this manual’s Safety section, in addition to the safety information in the section(s) below.

## 7.1. Maintenance Safety

**WARNING**

- Keep components in good condition. Follow the maintenance procedures.
- Ensure the service area is clean, dry, and has sufficient lighting.
- Do not modify any components without written authorization from the manufacturer. Modification can be dangerous and result in serious injuries.
- Shut down and lock out power before maintaining equipment.
- After maintenance is complete, replace all guards, service doors, and/or covers.
- Use only genuine AGI replacement parts or equivalent. Use of unauthorized parts will void warranty. If in doubt, contact AGI or your local dealer.



**Before attempting maintenance of any kind:**

- Lower the conveyor fully.
- Chock wheels.
- Support tube if performing maintenance on the undercarriage assembly.
- **If equipped with hydraulics:** Before applying pressure to a hydraulic system, make sure all components are tight and that hoses and couplings are in good condition.

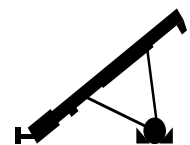

## 7.2. Maintenance Schedule

Proper maintenance habits mean a longer life, better efficiency, and safer operation. Please follow the Maintenance Schedule below. Keep good records of the hours the conveyor has been operated and the maintenance performed.

<b>Daily:</b>
<a href="#">Section 7.3 – Visually Inspect the Equipment on page 53</a>
<a href="#">Section 7.4 – Lubricate the Equipment on page 54</a>
<b>Monthly:</b>
<a href="#">Section 7.8 – Inspect Hydraulic Hoses and Fittings on page 56</a>

Section 7.9 – Inspect the Hopper Flashing on page 56
Section 7.10 – Check the Roller Bearings on page 56
Section 7.11 – Check the Rollers on page 56
Section 7.14 – Inspect Belt Lacing on page 60
Section 7.6 – Check the Gearbox Oil on page 55
<b>Annually:</b>
Section 7.5 – Oil the Chain Coupler on page 54
Section 7.12 – Tension the Conveyor Belt on page 56
Section 7.13 – Align the Conveyor Belt on page 58
Section 7.17 – Clean and Wash the Equipment on page 62
<b>2–3 Years:</b>
Section 7.15 – Replace the Belt Lacing on page 61
Section 7.7 – Change the Gearbox Oil on page 55
Section 7.20 – Inspect and Service the Hydraulic Winch and Lift Cable on page 65
<b>As Required:</b>
Section 7.18 – Repack the Wheel Bearings with Grease on page 63
Section 7.19 – Check/Adjust the Truss Cables on page 63
Section 7.16 – Replace the Conveyor Belt on page 61

## 7.3. Visually Inspect the Equipment

 **WARNING** Lock out power before inspecting.

Check the following during a visual inspection:

1. Ensure all guards are in place and in good working order.
2. Examine the conveyor for damage or unusual wear.
3. Check tightness of bolts/nuts, fasteners, and hardware (re-torque if necessary).
4. Be sure all safety decals are in place and are legible.
5. Check that the discharge and intake area are free of obstructions.
6. Inspect all moving or rotating parts to see if anything has become entangled in them. Remove any entangled material.
-  7. **When equipped:** Inspect hydraulic hoses and fittings for leaks and wear. Fix or replace where necessary.
8. Check wheel bolts are tight and examine tires for gashes, uneven wear, or loss of air pressure. See [Section 9 – Specifications on page 69](#) for recommended tire pressure and torque information.
9. Check all operating, lifting, and transport components. Replace damaged or worn parts before using the conveyor.

- ➔ 10. **PTO Models:** Check the PTO shield & replace if damaged.
- ➔ 11. **If equipped with truss cables:** Inspect the truss cables for proper tension and possible damage such as fraying, kinking, or unwinding.
- ➔ 12. **If equipped with a hand or hydraulic winch:** Inspect winch cable for fraying, kinking, unwinding, or other possible damage.

## 7.4. Lubricate the Equipment

---

Your equipment can operate at top efficiency only if clean fluids and lubricants are used. Use clean containers to handle all fluids and lubricants. Store them in an area protected from dust, moisture, and other contaminants.

1. Wipe the grease fittings with a clean cloth before greasing to avoid injecting dirt and grit.
2. Use a hand-held grease gun for all greasing.
3. If fittings will not take grease, remove and clean thoroughly.
4. Replace fittings if they are broken or will not accept grease.
5. If Intake Bushing is present in your auger, lubricate it.

Use SAE multi-purpose high-temperature grease with extreme pressure (EP) performance. SAE multi-purpose lithium-based grease is also acceptable.

### 7.4.1 PTO Driveline

Figure 22. Typical PTO Driveline Grease Points

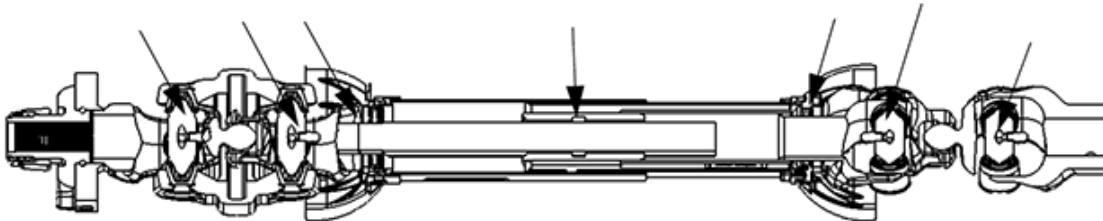
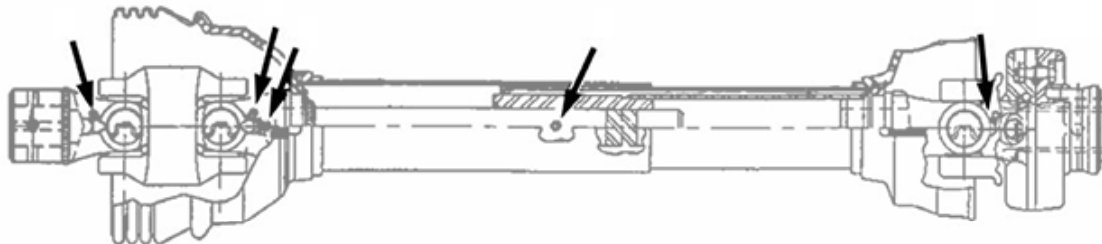

Figure 23. Typical PTO Driveline Grease Points



## 7.5. Oil the Chain Coupler

---

The chain coupler is located between the hydraulic motor and the conveyor's drive roller.

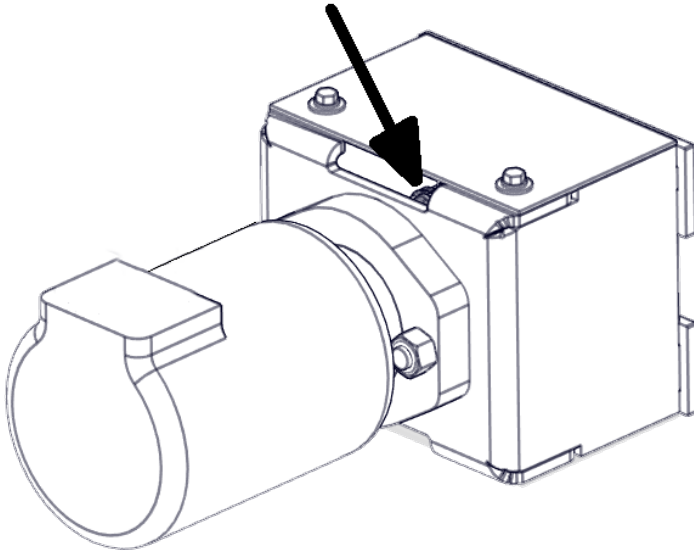
**Figure 24. Chain Coupler Location**

## 7.6. Check the Gearbox Oil

---

1. Remove fill/vent plug to check gearbox oil level. Insert an improvised dipstick (rolled paper or plastic tie) into the oil filler hole to determine the oil level.
2. Note the level and the condition of the oil. Maintain oil level at half full (center of cross shaft) with 90W or equivalent gear oil, adding as necessary or drain and refill if condition is poor.
3. Ensure gearbox is level when checking or refilling.
4. Do not overfill when adding oil.
5. Replace fill/vent plug.

## 7.7. Change the Gearbox Oil

---

Use SAE approved 90W or equivalent gear oil.

1. Remove gearbox from the conveyor.
2. Place a pan under the drain plug.
3. Use a wrench and remove the drain plug.
4. Loosen the filler plug so air can enter the gearbox and the oil will drain freely.
5. Allow the oil to drain completely.
6. Replace the drain plug.
7. Add oil until the gearbox is half full (center of cross shaft) and replace filler plug. A flexible funnel may be required. Gearbox should be level when checking or refilling. **Do not overfill.**
8. Reinstall the gearbox and guards.

## 7.8. Inspect Hydraulic Hoses and Fittings

---

➡ When equipped:

1. Pressurize the system.
2. Using a piece of cardboard or wood, run it along the length of the hose and around all fittings.
 

**⚠ WARNING**

 Escaping hydraulic fluid under pressure will cause serious injury if it penetrates the skin surface.
3. Replace the hose or tighten/replace the fitting if a leak is found. For replacement hoses, refer to [Section 9. – Specifications on page 69](#).
4. Replace any hose that is badly cut, nicked, abraded, or is separating from the crimped end of the fitting.
5. Secure hoses to the machine.

## 7.9. Inspect the Hopper Flashing

---

Check hopper flashing for wear and replace any that are worn. Worn flashing will cause hopper leakage.

## 7.10. Check the Roller Bearings

---

Check the roller bearings for wear. Any rollers making noise, getting hot while running, or that give should be replaced.

## 7.11. Check the Rollers

---

Inspect the roller to see if it is showing signs of wear. Replace rollers that are worn.

**NOTICE** Operating the conveyor with a damaged roller will result in a damaged conveyor belt.

## 7.12. Tension the Conveyor Belt

---

Adjusting your conveyor belt for proper tension helps to ensure trouble-free operation and long belt life.

The conveyor belt only needs to be tight enough to not slip on the drive roller. If the belt is too loose, it will slip on the drive roller making a noticeable sound, slowing the belt down.

The conveyor belt should not be easy to pull from the hopper transition sides, otherwise the belt will require tensioning.

**NOTICE** Failure to stop using the conveyor with a slipping belt will damage it and/or the drive roller. In extreme cases, sections of burnt belt will have to be replaced. This type of damage is not covered by warranty.

### To set correct conveyor belt tension:

1. While the conveyor is running empty, fully tighten the nut against the pretensioner (take-up pipe) so that the edge of the indicator pipe is within the green area, see [Figure 25 on page 57](#).

2. Ensure the take-up roller is tensioned equally by using a tape measure to check the distance “X” on both sides.
3. After the conveyor belt has been tensioned, check the alignment of all s-drive rollers, see [Section 7.13 – Align the Conveyor Belt on page 58](#).
4. If the belt is still loose after tensioning, the belt needs to be shortened or replaced (depending on wear).

**Figure 25. S-Drive**

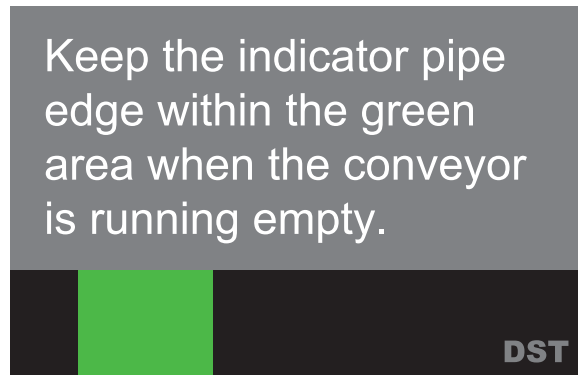
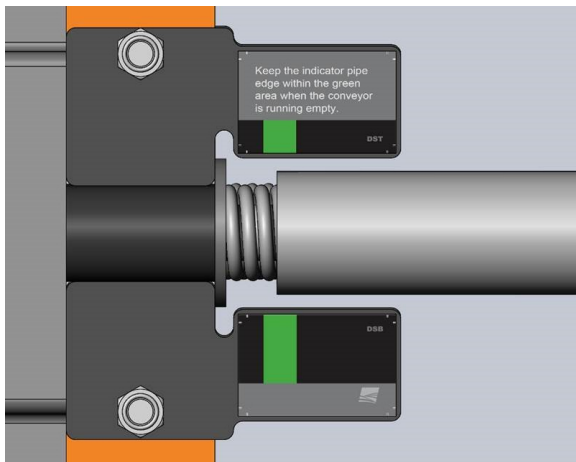
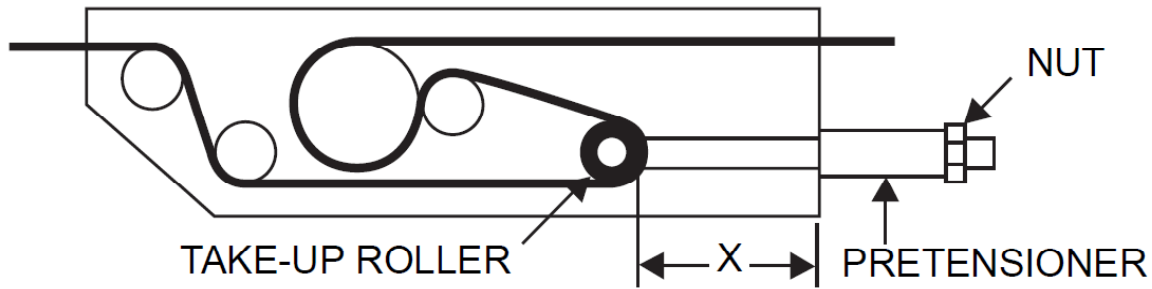

### 7.12.1 S-Drive Pinch Roller

The s-drive pinch roller should always be set with its flange nuts wiggle loose, allowing the spring to push against and pinch the conveyor belt. This should not normally require adjustment.

1. Do not tighten bearing nuts, these must remain wiggle loose.
2. Tighten pinch spring, if loose.
3. Confirm that the pinch roller and drive roller are flush.

Figure 26. S-Drive Pinch Roller

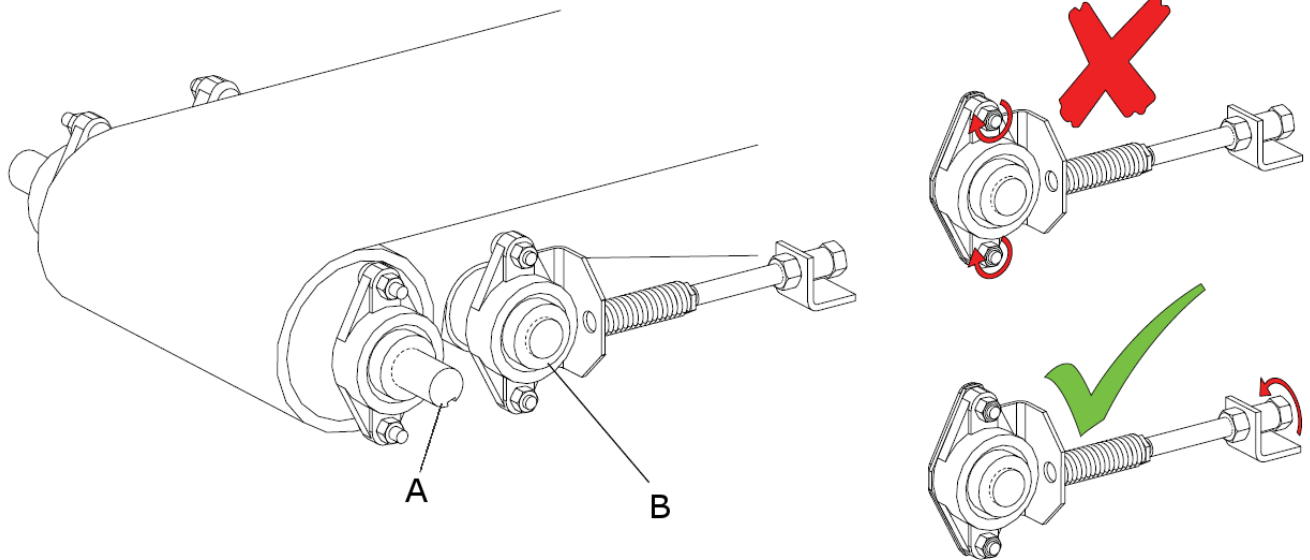

- A — Drive Roller
- B — Pinch Roller

### 7.13. Align the Conveyor Belt

#### Basic Conveyor Belt Alignment:

The conveyor belt will run straight when all of the rollers are straight.

Loosen or tighten the adjustment bolt(s) to align the conveyor belt. Tighten the side the belt has moved toward, or loosen the side the belt has moved away from.

Figure 27. Roller out of Alignment

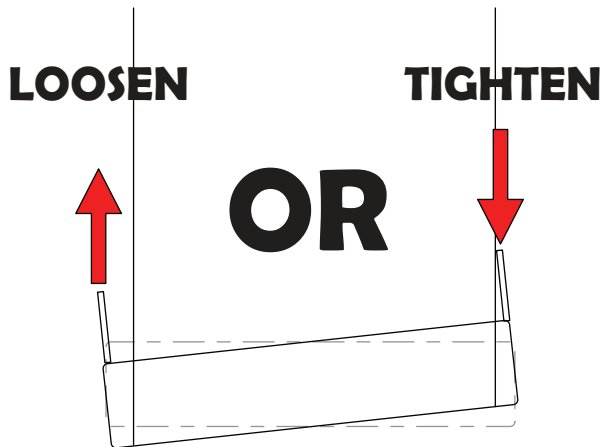

**Before Aligning the Belt:**

- The conveyor must be empty of all grain.
- Wait until the belt makes a complete revolution before adjusting the rollers. Some belts may have uneven edges, appearing misaligned.

**To Align the Belt:**

If your belt is tracking off-center, follow the sections and steps in the order following to center it.

**Figure 28. Belt Tracking to One Side**

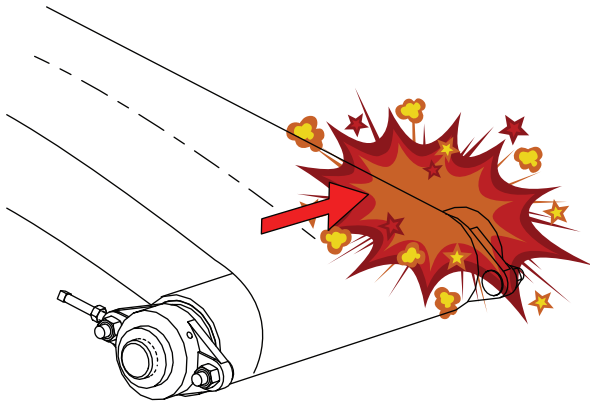

### 7.13.1 Adjust the Rollers

1. Loosen bearing nuts and jam nuts (if equipped).

**Figure 29. Loosen the Bearing Nuts**

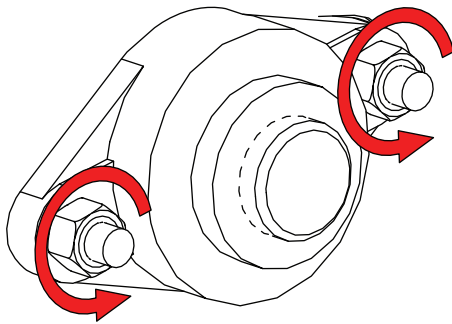

2. Rotate adjustment bolt 1/2 turn.

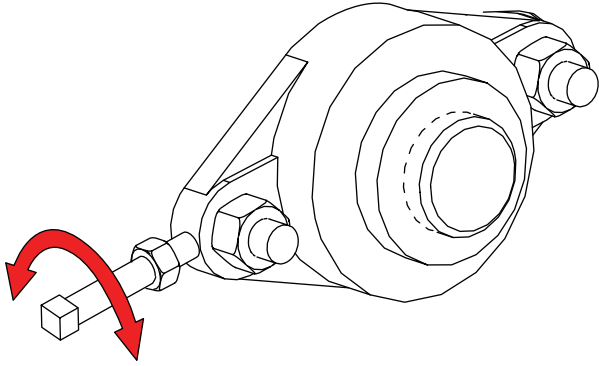
**Figure 30. Rotate the Adjustment Bolt**

3. Restart conveyor and run empty for 1 minute.
4. Stop the conveyor and remove ignition key or lock out the power source.
5. If the belt has centered, move to next step. If not, repeat Step 2 to Step 4 until the belt is centered.
6. Tighten the bearing bolts and jam nut (if equipped).
7. Replace any guards that were removed.

### 7.13.2 Adjust the Belt Return Wear Blocks

1. Adjust the wear blocks by rotating them 90 or 180 degrees. If they are worn down, replace the wear blocks.

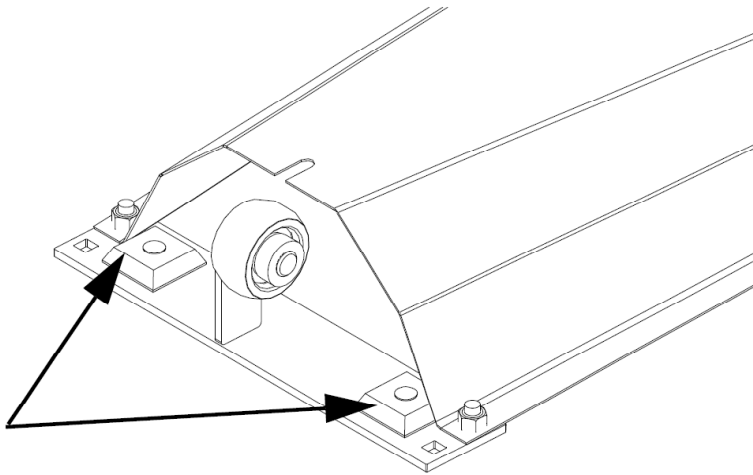
**Figure 31. Belt Return Wear Blocks**

2. Replace the guards if removed.

## 7.14. Inspect Belt Lacing

Inspect the condition of the belt lacing, if any clips are worn through, replace all lacing.

## 7.15. Replace the Belt Lacing

---

1. Rotate the conveyor belt until the lacing is between the s-drive and the hopper.
2. Loosen the tension on the s-drive take-up roller all the way.
3. Remove the lacing retainer clip and pin.
4. Using a square and sharp knife, cut the lacing off right behind the lacing clips. The cut belt **MUST** have a square end.
5. Use a knife to cut Chevron pattern off 1” back from the end of the belt. This ensures that the lacing is centered and fully seated on the belt.
6. Count the lacing clips on the removed section and install the same number of new lacing clips with a lacing tool. Center the lacing on the belt and follow the lacing tool’s instructions.
7. Align the conveyor belt ends and install the lacing pin.
8. Crimp the retainer clips onto each end of the lacing pin. Refer to .
9. Tighten the conveyor belt. Refer to .
10. Seal the belt lacing (if the conveyor is used to handle oilseed). Refer to
11. Check and set the belt alignment. Refer to [Section 7.13 – Align the Conveyor Belt on page 58](#).
12. Engage the conveyor drive. Allow the conveyor to run for 30 seconds, then shut down the conveyor and inspect the lacing.

## 7.16. Replace the Conveyor Belt

---

1. Rotate the conveyor belt until the lacing is by the hopper or is easily accessible.
2. Move the tension roller to its loosest position.
3. Pull all the slack to the lacing area.
4. Remove the lacing retainer clip and pin.
5. Attach one end of the replacement belt to the belt end being removed, closest to the hopper.
6. Pull the old belt out and the new belt will be threaded into place.
7. Disconnect the old belt.
8. Reattach conveyor belt ends together. If required, use a ratchet strap clamped to both ends of belt to cinch belting ends together. [Figure 32 on page 62](#).

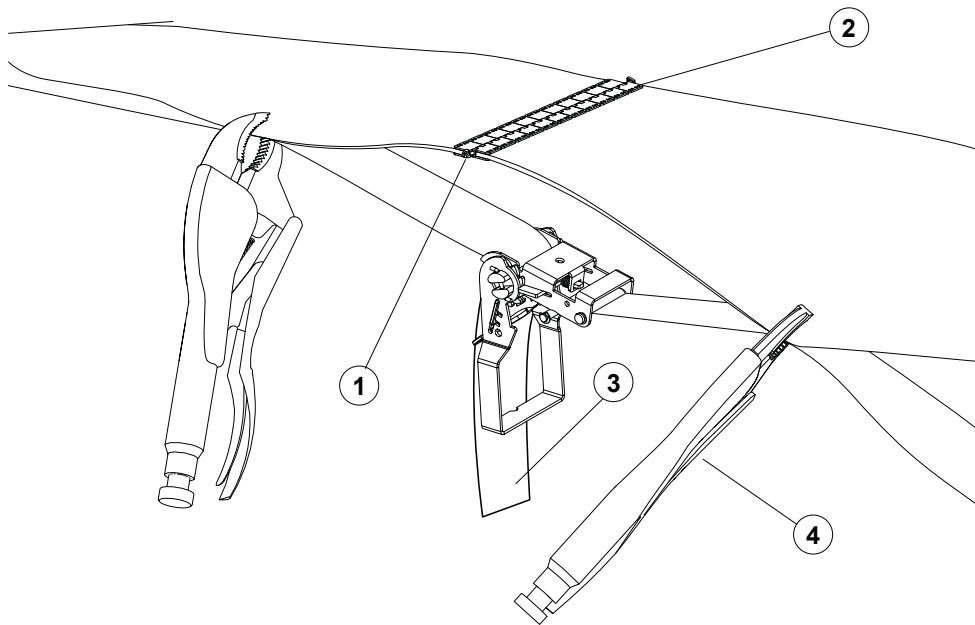
**Figure 32. Using the Ratchet Strap**

9. Install the lacing pin and crimp the retainer clips onto each end of the lacing pin, see [Figure 33](#).
10. Remove the ratchet strap and tighten the conveyor belt (see “Tension the Conveyor Belt”).
11. Check and set the belt alignment (see “Align the Conveyor Belt”).
12. Engage the conveyor drive. Allow it to run for 30 seconds, then shut down the conveyor and inspect the lacing.

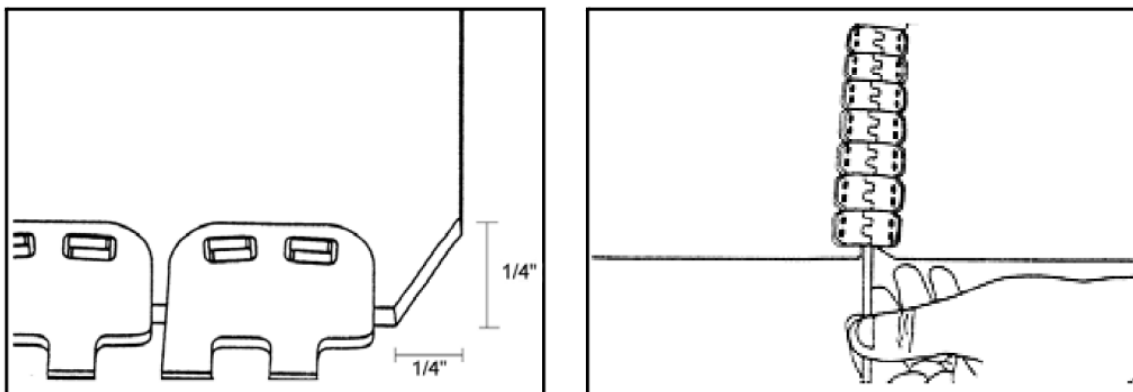
**Figure 33. Lacing the Conveyor Belt**

## 7.17. Clean and Wash the Equipment

1. Clean out excess grain from all areas of the conveyor.

2. Make sure water can drain from the conveyor tube and intake, then wash the tube with a water hose or pressure washer until all dirt, mud, debris, or residue is gone.

**Important**

Do not contact electronic controls with high pressure washer.

3. Provide sufficient time for the water to drain from the conveyor.

## 7.18. Repack the Wheel Bearings with Grease

1. Block wheels and ensure unit is stable.
2. Remove the wheel bolts and the wheels.
3. Clean wheel and hub mounting surfaces to ensure there is no rust or debris.
4. Remove the wheel bearing and pack with grease. Use SAE multi-purpose high-temperature grease with extreme pressure (EP) performance. SAE multi-purpose lithium-based grease is also acceptable.
5. Tighten the wheel bolts (diagonal pattern) with a torque wrench to 100 ft-lb ( $\pm 10$  ft-lb) of torque. Inspect to make sure the wheel is sitting flush with the hub.

**Figure 34. Diagonal Pattern for 4-bolt and 6-bolt Tires**

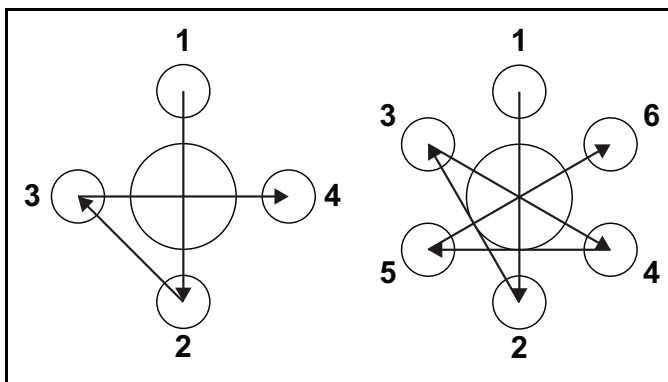

## 7.19. Check/Adjust the Truss Cables

➡ When equipped with Truss Cables:

**Check the Truss Cables:**

Check tube for straightness, no slack in the cables, and a just noticeable upward deflection of the discharge end. During operation, it is normal that for the tube to deflect downward.

**If required, adjust cables by following the procedure below:**

1. Lift the discharge end of the conveyor with a overhead crane, front end loader, or other proper lifting device so that the tube has a slight upward deflection at the discharge to give the cable some slack.



**CAUTION** The lifting device must be capable of supporting approximately half of the weight of the conveyor as provided in the Specifications section.

- ➡
2. When the conveyor has more than one set of cables start from the innermost cables and work your way out.

3. Loosen cable clamps on cable truss where the cable requires adjustment.
4. Locate the eyebolt anchors for the cable. Refer to [Figure 35 on page 65](#).
5. Tighten cable eyebolts evenly on both sides (use eyebolt nuts to tighten eyebolts) until the discharge end just starts to angle upward.
  - The tube should not deflect to the left or right if tightened evenly.
  - Tension should be greater on shorter cables than on longer cables. If the conveyor tubes remain straight then the cables are tensioned properly.
6. If the proper cable tension can't be obtained before the eyebolts run out of adjustment, then do the following:
  - a. Loosen the eyebolts.
  - b. At the eyebolts, loosen the cable clamps, shorten the cables until there is tension on the cable, then tighten the cable clamps fully.
  - c. Return to step 5.
7. Secure jam nut on cable eyebolt and re-tighten any cable clamps that were loosened.
8. The cables are properly tightened when:
  - There is no slack in the cables.
  - The discharge end is deflected slightly upwards.
  - The tube is straight side-to-side.

**Table 7. Truss Cable Adjustment**

Item	Description
1	Cable Clamp
2	Truss Cable
3	Cable Return Bracket
4	Cable Eyebolt
5	Eyebolt Nuts
6	Eyebolt Anchor
7	Cable Truss

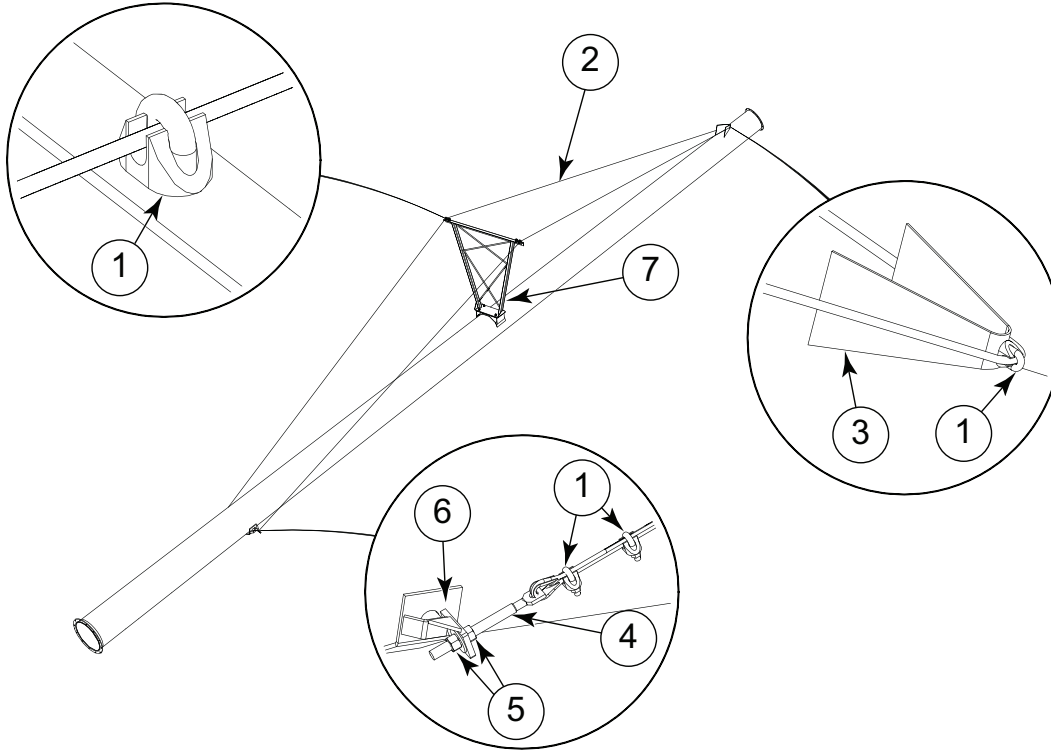
**Figure 35. Typical Cable Truss Assembly**

## 7.20. Inspect and Service the Hydraulic Winch and Lift Cable

**WARNING** Place the conveyor in the fully lowered position with the cable slack.

### To Inspect the Lift Cable:

1. Inspect the cable for damage such as fraying, kinking, or unwinding. Replace if damaged (see below).
2. Check to make sure the cable clamps are secure.
3. Oil the cable pulleys as needed.
4. Occasionally oil the bushings and drum shaft.

### To Replace the Lift Cable:

1. Unwind the winch drum until the cable is slack and remove the cable clamps.
2. Free the cable from the winch and pulleys.
3. Remove the cable clamps that secure the hook in place.
4. Reverse the above steps to install the new cable.

# 8. Troubleshooting

**⚠ WARNING** Shut down and lock out all power sources before diagnosing any of the causes or attempting any of the solutions below.

In the following section, we have listed some causes and solutions to some of the problems you may encounter.

If you encounter a problem that is difficult to solve, even after having read through this section, please contact your local dealer or distributor. Before you contact them, please have this operation manual and the serial number from your machine ready.

## Conveyor

Problem	Cause	Solution
Low conveying capacity.	Conveyor angle is too high.	Re-position with lower tube angle, see Operation.
	Incorrect belt speed.	Verify and adjust belt speed to appropriate speed, see Belt Speed in Operation.
	Conveyor belt slipping.	Tighten conveyor belt, see Conveyor Belt Tension in Maintenance.
Low capacity for some grains.	Smaller and smoother grains will slide at shallower angles.	Reduce conveyor height, see Conveyor Operating Angles in Operation.
Conveyor belt slipping.	Conveying belt loose.	Tighten and align belt, see Belt Tension and Belt Alignment in Maintenance.
	Drive roller worn or damaged.	Replace drive roller, see dealer.
	Belt frozen to tube from operating in high humidity in cold conditions.	Remove conveyor from area of high humidity and warm belt to de-ice.
Excessive conveyor belt edge fraying.	Belt not aligned.	Align belt, see Belt Alignment in Maintenance.
Conveyor belt loose.	Belt stretches over time.	Re-tension belt, see Belt Tension in Maintenance.
		If belt is fully tensioned, you may need to shorten belt and re-lace, see Belt Relacing in Maintenance.
Grain leaking from conveyor hopper.	Belt not aligned (centered).	Align belt, see Belt Alignment in Maintenance.

Problem	Cause	Solution
	Flashing installed incorrectly or worn.	Inspect flashing for wear and replace if required.
	Hopper cloth worn or damaged.	Replace damaged hopper cloth.
	<b>When equipped:</b> Transition filler rings are worn.	Replace transition filler rings.
Hopper cloth collapsing under grain.	Misaligned or broken spring (s).	Check spring installation and repair as required.
	Pivot shafts improperly installed.	On some machines, switching pivot shafts left to right will increase hopper tension.
Grain leaking from conveyor discharge between belt and tube.	Belt not aligned (centered).	Align belt, see Belt Alignment in Maintenance.
Grain leaking from conveyor discharge between hood and belt.	Belt speed is too fast, hood plugging.	Decrease belt speed, see Belt Speed in Operation.
U-clamps or brackets sliding on tube.	U-clamps or brackets not properly crimped to tube.	Contact dealer or AGI to correct positioning.

Drive

Problem	Cause	Solution
Drive making noise.	Hot shaft, pulley or bearing.	Overheated components indicate a failed bearing that must be repaired.
	Broken drive roller.	Replace damaged component.

## Scissor Lift Hydraulics

Problem	Cause	Solution
Valve is leaking.	Loose/cracked fittings.	Tighten/replace fittings.
	Worn hose.	Replace hose.
	Valve spools are worn.	Replace valve.
Machine operates slowly.	Oil is hot.	Check oil level and add if required.
	Blockage in hydraulic lines.	Suction hose blocked or kinked.
	Power source is not producing enough oil volume and/or pressure.	Speed up the engine to produce more flow/pressure The power unit may not have enough capacity to operate properly.
Hydraulic cylinder leaking.	Worn seal.	Replace seal.

# 9. Specifications

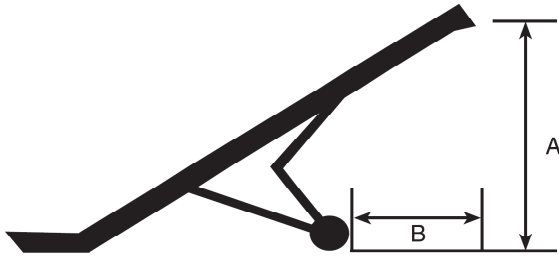

**Table 8. Main Conveyor Specifications**

Model	Belt Length	Weight lbs (Conveyor and Swing Away)	Up - Operation		Down - Transport		Width (ft)	HP PTO	PTO Shear Bolt
			A (ft)	B (ft)	A (ft)	B (ft)			
1565 SA	135'6"	3697	31.4	22.4	11.6	26.1	11	30 HP	HEX BOLT, 5/16-18 GR 8
1575 SA	155'	3952	36.6	30.9	12.6	36.2	11	40 HP	
1585 SA	175'	4434	41.7	35.2	14.2	41.7	11.3	40 HP	
1590 SA	185'	4550	44.2	39.5	14.9	46.7	11.3	50 HP	
15100 SA	205'	5150	49	39.7	13.5	48.3	11.3	50 HP	
2065 SA	137'10"	5726	31.1	22.3	12.2	25.3	*11.6	60 HP	HEX BOLT, 5/16-18 GR 5 1.00" LG
2075 SA	157'10"	6026	36.3	31.1	13.7	35.3	*11.6	60 HP	
2085 SA	177'10"	6768	40.7	32.1	12.7	38.1	*11.6	70 HP	
2095 SA	197'10"	7027	46.4	40.7	14.4	48	*11.6	80 HP	
20105 SA	217'10"	8890	51.1	N/A	15.9	N/A	**13.92	80 HP	
20110 SA	227'10"	9700	54	N/A	17.1	N/A	**13.92	90 HP	
20120 SA	247'10"	10330	58.6	N/A	17.4	N/A	**13.92	100 HP	
2465 SA	141'2"	6381	32.1	23.4	12.5	26	*11.6	60 HP	HEX BOLT, 5/16-18 GR 5 1.00" LG
2475 SA	161'2"	6696	36.1	32	14.3	35.8	*11.6	70 HP	
2485 SA	181'2"	7453	42.3	32.6	13.7	38.6	*11.6	80 HP	
2495 SA	201'2"	7930	47.1	41.5	14.9	48.5	*11.6	80 HP	
24105 SA	221'2"	9605	52.5	N/A	16.3	N/A	**13.92	90 HP	
24110 SA	231'2"	10795	53.9	N/A	17.1	N/A	**13.92	100 HP	
24120 SA	251'2"	11070	60	N/A	18.4	N/A	**13.92	120 HP	

\* Extends out to 14.8'

\*\* Extends out to 16.63'

**Table 9. Swing-Away Transfer Specifications**

<b>Model</b>	<b>Belt Length</b>	<b>Weight (lbs)</b>	<b>HP Elec</b>	<b>HP Hyd (in<sup>3</sup>)</b>
1500	34'6"	700	7.5 HP	5.9 (H SERIES)
2000	41'6"	900	7.5 HP	6.2 (2000 SERIES)
2400	45'3"	1300	10 HP	8.0 (2000 SERIES)

# 10. Appendix

## 10.1. Power Swing Remote Transmitter Instructions

Figure 36 shows the controls and indicators for the power swing remote and receiver.

Figure 36. Remote Transmitter and Receiver Controls and Indicators

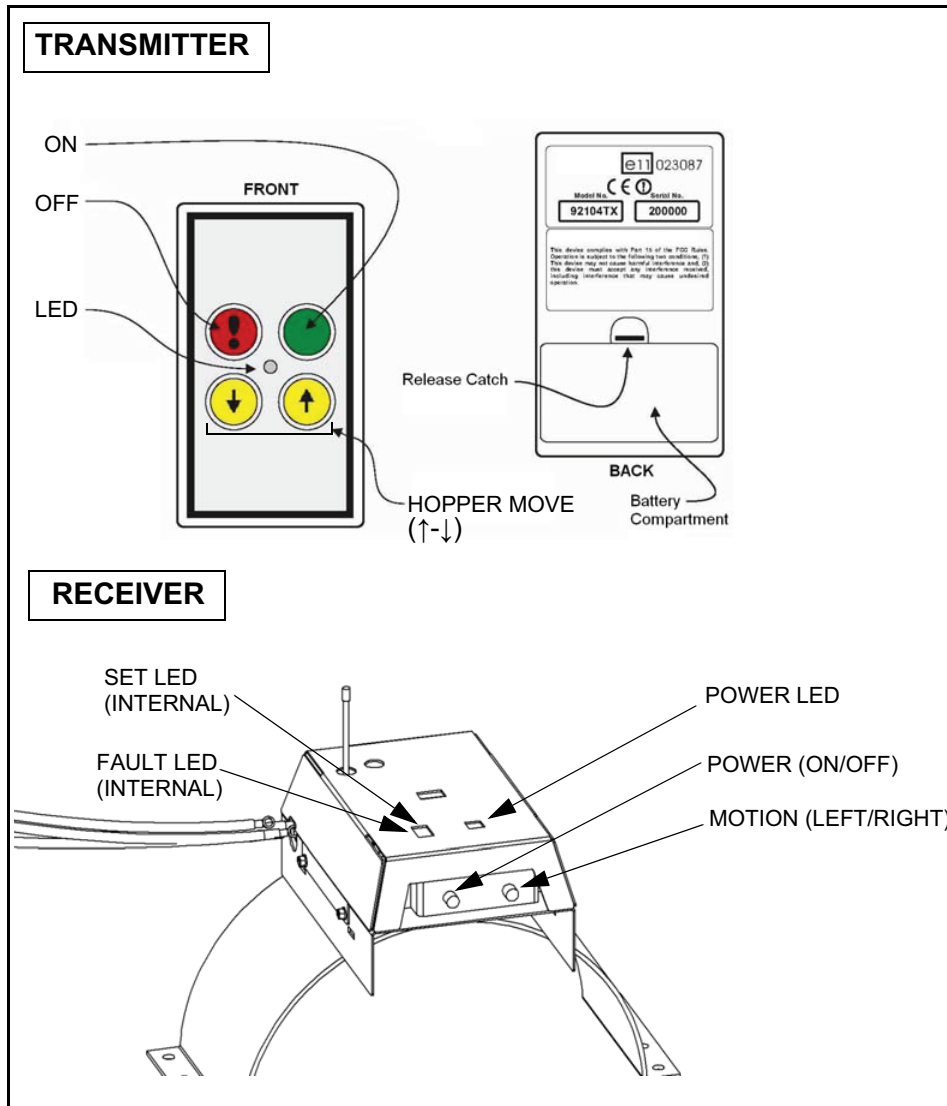

**Important**

The transmitter LED blinks on and off when the transmitter and receiver are active (turned on by the transmitter) and no other button is pressed. The LED turns fully on while a transmitter button is pressed, unless the transmitter battery is low, in which case the LED pulses on and off.

**NOTICE**

The transmitter automatically transmits a **STOP** signal after 30 minutes; this de-activates the receiver and the transmitter keypad.

**NOTICE**

The remote transmitter that comes with each power swing is normally factory programmed to function with the power swing receiver. Refer to specific instructions for programming additional or replacement remotes according to the serial number of the power swing receiver.

## 10.2. Programming Receivers

---

Turn on all the remote transmitters before programming.

**Note**

To de-register all remote transmitters from the receiver, hold down the OFF button on a remote for at least 60 seconds.

**TO REGISTER THE FIRST REMOTE TRANSMITTER:**

1. Switch OFF the receiver.

**Important**

Steps 2 and 3 must be done within 10 seconds of each other. The FAULT LED on the receiver flashes for the duration of the registration window.

2. Switch ON the receiver.
3. On the first remote, press the ON button and the yellow Down-Arrow Motion button at the same time and hold until the red light on the receiver SET LED illuminates solid red. Release buttons. The remote is programmed, and should be set aside.

**TO REGISTER A SECOND REMOTE TRANSMITTER:**

1. Switch OFF the receiver.

**Important**

Steps 2 and 3 must be done within 10 seconds of each other. The FAULT LED on the receiver flashes for the duration of the registration window.

2. Switch ON the receiver.
3. On a 2nd remote, press and release the ON button once, then press the ON button and the Down-Arrow Motion button at the same time and hold until the red light on the receiver SET LED illuminates solid red. Release buttons. The remote is programmed, and should be set aside.

**TO REGISTER A THIRD REMOTE TRANSMITTER:**

1. Switch OFF the receiver.

**Important**

Steps 2 and 3 must be done within 10 seconds of each other. The FAULT LED on the receiver flashes for the duration of the registration window.

2. Switch ON the receiver.
3. On a 3rd remote, press and release the ON button twice, then press the ON button and the Down-Arrow Motion button at the same time and hold until the red light on the receiver SET LED illuminates solid red. Release buttons. The remote is programmed, and should be set aside.

**TO REGISTER A FOURTH REMOTE TRANSMITTER:**

1. Switch OFF the receiver.

**Important**

Steps 2 and 3 must be done within 10 seconds of each other. The FAULT LED on the receiver flashes for the duration of the registration window.

2. Switch ON the receiver.
3. On a 4th remote, press and release the ON button three times, then press the ON button and the Down-Arrow Motion button at the same time and hold until the red light on the receiver SET LED illuminates solid red. Release buttons. The remote is programmed, and should be set aside.

# 11. Limited Warranty

**This warranty relates to Belt Conveyors (the “Product”) sold by AGI (referred to herein as the “Seller”) and applies only to the first user of the Product (meaning a purchaser directly from the Seller or from an authorized dealer or distributor of the Product, referred to herein as the “Buyer”).**

**This warranty shall only be effective if properly registered with the Seller in accordance with information provided to the Buyer at the time of sale.**

1. The Seller warrants to the Buyer that the Product is free from defects in material and workmanship **under normal and reasonable use** and in accordance with manufacturer’s manual.
2. This warranty applies only to defects in materials and workmanship and not to damage incurred in shipping or handling, through normal wear and tear, or damage due to causes beyond the control of the Seller such as lightning, fire, flood, wind, earthquake, excessive voltage, mechanical shock, water damage, or damage arising out of abuse, alteration, improper assembly, improper installation, improper maintenance or improper repair of the Product.
3. **The warranty period for the Product shall be two years from delivery of the Product to the Buyer where the Product is used in a normal farm operation. First year of warranty coverage of parts and repair labour, second year warranty coverage of parts only. Warranty period for the Product shall be 90 days from delivery of the Product to the Buyer where the Product is used in a commercial operation. No warranty is given where the Product was used to convey canola.** In the event that any part incorporated into the Product is manufactured and sold to the Seller by a third party vendor, such part is only warranted to the extent of the warranty given by that third party.
4. This warranty does not obligate the Seller to bear costs of travel in replacing defective parts.
5. The obligations set forth in this warranty are conditional upon the Buyer promptly notifying the Seller of any defect and completing reasonably required documentation and, if required, promptly making the Product available for correction.
6. The total liability of the Seller on any claim, whether in contract, tort or otherwise, arising out of, connected with, or resulting from the manufacture, sale, delivery, repair, replacement or use of the Product or any part thereof **shall not exceed the price paid for the Product** and the Seller shall not be liable for any special indirect, incidental or consequential damages caused by reason of the installation, modification, use, repair, maintenance or mechanical failure of the Product. **Consequential or special damages as used herein include, but are not limited to, lost or damaged products or goods, costs of transportation, lost sales, lost orders, lost income, increased overhead, labor and incidental costs and operational inefficiencies.**
7. The foregoing warranty is the entire warranty of the Seller to the Buyer and the Buyer shall not be entitled to rely upon any representation or warranty contained in any marketing material of the Seller in respect of the Product. The Seller neither assumes, nor authorizes any other person purporting to act on its behalf to modify or to change this warranty, nor to assume for it any other warranty or liability concerning the Product.

**WARRANTY VOID IF NOT REGISTERED**



# **AGI** **BATCO**

Shipping: 201 Industrial Drive, Swift Current, Saskatchewan S9H 5R4, CANADA

Mailing: Box 1750, Swift Current, Saskatchewan S9H 4J8, CANADA

Toll-Free: (877) 667-7421 (Canada & USA)

Phone: (306) 773-7779

Fax: (306) 778-2524

Website: [www.aggrowth.com](http://www.aggrowth.com)

Email: [sales@batco-rem.com](mailto:sales@batco-rem.com)

©Ag Growth International Inc. 2021

Printed in Canada

If you have any comments or questions on this manual, or find an error, email us at [comments@aggrowth.com](mailto:comments@aggrowth.com).  
Please include the part number listed on the cover page in your message.