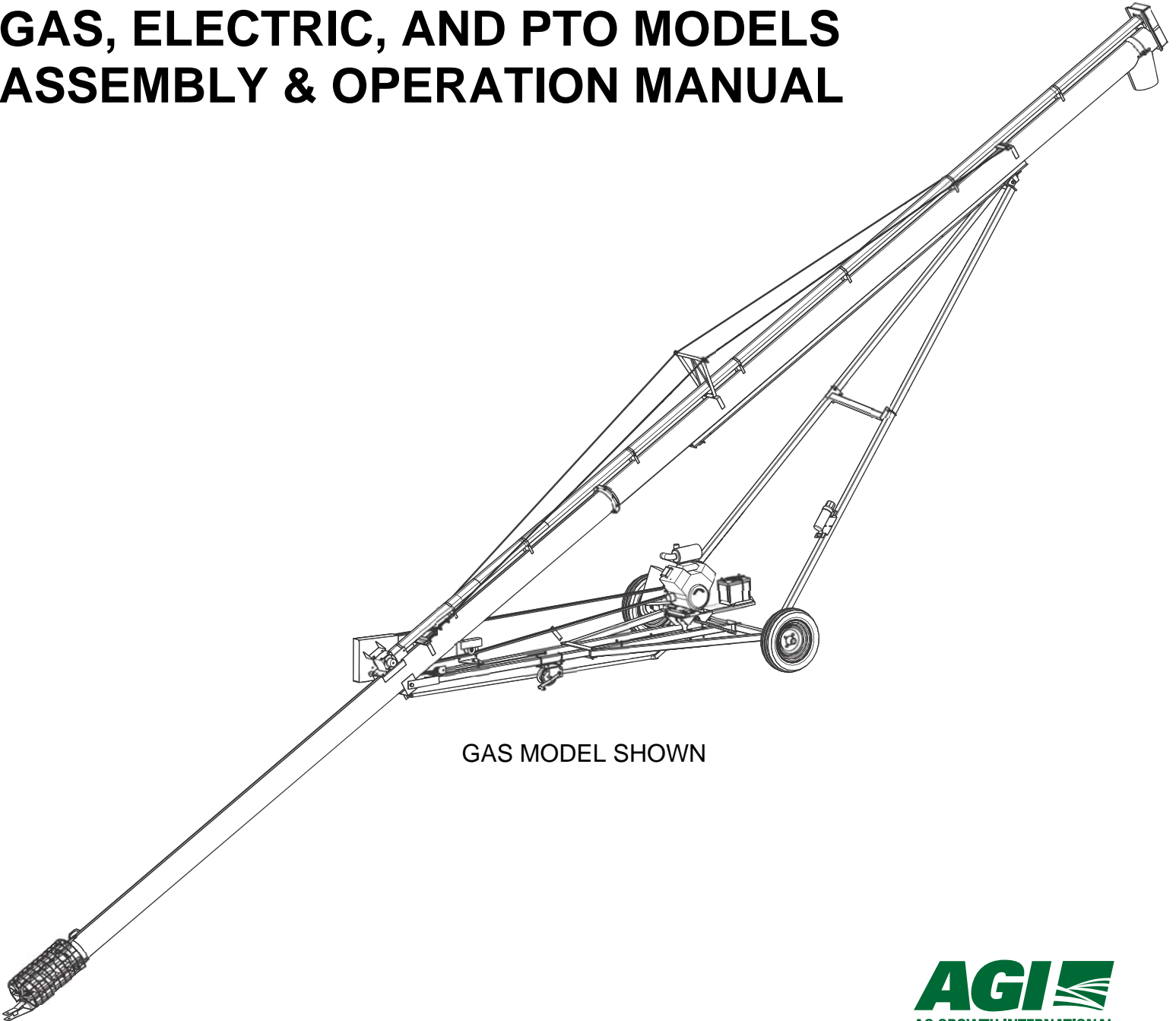




# TFX2 1051 GRAIN AUGERS

## GAS, ELECTRIC, AND PTO MODELS

### ASSEMBLY & OPERATION MANUAL



GAS MODEL SHOWN



Read this manual before using product. Failure to follow instructions and safety precautions can result in serious injury, death, or property damage. Keep manual for future reference.

Part Number: 30810 R2

Revised: 25/3/14



# TABLE OF CONTENTS

|   |           |
|---|-----------|
| <b>1. Introduction</b> .....                              | <b>5</b>  |
| 1.1. Description of the Equipment .....                   | 6         |
| <b>2. Safety</b> .....                                    | <b>7</b>  |
| 2.1. General Safety Information .....                     | 7         |
| 2.2. Assembly Safety .....                                | 8         |
| 2.3. Operating Safety .....                               | 9         |
| 2.4. Transport Safety .....                               | 9         |
| 2.5. Storage Safety .....                                 | 9         |
| 2.6. Maintenance Safety .....                             | 10        |
| 2.7. Safety Decals .....                                  | 12        |
| 2.7.1. Decal Installation/Replacement .....               | 12        |
| 2.7.2. Safety Decal Locations .....                       | 12        |
| <b>3. Assembly</b> .....                                  | <b>17</b> |
| 3.1. General Assembly .....                               | 17        |
| 3.1.1. Tube & Flighting Assembly .....                    | 18        |
| 3.1.2. Intake Assembly .....                              | 19        |
| 3.1.3. Drive Shaft Assembly .....                         | 20        |
| 3.1.4. Gearbox Assembly .....                             | 21        |
| 3.1.5. Drive Shaft Shield & Pulley Guard Assembly .....   | 22        |
| 3.2. Truss & Cable Assembly .....                         | 23        |
| 3.2.1. Bridge/Cable Installation & Cable Tightening ..... | 23        |
| 3.2.2. Lift Cable Installation .....                      | 25        |
| 3.3. Wheel Hub Assembly .....                             | 25        |
| 3.4. Tire Assembly .....                                  | 26        |
| 3.5. Frame Assembly .....                                 | 27        |
| 3.5.1. Lower Frame Assembly .....                         | 27        |
| 3.5.2. Lift Arm Assembly .....                            | 29        |
| 3.5.3. Attaching to Tube .....                            | 30        |
| 3.5.4. Cross Member / Cable Pulley Assembly .....         | 32        |
| 3.5.5. Hand Winch Assembly .....                          | 33        |
| 3.5.6. Idler Assembly .....                               | 34        |
| 3.6. Plastic Manual Holder .....                          | 35        |
| 3.7. Drive Assembly .....                                 | 36        |
| 3.7.1. Gas Engine & Components .....                      | 37        |
| 3.7.2. Electric Motor & Components .....                  | 40        |
| 3.7.3. PTO & Components .....                             | 41        |
| 3.7.4. Australian Belt Guard Assembly .....               | 44        |
| 3.8. Decal Installation .....                             | 49        |
| 3.8.1. Decal Placement .....                              | 49        |
| <b>4. Transport &amp; Placement</b> .....                 | <b>51</b> |
| 4.1. Transport Procedures .....                           | 51        |
| 4.2. Placement Procedures .....                           | 54        |

# TABLE OF CONTENTS

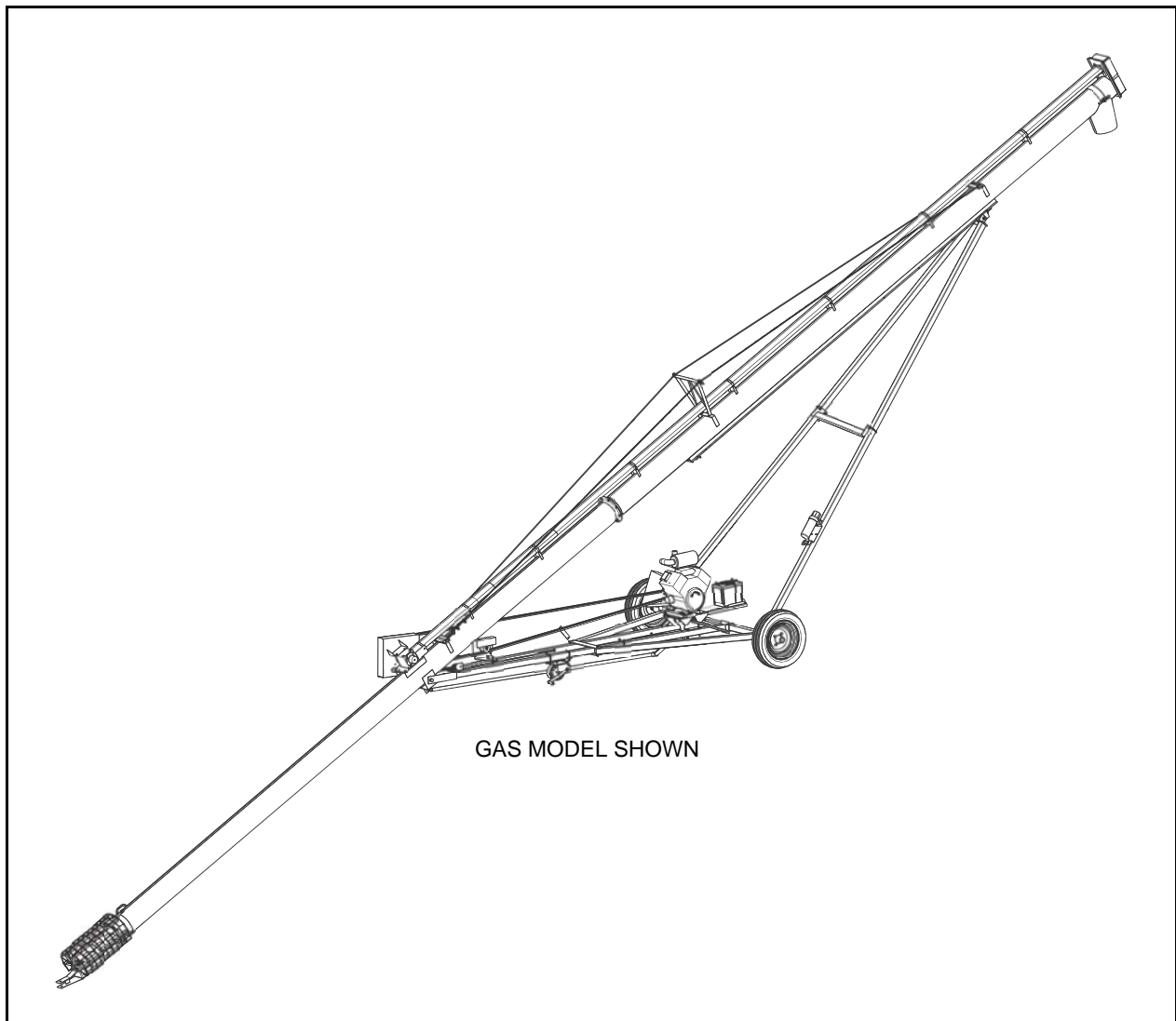
|   |           |
|---|-----------|
| <b>5. Operation .....</b>                     | <b>55</b> |
| 5.1. Components & Controls .....              | 55        |
| 5.2. Auger Drive & Lockout.....               | 56        |
| 5.2.1. Gas Engine .....                       | 56        |
| 5.2.2. Electric Motor .....                   | 56        |
| 5.2.3. PTO Driveline .....                    | 56        |
| 5.3. Operating Procedures .....               | 57        |
| 5.3.1. Break-in Period .....                  | 57        |
| 5.3.2. Operation .....                        | 57        |
| 5.3.3. Shutdown.....                          | 59        |
| 5.3.4. Cleanout .....                         | 60        |
| <b>6. Maintenance &amp; Storage.....</b>      | <b>61</b> |
| 6.1. General Maintenance Procedures.....      | 61        |
| 6.1.1. Fluids & Lubricants .....              | 61        |
| 6.1.2. Maintenance Intervals.....             | 62        |
| 6.1.3. Visual Inspection.....                 | 62        |
| 6.1.4. Servicing Upper Chain Drive .....      | 63        |
| 6.1.5. Greasing Machine.....                  | 64        |
| 6.1.6. Cleaning Machine .....                 | 64        |
| 6.1.7. Repacking Wheel Bearings .....         | 64        |
| 6.1.8. Tightening Wheel Bolts.....            | 65        |
| 6.1.9. Servicing Engine.....                  | 65        |
| 6.1.10. Checking Gear Box Oil Levels.....     | 65        |
| 6.1.11. Changing Gearbox Oil .....            | 65        |
| 6.1.12. Servicing Truss Cables.....           | 66        |
| 6.1.13. Servicing PTO Driveline.....          | 66        |
| 6.1.14. Servicing Winch .....                 | 67        |
| 6.1.15. Replacing Belts.....                  | 67        |
| 6.1.16. Tightening Belts .....                | 68        |
| 6.2. General Storage Procedures.....          | 69        |
| <b>7. Troubleshooting .....</b>               | <b>71</b> |
| <b>8. Appendix.....</b>                       | <b>73</b> |
| 8.1. Bolt Torque Values .....                 | 73        |
| 8.2. Tightening O-Ring Fittings.....          | 74        |
| 8.3. Tightening Flare Type Tube Fittings..... | 75        |
| Warranty.....                                 | 77        |
| .....   | 77        |

# 1. Introduction

Congratulations on the purchase of your new Westfield TFX2 1051 Auger. This piece of equipment will complement your agricultural operation by aiding in the safe and efficient movement of grain, pulse crops, fertilizer, or any other granular materials.

Your new Westfield auger will serve you well if you understand how it operates, if you use it properly, and if you care for it properly. This manual is intended to help you assemble your equipment in a safe, efficient, and trouble-free manner. Please read this manual completely before assembling your new grain auger.

Should any information remain unclear after thoroughly reviewing this manual, contact your Westfield Dealer for clarification before assembling your auger. Knowing the serial number and date of purchase will save time in getting your questions answered. Please write down this information in the space provided below.



GAS MODEL SHOWN

|   |  |
|---|--|
| <b>Serial Number:</b>   |  |
| *Serial number is located on the right side of the top end of the lower tube. |  |

## 1.1. DESCRIPTION OF THE EQUIPMENT

---

This Westfield Auger is designed to efficiently handle grain, pulse crops, or other granular materials. The auger comes field-ready and equipped with such features as reinforced, low-pitch flighting at the intake for high capacity and longer wear, a belt engaging lever that can be operated from either side, and a frame design that allows for extra bottom reach for bin load-out applications.

Many features incorporated into this machine are the result of suggestions made by customers like you. Read this manual carefully to learn how to operate the machine safely and how to adjust it to provide maximum efficiency. By following the operating instructions in conjunction with a good maintenance program, your auger will provide many years of trouble-free service.

# 2. Safety

## 2.1. GENERAL SAFETY INFORMATION



The Safety Alert symbol identifies important safety messages on the product and in the manual. When you see this symbol, be alert to the possibility of personal injury or death. Follow the instructions in the safety messages.

Why is SAFETY important?

- Accidents disable and kill.
- Accidents cost.
- Accidents can be avoided.

**SIGNAL WORDS:** Note the use of the signal words **DANGER**, **WARNING**, **CAUTION**, and **NOTICE** with the safety messages. The appropriate signal word for each message has been selected using the definitions below as a guideline.

### DANGER



Indicates an imminently hazardous situation that, if not avoided, will result in serious injury or death.

### WARNING



Indicates a hazardous situation that, if not avoided, could result in serious injury or death.

### CAUTION



Indicates a hazardous situation that, if not avoided, may result in minor or moderate injury.

### NOTICE

Indicates a potentially hazardous situation that, if not avoided, may result in property damage.

**YOU** are responsible for the **SAFE** use and maintenance of your equipment. **YOU** must ensure that you and anyone else who is going to work around the equipment understands all procedures and related **SAFETY** information contained in this manual.

Remember, **YOU** are the key to safety. Good safety practices not only protect you, but also the people around you. Make these practices a working part of your safety program.

**Important:** *Below are general instructions that apply to all safety practices. Any instructions specific to a certain safety practice (e.g., Operational Safety), can be found in the appropriate section. Always read the complete instructional sections and not just these safety summaries before doing anything with the equipment.*



- It is the equipment owner, operator, and maintenance personnel's responsibility to read and understand **ALL** safety instructions, safety decals, and manuals and follow them when assembling, operating, or maintaining the equipment. All accidents can be avoided.
- Equipment owners must give instructions and review the information initially and annually with all personnel before allowing them to operate this product. Untrained users/operators expose themselves and bystanders to possible serious injury or death.
- Use this equipment for its intended purposes only.
- Do not modify the equipment in any way without written permission from the manufacturer. Unauthorized modification may impair the function and/or safety, and could affect the life of the equipment. Any unauthorized modification of the equipment voids the warranty.
- Do not allow any unauthorized person in the work area.

## 2.2. ASSEMBLY SAFETY

---

- Read the instructions and familiarize yourself with the subassemblies and hardware making up the equipment.
- The components are large, heavy, and can be hard to handle. Be sure to use the proper tools, stands, jacks, and hoists for the job.
- Have 2 people handle the heavy, bulky components.
- Place safety stands or large blocks under the machine or components before going beneath the component for assembly.
- Stay away from overhead power lines and obstructions when lifting the machine during assembly. Electrocution can occur without direct contact. Contact with obstructions can damage components or cause them to fail.
- Tighten all fasteners to their specified torque before using the machine.



## 2.3. OPERATING SAFETY

---

- Ensure guards are present and secure.
- Clear the work area of unauthorized persons, particularly small children and pets.
- Clean the work area to prevent slipping or tripping.
- Ensure a fully equipped first aid kit is on hand and that you know how to use it.
- Ensure a working fire extinguisher is on hand and that you know how to use it.
- Be certain the PTO driveline is securely attached to the jackshaft and to the tractor.
- Before starting tractor, be certain that power to PTO is in the off position
- Keep hands, feet, hair, and clothing away from all moving or rotating parts.

## 2.4. TRANSPORT SAFETY

---

- Ensure tires are inflated to the tire manufacturer's recommended pressure.
- Check with local authorities regarding transportation of agricultural equipment on public roads. Obey all applicable laws and regulations.
- Make sure that all lights and reflectors required by the local highway and transport authorities are in place, are functioning, and can be seen clearly by all overtaking and oncoming traffic.
- Be sure the unit is hitched securely to the towing vehicle.
- Do not allow riders while transporting.
- Display a Slow Moving Vehicle emblem when transporting below 25 mph (40 km/h).
- Use hazard-warning flashers when transporting with a tractor unless prohibited.
- Keep to the right and yield the right-of-way to allow faster traffic to pass.
- Never transport faster than the road terrain or conditions will allow you to do safely.
- Use caution when making corners or meeting traffic.
- Use caution when approaching height-limiting objects.
- Take special care and precautions when transporting during times of limited visibility such as rain, snow, fog, dusk, or at night. It is recommended that you wait for a more appropriate time to move.
- Use caution when turning or cornering.
- Do not transport auger on a slope greater than 20°. The auger may overturn.

## 2.5. STORAGE SAFETY

---

- Store in an area away from human activity.
- Do not permit children to play on or around the stored machine.

## 2.6. MAINTENANCE SAFETY

---

- Shut off and disable the power source before working on the machine.
- Ensure service area is clean and dry.
- Ensure electrical outlets and tools are properly grounded.
- Use proper tools for the job.
- Ensure there is adequate lighting to perform the job safely.
- Wear safety gear that is appropriate for the job being performed.
- Use extra caution when cleaning and servicing augers because flighting edges can become sharp.
- Follow proper procedures when mounting a tire on a rim. If in doubt, have a qualified tire repair service perform the required maintenance.
- Install and secure all guards after maintenance work is completed.

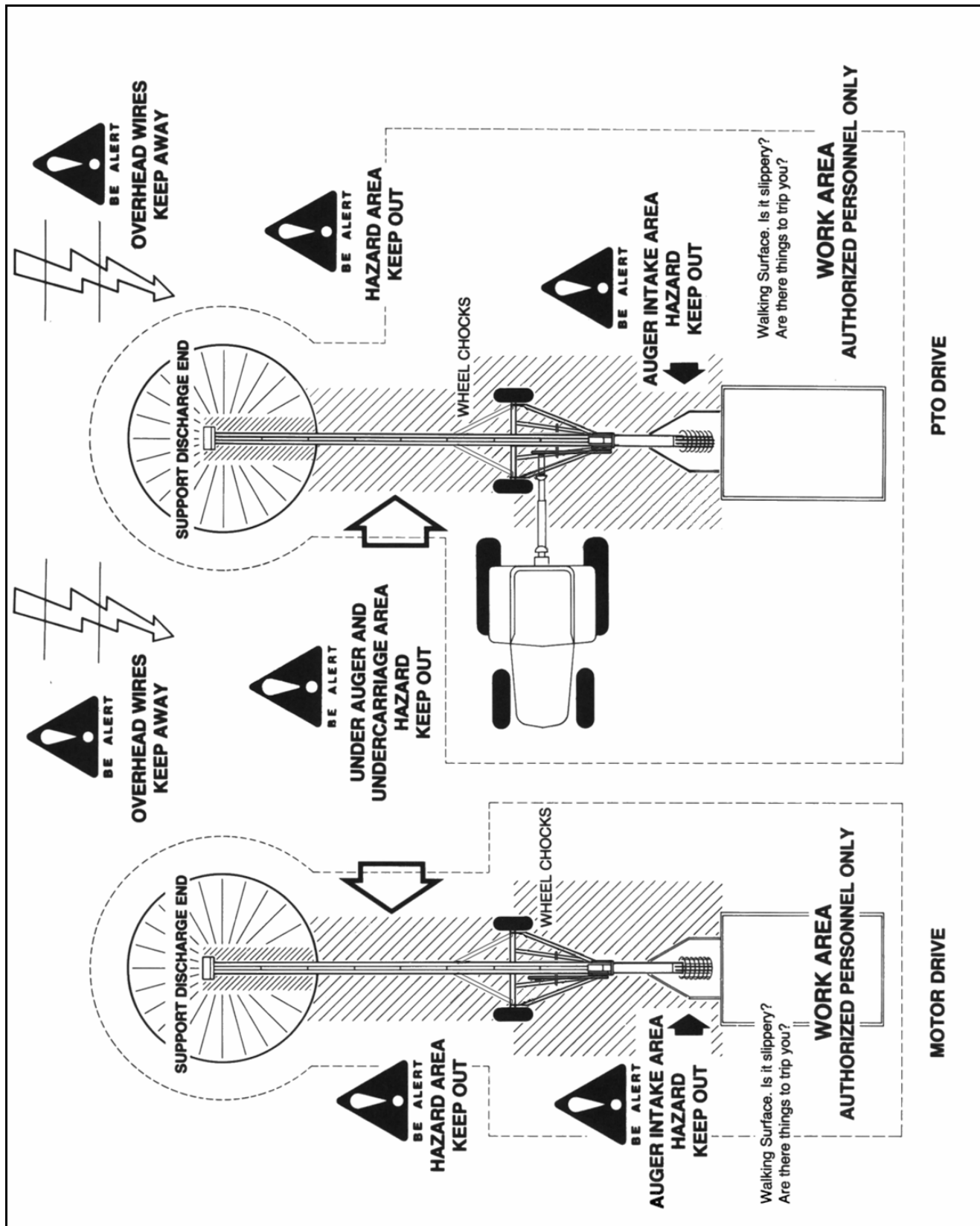


Figure 2.1 Safety Work Area

## 2.7. SAFETY DECALS

---

- Keep safety decals clean and legible at all times.
- Replace safety decals that are missing or have become illegible. See decal location figures that follow.
- Replaced parts must display the same decal(s) as the original part.
- Replacement safety decals are available **free of charge** from your distributor, dealer, or factory.

### 2.7.1. DECAL INSTALLATION/REPLACEMENT

---

1. Decal area must be clean and dry, with a temperature above 50°F (10°C).
2. Decide on the exact position before you remove the backing paper.
3. Align the decal over the specified area and carefully press the small portion with the exposed sticky backing in place.
4. Slowly peel back the remaining paper and carefully smooth the remaining portion of the decal in place.
5. Small air pockets can be pierced with a pin and smoothed out using the sign backing paper.

### 2.7.2. SAFETY DECAL LOCATIONS

---

Replicas of the safety decals that are attached to the equipment and their messages are shown in the figure(s) that follow. Safe operation of the equipment requires that you familiarize yourself with the various safety decals and the areas or particular functions that the decals apply to, as well as the safety precautions that must be taken to avoid serious injury, death, or damage.


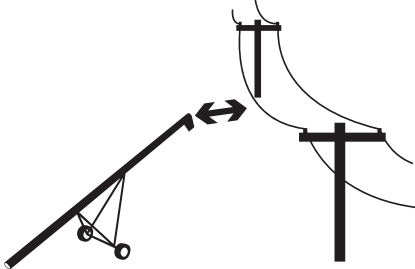

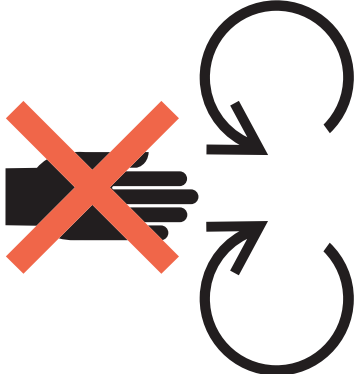



|  |  |
|--|--|
| <b>⚠ DANGER</b>  |  |
|   |    |
| <b>ELECTROCUTION HAZARD</b>  |  |
| <p>To prevent death or serious injury:</p> <ul style="list-style-type: none"> <li>• When operating or moving, keep equipment away from overhead power lines and devices.</li> <li>• Fully lower equipment before moving.</li> </ul> <p>This equipment is not insulated.<br/>                 Electrocution can occur without direct contact.</p> |  |
| <small>20817<br/>Made in Canada</small>  |  |
| DECAL #20817   |  |
| <b>⚠ DANGER</b>  |  |
|   |    |
| <b>ROTATING FLIGHTING HAZARD</b>   |  |
| <p>To prevent death or serious injury:</p> <ul style="list-style-type: none"> <li>• KEEP AWAY from rotating auger flighting.</li> <li>• DO NOT remove or modify auger flighting guards, doors, or covers. Keep in good working order. Have replaced if damaged.</li> </ul>   |  |
| <small>20813<br/>Made in Canada</small>  | <ul style="list-style-type: none"> <li>• DO NOT operate the auger without all guards, doors, and covers in place.</li> <li>• NEVER touch the auger flighting. Use a stick or other tool to remove an obstruction or clean out.</li> <li>• Shut off and lock out power to adjust, service, or clean.</li> </ul> |
| DECAL #20813   |  |


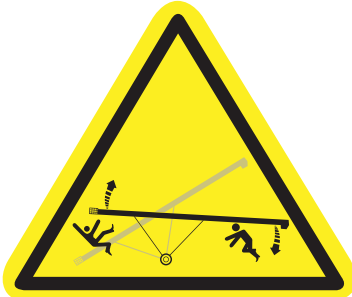

Figure 2.2 Danger Decals

|  <b>WARNING</b>   |   |
|--|---|
|   |  |
| <p>To prevent serious injury or death:</p> <ul style="list-style-type: none"> <li>• Read and understand the manual before assembling, operating, or maintaining the equipment.</li> <li>• Only trained personnel may assemble, operate, or maintain the equipment.</li> <li>• Children and untrained personnel must be kept outside of the work area.</li> <li>• If the manual, guards, or decals are missing or damaged, contact factory or dealer for replacements.</li> <li>• Lock out power before performing maintenance.</li> <li>• To prevent equipment collapse, support equipment tube while disassembling certain components.</li> <li>• Electric motors must be grounded. Disconnect power before resetting overloads.</li> </ul> |   |
| Made in Canada   | 20807   |

DECAL #20807

|  <b>WARNING</b>  |   |
|--|---|
|    |  |
| <p><b>ENTANGLEMENT HAZARD</b></p> <p>To prevent serious injury or death:</p> <ul style="list-style-type: none"> <li>• Keep body, hair, and clothing away from rotating pulleys, belts, chains, and sprockets.</li> <li>• Do not operate with any guard removed or modified. Keep guards in good working order.</li> <li>• Shut off and remove key or lock out power before source before inspecting or servicing machine.</li> </ul> |   |
| Made in Canada   | 20804   |

DECAL #20804

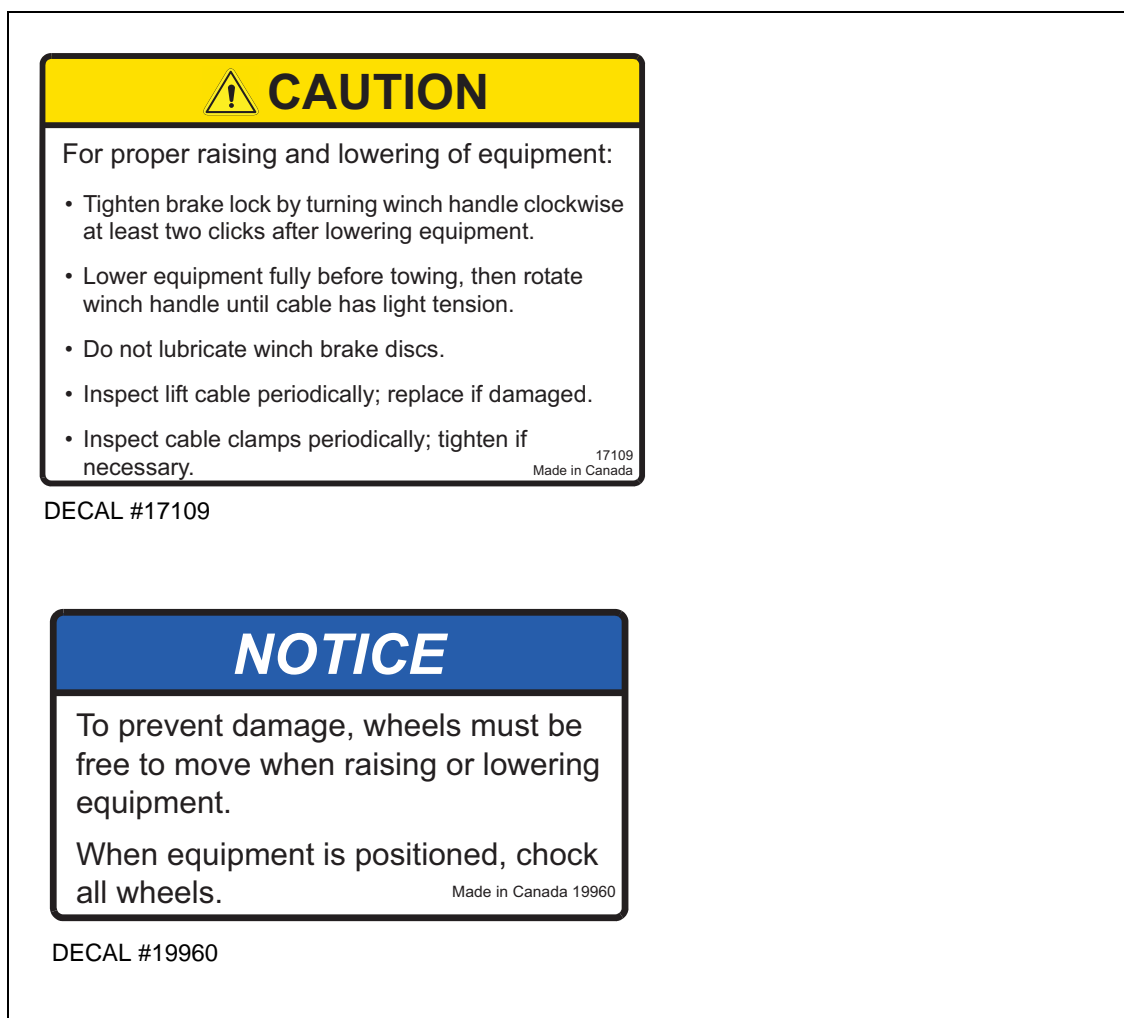
|  <b>WARNING</b>   |   |
|--|---|
|   |  |
| <p><b>UPENDING HAZARD</b></p> <p>To prevent death or serious injury:</p> <ul style="list-style-type: none"> <li>• Anchor intake end and/or support discharge end to prevent upending.</li> <li>• Auger intake end must always have downward weight. Do not release until attached to tow bar or resting on ground.</li> <li>• Do not raise auger intake end above tow bar height.</li> <li>• Empty auger and fully lower before moving.</li> </ul> |   |
| 20811<br>Made in Canada  |   |

DECAL #20811

|  <b>WARNING</b>   |       |
|--|-------|
| <p><b>TRANSPORT HAZARD</b></p> <p>To prevent serious injury or death:</p> <ul style="list-style-type: none"> <li>• Securely attach equipment to vehicle with correct pin and safety chains.</li> <li>• Use a tow vehicle to move equipment.</li> </ul> |       |
| Made in Canada   | 17113 |

DECAL #17113

Figure 2.3 Warning Decals



**Figure 2.4 Caution and Notice Decals**

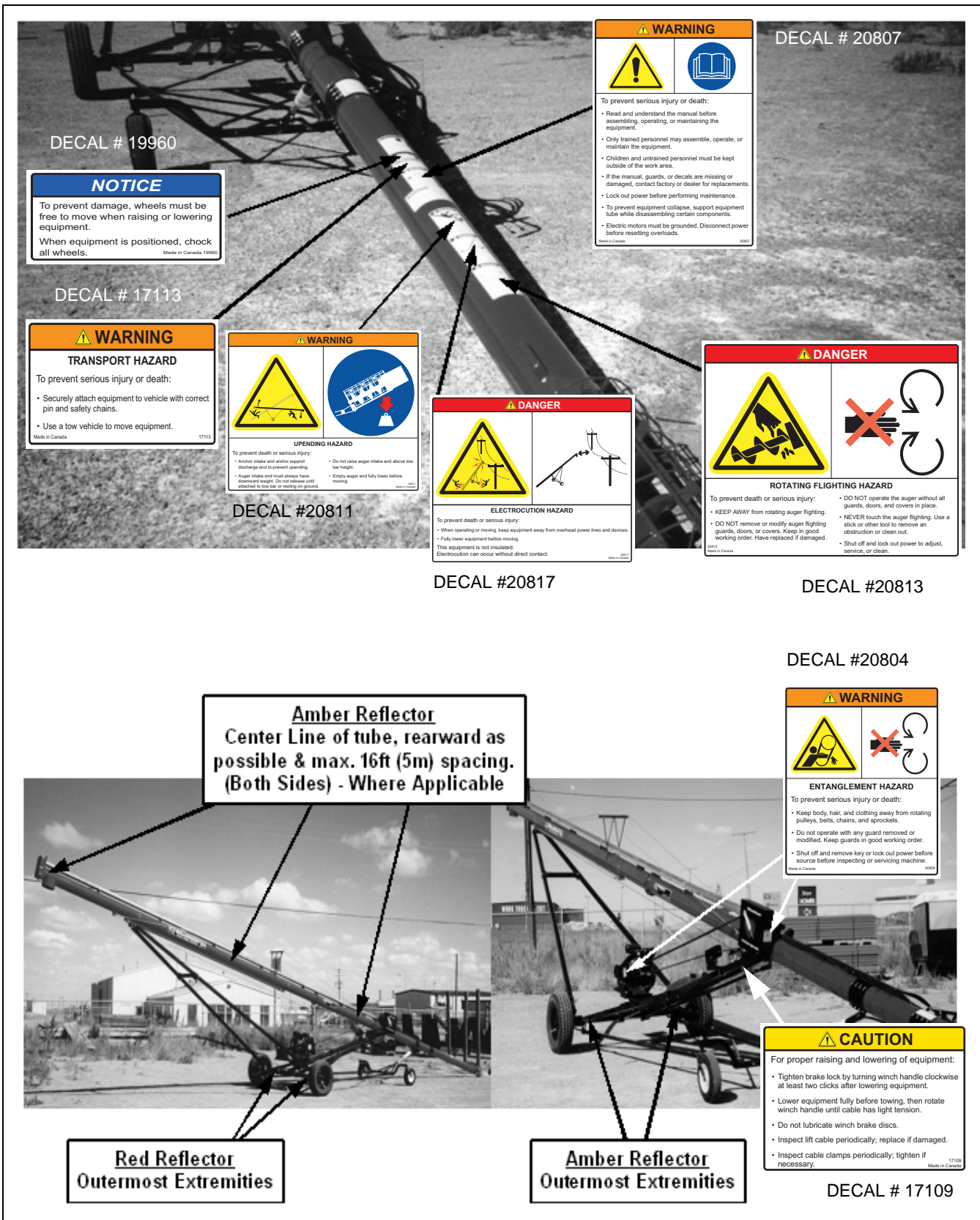


Figure 2.5 Safety Decal Locations

*If safety signs have been damaged, removed, or become illegible, or if parts are replaced without safety signs, new signs must be applied. New safety signs are available from your authorized dealer.*



# 3. Assembly

**WARNING** Before continuing, ensure you have read and understand the relevant information in the safety section. Safety information is provided to help prevent serious injury, death, or property damage.

Before starting the assembly of your new auger, please read the following instructions carefully, and familiarize yourself with all the sub-assemblies and hardware making up the auger. Ensure that all parts are on hand, arranging them for easy access as required. Assembly should be carried out in a large open area with a level surface. Do not take chances with safety. The components are large, heavy, and can be hard to handle. Be sure to use the proper tools, stands, jacks, and hoists for the job.

**Important:** These instructions are written on the assumption that two or more people will be available for the assembly procedure. Because of the weight, it is unwise to attempt assembly of the auger alone.

➔ Augers are available in various combinations. In most instances, the following instructions will apply to all augers. Where the assembly information for a particular set-up varies from a given step, additional instructions are included, indicated by an arrow at the appropriate point in the text.

**Note:** When tightening all fasteners, refer to Appendix for proper torque specifications.

## 3.1. GENERAL ASSEMBLY

---

1. Select an assembly area that is level, has a firm or hard surface, and is free of debris. Be sure it is large enough to allow access from all sides when the components are being assembled.
2. If assembling inside a building, be sure the ceiling is at least 14' (4.27 m) high to provide clearance when installing the undercarriage.
3. Bring all the tools, blocks, stands, jacks, and hoists to the assembly area before starting.

The following tools and equipment are required to assemble the machine

|     |  |
|-----|--|
| 2-4 | Pipe stands  |
| 2   | Saw horses (support capacity of 1200 lb, 544 kg)   |
| 1   | Standard socket set and wrench set   |
| 1   | Torque wrench  |
| 1   | Standard 25' (7.7 m) tape measure  |
| 1   | 2' (600 mm) level  |
| 1   | 8" (200 mm) level, magnetic  |
| 2   | C-clamps or vice grips   |
| 1   | Lifting device with minimum reach of 12' (3.7 m) and 4000-6000 lb (1800 to 2700 kg) lifting capacity |
| 1   | 100' measuring tape  |
| 1   | Tire pressure gauge  |
| 1   | Tire chuck   |

### 3.1.1. TUBE & FLIGHTING ASSEMBLY

**Note:** See Table 3.1 for the number of tube sections and their lengths and Figures 3.1 and 3.2 for the assembly procedure.

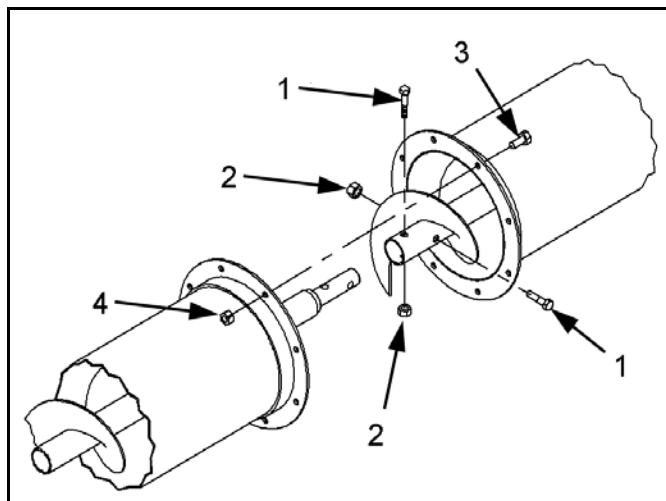
1. Align tube sections on a series of stands, placing a saw horse at each end with a stand near the flanges. Set the stand height so flanges are flush and level.
2. Slide the lower flighting shaft into the upper flighting shaft with flight ends butting together for continuous flow. Secure with two 1/2" x 2-3/4" bolts and 1/2" locknuts.
3. Slide tube sections together and insert the eight 7/16" x 1" bolts (3) and 7/16" locknuts (4). Ensure that the gearbox mount and bearing brackets are at the top of each tube and aligned tube to tube.
4. Slide roller track shoe (5) onto track.

**Table 3.1**

| Model     | Total Number of Tube Sections | Lower Tube Section Length | Upper Tube Section Length |
|-----------|-------------------------------|---------------------------|---------------------------|
| TFX2 1051 | 2                             | 25'<br>(7.62 m)           | 25'<br>(7.62 m)           |

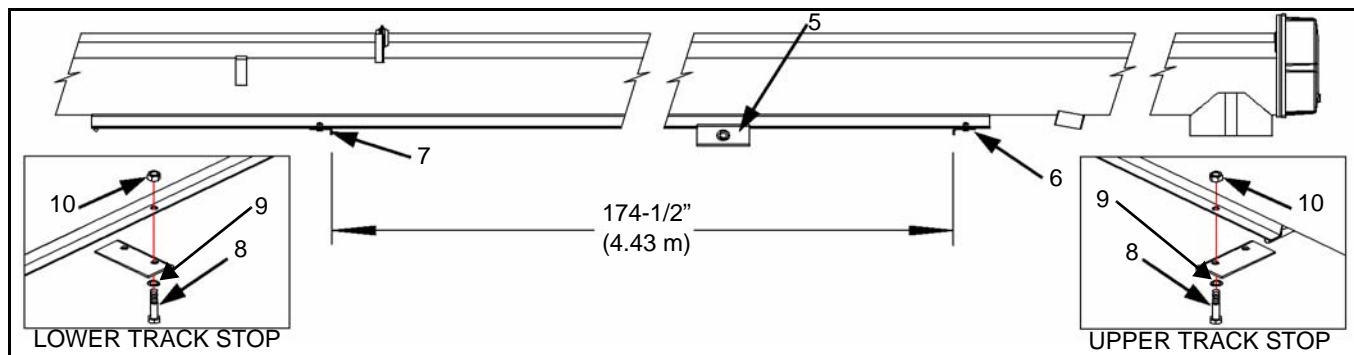
**Note:** Flight shaft connections, as well as flight connection bolts should slide into place easily. Do not force into place.

5. Attach the upper angle-iron track stop (6) to the set of holes in the track closest to the discharge end. Secure with two 7/16" x 1" bolts (8), 7/16" flat washers (9), and locknuts (10). See Figure 3.2.



**Figure 3.1**

6. Position the lower angle-iron track stop (7) 174-1/2" (4.43 m) from the upper track stop (6), toward the intake end, measuring from the inside flanges. Secure with two 7/16" x 1" bolts (8), 7/16" flat washers (9), and locknuts (10).

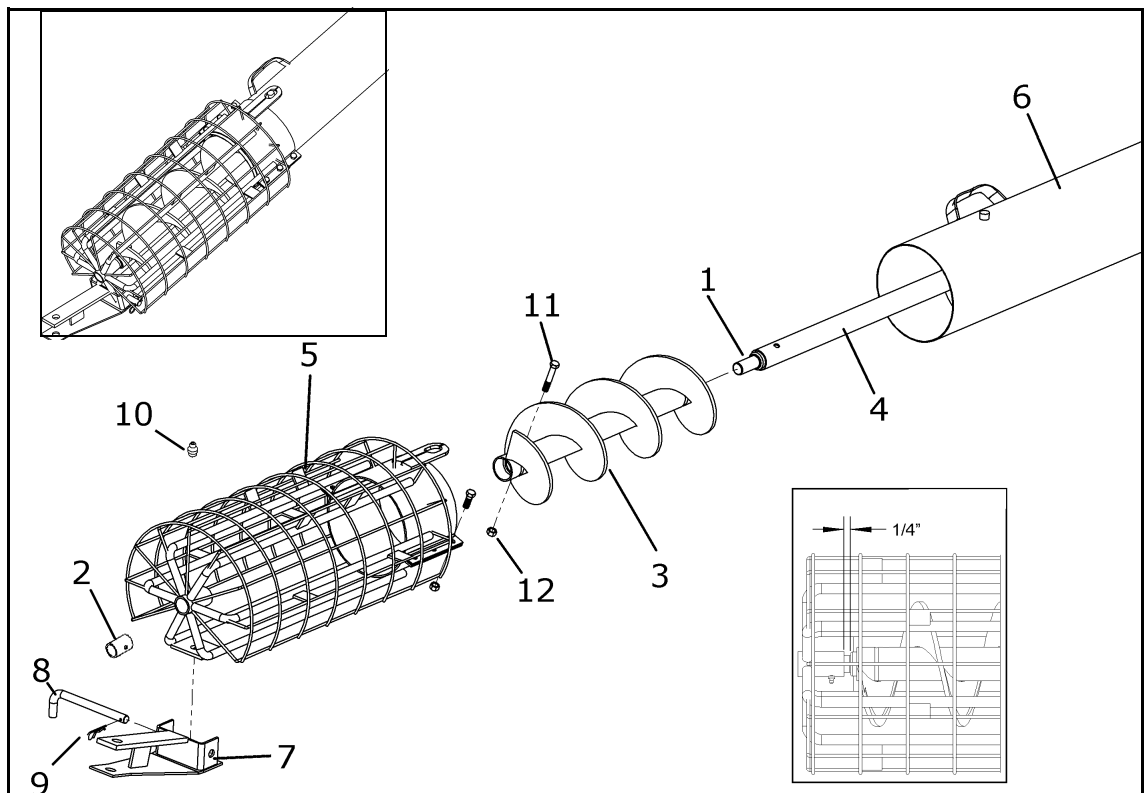


**Figure 3.2**

## 3.1.2. INTAKE ASSEMBLY

**Note:** See Figure 3.3 for assembly.

1. Clean dirt and paint from lower flying stub (1) and from inside of the bushing (2) on the intake.
2. Intake flighting (3) is factory assembled to the lower flying shaft (4) with one 3/8" x 3" bolt and locknut.
3. Slide the bolt-on intake guard (5) over the intake flight (3) and onto the lower tube (6). Make sure the intake retention loop on the intake guard loops around the retention pin on the lower tube as shown in Figure 3.3.
4. Maintain a 1/4" (0.6 cm) clearance between the bushing and the end of the flight as shown in Figure 3.3 (inset). Attach the intake guard to the lower tube using six 7/16" x 1" bolts and 7/16" locknuts. **TIGHTEN SECURELY.**
5. Attach the hitch clevis (7) to the intake guard (5) with a 5/8" clevis pin (8) and a hairpin (9).
6. Make sure that the grease zerk (10) is installed and secure. Grease the bushing. See "Maintenance & Storage" on page 61.



**Figure 3.3**

### 3.1.3. DRIVE SHAFT ASSEMBLY

**Note:** See Table 3.2 for the lower driveshaft length and diameter and Figure 3.4 for assembly.

1. Clean dirt and paint from the driveshaft ends (1, 2) and the shaft connector (3). Refer to Figure 3.4.
2. After installing the Woodruff key (4), slide connector (3) halfway onto the last pre-installed driveshaft segment (1) as shown in Figure 3.4.

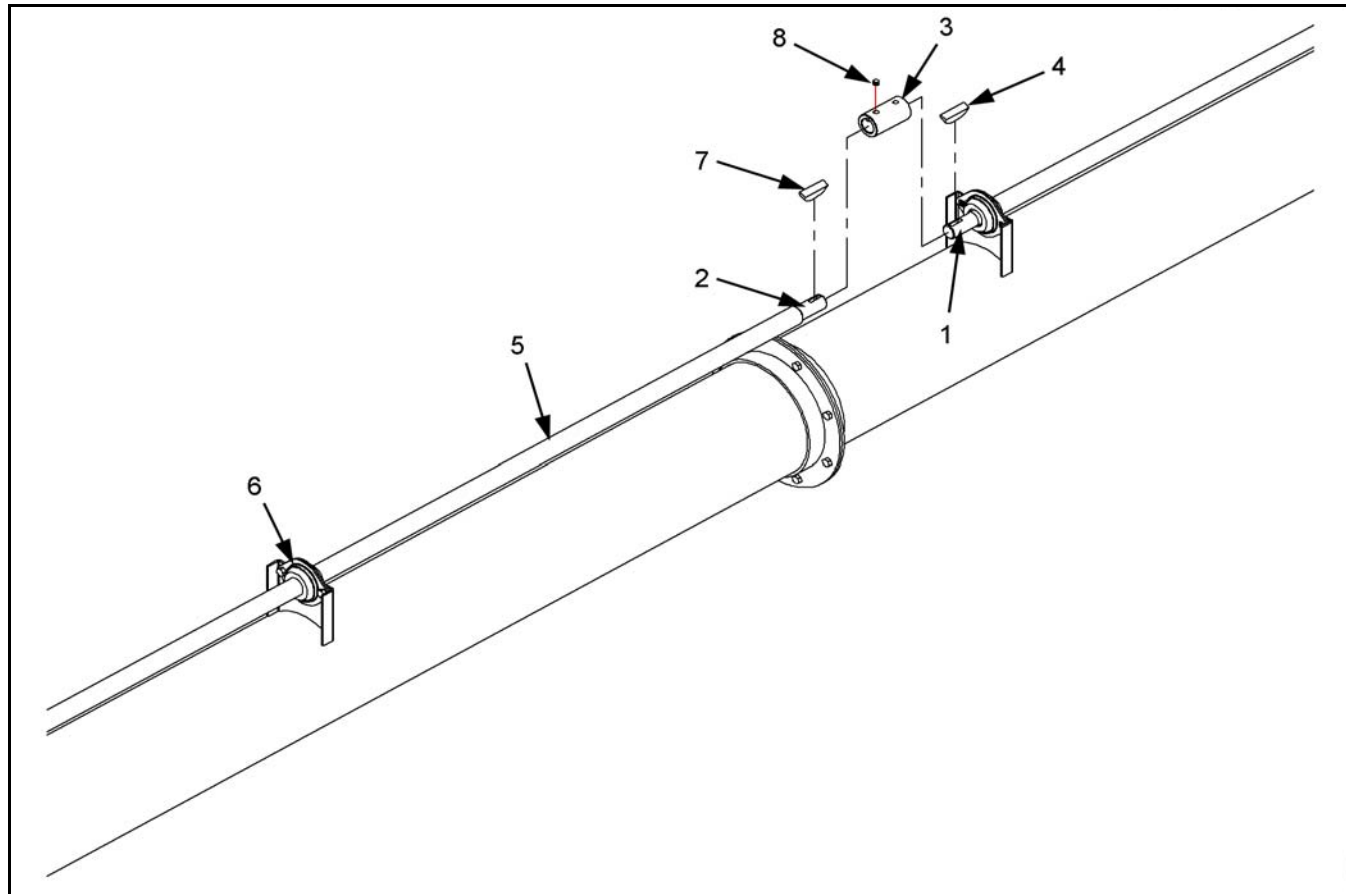
**Note:** It may ease installation if the bolts on the bearing(s) are loosened or removed.

3. Slip the lower driveshaft segment (5) through the bearing(s) (6) on the lower tube section, install a Woodruff key (7), and slide it into the shaft connector (3) as shown in Figure 3.4.
4. Center the shaft connector on the keys and tighten the set screws (8). Refer to Figure 3.4.

**Important:** Place a few drops of oil at each driveshaft bearing location to allow for a break-in period. These bearings will not require any further lubrication as they are self-lubricating.

**Table 3.2**

| Model     | Lower Driveshaft |                    |
|-----------|------------------|--------------------|
|           | Length           | Diameter           |
| TFX2 1051 | 125"<br>(3.18 m) | 1-1/4"<br>(3.2 cm) |



**Figure 3.4**

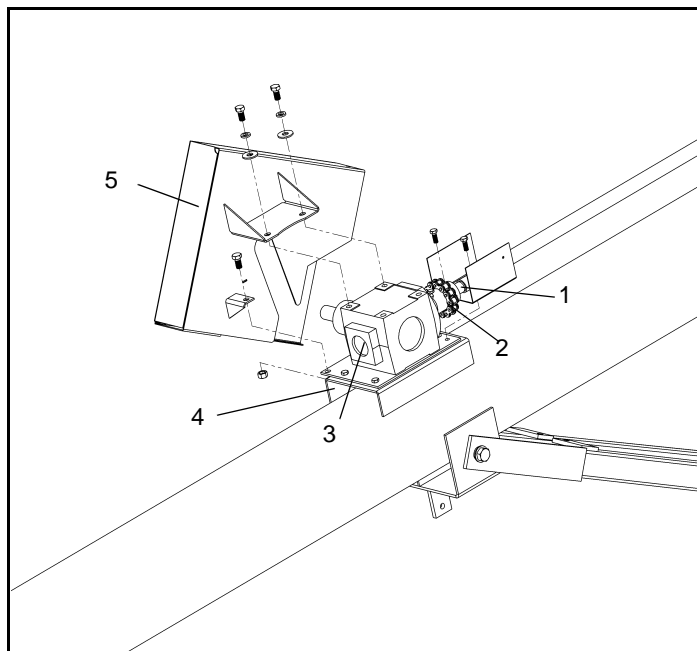
### 3.1.4. GEARBOX ASSEMBLY

**Note:** Check the gearbox oil level; gearbox should be half full. Use only EP90 lube oil and fill to HALF FULL only. See "Operation" on page 55 and "Maintenance & Storage" on page 61 for the correct maintenance procedures.

1. Install a woodruff in the lower driveshaft (1) and slide the chain coupler (2) and gearbox assembly (3) onto the driveshaft.
2. When the driveshaft is installed far enough into the coupler, secure the gearbox assembly to the welded mounting bracket (4) on the tube. Install the chain coupler shield when bolting the gearbox assembly with four 3/8" x 1" bolts and locknuts (Figure 3.5).
3. Tighten all the bolts in the gearbox mount.
4. Tighten set screw on the chain coupler ensuring that there is a 1/16" gap between the chain coupler sprockets.

**Note:** The ends of the gearbox shaft and the driveshaft should be flush with the inside of the chain coupler sprockets.

5. If the driveshaft is too long or too short, do the following:
  - If driveshaft is too long, take up the extra length in the straight connector.
  - If driveshaft is too short, remove the headcover, chain, sprocket, and lock collar at the top of the upper tube to adjust the two driveshafts.
6. If the chain cover at the discharge end is in place, remove it.
7. Fill the cover half full of grease and lube the chain with chain lube. Reinstall the cover.



**Figure 3.5**

### 3.1.5. DRIVE SHAFT SHIELD & PULLEY GUARD ASSEMBLY

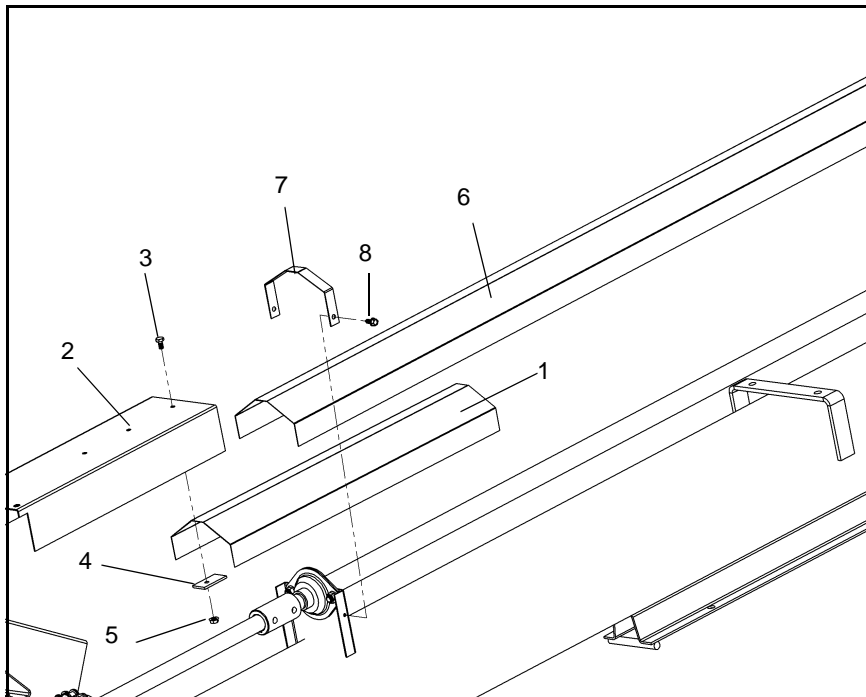
**Note:** See Table 3.3 for shield sizes and quantity. Shield installation starts at the gearbox and ends at the discharge end.

1. Clean dirt and paint from the gearbox shaft and the pulley.

**Note:** Pulley used depends on the power source; refer to “Drive Assembly” on page 36 for the correct pulley selection.

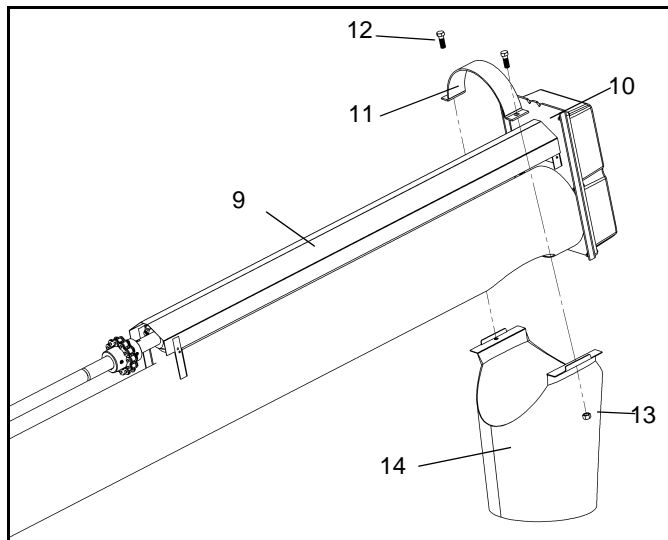
- ➔ **2. North America only:** Install a 1/4” x 1-1/2” square key on the gearbox shaft and slide the pulley, with the hub facing the gearbox, until it is flush with the shaft. Secure by tightening the set screw.
- ➔ **3. North America only:** Attach pulley guard as shown in Figure 3.5 using two 1/2” x 1” bolts, lock washers, and flat washers to mount the pulley guard to the gearbox. Then use one 1/2” x 1” bolt and locknut to attach the pulley guard to the mounting plate.
4. Place the first driveshaft shield over top of the chain connector shield and secure it with a drive guard strap and two self-tapping screws.

**Note:** The driveshaft shield is pinched between the flat iron plate and the connector shield.



**Figure 3.6**

5. The next driveshaft shield (6) is placed on top of the first shield (1) and secured in place with a shield strap (7) and two 1/4” x 5/8” self-tapping screws (8). Repeat until the second last shield is completed.
6. For the last shield (9), see Figure 3.7, secure to the bearing adjustment plate (10) with a shield strap (11) and two 1/4” x 5/8” self-tapping screws (12).
7. Install the discharge spout (14) around the discharge opening using one half clamp (11), two 7/16” x 1-3/4” bolts (12), and two 7/16” locknuts (13).



**Figure 3.7**

**Table 3.3**

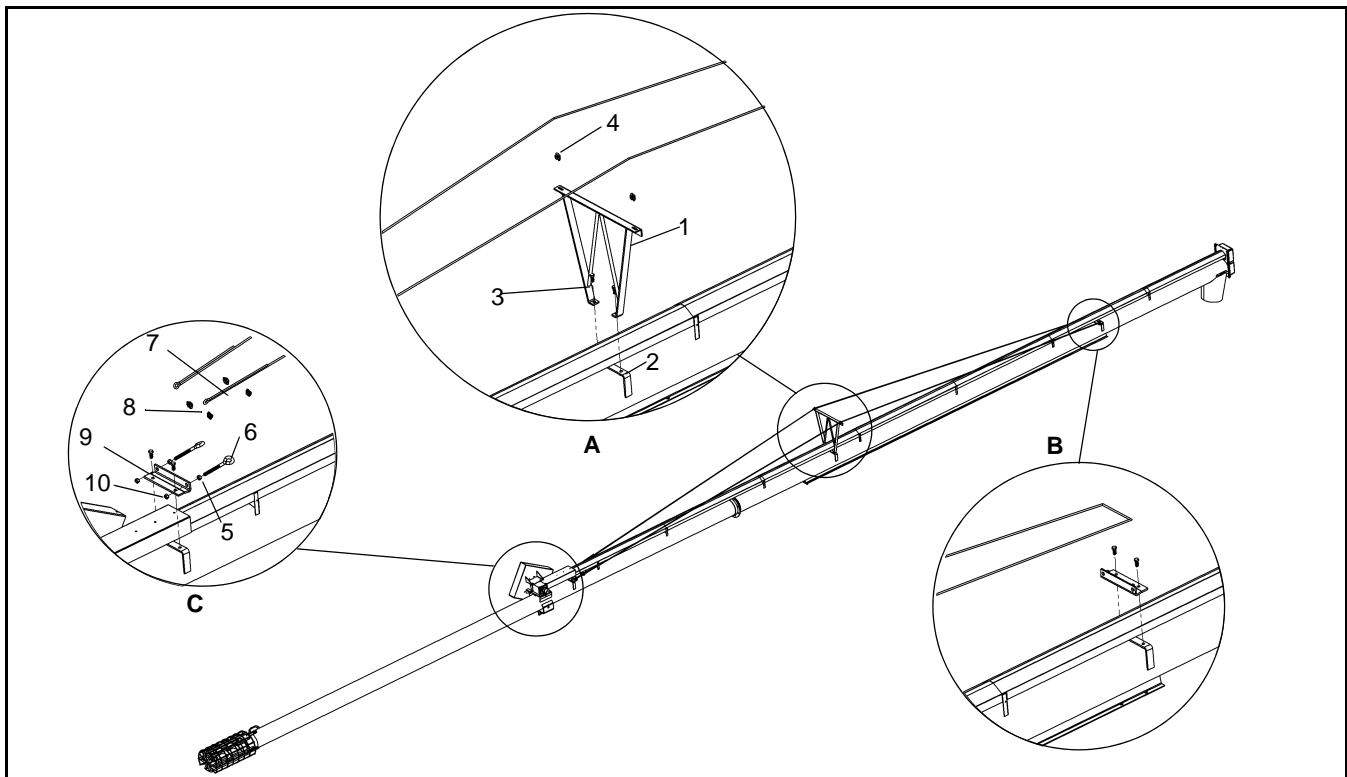
| Model     | Shield Length (Starting at Gearbox) |                 |                     |                 | Total Number of Shields |
|-----------|-------------------------------------|-----------------|---------------------|-----------------|-------------------------|
|           | First                               | Second          | Middle              | Last            |                         |
| TFX2 1051 | 42"<br>(1.07 m)                     | 48"<br>(1.22 m) | 5 @ 60"<br>(1.52 m) | 48"<br>(1.22 m) | 8                       |

## 3.2. TRUSS & CABLE ASSEMBLY

### 3.2.1. BRIDGE/CABLE INSTALLATION & CABLE TIGHTENING

**Note:** Refer to Figure 3.8 for the following instructions.

1. Fasten the cable bridge (1) and truss cable (2) anchors to the tube as shown in Figure 3.8A, using two 7/16" x 1" bolts and 7/16" locknuts. The truss cable anchor bolted nearest the discharge end of the auger should have two rods welded beside the holes to reduce cable wear (Figure 3.8B). The truss cable anchor nearest the intake end will not have these welded features (Figure 3.8C).



**Figure 3.8**

2. Loosely attach two cable clamps (4) on the cable bridge.
3. Thread a jam nut (5) onto an eyebolt (6) all the way. Attach the eyebolt (6) to one end of the truss cable (7) with two 1/4" cable clamps (8), doubling-back about 8" of cable. Insert the eyebolt (6) into the truss cable anchor bracket (9) and thread a 1/2" locknut (10) onto the eyebolt a short way.
4. Pull the truss cable (7) over the cable bridge (1), through the cable clamps, through the holes in the upper cable attach bracket, back over the cable bridge (1), and back to the cable anchor bracket (5).

**Note:** *DO NOT tighten the cable clamps at this time.*

5. Thread a jam nut onto the other eyebolt all the way, place the eyebolt in the cable anchor bracket, and thread on a 1/2" locknut a short way.
6. Thread the end of the truss cable through the eyebolt and pull the cable snug. Double-back the cable and secure in place with two cable clamps as in Step 3.

**Note:** *If there is not enough cable, loosen the clamps on the opposite eyebolt and adjust the cable. Retighten clamps.*

7. Tighten the eyebolts evenly to take the remaining slack out of the truss cable.

**Important:** *Take slack out of the truss cable only, DO NOT tension the cable. Tension in the cable will cause the auger to droop at the flange when in the lowered position.*

8. Check for proper side-to-side alignment and then tighten the cable clamps on the cable bridge and the cable return bracket. Tighten the jam nuts against the cable anchor bracket.



## 3.2.2. LIFT CABLE INSTALLATION

**Note:** The cable on the TFX2 1051 is 49' (14.9 m) long.

1. Attach the cable (1) to the cable attach rod (2) welded to the bottom of the track by wrapping it around the rod and doubling-back about 6" (15 cm) of cable, as shown in Figure 3.9.
2. Secure the cable in place by installing and tightening two cable clamps (3). Refer to Figure 3.9.
3. Thread the cable (4) under the angle iron track stop (6) and through the track shoe (5) as shown in Figure 3.9.
4. Coil the remaining cable and secure it to the tube making sure that the track shoe can slide all the way to the track stop at the discharge end of the track.

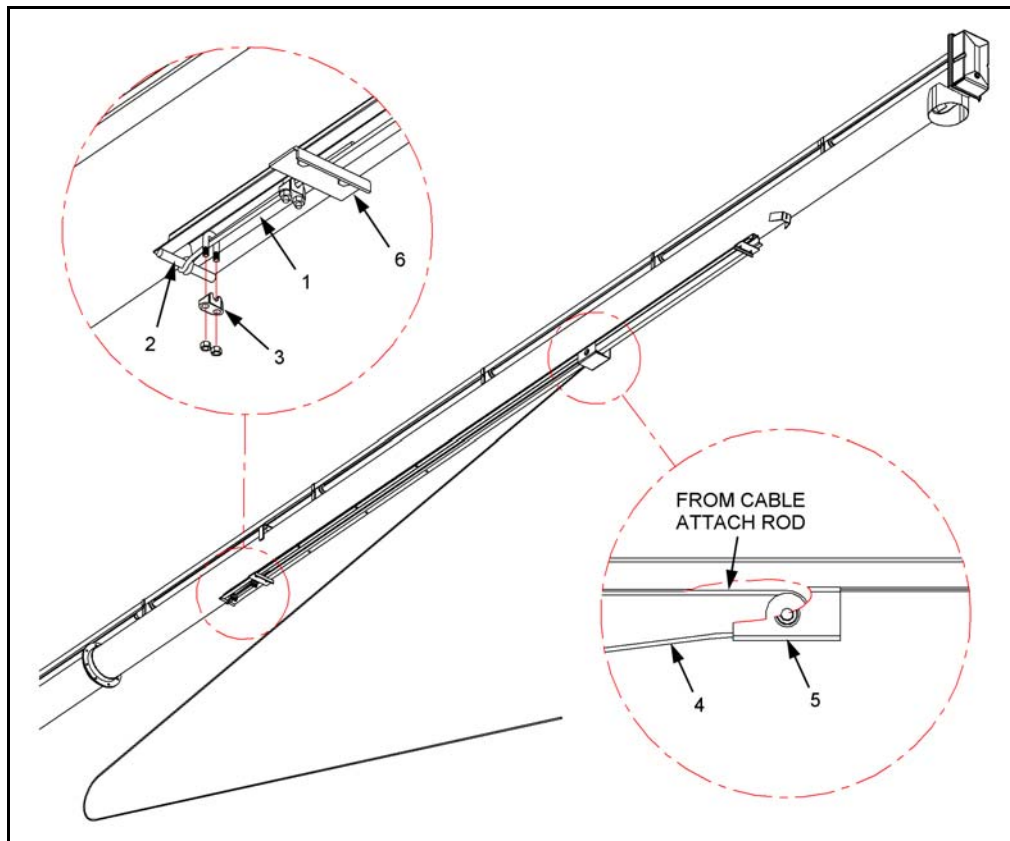


Figure 3.9

## 3.3. WHEEL HUB ASSEMBLY

1. Remove any dirt from spindle and hub.
2. Thoroughly pack wheel bearings and cups with a good grade of bearing grease.
3. Place large bearing into hub and carefully tap in seal.
4. Slip hub onto spindle and insert small bearing.
5. Tighten slotted spindle nut until hub drags slightly. Back off nut about 1/4 turn until hub turns freely.
6. Install cotter pin and dust cap

## 3.4. TIRE ASSEMBLY

**Note:** See Figures 3.10 and 3.11 for tire assembly.

1. Install 15" tires (1) on rims (2) provided. Inflate to 24 psi (165 kPa).

**Note:** Do not exceed the maximum recommended tire pressure for the tire.

2. Mount wheels to hubs (3) using four 1/2" x 1-1/4" wheel bolts (4) per tire.

**Note:** Before mounting the wheels, check to make sure the hub and wheel mounting surfaces are free from rust and debris. Finger tighten the wheel bolts and verify the wheel is sitting flush on the hub. Torque the wheel bolts to 80 ft-lb  $\pm 10$  ft-lb (108.5 Nm,  $\pm 13.5$  Nm) of torque while using the pattern shown below.

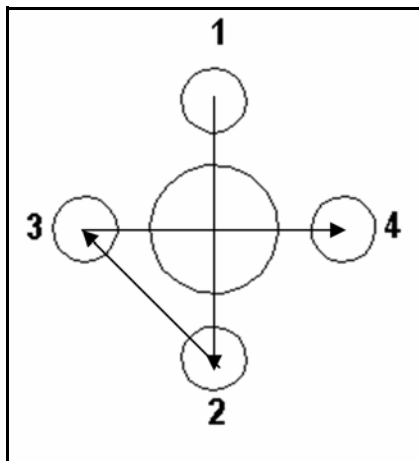



Figure 3.10

| WARNING   |  |
|---|--|
|  | Only properly trained individuals with the proper equipment should attempt to mount the tires as serious injury or death could result. |

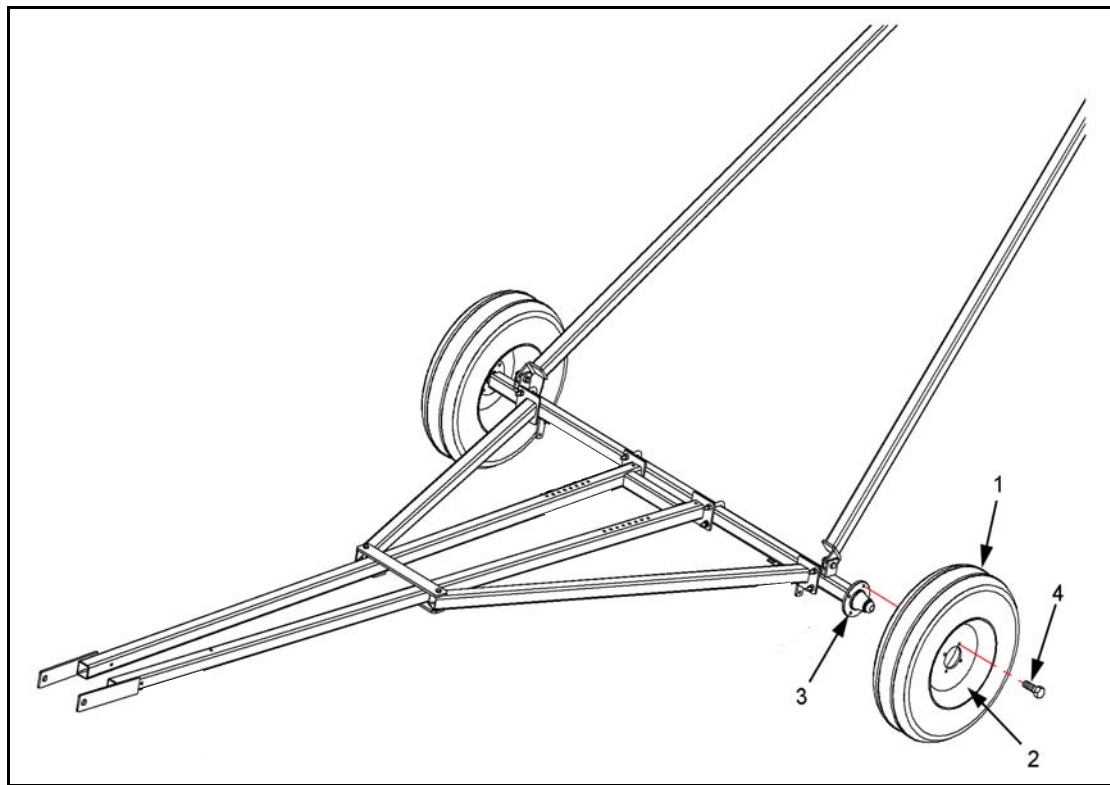


Figure 3.11

## 3.5. FRAME ASSEMBLY

### 3.5.1. LOWER FRAME ASSEMBLY

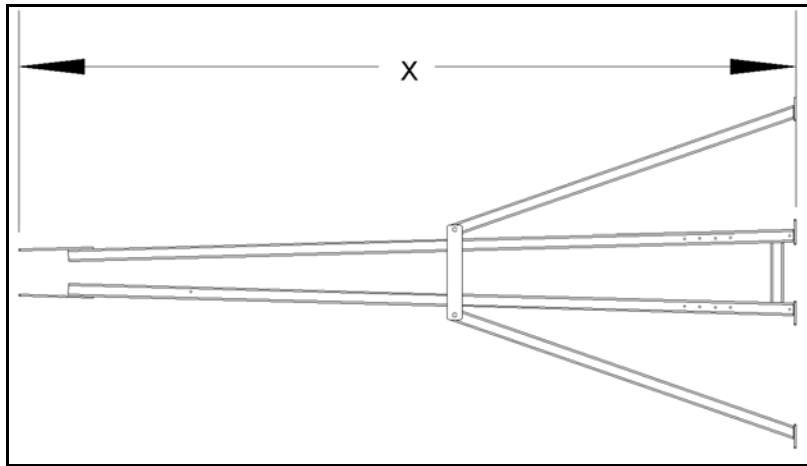
**Note:** See Table 3.4 and Figure 3.12 for the correct frame size.

1. Bolt the outer support arms to the lower frame as shown in Figure 3.11, using one 1/2" x 4" bolt and locknut on each side.
2. Make sure the lower frame (1) and axle (4) are arranged properly. The center crossmember (5) on the lower frame and the double tabs (6) on the axle should be facing up. The gussets (9) on the single tabs under the axle should be closest to the lower frame (1) and intake end of the auger. Refer to Figure 3.14.
3. Center the lower frame on the axle as shown in Figure 3.13. Bolt the lower frame to the axle using four 1/2" u-bolts that fit 2-1/2" square tubing (7) and 1/2" locknuts (8) as shown in Figure 3.14.

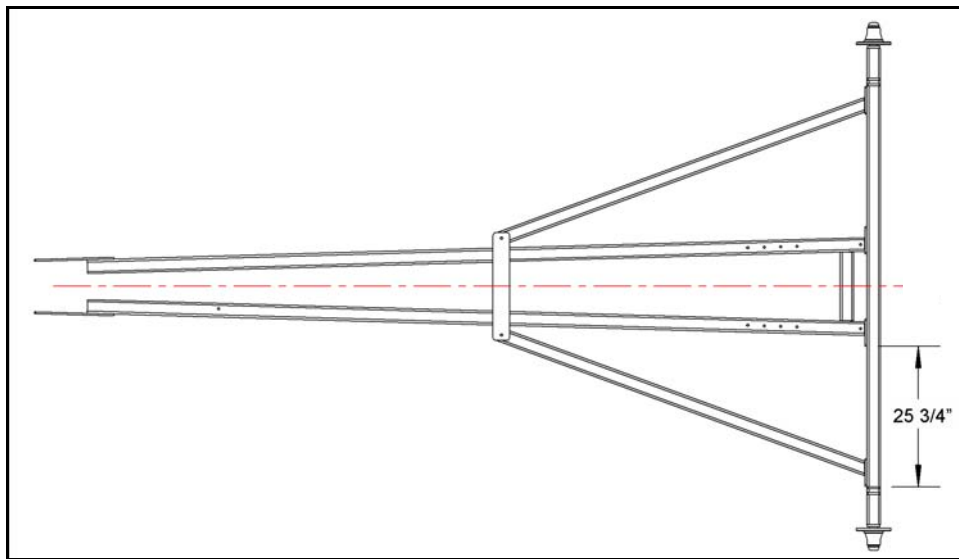
**Note:** The u-bolts for the outer support arms should be to the inside of the lift arm tabs on the axle.

Table 3.4

| Model     | "X"              |
|-----------|------------------|
| TFX2 1051 | 152"<br>(3.89 m) |



**Figure 3.12**



**Figure 3.13 Lower Frame on Axle (Top View)**

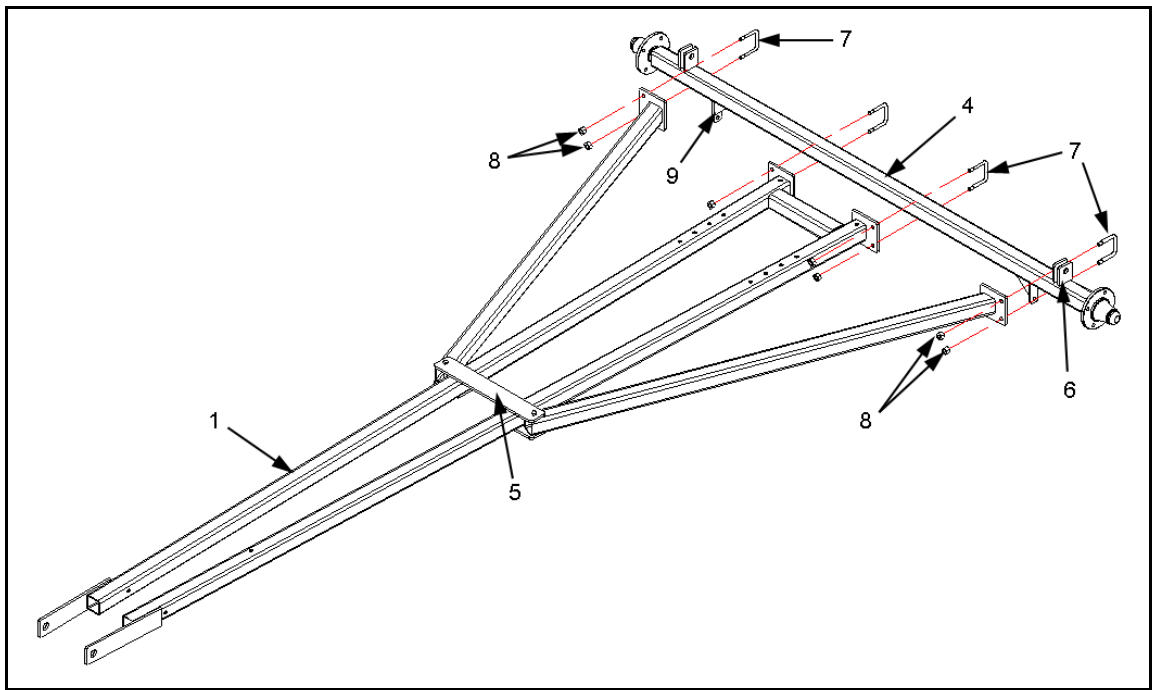


Figure 3.14

### 3.5.2. LIFT ARM ASSEMBLY

**Note:** See Table 3.5 and Figure 3.15 for the correct lift arm size.

1. Bolt the lift arms (3) to the axle (4) using two 3/4" x 2-1/2" bolts (5) and 3/4" locknuts (6). Refer to Figure 3.16.

Table 3.5

| Model     | "W"              |
|-----------|------------------|
| TFX2 1051 | 212"<br>(5.38 m) |

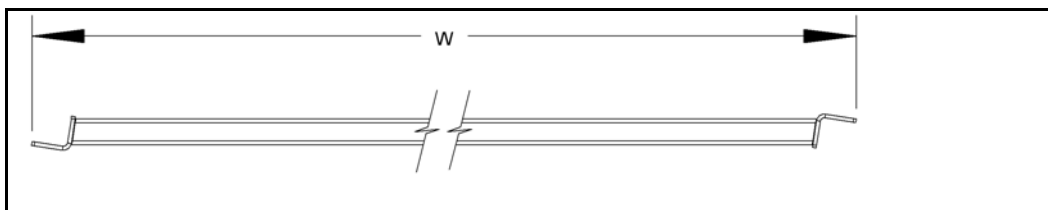


Figure 3.15

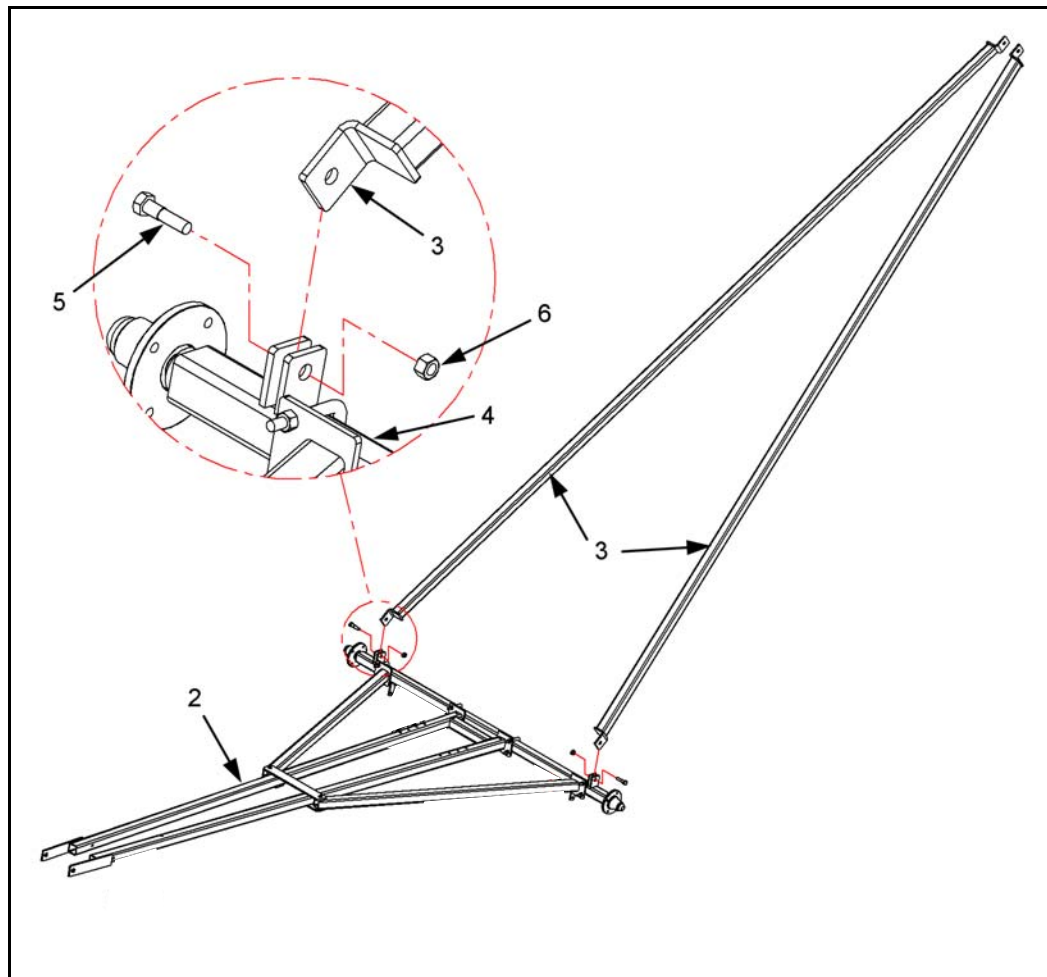


Figure 3.16

### 3.5.3. ATTACHING TO TUBE

**Note:** Refer to Figure 3.18 for following instructions.

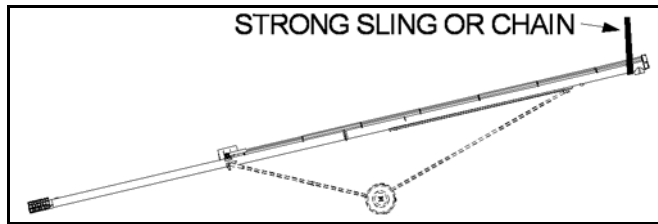
1. Remove the stand from the intake end of the auger tube and raise the discharge end with a block and tackle or a front end loader and a strong sling or chain as shown in Figure 3.17. Height should be sufficient so the frame can be positioned under the tube and the lift arms can be easily attached to the track shoe.

**Important:** Be sure to use proper hoisting equipment and procedures and ensure sling is secured in position. Lock out the hoist apparatus before working around or under the raised tube.

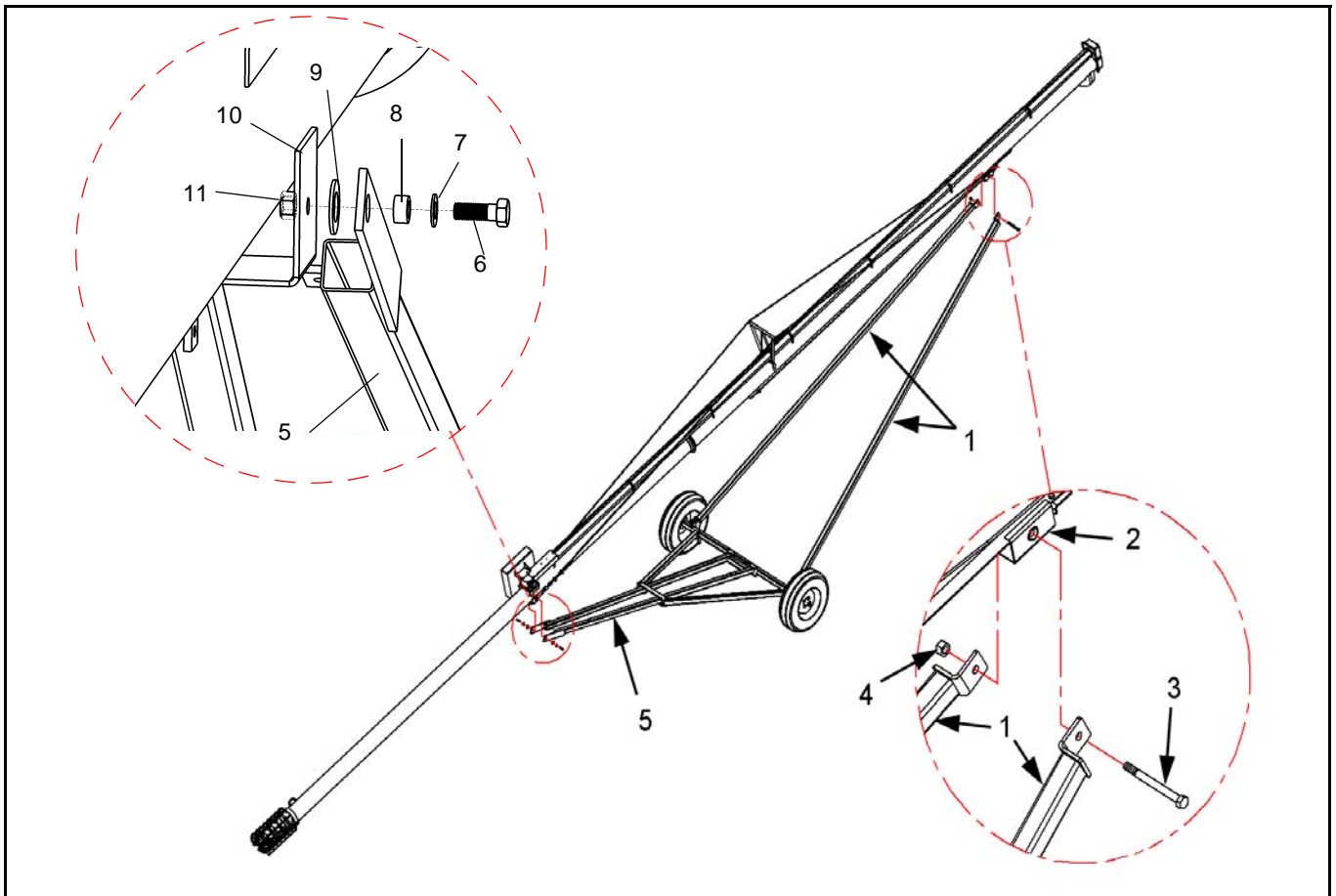
2. Position the frame under the tube assembly.
3. Align the lift arms (1) and the track shoe (2) and attach using a 3/4" x 6-1/2" bolt (3) and 3/4" locknut (4). DO NOT over-tighten. Tighten snug only, this bolt acts as a pivot point.
4. Raise the discharge so the lower frame arms (5) can be aligned with the holes in the tube bracket (10).
5. Attach the lower frame to the bracket on the tube using two 3/4" x 2" bolts (6) on each, then slip in a 3/4" flat washer (7), followed by a 1-1/4" bushing (8).

- Slide the bolts and bushings into the mount holes on the frame and then put a 1-1/4" washer (9) overtop of the bushing. Slide the bolt into the hole in the tube bracket (10) and secure tightly with a 3/4" locknut (11).

**Note:** *The frame arms may need to be spread apart to fit onto the pivot bushings. It might be possible to spread them by hand; if not, a pry bar might be required.*



**Figure 3.17**



**Figure 3.18**

### 3.5.4. CROSS MEMBER / CABLE PULLEY ASSEMBLY

**Note:** Refer to Figure 3.19 for following instructions.

1. Attach pulley mount (20) to auger tabs (21) with 1/2 x 1-1/2 bolts (19) and locknuts (22).
2. Attach the lift arm x-support (1) by sliding it up between the lift arms (2) until it makes firm contact on both sides. Bolt the cross support in place with two 1/2" u-bolts that fit 2-1/2" square tubing (3) and 1/2" locknuts (4).

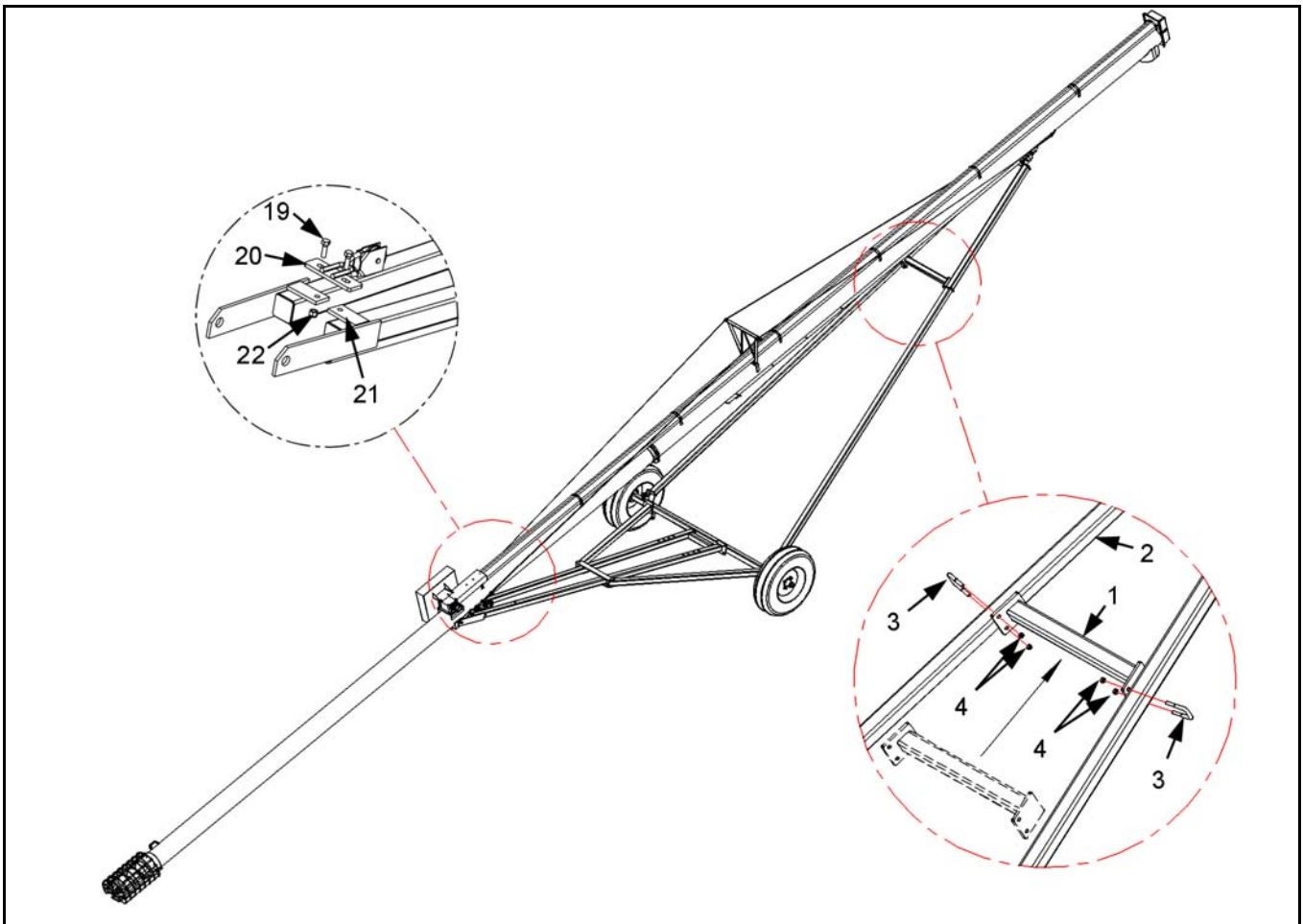


Figure 3.19



### 3.5.5. HAND WINCH ASSEMBLY

1. Assemble the winch (13) and mount plate (14) together with three 3/8" x 1-1/4" bolts (15), 3/8" flat washers (16), and 3/8" locknuts (17), as shown in Figure 3.20.
2. Locate the winch assembly 14" (35.5 cm) from the cross member to the center of the winch drum as shown in Figure 3.20.
3. Loosely secure the winch assembly to the lower frame arm (18) using two 3/8" x 2-1/2" u-bolts (19) and 3/8" locknuts (20) as shown in Figure 3.20.
4. Release the coiled winch cable from the tube. Thread it down around the cable idler from the top and attach it to the winch drum as shown in Figure 3.20.
5. Align the winch assembly with the roller in the track shoe set screw (36'), or with the cable idler, so the cable will index properly on the winch drum when lifting the auger. Secure by tightening nuts (20).

**Note:** Make sure there is a minimum of three wraps on the winch drum when the auger is in the transport position.

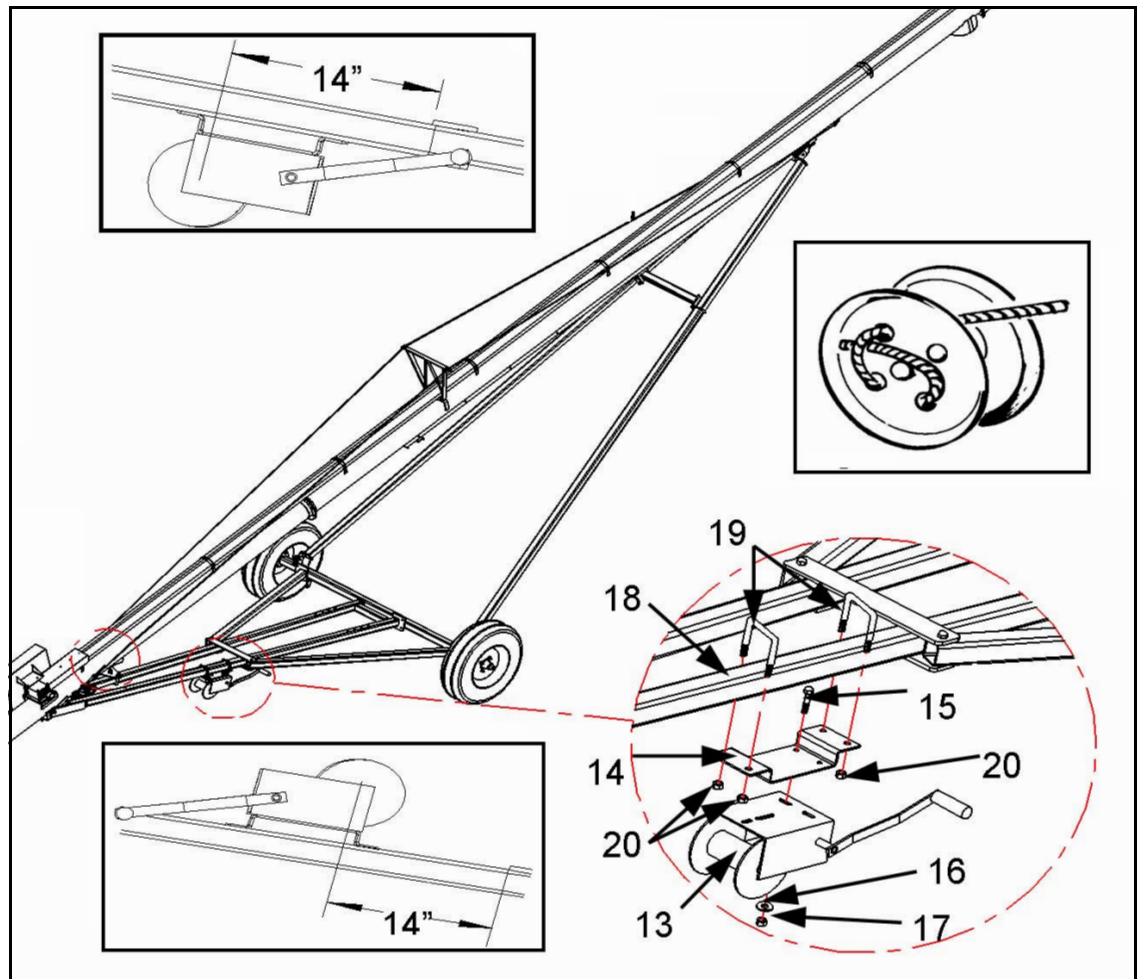


Figure 3.20

### 3.5.6. IDLER ASSEMBLY

#### ➔ NORTH AMERICAN GUARDING ONLY

See “Australian Belt Guard Assembly” on page 44 for Australian guard assembly.

1. Locate the mounting bracket 36" (66 cm) from the lower frame arm pivot as shown in Figure 3.21.
2. Attach the mounting bracket (6) to the lower frame arm (9) using a 3/8" x 2-1/2" u-bolt (10), 3/8" flat washers (11), and 3/8" locknuts (12). DO NOT tighten.
3. Install both belts on gearbox pulley. Take the idler pulley (1) and place it under the back of both belts at point 21 (shown in Figure 3.21).
4. Assemble the idler by attaching the flush side of the idler pulley (1) to the idler guard (2) with a 1/2" x 2-1/2" bolt (3) and 1/2" locknut (4) using a 1/2" flat washer (5) as a spacer (Figure 3.21).

**Note:** DO NOT over-tighten. Pulley must rotate freely.

5. Secure the pulley and guard assembly to the mounting bracket (6) using two 3/8" x 1" bolts (7) and 3/8" locknuts (8). Align the mounting bracket so the idler pulley lines up with the gearbox pulley and tighten.

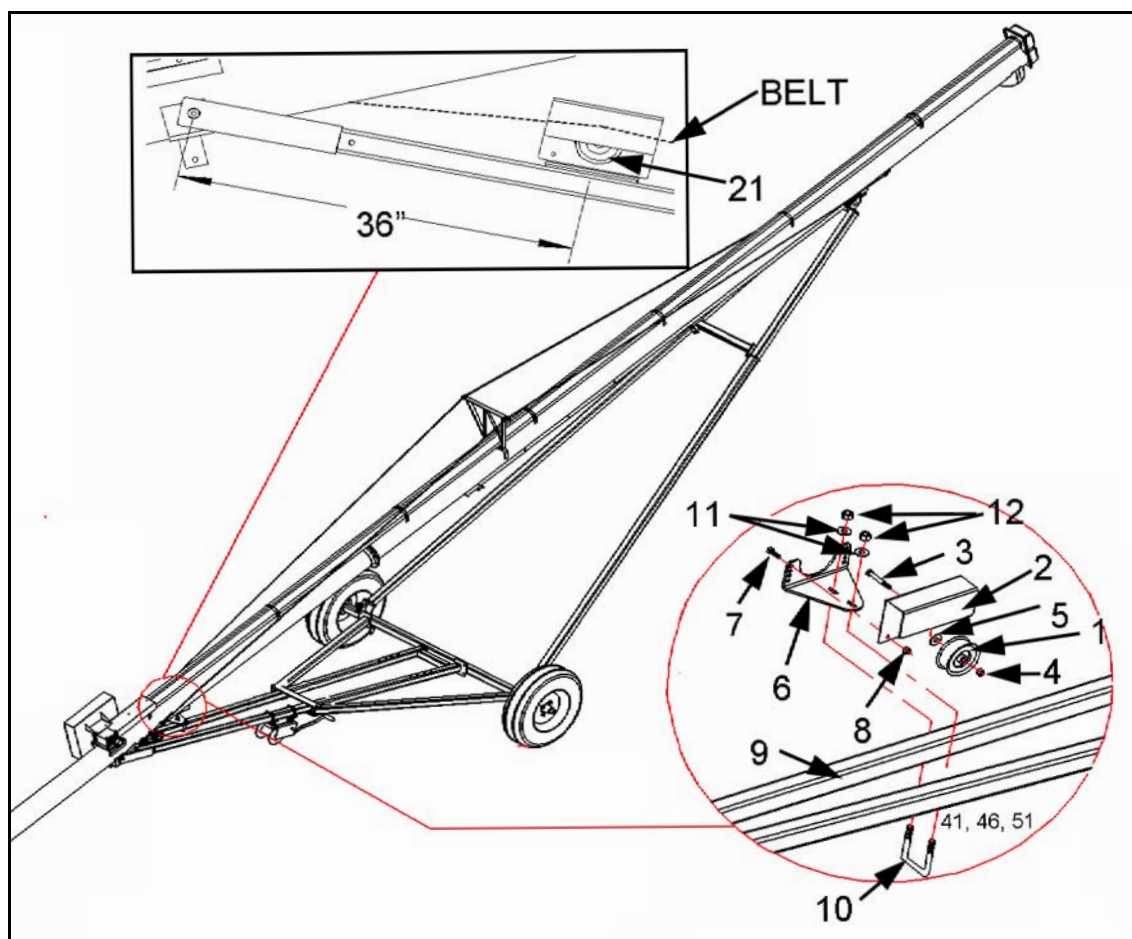
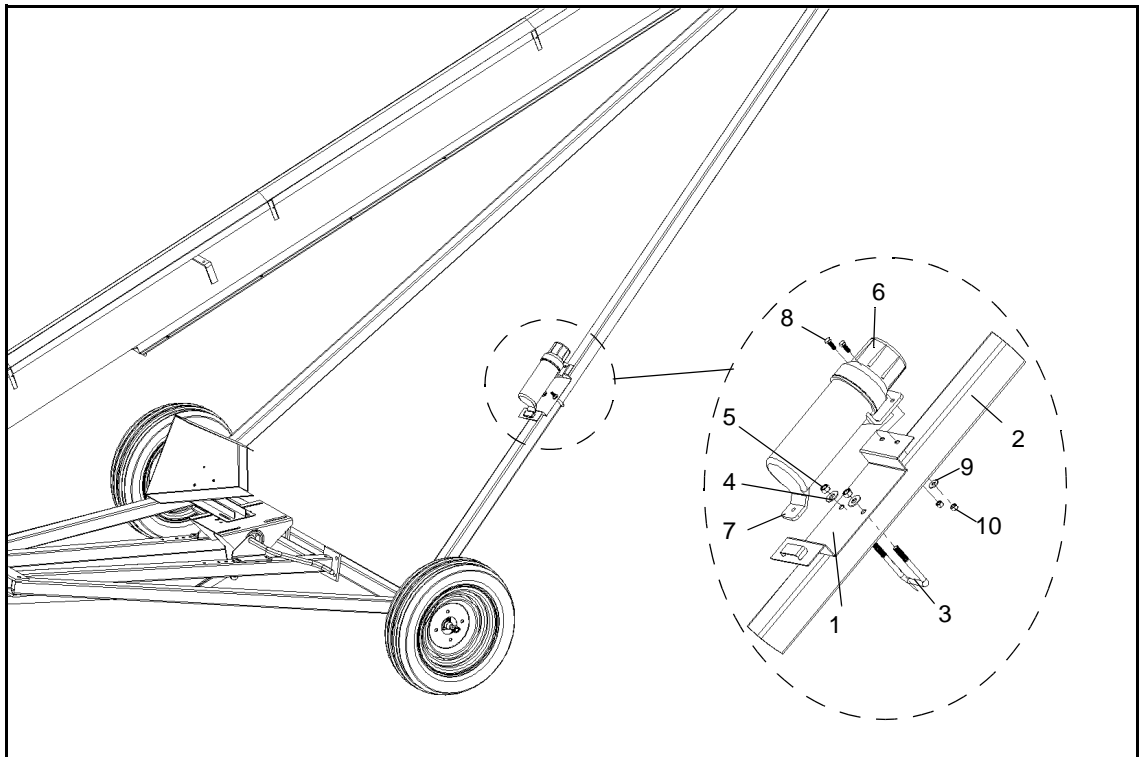


Figure 3.21

## 3.6. PLASTIC MANUAL HOLDER

**Note:** Refer to Figure 3.22 for the following instructions.

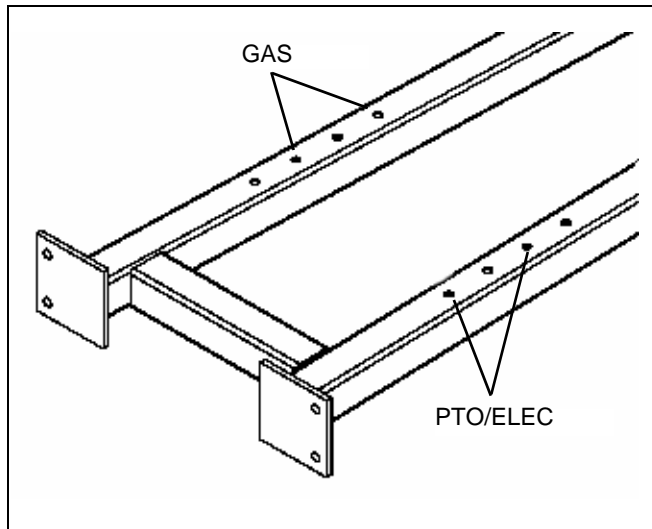
1. Attach manual holder weldment (1) to the upper arm (2) of the auger using one 3/8" x 2-1/2" u-bolt (3) along with two flat washers (4) and locknuts (5).
2. Remove the lid (6) of the manual holder to allow access for the bolts.
3. Slip the tongue (7) on the lower side of the manual holder through the loop on the manual holder weldment. Secure the manual holder to the weldment using two 1/4" x 3/4" bolts (8), washers (9), and locknuts (10).
4. Reinstall the manual holder lid.



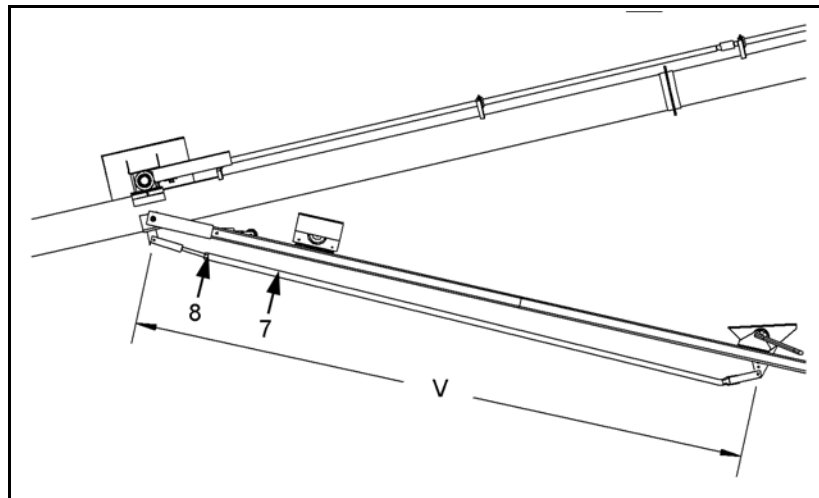
**Figure 3.22**

### 3.7. DRIVE ASSEMBLY

**Note:** *The following figures and tables apply to the gas, electric, and PTO drive assemblies.*



**Figure 3.23**



**Figure 3.24**

**Table 3.6**

| "V" (Leveler Bar Length) |                      |                                 |                      |                      |
|--------------------------|----------------------|---------------------------------|----------------------|----------------------|
| Onan 20                  | Onan 24              | Kohler/<br>Briggs &<br>Stratton | Honda/Robin          | PTO/Electric         |
| 135-1/4"<br>(3.44 m)     | 136-1/4"<br>(3.46 m) | 135-3/8"<br>(3.44 m)            | 134-7/8"<br>(3.50 m) | 132-3/8"<br>(3.36 m) |

### 3.7.1. GAS ENGINE & COMPONENTS

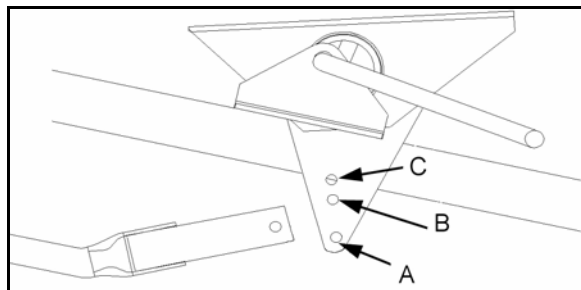
**Note:** Refer to Figure 3.27 (and additional figures and tables where mentioned) for the following instructions.

**Note:** The TFX2 1051 auger with a gas engine uses a 15" triple-groove pulley on its gearbox. See item (46) in Figure 3.27.

1. Slide the bracket (1) onto the over-center handle (2) attached to the motor mount bracket (3). See Figure 3.27.
2. Bolt the brackets to the lower frame arms (4) with four 7/16" x 3-1/2" carriage bolts (5) and 7/16" locknuts (6).

**Note:** Locate the brackets in the proper holes indicated by the arrows in Figure 3.23.

3. Set the length of the leveler bar (7) for the engine specified in Table 3.6. Adjust the nut (8) to change the length. See Figure 3.24.
4. Attach the leveler bar to the pivot bracket tab (9) with a 1/2" x 1-3/4" bolt (10) and 1/2" locknut (11).
5. Locate the proper hole in the motor mount for the engine specified in Table 3.7 and Figure 3.25.
6. Secure the leveler bar (7) to the proper hole with a 1/2" x 1-3/4" bolt (12) and 1/2" locknut (13).



**Figure 3.25**

**Table 3.7**

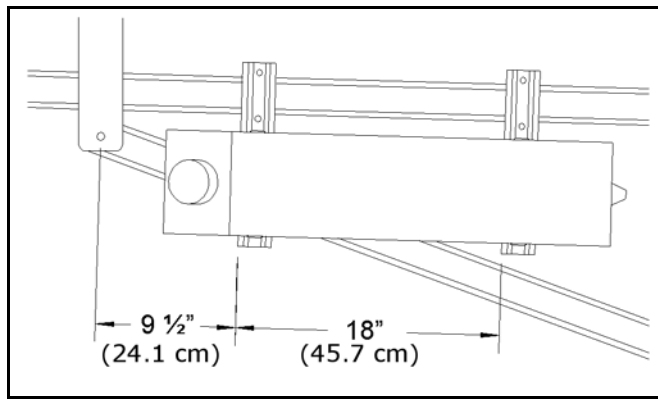
| Onan 20 | Onan 24 | Kohler/Briggs & Stratton | Honda/Robin |
|---------|---------|--------------------------|-------------|
| B       | A       | B                        | C           |

7. Attach the motor pulley guard mount (14) to the motor mount with two 3/8" x 1" bolts (15), 3/8" locknuts (16), and four 3/8" flat washers (17). Do not tighten.



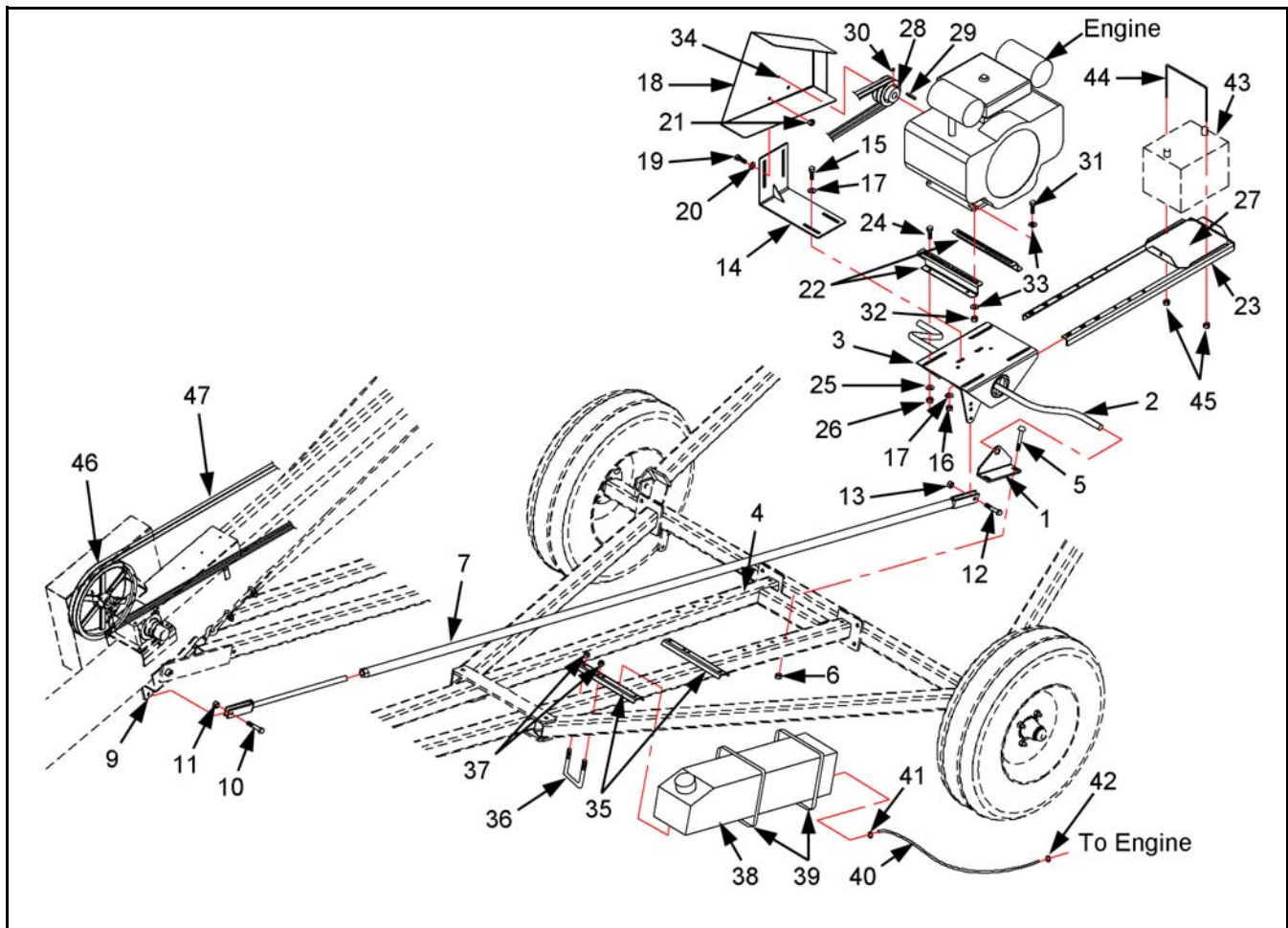
8. **North America only:** Secure the motor pulley guard (18) to the motor pulley guard mount with two 3/8" x 1" bolts (19), 3/8" flat washers (20), and 3/8" locknuts (21). Do not tighten.
9. Place the gas motor mounts (22) on top of the motor mount and orient them as shown in Figure 3.27. Place the battery mount (23) under the motor mount and secure the 3 items together with four 3/8" x 1-1/2" bolts (24), 3/8" flat washers (25), and 3/8" locknuts (26). Do not tighten.

- Note:** *When attaching the battery mount, use the first set of holes and slots closest to the battery holder (27). Different holes may be used depending on the space required for different features of the engine or options on the auger (muffler, mover kit, etc.).*
10. Slide the pulley (28) on the engine's output shaft using a key (29). Tighten the set screw (30) on the pulley once the end of the shaft is flush with the pulley hub.
- Note:** *All engines use a double-groove 4" x 1-1/8" pulley except for the Honda engine, which uses a 4" x 1" pulley.*
11. Place the engine on the gas motor mount brackets (22) and secure in place with four 3/8" x 1-3/4" bolts (31), 3/8" locknuts (32), and eight 3/8" flat washers (33). Do not tighten.
- ➔ 12. **North America only:** Align the engine pulley (46) and gearbox pulley (28) so the v-belts will run straight. Once the pulleys are aligned, tighten the 4 bolts (31) and nuts (32). Check the alignment of the idler pulley and adjust if necessary.
- ➔ 13. **Australia only:** Slide the engine away from the motor mount bracket (3) until the center of the web between the 2 grooves on the pulley (46) is 2-1/8" from the edge of the bracket. Tighten the 4 bolts (31) and nuts (32).
- ➔ **Steps 14.-17. are for North America only:**
14. Install B300 v-belts (47) on the pulleys (28, 46). The center-to-center distance should be 138-1/2" (3.52 m).
15. Using the over-center handle (2), place the motor mount (3) in its working position. Slide the engine towards the discharge until the required center-to-center distance between the engine and gearbox pulleys is obtained. This will ensure proper tension in the belt. Tighten the 4 bolts (24) and nuts (26) to secure the engine.
16. Adjust the height, front-to-back, and side-to-side position of the motor pulley guard so the hole in the center of the motor pulley guard (34) is in the center of the pulley shaft. The guard must be less than 1" from the engine.
17. Tighten the 2 bolts (19), 2 washers (20) and nuts (21) on the motor pulley guard to secure the height of the guard. Tighten the 2 bolts (15), 4 washers (17) and nuts (16) on the motor pulley guard mount to secure the front-to-back and side-to-side position of the guard.
18. Space the tank mount brackets (35) as shown in Figure 3.26. Attach the brackets using two 3/8" u-bolts to fit 2-1/2" square tube (36), and four 3/8" locknuts (37).



**Figure 3.26**

19. Place the gas tank (38) on the brackets and strap it in place using two gear clamps (39).
20. Attach the one end of the 1/4" x 3' hose (40) to the gas tank using a 1/4" hose clamp (41), and attach the other end of the hose to the engine using another 1/4" hose clamp (42).
21. Secure the battery (43) in the battery mount (27) using a 1/4" u-bolt that will fit the battery (44) and two 1/4" locknuts (45).



**Figure 3.27**

## 3.7.2. ELECTRIC MOTOR & COMPONENTS

---

**Note:** Refer to Figure 3.28 (and additional figures and tables where mentioned) for following instructions.

**Note:** A double-groove 13" sheave is used on the gearbox for electric motors; see item (46) in Figure 3.28.

1. Slide the bracket (1) onto the over-center handle (2) attached to the motor mount bracket (3).
2. Bolt the brackets to the lower frame arms (4) with four 7/16" x 3-1/2" carriage bolts (5) and 7/16" locknuts (6).

**Note:** Locate the brackets in the proper holes indicated by the arrows in Figure 3.23.

3. Set the length of the leveler bar (7) for the electric motor specified in Table 3.6. Adjust the nut (8) to change the length. See Figure 3.24.
4. Attach the leveler bar to the pivot bracket tab (9) with a 1/2" x 1-3/4" bolt (10) and 1/2" locknut (11).
5. Locate the proper hole in the motor mount as specified in Figure 3.25. Use hole "B" to mount the leveler bar to the motor mount.
6. Secure the leveler bar (7) to the proper hole with a 1/2" x 1-3/4" bolt (12) and 1/2" locknut (13).
7. Attach the motor pulley guard mount (14) to the motor mount with two 3/8" x 1" bolts (15), 3/8" locknuts (16), and four 3/8" flat washers (17). Do not tighten.
8. Secure the motor pulley guard (18) to the motor pulley guard mount with two 3/8" x 1" bolts (19), 3/8" flat washers (20), and 3/8" locknuts (21). Do not tighten.
9. Place the electric motor mounts (22) on top of the motor mount and orient them as shown in Figure 3.28. Secure with four 3/8" x 1" bolts (24), 3/8" flat washers (25), and 3/8" locknuts (26). Do not tighten.
10. Slide the pulley (28) on to the motor's output shaft using a key (29). Tighten the set screw (30) on the pulley once the end of the shaft is flush with the pulley face.

**Note:** All electric motors use a double-groove 8" pulley.

11. Place the motor on the electric motor mounts and secure it in place with four 3/8" x 1" bolts (31), 3/8" locknuts (32), and eight 3/8" flat washers (33). Do not tighten.
12. Align the electric motor pulley (28) and the gearbox pulley (46) so the v-belts will run straight. Once the pulleys are aligned, tighten the 4 bolts (31) and nuts (32). Check alignment of the idler and pulley, and adjust if necessary.
13. Install B300 v-belts (47) on the pulleys (28,46).
14. Slide the electric motor towards the discharge end using the over-center handle so there is adequate tension on the belt when the motor is engaged. Tighten the 4 bolts (24) and nuts (26) to secure the motor.
15. Adjust the height, front-to-back, and side-to-side position of the motor pulley guard so the hole in the center of the motor pulley guard (34) is in the center of the pulley shaft. The guard must be less than 1" from the motor.



16. Tighten the 2 bolts (19) and nuts (21) on the motor pulley guard to secure the height of the guard. Tighten the 2 bolts (15) and nuts (16) on the motor pulley guard mount to secure the front-to-back and side-to-side position of the guard.

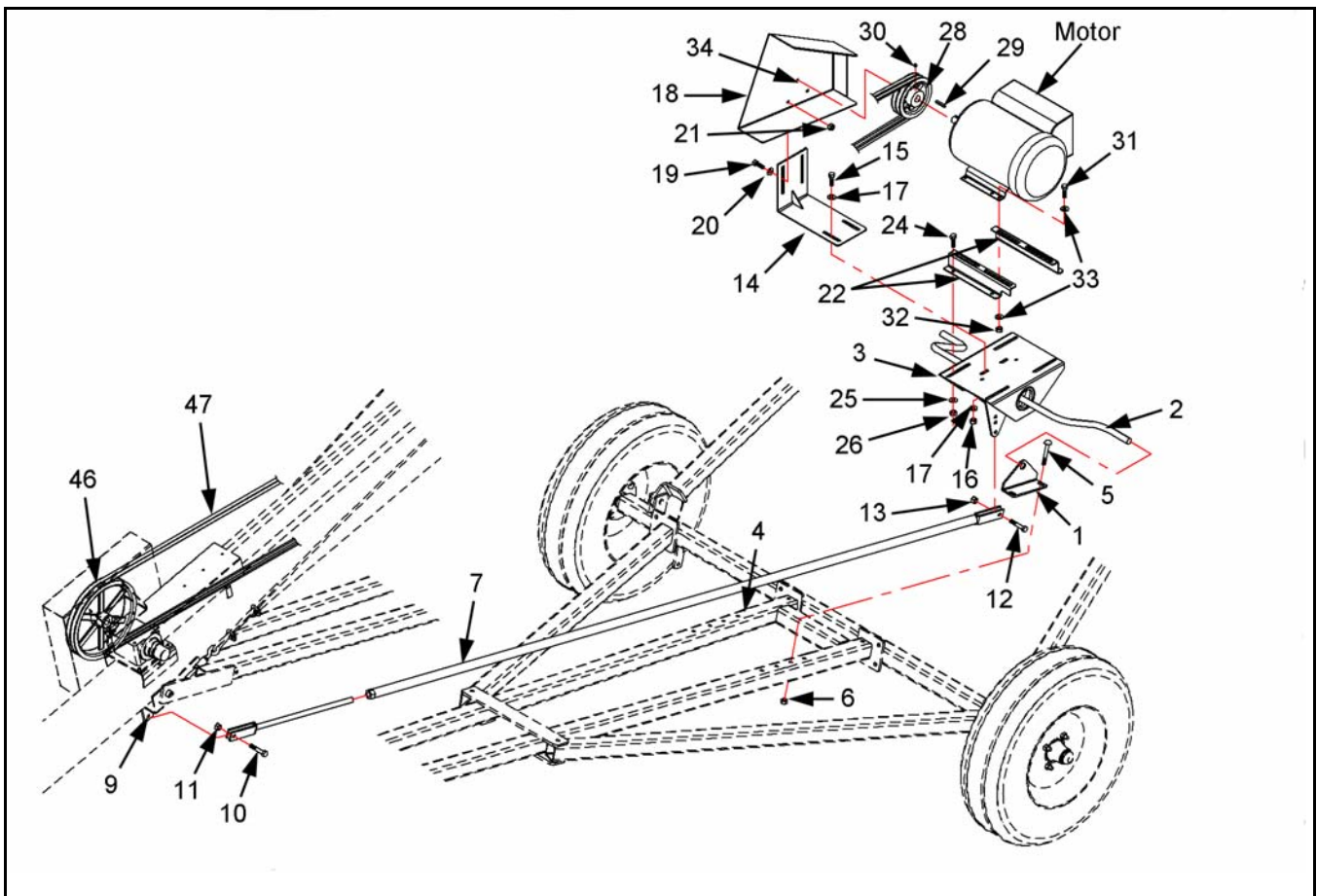


Figure 3.28

### 3.7.3. PTO & COMPONENTS

**Note:** Refer to Figure 3.29 (and additional figures and tables where mentioned) for following instructions.

**Note:** A double-groove 8" sheave is used on the gearbox for PTO driven augers; see item (47) in Figure 3.29.

1. Slide the bracket (1) onto the over-center handle (2) attached to the motor mount bracket (3).
2. Bolt the brackets to the lower frame arms (4) with four 7/16" x 3-1/2" carriage bolts (5) and 7/16" locknuts (6).

**Note:** Locate the brackets in the proper holes indicated by the arrows in Figure 3.23.

3. Set the length of the leveler bar (7) for a PTO driven auger as specified in Table 3.6. Adjust the nut (8) to change the length. See Figure 3.24. Attach the leveler bar to the pivot bracket tab (9) with a 1/2" x 1-3/4" bolt (10) and 1/2" locknut (11).
4. Use hole "B" in Figure 3.25 to mount the leveler bar to the motor mount.

5. Secure the leveler bar (7) to the proper hole with a 1/2" x 1-3/4" bolt (12) and 1/2" locknut (13).
6. Attach the PTO mount (14) to the motor mount with four 3/8" x 1" bolts (15), 3/8" locknuts (16), and 3/8" flat washers (17). Do not tighten.
7. Slide the 2 pillow block assemblies (18) onto the jackshaft (19) with the locking collars facing in. Slide the jackshaft through the hole in the PTO mount (20), and secure the pillow blocks to the PTO mount with four 1/2" x 1-1/2" bolts (21), 1/2" flat washers (22), and 1/2" locknuts (23).
8. Slide the pulley (24) on to the jackshaft with a key (25) using the inside groove (26). Do not tighten.

**Note:** *PTO driven augers use a double groove 13" x 1" input pulley.*

9. Align the PTO pulley (24) with the gearbox pulley(47) so the belts will run straight. Adjust both the position of the jackshaft in the pillow blocks and the position of the pulley on the jackshaft to properly align. Tighten both locking collars on the pillow blocks and the set screw (27) on the pulley.
10. Secure the PTO shaft shield (28) in place with two 1/2" x 1" bolts (29) and 1/2" locknuts (30).
11. Install B300 v-belts (46) on the pulleys (24, 47). Check alignment of the idler and pulley, and adjust if necessary.
12. Slide the PTO mount towards the discharge end using the over-center handle so there is adequate tension on the belt when the PTO is engaged. Tighten the 4 bolts (15) and nuts (16) to secure the PTO.
13. Bolt the PTO front shield (31) to the PTO mount using four 3/8" x 3/4" bolts (32) and 3/8" lock washers (33).
14. Install the PTO rubber flap (34) onto the PTO front shield with the PTO rubber mount strap (35), two 5/16" x 3/4" bolts (36), and 5/16" locknuts (37).
15. Secure the PTO transport saddle (38) to the lower frame arms with a 3/8" u-bolt that fits 2-1/2" HSS (39) and two 3/8" locknuts (40).
16. Install the 60" PTO driveline (41) onto the jackshaft with a key (42), and tighten the set screw to secure (43).
17. Place the driveline in the transport saddle and secure it with the PTO pin (44) and hairpin (45).

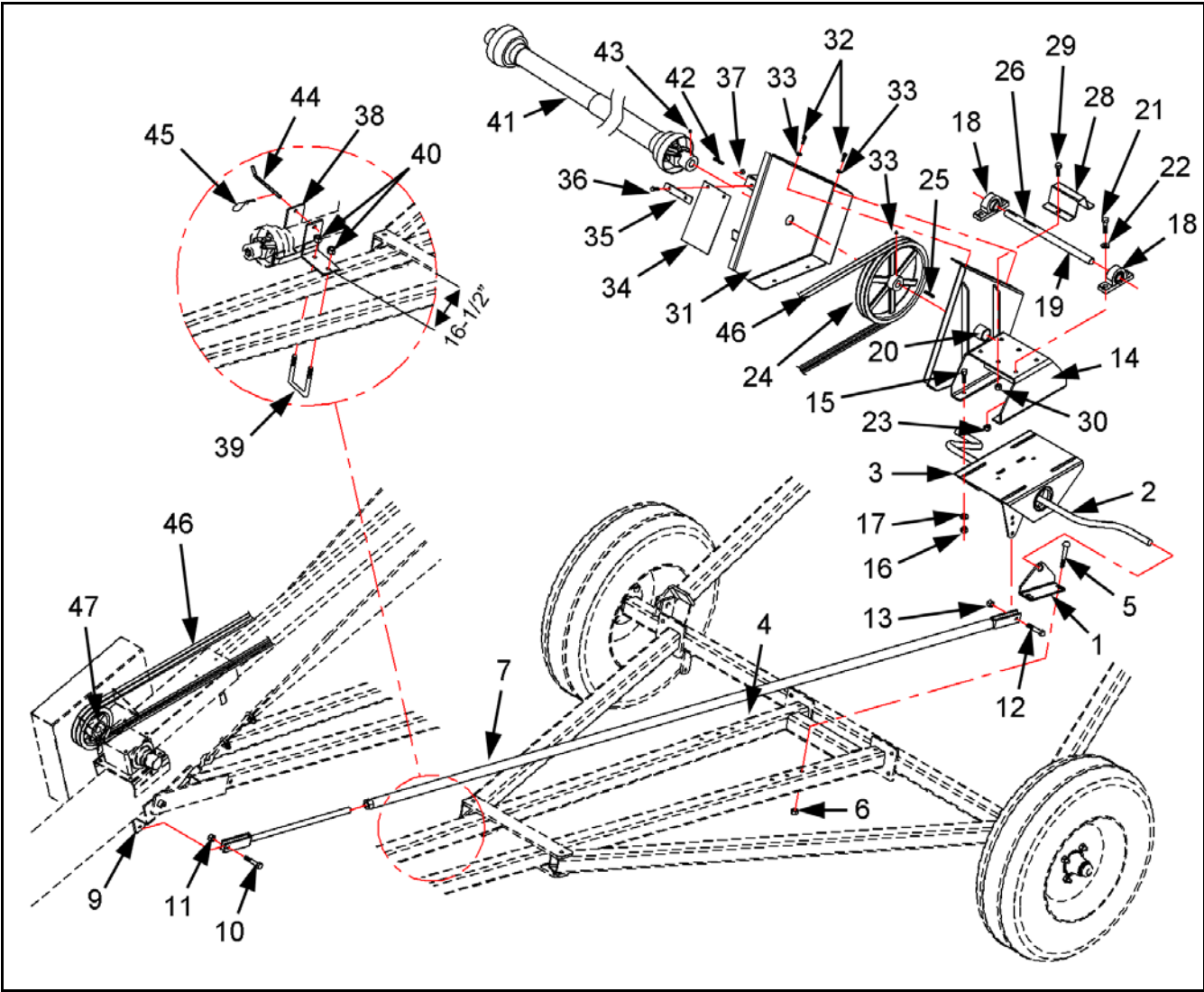
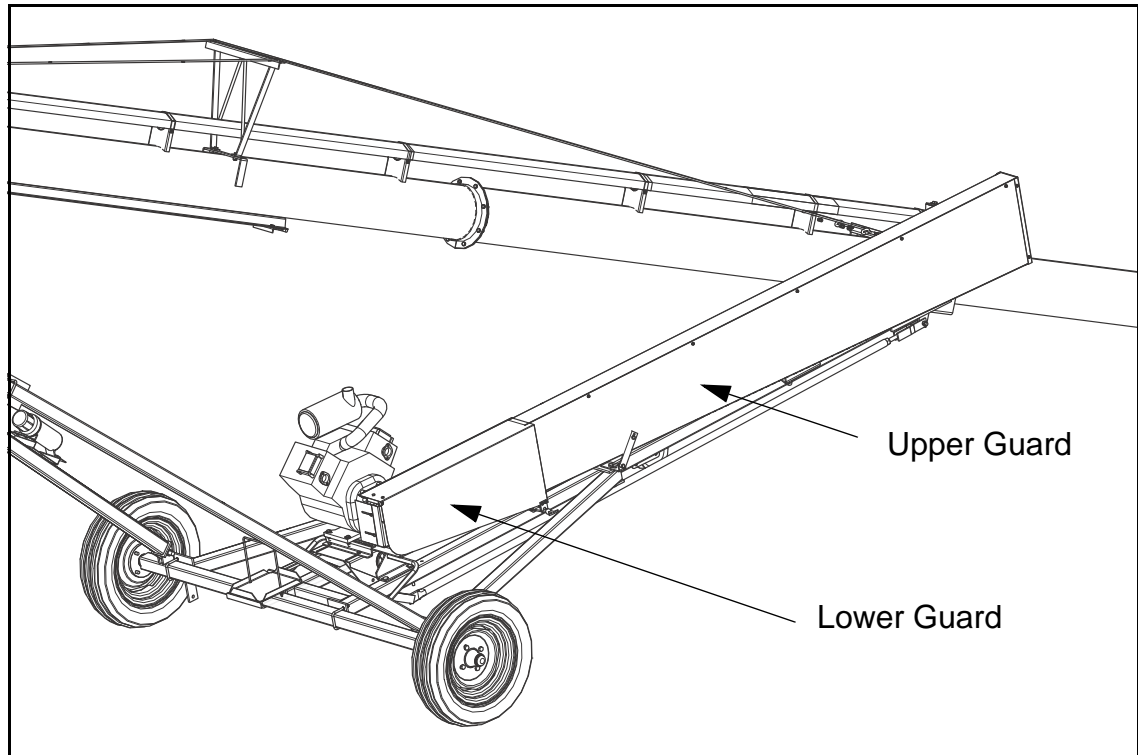


Figure 3.29

### 3.7.4. AUSTRALIAN BELT GUARD ASSEMBLY

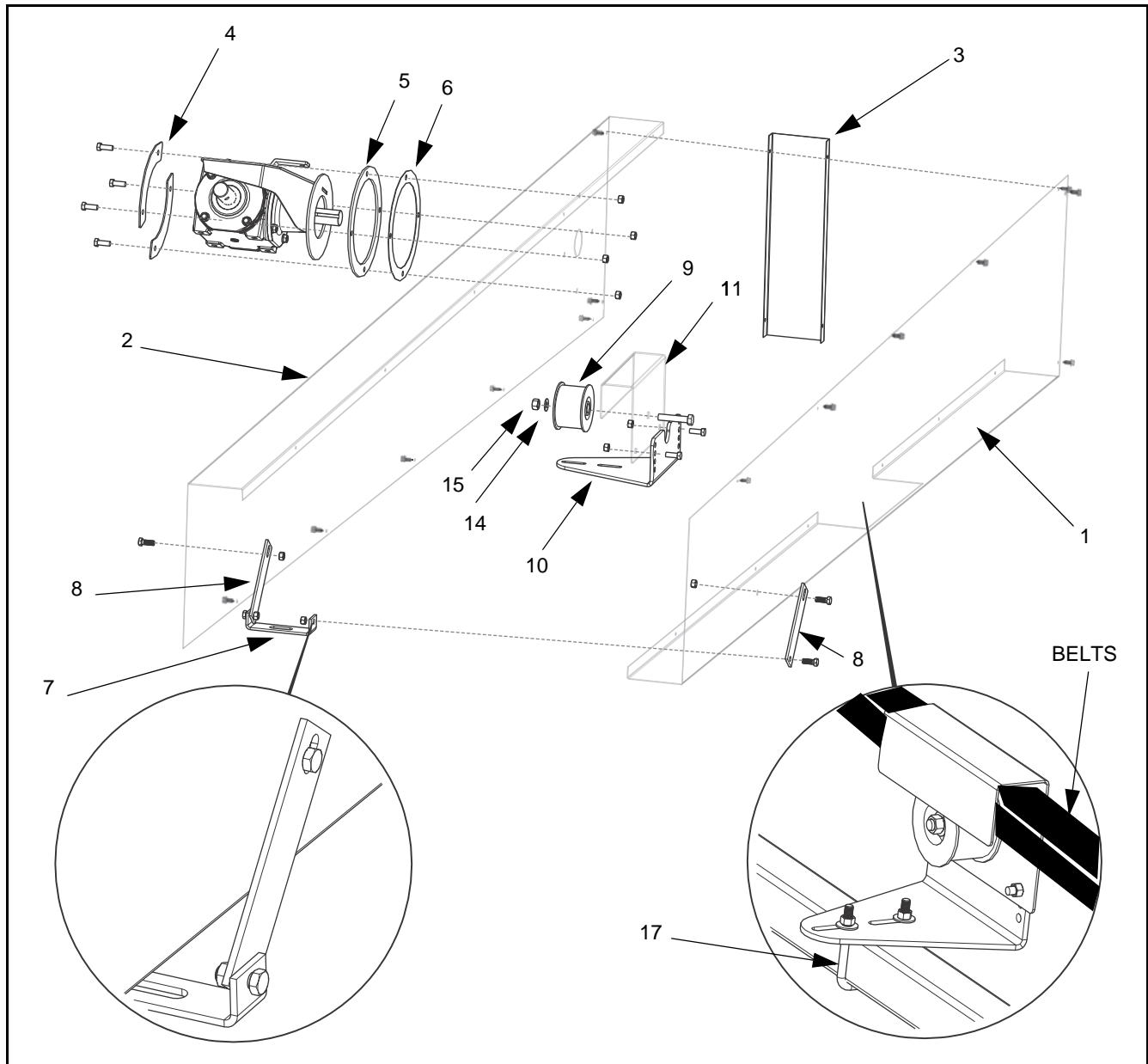
When installing the Australian Belt Guard, assemble the upper guard first, and then assemble the lower guard. See Figure 3.30 for the assembled upper and lower guards.



**Figure 3.30 Australian Belt Guard (Upper and Lower Sections)**

## UPPER BELT GUARD

**Note:** See Table 3.8 and Figure 3.31 for the upper guard assembly.



**Figure 3.31 Upper Belt Guard Assembly**

1. Attach a linkage plate (8) to the inside of the linkage mount (7) using two 3/8" x 1" bolts and locknuts. The bolt should be loose enough to allow the plates to pivot.
2. Connect the inner belt guard (2) to the gearbox, ensuring that the gearbox mount supports (4), gearbox mount stabilizer (5), and the gearbox mount shim (6) are properly placed. Use 3/8" x 1" bolts and locknuts to fasten the inner belt guard to the gearbox.
3. Using a 3/8" x 1" bolt and locknut, attach a linkage plate (8) to the inner belt guard (2), ensuring that the connection is loose enough to allow the linkage to pivot.

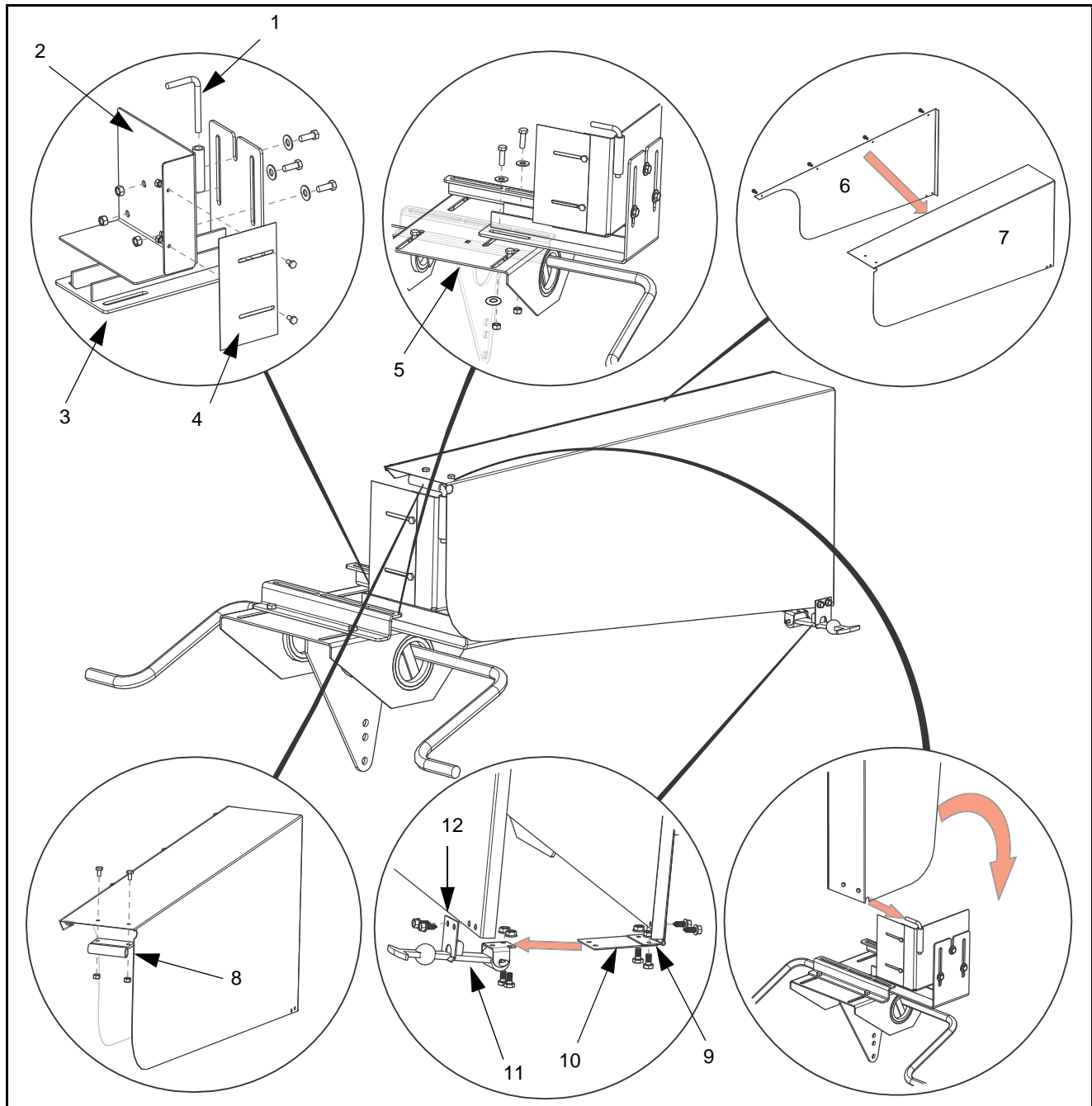
**Table 3.8 Upper Belt Guard Parts**

| Item | Part No. | Description                | QTY |
|------|----------|----------------------------|-----|
| 1    | 10-20125 | UPPER OUTER BELT GUARD     | 1   |
| 2    | 10-20126 | UPPER INNER BELT GUARD     | 1   |
| 3    | 10-20122 | UPPER BELT GUARD END COVER | 1   |
| 4    | 4508034  | GEARBOX MOUNT SUPPORT      | 2   |
| 5    | 4508035  | GEARBOX MOUNT STABILIZER   | 1   |
| 6    | 4508036  | GEARBOX MOUNT SHIM         | 1   |
| 7    | 4503317  | LINKAGE MOUNT              | 1   |
| 8    | 10-20121 | LINKAGE PLATE              | 2   |
| 9    | 29890    | IDLER PULLEY               | 1   |
| 10   | 10-20124 | IDLER BASE                 | 1   |
| 11   | 10-20123 | IDLER GUARD, 3-belt        | 1   |
| 12   | ---      | 3/8" x 1" BOLT             | 10  |
| 13   | ---      | 3/8" LOCKNUT               | 10  |
| 14   | ---      | 1/2" x 2-1/2" BOLT         | 1   |
| 15   | ---      | 1/2" FLAT WASHER           | 1   |
| 16   | ---      | 1/2" LOCKNUT               | 1   |
| 17   | ---      | 3/8" x 2-1/2" U-BOLT       | 1   |
| 18   | 19274    | SELF TAPPING SCREWS        | 16  |

4. Install the sheave on the gearbox shaft with the long hub facing inward, and tighten set screws.
5. Install B300 belts onto the gearbox and engine pulleys. It may be necessary to over-center the motor mount to install the belts. The center-to-center distance should be 138-1/2" (3.52 m) when in the working position.
6. Assemble the idler around the belts as shown in Figure 3.31, ensuring that during assembly the belts are contained between the idler pulley and the idler guard:
  - a. Bolt the idler guard (11) to the idler base plate (10) using two 3/8" x 1" bolts and locknuts inserted through the second bolt holes from the top of the idler base plate.
  - b. Connect the idler pulley (9) to the idler guard (11) using a 1/2" x 2-1/2" bolt, 1/2" washer, and 1/2" locknut.
7. Fasten the idler base (10) to the frame member running under the guards with the u-bolt, ensuring that the idler is positioned within the space provided by the gap in the bottom of the outer belt guard (1).
8. Attach a linkage plate (8) to the outer guard (1) using a 3/8" x 1" bolt and locknut, ensuring that the connection is loose enough to allow the linkage to pivot.
9. Attach the outer belt guard (1) to the inner belt guard (2) with 1/4" x 5/8" self-tapping screws.
10. Attach the outer linkage plate (8) to the inside of the linkage mount (7) using two 3/8" x 1" bolts and locknuts. The bolt should be loose enough to allow the plates to pivot.
11. Attach the belt guard end cover (3) using four 1/4" x 5/8" self-tapping screws as shown in Figure 3.31.
12. Install the lower belt guard. See "Lower Belt Guard" on page 47.

## LOWER BELT GUARD

**Note:** See Table 3.9 and Figure 3.32 and for the lower guard assembly.



**Figure 3.32 Lower Belt Guard Assembly**

1. Place the belt guard pivot arm (1) through the pipe on the belt guard connector plate (2).
2. Mount the connector plate (2) onto the belt guard support bracket (3) using two 3/8" x 1" bolts, locknuts, and washers. The hole in the center of the connector plate (2) should be lined up with the center of the slot in the support bracket (3) and the same vertical height as the engine shaft.
3. Using two 1/4" x 1/2" bolts and locknuts, mount the belt guard cover plate (4) to the belt guard connector plate (2). Slide the cover plate (4) as close to the engine as possible. **DO NOT** over-tighten screws.

**Table 3.9 Lower Belt Guard Parts**

| ITEM | Part No. | Description                         | QTY |
|------|----------|-------------------------------------|-----|
| 1    | 4503310  | LOWER BELT GUARD PIVOT ARM          | 1   |
| 2    | 4503309  | LOWER BELT GUARD CONNECTOR PLATE    | 1   |
| 3    | 4503041  | LOWER BELT GUARD SUPPORT BRACKET    | 1   |
| 4    | 4503324  | LOWER BELT GUARD COVER PLATE        | 1   |
| 5    | ---      | MOTOR MOUNT BRACKET                 | 1   |
| 6    | 4503323  | LOWER INNER BELT GUARD              | 1   |
| 7    | 4503322  | LOWER OUTER BELT GUARD              | 1   |
| 8    | 4503311  | LOWER BELT GUARD PIVOT              | 1   |
| 9    | 4503286  | 2" HINGE                            | 1   |
| 10   | 4503325  | 16 GA x 2" x 3" PLATE               | 1   |
| 11   | 4503327  | RUBBER SAFETY STRAP, 2-1/2", SINGLE | 1   |
| 12   | 4503326  | RUBBER STRAP CATCH                  | 1   |
| 13   | ---      | 3/8" x 1" BOLT                      | 5   |
| 14   | ---      | 3/8" FLAT WASHER                    | 7   |
| 15   | ---      | 3/8" LOCKNUT                        | 5   |
| 16   | ---      | 1/4" x 5/8" SELF-TAPPING SCREWS     | 8   |
| 17   | ---      | 1/4" x 1/2" BOLTS                   | 8   |
| 18   | ---      | 1/2" LOCKNUTS                       | 8   |

4. Slide the belt guard support bracket (3) into position on the motor mount bracket (5), and bolt it in place with two 3/8" x 1" bolts, flat washers (at bolt head and at nut), and locknuts.
5. Fasten the belt guard pivot (8) on the inside of the outer belt guard (7) using two 1/4" x 1/2" bolts and locknuts.
6. Attach the inner belt guard (6) to the outer belt guard (7) using four 1/4" x 5/8" self-tapping screws.

**Note:** *Bolt package is for both the lower and upper guard assembly.*

7. From the bolt package, assemble the guard latch on the inner and outer belt guards:
  - c. fasten the 2" hinge (9) to the inner belt guard (6) using two 1/4" x 5/8" self-tapping screws
  - d. Mount the catch (12) for the rubber strap (11) on the outer belt guard (7) with two 1/4" x 5/8" self-tapping screws.
  - e. Fasten the 2" x 3" galvanized plate (10) between the rubber strap (11) and the 2" hinge (9) using four 1/4" x 1/2" bolts and locknuts. Bend the cotter pin over to retain the rubber strap in place.
8. Adjust engine position by sliding the engine mount z-brackets. This will ensure proper belt tension. Adjust the belt guard support bracket (3) so the outside face is 5-7/8" (14.9 cm) away from the motor mount bracket (5) face and the center slot is aligned horizontally with the shaft center on the engine. Tighten bolts.
9. Hold the inner and outer belt guard assembly in a vertical position, and slide the belt guard pivot (8) onto the pivot arm (1). Swing the inner and outer belt guard assembly into place, and close the latch by stretching the rubber strap into place.



## 3.8. DECAL INSTALLATION

### 3.8.1. DECAL PLACEMENT

**Important:** Do not cover any existing safety or instruction decals with the model decals.

1. Apply decals to both sides of auger tube.

**Note:** Decals should be easily visible from the ground when auger assembly is complete.

2. Apply the Westfield model decal (3) between the 2nd and 3rd bearing mount from the discharge end and center it vertically on the tube as shown in Figure 3.33.
3. Position the “Manufactured By” decal (4) 60” (152 cm) from the flange on the lower section and center it on the tube as shown in Figure 3.33.

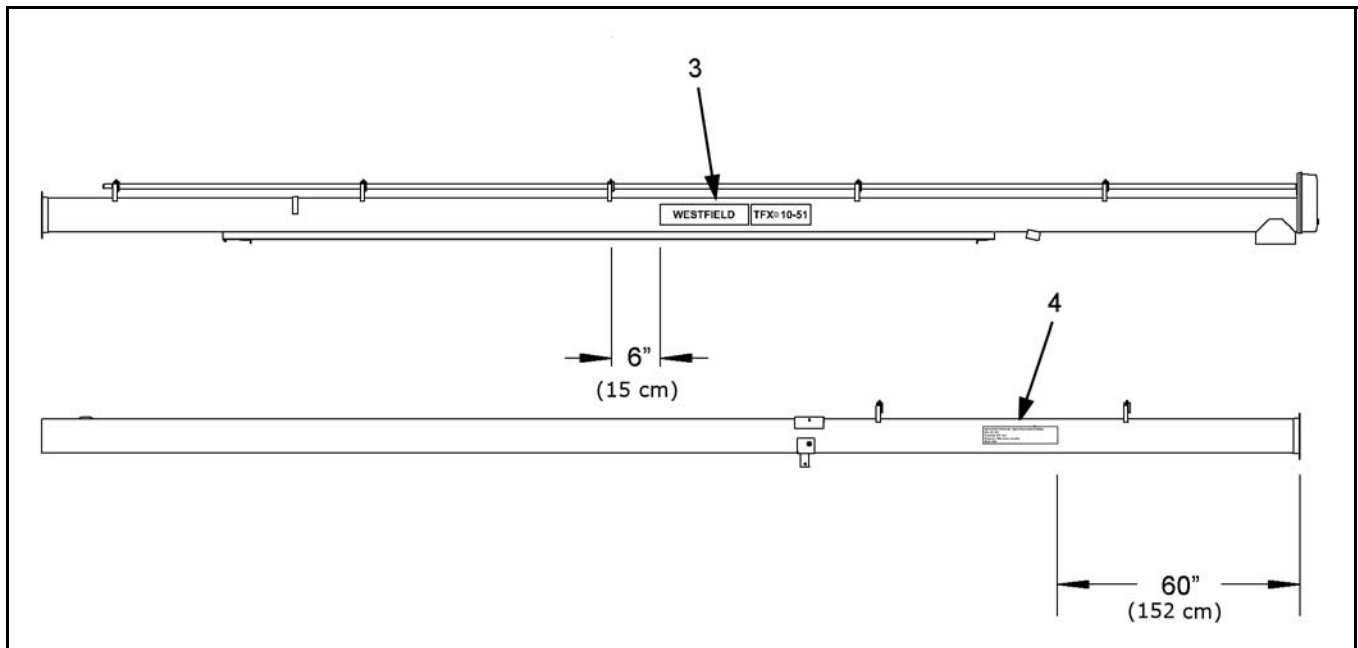



Figure 3.33



# 4. Transport & Placement


**WARNING** Before continuing, ensure you have read and understand the relevant information in the safety section. Safety information is provided to help prevent serious injury, death, or property damage.

## 4.1. TRANSPORT PROCEDURES

| <b>DANGER</b>   |  |
|---|--|
|  | <p><b>Electrocution hazard:</b></p> <ul style="list-style-type: none"><li>• This auger is not insulated.</li><li>• Keep auger away from overhead power lines and devices.</li><li>• Electrocution can occur without direct contact.</li><li>• Fully lower auger before moving.</li></ul> <p>Failure to keep away will result in serious injury or death.</p> |

| <b>NOTICE</b>   |  |
|---|--|
| <p>Empty the auger before transporting. Transporting a full auger will place excessive loads on the tube assembly, frame, axle assembly, hitch, and towing unit.</p> <p>If auger wheels are partially or fully buried in snow or grain, do not attempt to move auger until snow or grain has been cleared away from auger wheels.</p> |  |


### WHEN TRANSPORTING:

| <b>WARNING</b>  |   |
|---|---|
|  | <p>Failure to secure the unit prior to transporting could cause a serious hazard to the occupants of the towing vehicle or of other vehicles.</p> |


To reduce the risk of injury or death to people using this equipment, follow basic safety precautions:

- Ensure tires are inflated to the tire manufacturers' recommended pressure.
- Check with local authorities regarding transportation of agricultural equipment on public roadways. Obey all applicable laws and regulations.
- Make sure that all lights and reflectors required by law are in place, functioning, and can be seen by all overtaking and oncoming traffic.

- Ensure the unit is hitched securely to the towing vehicle.
- Display a SMV (slow moving vehicle) emblem when transporting slower than 25 mph (40 km/hr). Never transport faster than road, terrain, or conditions will allow you to safely.

| <b>WARNING</b>  |   |
|---|---|
|  | <p>A vehicle imbalance between the towing vehicle and the machine could reduce your vehicle's stability, handling, and braking ability, and could lead to an upset or collision.</p> <p>Transport at a speed that road conditions allow, to a maximum speed of 20 mph (32 km/h)</p> |

- Take special care and precautions when transporting during times of limited visibility such as rain, snow, fog, dusk, or at night. It is recommend that you wait for a more appropriate time to move.
- Use hazard-warning lights when transporting with a tractor, unless prohibited.
- Keep to the right and yield the right-of-way to allow faster traffic to pass.
- Use caution when turning corners or meeting traffic.
- Be aware of height limiting objects.
- Do not transport the auger on a slope greater than 20°. The auger may over-turn.

| <b>DANGER</b>   |  |
|---|--|
|  | <p>Upending Hazard:</p> <p>Do not raise auger intake above tow bar height.</p> <p>Empty auger and lower fully before moving.</p> <p>Failure to do so will result in serious injury or death.</p> |

The Wheatheart auger is designed to be easily and conveniently readied for transport. Follow this procedure when converting the machine from operating to transport configuration.

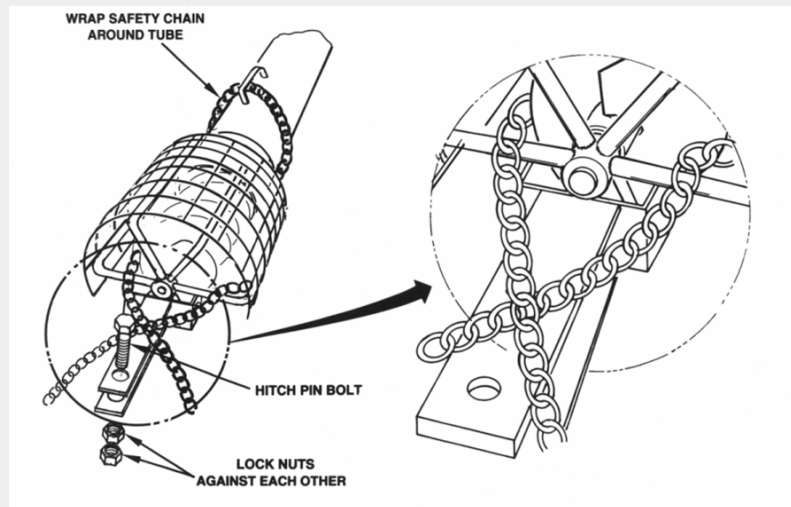
1. Make sure work area is clear of any obstructions before lowering.
2. Connect the auger to the towing vehicle and use a retainer to lock the hitch draw pin in place.
3. Place the belts under tension.
4. Remove all wheel chocks.
5. Lower the auger until the roller track shoe is resting on the down position stop, and there is slight tension on the lift cable.
6. Lock the winch into place by turning the handle clockwise until 2 clicks are heard.

7. Place the PTO driveline in the transport saddle and secure (PTO drive only).
8. Install the safety chain between the auger and the frame of the towing unit.

**Important:** *The chain must have a load rating at least as high as the auger weight.*

### SAFETY CHAIN

- The safety chain should be threaded through the handle on the lower tube, and wrapped around the auger tube before attaching to the towing vehicle.
- The loop should form a cradle that will prevent the auger from digging into the road surface or upsetting, should a breakaway occur.
- Ensure there is no more slack in the chain than required for turning.
- When not in use, store the safety chain in a clean, dry place. Replace the safety chain if one or more links or end fittings are broken, stretched, or otherwise damaged, or deformed.



### CAUTION



After lowering auger, always turn winch handle clockwise at least 2 clicks to tighten brake lock.

Maintain control of winch handle at all times.


Maintain light cable tension when in towing position.

Do not put lubrication on brake disc.

Check cable before each use and replace if frayed or damaged.

Make certain that cable clamps are securely tightened.

## 4.2. PLACEMENT PROCEDURES

| <b>DANGER</b>   |  |
|---|--|
|  | <p><b>Electrocution hazard:</b></p> <ul style="list-style-type: none"><li>• This auger is not insulated.</li><li>• Keep auger away from overhead power lines and devices.</li><li>• Electrocution can occur without direct contact.</li><li>• Fully lower auger before moving.</li></ul> <p>Failure to keep away will result in serious injury or death.</p> |

When placing the auger, follow these instructions and see Figure 4.1.

1. Check for power lines or any obstructions that may damage the auger.
2. Move the machine under the truck or storage facility.
3. Place the auger on a firm, level surface.
4. Chock the wheels before augering any products.
5. Always use a vehicle or mover to move the auger. Never move it by hand.
6. Do not place anything under the wheels to add height to the auger.
7. To prevent upending or the wind upsetting the auger: when operating the auger in raised position, rest the discharge end on the bin roof or tie it down to the bin. When operating the auger in a free-standing position, anchor the intake end.

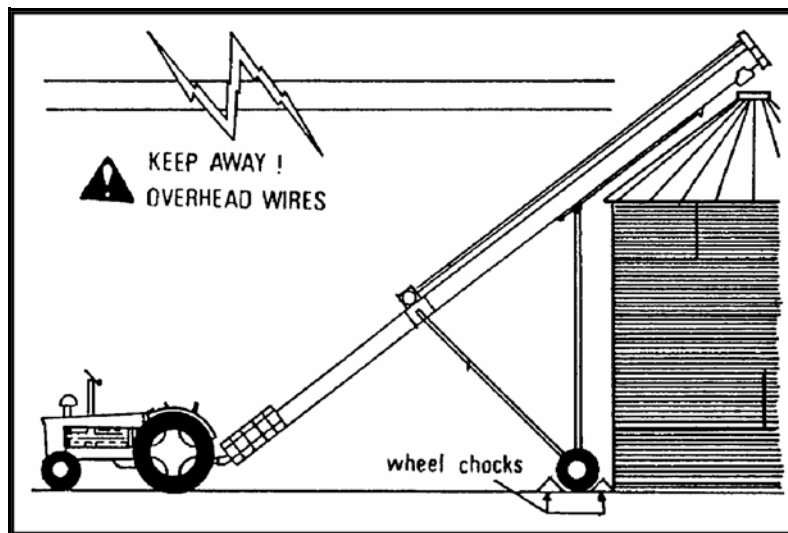


Figure 4.1

# 5. Operation

**WARNING** Before continuing, ensure you have read and understand the relevant information in the safety section. Safety information is provided to help prevent serious injury, death, or property damage.

## 5.1. COMPONENTS & CONTROLS

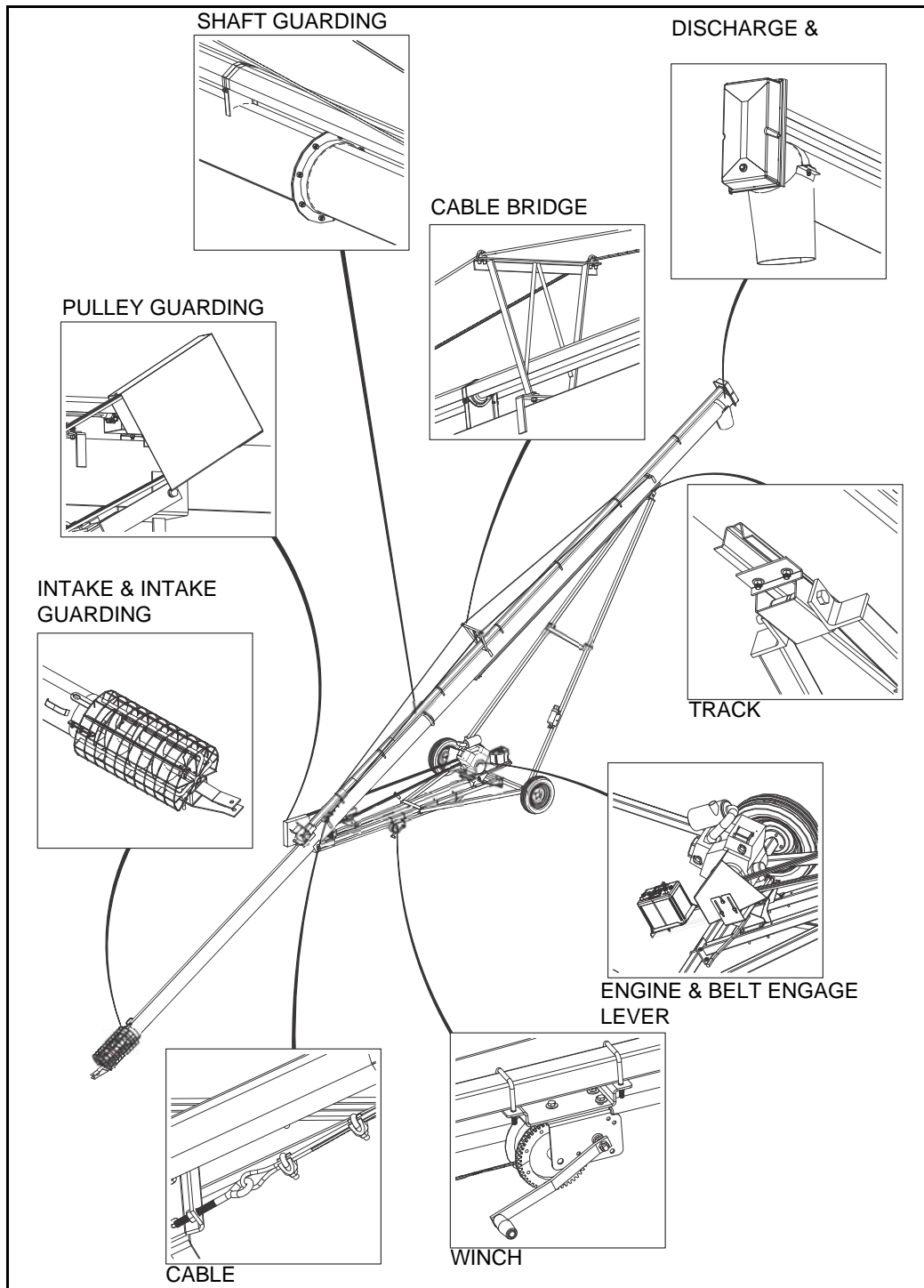


Figure 5.1 Gas Model Shown (Electric and PTO Models Not Shown)

## 5.2. AUGER DRIVE & LOCKOUT

---

Correct operation of the Westfield auger requires pre-inspection of the drive system, operator knowledge on how to shut down the system, and a general monitoring of the system during operation.

### 5.2.1. GAS ENGINE

---

#### DRIVE SYSTEM

Before starting the motor, ensure that:

1. The gas tank is properly closed.
2. The belt release is disengaged so that the belts are released from the motor pulley.
3. The area surrounding the auger is properly ventilated.
4. Pulley shields are in place and secure.

#### LOCKOUT

1. Shut down and lock out power source.
2. For engines with a rope or crank start, remove the spark plug wire or the spark plug. For engines with an electric start, remove the ignition key, the spark plug wire, or the spark plug.

### 5.2.2. ELECTRIC MOTOR

---

#### DRIVE SYSTEM

Before starting the motor, ensure that:

1. The motor is properly grounded.
2. The belt release is disengaged so that belts are released from motor pulley.
3. Pulley shields are in place and secure.

#### LOCKOUT

1. The electric motor should be equipped with a main power disconnect switch capable of being locked in the off position only. The switch should be in the locked position during shutdown or whenever maintenance is performed on the auger.
2. If reset is required, disconnect all power before resetting motor.

### 5.2.3. PTO DRIVELINE

---

#### DRIVE SYSTEM

1. Ensure that the PTO driveline is securely attached to the tractor and jackshaft.
2. Do not use PTO driveline without a rotating shield in good working order.



3. Do not exceed the maximum operating angle of 15°.
4. Be sure that the PTO-drive on the tractor is in the off position before starting tractor.
5. Stay clear of the PTO hazard area.

### **LOCKOUT**

1. Shut off engine.
2. Remove ignition key from tractor.
3. If step 2 is impossible, remove the PTO driveline from tractor.

## **5.3. OPERATING PROCEDURES**

---

### **5.3.1. BREAK-IN PERIOD**

---

Your auger does not require an elaborate break-in. However, following a few simple tips during the first 1000 bu of operation can add to the reliability and life of your machine.

If any unusual noises or vibrations are encountered, determine the source, shut the auger off, lock out the power source, and adjust. If unsure of the problem, or the procedure to fix it, contact your local Westfield dealer.

#### **PRE-OPERATIONAL CHECKLIST:**

- Read the power source operation manual.
- Inspect motor mounting bolts for tightness.
- Check oil level in the gear box by removing the filler plug. Make sure the gear box is half full (center cross shaft) and free of foreign objects.
- Inspect all belts for alignment, tightness, and abnormal wear. Adjust or replace as required.
- Inspect components for damage and abnormal wear. Replace as required.
- Check that safety decals are installed and legible. Apply new decals if required.
- Check the wheel bolt torque prior to transporting the unit. See “Bolt Torque Values” on page 73 for recommended torque values.
- Check that tires are inflated to the manufacturer’s recommended pressure prior to transporting the unit.
- Check the upper chain drive tension and alignment.

Please refer to the regular maintenance schedule given in “Maintenance Intervals” on page 62 for recommended service intervals after the break-in period.

### **5.3.2. OPERATION**

---

The following items should be checked before operating the machine **each time**:

- Visually inspect the machine, check engine oil, and service the PTO drive-line (if applicable).
- Check that the gas cap is in place (gas drives only).
- Ensure that all guards are in place, and secure.
- Check that drive belts are not frayed or damaged, and that they are properly adjusted and aligned.
- Ensure auger wheels are chocked.
- See that the discharge spout and intake area are free of obstructions.
- Ensure that operators are aware of safety precautions.
- Check that the cable is not frayed or damaged.
- Check that cable clamp(s) are secured.

### NORMAL START-UP

#### NOTICE

Foreign objects can damage the auger. Remove any obstructions from the intake and discharge areas before operating the unit.

#### NOTICE

Engine must be idling before belts are engaged.  
Engaging belts at high engine speed will result in premature belt wear.

1. Disengage the belt engaging lever so the motor pulley is not under load.
2. Start the engine and then engage the belt engaging lever with engine at idle.

**Note:** *The flighting rpm on auger equipped with electric motors is not adjustable.*

#### DANGER



Rotating Flight Hazard: Keep away from auger intake.

3. Increase the engine speed to achieve the desired augering speed.
4. If everything is operating normally, start running grain through the auger.

## RESTARTING WITH A FULL TUBE

### NOTICE

Always engage belts with engine idling. Engaging belts at high engine speed will result in premature belt wear

The tube may be filled with material if the machine is shut down inadvertently or for an emergency. It is recommended that you restart with the following procedure:

1. With the power source locked out, remove as much of the grain as possible from the tube and intake.
2. Start the engine and run it at half speed. Slowly engage the belt until the auger is brought up to speed.
3. Once the auger has been started, increase the engine speed to achieve the desired augering speed.

## 5.3.3. SHUTDOWN

### NORMAL SHUTDOWN

### NOTICE

Prolonged operation of an empty auger will cause unnecessary wear.

1. Near the end of the load, reduce the feed of grain and decrease the auger speed (if possible).
2. Run the auger until the tube is empty.
3. When auger is clear of grain, disengage the belt, and stop engine/motor, or disengage the PTO.
4. Shut down, and lock out power source.

### EMERGENCY STOP

Although it is recommended that the machine be emptied before stopping, in an emergency situation:

1. Stop or shut down the power source immediately.
2. Stop the flow of material (if applicable).
3. Lock out power, and correct the emergency before resuming work.

### WARNING



Lock out all power before attempting repairs / removing obstructions.

### **5.3.4. CLEANOUT**

---

1. Run the unit to clean out the majority of the grain.
2. Shut down and lock out the power source.
3. Clean grain from the auger and hopper, and dump it into a container.

# 6. Maintenance & Storage

**WARNING** Before continuing, ensure you have read and understand the relevant information in the safety section. Safety information is provided to help prevent serious injury, death, or property damage.

## 6.1. GENERAL MAINTENANCE PROCEDURES

---

The Westfield Auger has been designed and manufactured to meet the highest standards, while requiring minimal maintenance. Following a careful service and maintenance program will provide many years of trouble-free service.

### When performing adjustments, service, or repairs:

- Always take safety into consideration and note “Maintenance Safety” on page 10.
- Use extra caution when cleaning and servicing augers because flighting edges can become sharp.
- Follow proper procedures when mounting a tire on a rim. If in doubt, have a qualified tire repair service perform the required maintenance.

### NOTICE

#### Do not modify the equipment.

Unauthorized modification may impair the function or safety of the equipment, could affect the life of the equipment, and will void your warranty.

### 6.1.1. FLUIDS & LUBRICANTS

---

#### ENGINE OIL

Refer to engine operation manual for recommended oil usage.

#### GEAR OIL

Use SAE approved 90W or equivalent gear oil.

#### GREASE

Use SAE multi-purpose high-temperature grease with extreme pressure (EP) performance or SAE multi-purpose lithium based grease.

#### LUBRICANT STORAGE & HANDLING

Always follow manufacturer’s guidelines for the safe and effective storage and handling of lubricants.

Your machine can operate at top efficiency only if clean lubricants are used. Use clean containers to handle all lubricants. Store them in an area protected from dust, moisture, and other contaminants.

## 6.1.2. MAINTENANCE INTERVALS

Refer to Table 6.1 for recommended maintenance tasks and intervals..

**Table 6.1 Maintenance Intervals**

|                                   | Maintenance Procedure | Time Period    |                         |                           |                          |
|-----------------------------------|-----------------------|----------------|-------------------------|---------------------------|--------------------------|
|                                   |                       | Daily (8000)BU | Periodically (40,000)BU | Annually (Before Storage) | Annually (After Storage) |
| Visually Inspect the Unit         | 6.1.3.                | X              |                         |                           |                          |
| Check engine oil level            | 6.1.9.                | X              |                         |                           |                          |
| Service PTO Driveline             | 6.1.13.               | X              |                         |                           |                          |
| Check Air Filter (gas model only) | 6.1.9.                |                | X                       |                           |                          |
| Service Upper Chain Drive         | 6.1.4.                |                | X                       |                           |                          |
| Service Belts                     | 6.1.15.               |                | X                       |                           |                          |
|                                   | 6.1.16.               |                |                         |                           |                          |
| Grease Machine                    | 6.1.5.                |                | X                       |                           |                          |
| Check Gear Box Oil Level          | 6.1.10.               |                | X                       |                           |                          |
| Check Winch                       | 6.1.14.               |                | X                       |                           |                          |
| Clean Machine                     | 6.1.6.                |                |                         | X                         |                          |
| Service Engine (gas model only)   | 6.1.9.                |                |                         |                           | X                        |
| Repack Wheel Bearings             | 6.1.7.                |                |                         |                           | X                        |
| Tighten Wheel Bolts               | 6.1.8.                |                |                         |                           | X                        |
| Change Gear Box Oil               | 6.1.11.               |                |                         |                           | X                        |
| Service Truss Cables              | 6.1.12.               |                |                         |                           | X                        |

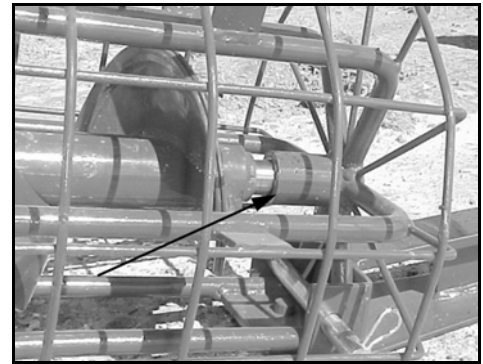
## 6.1.3. VISUAL INSPECTION

Before beginning the visual inspection, chock auger wheels and ensure that all operators are aware of safety precautions.

When inspecting look for possible defects, and the following:

- Ensure all guards are in place, and in good working order.
- Examine the auger for damage or unusual wear.
- Inspect the machine for evidence of oil leaks.
- Examine hydraulic hoses and fittings for leaks and cracks.
- Be sure all safety decals are in place and are legible.
- Check that drive belts are not frayed or damaged. Ensure they are properly adjusted and aligned.

- Check that PTO driveline is connected securely (where applicable).
- Check that the discharge spout and intake area are free of obstructions.
- Ensure that intake housing fasteners are properly secured.
- Examine all flighting for damage or unusual wear.
- Examine tires for gashes, uneven wear, or loss of air pressure.
- Inspect auger shaft bushing for unusual wear or discoloration.
- Inspect all truss cables for tension, and possible failure points.
- Inspect winch cable for fraying, kinks, unwinding, or other possible damage.



**Figure 6.1 Auger Bushing**

### 6.1.4. SERVICING UPPER CHAIN DRIVE

1. Lock out power.
2. Remove cover plate from discharge end of auger.
3. Check chain slack.
  - Chain slack is checked at the midpoint of the longest span. It should be no more than 5/16" (8 mm).



**Figure 6.2 Upper Chain Driver**

#### **NOTICE**

Improper adjustment of chain will result in premature wear.

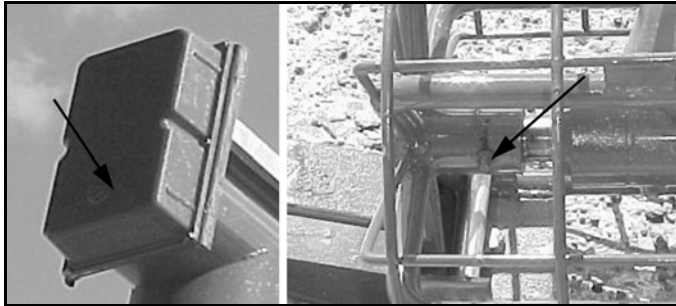
4. Adjust the chain slack.
  - Remove the connecting link from the chain.
  - Remove a link from the chain; if the chain will not fit with one link removed, add a half link to the chain and replace.
5. Grease the chain with appropriate lubricant (Section 6.1.1.)
6. Reattach cover plate.

## 6.1.5. GREASING MACHINE

---

**Important:** *Original equipment bearings used by Westfield are sealed units and will not accept grease.*

1. Lockout all power.
2. Grease points on the machine are shown in Figure 6.3.



**Figure 6.3 Upper Chain Drive Zerk & Intake Zerk**

3. Use grease recommended in Section 6.1.1.
4. Use only a hand-held grease gun.
5. Wipe grease fitting with a clean cloth before greasing to avoid injecting dirt and grit.
6. If a fitting will not take grease, remove and clean thoroughly. Also clean lubricant passageway. Replace fitting if necessary.
7. Replace and repair broken fittings immediately.

## 6.1.6. CLEANING MACHINE

---

1. Lockout all power.
2. Clean out excess grain from auger tube and intake.
3. Make sure nothing is obstructing the auger intake so water can run out.
4. Wash the tube with a water hose or pressure washer until all dirt, mud, debris, or residue is washed from the auger.
5. Provide sufficient time for the water to drain from the auger.

## 6.1.7. REPACKING WHEEL BEARINGS

---

1. Block wheels and ensure unit is stable.
2. Remove the wheel bolts and the wheels.
3. Remove the wheel bearing and pack with grease. Refer to Section 6.1.1. for recommended grease.



## 6.1.8. TIGHTENING WHEEL BOLTS

1. Clean wheel and hub mounting surfaces to ensure there is no rust or debris.
2. Install the wheel and “finger tighten” the wheel bolts. Inspect to make sure the wheel is sitting flush with the hub.
3. Tighten the wheel bolts with a torque wrench to 80 ft-lb ( $\pm 10$  ft-lb) of torque.

**Note:** Tighten the wheel bolts in a diagonal pattern as in Figure 6.4.

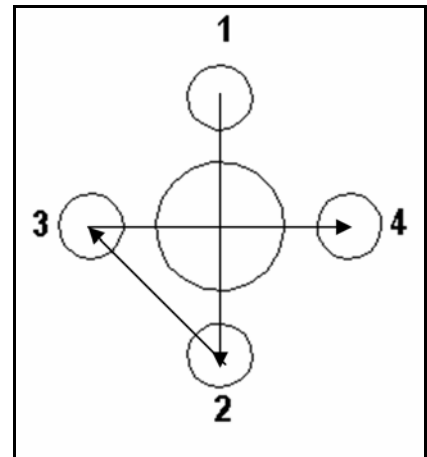


Figure 6.4 Diagonal Pattern

## 6.1.9. SERVICING ENGINE

1. See engine operation manual for service requirements.

## 6.1.10. CHECKING GEAR BOX OIL LEVELS

1. Lock out all power.
2. Remove oil filler plug.
3. Make sure the gearbox is half full (center of cross shaft) and free of foreign objects. Gearbox should be level when checking gears.

## 6.1.11. CHANGING GEARBOX OIL

1. Remove guards and gearbox from auger.
2. Place a pan under the drain plug.
3. Use a wrench and remove the drain plug.
4. Loosen the filler plug so air can enter the gearbox and the oil will drain freely.
5. Allow the oil to drain completely.
6. Replace the drain plug.
7. Add oil until the gearbox is half full (center of cross shaft) and replace filler plug. Gearbox should be level when checking or refilling. Do not overfill.
8. Reinstall gearbox and guards.

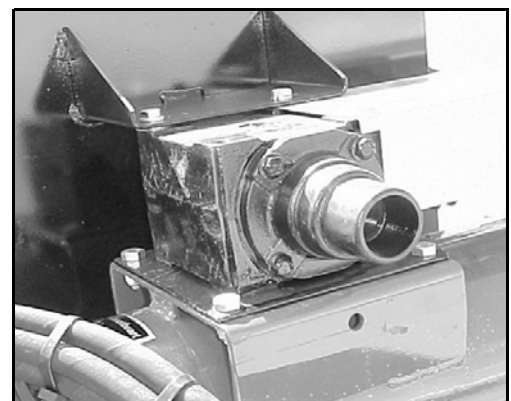



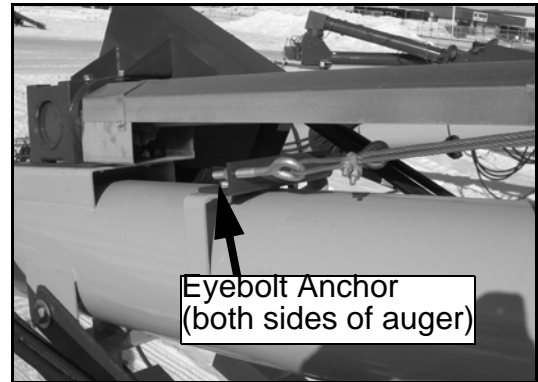
Figure 6.5 Gearbox

## 6.1.12. SERVICING TRUSS CABLES

---

| WARNING   |  |
|---|--|
|  | Before servicing the trussing, ensure auger tube is properly supported by overhead crane or other proper lifting device. |

1. Locate the eyebolt anchors for the cable. Refer to Figure 6.6.
2. Tighten the nut on the eyebolt until there is enough tension in the cable as to keep the tube straight.
3. If the proper cable tension cannot be obtained before the eyebolt runs out of adjustment:
  - Support auger tube.
  - Loosen the eyebolts but do not remove the nut.
  - Loosen the clamps on the cable on both sides.
  - Shorten the cable until there is tension on the cable and tighten the clamps.
  - Return to Step 2.



**Figure 6.6 Cable Adjustment**

## 6.1.13. SERVICING PTO DRIVELINE

---

1. Lock out all power.
2. Check shield and replace if damaged.
3. Use grease recommended in Section 6.1.1.
4. Lubricate both universal joints after every 8 hours of operation. Lubricate the center portion of the driveline (grease fitting is beneath shield) on a yearly basis (where applicable).

## 6.1.14. SERVICING WINCH

---

1. Service winch with auger in fully lowered position and cable slack.
2. Check to make sure cable clamps are secure.
3. Keep a film of grease on gears. Occasionally oil the bushings, drumshaft and ratchet. Take care not to get oil or grease on brake discs.
4. Inspect brake discs, replace if less than 1/16" (2 mm) thick.

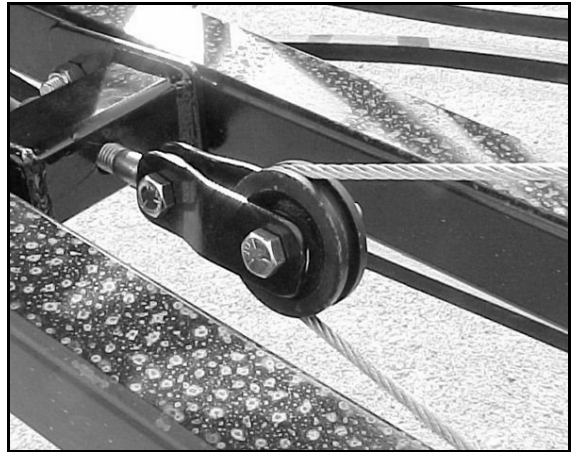


Figure 6.7 Cable Pulley

## 6.1.15. REPLACING BELTS

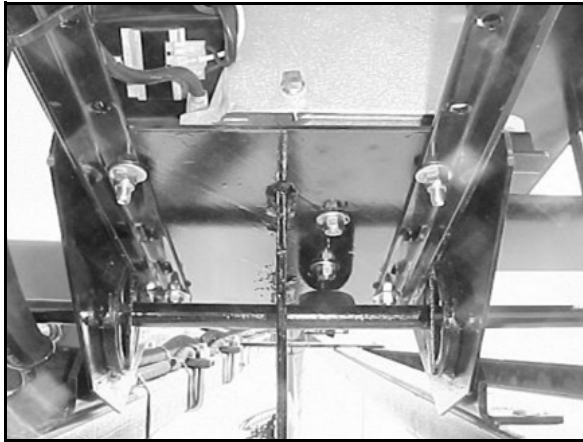
---

1. Lock out all power.
2. Make sure that the belt engaging lever is disengaged.
- ➔ 3. **On motor drive:** Remove pulley shield at motor if necessary (belts may slip past pulley without removing shield). If belts do not come off easily, the engine mounting bolts will have to be loosened and the engine pushed toward the intake end of the auger.
- ➔ 4. **On PTO drive:** The PTO driveline and shield will need to be removed before the belts can be taken off the pulley.
5. The new auger belts can now be put in place. Make sure to route the belt over the idler pulley.
6. Follow the procedure in Section 6.1.16. for the proper belt tension.
7. Re-attach shield and PTO driveline (where applicable).

## 6.1.16. TIGHTENING BELTS

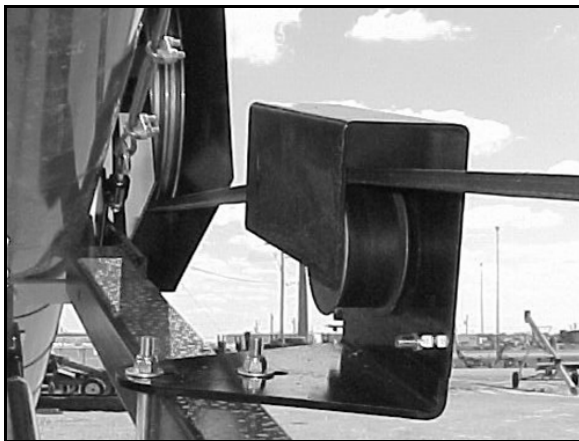
---

1. Lock out all power.
2. Engage the belt engaging lever.
3. Loosen the bolts on the engine mount shown in Figure 6.8.



**Figure 6.8 Engine Mount Bolts**

8. Slide the engine back (towards the spout) until there is adequate tension on the belt. If the alignment of the pulleys needs adjustment, slide the engine left or right until the pulleys line up.
9. Re-tighten the engine mount bolts and torque as shown in the tables in the Appendix. See “Bolt Torque Values” on page 73.
10. Minor tension adjustments can be made by sliding the idler up or down. Idler shown in Figure 6.9.



**Figure 6.9 Belt Idler**

## 6.2. GENERAL STORAGE PROCEDURES

To ensure a long, trouble-free life, the following procedure should be followed when preparing the unit for storage after the season's use:

- Lower auger fully, with slight tension on the cable.
- Lock out all power.
- Check tire pressure and inflate to manufacturer recommended pressure.
- Store the machine on a level surface, free of debris, and in an area away from human activity. Store in a dry place, or use a tightly secured tarp to protect the equipment from the weather.
- Ensure that the unit is in transport position.
- Remove all residual material and clean the machine thoroughly.
- Inspect the unit at stress points for cracks.
- Repair or replace any worn or damaged components to prevent any unnecessary downtime at the start of the next season.
- Touch up paint nicks and scratches to prevent rusting.
- Check hydraulic fittings, hoses, lines, couplers, and valves. Tighten any loose fittings. Replace any hose that is badly cut, nicked, abraded, or is separating from the crimped end of the fitting. Secure the hoses to the machine.
- Inspect and tighten all fasteners; replace fasteners if required.
- Inspect the engine for any abnormal leaks, check the air filter and clean or replace as necessary. Drain the gas from the carburetor and gas tank. Check to see if there is sufficient oil in the crankcase.
- Support intake on blocks to eliminate prolonged contact with the ground.
- Lubricate all grease fittings.
- Cover motor/engine to protect from weather.
- Chock wheels.
- Remove battery (where applicable) and store in a cool, dry place.

### WARNING



To reduce the risk of injury or death to persons using this equipment, follow basic safety precautions.

#### **When handling batteries:**

Exercise caution; batteries contain acid which can eat through clothing, burn skin, and cause blindness.



# 7. Troubleshooting

The following table lists the causes and solutions to some potential problems you may encounter in operating your TFX2 1051 Auger.

**Table 7.1**

| PROBLEM                                   | CAUSED BY   | SOLUTION   |
|---|---|--|
| The auger does not turn.                  | auger is plugged or obstructed                    | identify and remove obstruction  |
|   | drive belt is slipping                            | adjust the tension of the belt   |
|   |   | fully engage the belt release  |
|   | a bearing is seized                               | identify the bearing and replace   |
|   | a chain is broken                                 | identify the chain and repair or replace                                       |
|   | gearbox is seized                                 | fix or replace the gearbox   |
| gearbox coupler bolt is broken or missing | replace the bolt                                  |  |
| Intake flight will not turn.              | center coupler bolt is broken or missing          | replace the bolt   |
| Auger is noisy.                           | obstruction in the auger                          | identify and remove obstruction  |
|   | auger shaft bolts are loose or damaged            | tighten or replace bolts   |
|   | auger shaft is bent                               | repair or replace auger  |
|   | flighting is damaged                              | repair or replace auger  |
|   | worn bearing                                      | repair or replace bearing  |
|   | low gear oil level                                | inspect the gearbox, replace if damaged or add oil if not damaged              |
|   | upper chain drive loose                           | tighten the chain as required  |
| The auger will not raise or lower.        | auger is already at its maximum or minimum height | if at maximum height, lower the auger<br>if at minimum height, raise the auger |
|   | broken cable                                      | replace cable  |
|   | obstruction in the slide                          | clear the obstruction  |
|   | winch is seized                                   | consult your local Westfield dealer  |
|   | the bottom or top of auger is obstructed          | clear the obstruction  |
| Low material augering rate.               | engine speed is too slow                          | increase rpm of the engine   |
|   | inadequate material flow from truck or hopper     | increase flow of material  |
|   | flow into the auger intake is restricted          | clear grating of obstructions  |
|   | material too wet or heavy                         | unloading rates are for dry grain  |
|   | flighting is worn                                 | repair or replace as required  |
|   | belt slipping                                     | identify the belt, adjust or replace as required                               |
| Auger will not hold in elevated position. | malfunctioning or damaged winch mechanism         | consult your local Westfield dealer  |
| Tube is flexing.                          | loose truss cables                                | tighten cables as required   |





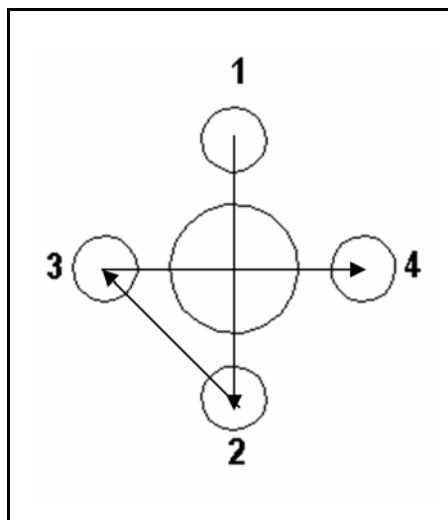
# 8. Appendix

## 8.1. BOLT TORQUE VALUES

The tables shown below give correct torque values for various bolts and capscrews. Tighten all bolts to the torque specified in the chart unless otherwise noted. Check tightness of bolts periodically, using the bolt torque chart as your guide. Replace hardware with the same strength bolt.

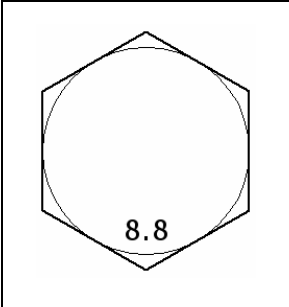
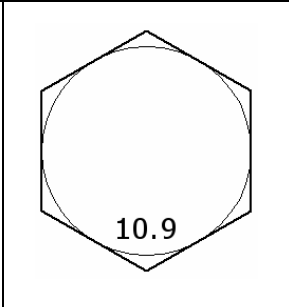
**Table 8.1 Imperial Bolt Torque**

| BOLT DIAMETER | SAE 2 |         | SAE 5 |         | SAE 8 |         |
|---------------|-------|---------|-------|---------|-------|---------|
|               | (Nm)  | (lb-ft) | (Nm)  | (lb-ft) | (Nm)  | (lb-ft) |
| 1/4"          | 8     | 6       | 12    | 9       | 17    | 12      |
| 5/16"         | 13    | 10      | 25    | 19      | 36    | 27      |
| 3/8"          | 27    | 20      | 45    | 33      | 63    | 45      |
| 7/16"         | 41    | 30      | 72    | 53      | 100   | 75      |
| 1/2"          | 61    | 45      | 110   | 80      | 155   | 115     |
| 9/16"         | 95    | 60      | 155   | 115     | 220   | 165     |
| 5/8"          | 128   | 95      | 215   | 160     | 305   | 220     |
| 3/4"          | 225   | 165     | 390   | 290     | 540   | 400     |
| 7/8"          | 230   | 170     | 570   | 420     | 880   | 650     |
| 1"            | 345   | 225     | 850   | 630     | 1320  | 970     |



**Figure 8.1 Pattern for Tightening Wheel Bolts**

**Table 8.2 Metric Bolt Torque**

|                      |  |                |  |                |
|----------------------|---|----------------|--|----------------|
| <b>BOLT DIAMETER</b> | <b>(Nm)</b>   | <b>(lb-ft)</b> | <b>(Nm)</b>  | <b>(lb-ft)</b> |
| M3                   | 0.5   | 0.4            | 1.8  | 1.3            |
| M4                   | 3   | 2.2            | 4.5  | 3.3            |
| M5                   | 6   | 4              | 9  | 7              |
| M6                   | 10  | 7              | 15   | 11             |
| M8                   | 25  | 18             | 35   | 26             |
| M10                  | 50  | 37             | 70   | 52             |
| M12                  | 90  | 66             | 125  | 92             |
| M14                  | 140   | 103            | 200  | 148            |
| M16                  | 225   | 166            | 310  | 229            |
| M20                  | 435   | 321            | 610  | 450            |
| M24                  | 750   | 553            | 1050   | 774            |
| M30                  | 1495  | 1103           | 2100   | 1550           |
| M36                  | 2600  | 1917           | 3675   | 2710           |

Torque figures indicated above are valid for non-greased or non-oiled threads and head unless otherwise specified. Therefore, do not grease or oil bolts or capscrews unless otherwise specified in this manual. When using locking elements, increase torque values by 5%.

## 8.2. TIGHTENING O-RING FITTINGS

1. Inspect o-ring and seat for dirt or obvious defects.
2. On the angle fittings, back the lock nut off until washer bottoms out at top of groove.
3. Hand-tighten fitting until backup washer or washer face (if straight fitting) bottoms on face and o-ring is seated.
4. Position angle fittings by unscrewing no more than one turn.
5. Tighten straight fittings to torque shown.
6. Tighten while holding body of fitting with a wrench.

**Table 8.3 O-Ring Fittings**

| Tube Size OD (in.) | Nut Size Across Flats (in.) | Torque Values <sup>a</sup> (Nm) | Torque Values <sup>a</sup> (Lb-ft) | # of Turns to Tighten (Flats) | Turn (After Finger Tightening) |
|--------------------|-----------------------------|---------------------------------|------------------------------------|-------------------------------|--------------------------------|
| 3/8                | 1/2                         | 8                               | 6                                  | 2                             | 1/3                            |
| 7/16               | 9/16                        | 12                              | 9                                  | 2                             | 1/3                            |
| 1/2                | 5/8                         | 16                              | 12                                 | 2                             | 1/3                            |
| 9/16               | 11/16                       | 24                              | 18                                 | 2                             | 1/3                            |
| 3/4                | 7/8                         | 46                              | 34                                 | 2                             | 1/3                            |
| 7/8                | 1                           | 62                              | 46                                 | 1-1/2                         | 1/4                            |
| 1-1/16             | 1-1/4                       | 102                             | 75                                 | 1                             | 1/6                            |
| 1-3/16             | 1-3/8                       | 122                             | 90                                 | 1                             | 1/6                            |
| 1-5/16             | 1-1/2                       | 142                             | 105                                | 3/4                           | 1/8                            |
| 1-5/8              | 1-7/8                       | 190                             | 140                                | 3/4                           | 1/8                            |
| 7/8                | 2-1/8                       | 217                             | 160                                | 1/2                           | 1/12                           |

a. The torque values shown are based on lubricated connections as in reassemble.

## 8.3. TIGHTENING FLARE TYPE TUBE FITTINGS

1. Check flare and flare seat for defects that might cause leakage.
2. Align tube with fitting before tightening.
3. Lubricate connection and hand tighten swivel until snug.
4. To prevent twisting the tube(s), use two wrenches. Place one wrench on the connector body. With the second wrench, tighten the swivel nut to the torque shown.

**Table 8.4 Flare Type Tube Fittings**

| Tube Size OD (in.) | Nut Size Across Flats (in.) | Torque Values (N-m) <sup>a</sup> | Torque Values (lb-ft) <sup>a</sup> | # of Turns to Tighten (Flats) | Turn (After Finger Tightening) |
|--------------------|-----------------------------|----------------------------------|------------------------------------|-------------------------------|--------------------------------|
| 3/16               | 7/16                        | 8                                | 6                                  | 1                             | 1/6                            |
| 1/4                | 9/16                        | 12                               | 9                                  | 1                             | 1/6                            |
| 5/16               | 5/8                         | 16                               | 12                                 | 1                             | 1/6                            |
| 3/8                | 11/16                       | 24                               | 18                                 | 1                             | 1/6                            |
| 1/2                | 7/8                         | 46                               | 34                                 | 1                             | 1/6                            |
| 5/8                | 1                           | 62                               | 46                                 | 1                             | 1/6                            |
| 3/4                | 1-1/4                       | 102                              | 75                                 | 3/4                           | 1                              |
| 7/8                | 1-3/8                       | 122                              | 90                                 | 3/4                           | 1                              |

a. \* The torque values shown are based on lubricated connections as in reassemble.



# WARRANTY

Westfield Industries Ltd. warrants products of its manufacture against defects in materials or workmanship under normal and reasonable use for a period of one year after date of delivery to the original purchaser.

Our obligation under this warranty is limited to repairing, replacing, or refunding defective part or parts which shall be returned to a distributor or a dealer of our Company, or to our factory, with transportation charges prepaid. This warranty does not obligate Westfield Industries Ltd. to bear the cost of labor in replacing defective parts. Any defects must be reported to the Company before the end of the one year period.

This warranty shall not apply to equipment which has been altered, improperly assembled, improperly maintained, or improperly repaired so as to adversely affect its performance. Westfield Industries Ltd. makes no express warranty of any character with respect to parts not of its manufacture.

The foregoing is in lieu of all other warranties, expressed or implied, including any warranties that extend beyond the description of the product, and the IMPLIED WARRANTY of MERCHANTABILITY is expressly excluded.

WESTFIELD INDUSTRIES LTD.

ROSENORT, MANITOBA

CANADA

ROG 1W0

# **WESTFIELD**

Part of the Ag Growth International Inc. Group

P.O. Box 39

Rosenort, Manitoba, Canada R0G 1W0

Phone: (866) 467-7207 (Canada & USA) or (204) 746-2396

Fax: (866) 768-4852

website: [www.grainaugers.com](http://www.grainaugers.com)

email: [sales@grainaugers.com](mailto:sales@grainaugers.com)

Copyright AGI - Ag Growth International 2014



Printed in Canada