

WESTFIELD

GRAIN AUGERS

TF SERIES

ASSEMBLY & OPERATION MANUAL

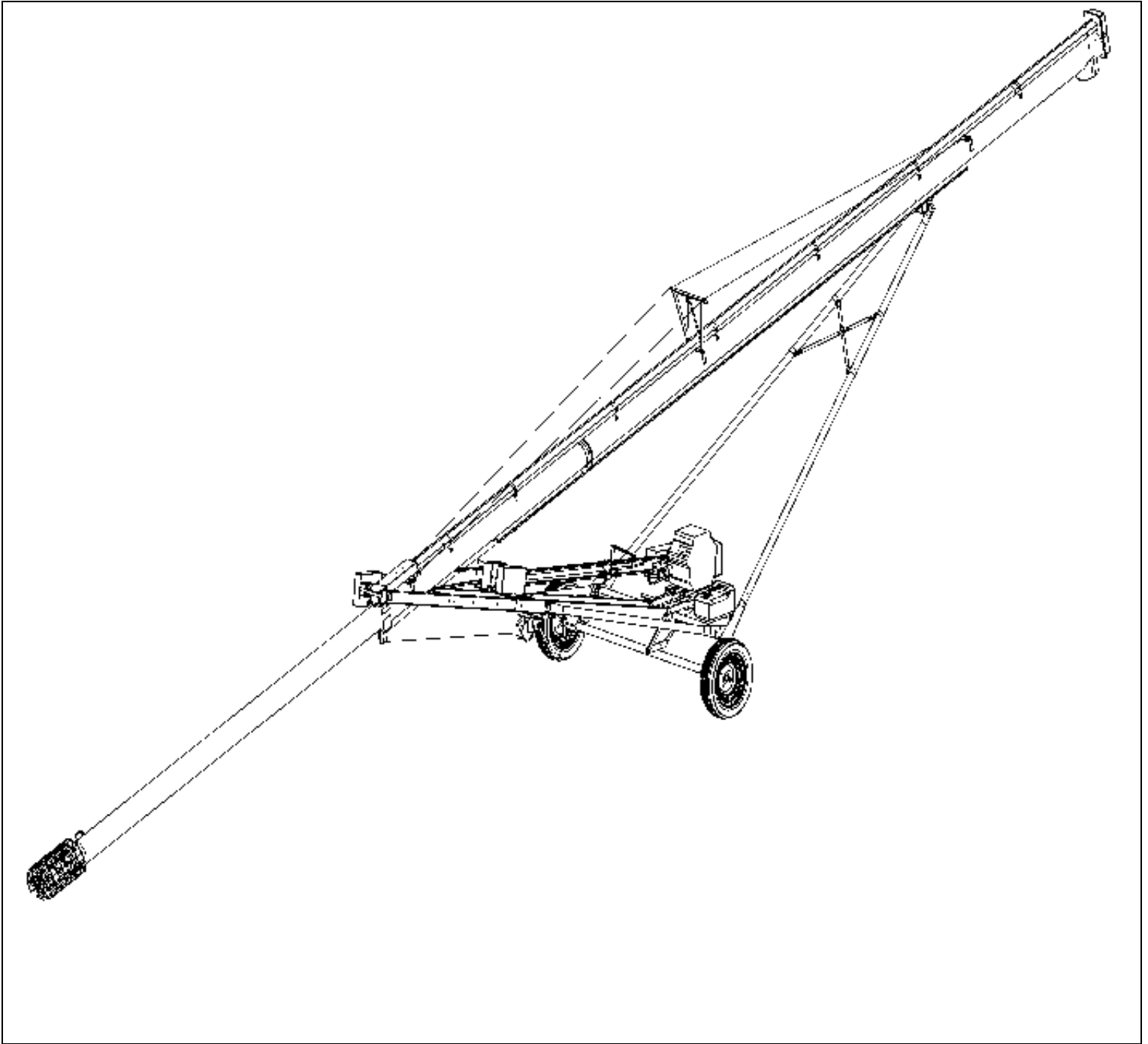

Read this manual before using product. Failure to follow instructions and safety precautions can result in serious injury, death, or property damage. Keep manual for future reference.

Part Number: 30515 01-07

Revised: 28/11/08

TABLE OF CONTENTS

1. Introduction	5
2. Safety First.....	7
2.1. General Safety	10
2.2. Assembly Safety.....	11
2.3. Operational Safety.....	11
2.4. PTO Safety	13
2.5. EMD safety	13
2.6. Battery Safety	13
2.7. Transport and Placement Safety	14
2.8. Maintenance Safety.....	15
2.9. Safety Decal Locations.....	15
2.9.1. Decal Installation	16
2.9.2. Decal Locations	16
3. Assembly	21
3.1. Tubes & Flighting	21
3.2. Track Shoe & Trackstop.....	22
3.3. Intake Hitch	24
3.4. Driveshaft	24
3.5. Gearbox.....	25
3.6. Driveshaft Shield	26
3.7. Truss	27
3.8. Transport Undercarriage	29
3.9. Winch and Liftcable	33
3.10. Winch Cable Routing.....	35
3.11. Winch Handle	37
3.12. Jackshaft	38
3.13. Gas Engine Motor Mount (Optional).....	42
3.14. Belt Tensioner [should this go above 4.12 (standard for all) or is it part of the optional gas motor mount and then below that?] 43	
3.15. EMD Drive (Optional)	51
3.16. PTO Drive (Optional).....	54
3.17. Upper Housing Lubrication.....	58
3.18. Plastic Manual Holder	58
4. Transport & Placement	61
4.1. Transport Procedure	61
4.2. Placement Procedure.....	62

TABLE OF CONTENTS

- 5. Operation 65**
 - 5.1. Pre-Operation Checklist 65
 - 5.2. Auger Drive & Lockout Procedure 65
 - 5.3. Operating Procedure 67
 - 5.3.1. Initial Start-Up 67
 - 5.3.2. Operating with a Full Load 68
 - 5.3.3. Shutdown 68
 - 5.3.4. Lowering & Completion 69

- 6. Maintenance and Storage 71**
 - 6.1. General Maintenance Procedures 71
 - 6.2. General Storage Procedures 74

- 7. Troubleshooting 75**

- 8. Appendix 77**
 - 8.1. Horsepower Requirements 77

- Warranty 79

1. Introduction

Congratulations. As the new owner of a Westfield Grain Auger, you will be working with equipment designed to complement and improve your farming operation. Before using this auger, please read this manual and familiarize yourself with the various features of the machine and the necessary precautions for efficient and safe operation.

In addition, anyone using this auger is required to be familiar with all safety precautions. A sign-off form is supplied on the inside front cover to record your safety reviews.

Thank you.



serial number location?

2. Safety First

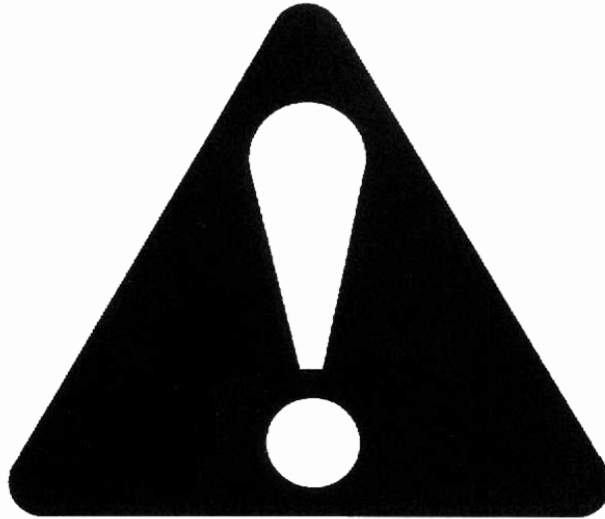

The Safety Alert symbol identifies important safety messages on the product and in the manual. When you see this symbol, be alert to the possibility of personal injury or death. Follow the instructions in the safety messages.

Why is SAFETY important to you?

Three big reasons:

- Accidents disable and kill.
- Accidents cost.
- Accidents can be avoided.

SIGNAL WORDS

Note the use of the signal words **DANGER**, **WARNING**, **CAUTION**, and **NOTICE** with the safety messages. The appropriate signal word for each message has been selected using safety as a guideline.

This Safety Alert symbol means ATTENTION, BE ALERT!, YOUR SAFETY IS INVOLVED.

DANGER

DEFINITION: Indicates an imminently hazardous situation that, if not avoided, will result in serious injury or death. This signal word is limited to the most extreme situations.

WARNING

DEFINITION: Indicates a hazardous situation that, if not avoided, could result in serious injury or death.

CAUTION

DEFINITION: Indicates a hazardous situation that, if not avoided, may result in minor or moderate injury.

NOTICE

DEFINITION: Indicates a potentially hazardous situation that, if not avoided, may result in property damage.

YOU are responsible for the **SAFE** use and maintenance of your product. **YOU** must ensure that you and anyone else who is going to work around the product be familiar with all procedures and related **SAFETY** information contained in this manual.

Remember, **YOU** are the key to safety. Good safety practices not only protect you, but also the people around you. Make these practices a working part of your safety program.

- Product owners must give instructions to employees before allowing them to operate or use the product.
- The most important safety device on this product is a **SAFE** user or operator. It is the user/operator's responsibility to read and understand

ALL safety instructions in the manual and to follow them. All accidents can be avoided.

- A person who has not read and understood all safety instructions is not qualified to operate or use the product. Untrained users/operators expose themselves and bystanders to possible serious injury or death.
- Do not modify the product in any way. Unauthorized modification may impair the function and/or safety, and could affect the life of the product. Any modification to the product voids the warranty.
- Use this product for its intended purposes only.
- Think SAFETY! Work SAFELY!

2.1. GENERAL SAFETY

Important: *The general safety section includes instructions that apply to all safety practices. Any instructions specific to a certain safety practice (e.g. assembly safety), can be found in the appropriate section.*



- Read and understand all safety instructions, safety decals, and manual(s) before assembling or operating equipment.
- Only trained, competent people shall operate or use the product. An untrained operator is not qualified to operate equipment.
- Have a first-aid kit available for use should the need arise, and know how to use it.



- Provide a fire extinguisher for use in case of an accident. Store in a highly visible place.

- Do not allow children, spectators, or bystanders within the work area.

- Wear appropriate protective gear. This list includes, but is not limited to:

- a hard hat
- protective shoes with slip-resistant soles
- protective goggles
- hearing protection



- For powered products: before servicing, adjusting, or repairing, unplug, place all controls in neutral or off position, stop the engine or motor, remove ignition key or lock out power source, and wait for all moving parts to stop.

- Review safety information initially and annually with all personnel who will be using the product.

- Follow good shop practices:

- Keep service area clean and dry.
- Be sure electrical outlets and tools are properly grounded.
- Use adequate light for the job at hand.



2.2. ASSEMBLY SAFETY

- Read through the instructions to get to know the subassemblies and hardware that make up the equipment.
- Do not take chances with safety. The components are large, heavy, and can be hard to handle. Always use the proper tools, stands, jacks, and hoists for the job.
- Always have 2 or more people assembling the equipment. Because of the weight, do not attempt assembly alone.

2.3. OPERATIONAL SAFETY

- Have another trained person nearby who can shut down the auger in case of accident. Always work with a second trained person around augers.
- Do not operate with any of the safety guards removed.
- Keep body, hair, and clothing away from moving parts. Stay away from intake during operation.
- Inspect lift cable before using auger. Replace if frayed or damaged. Make sure it is seated properly in the cable sheaves and that cable clamps are secure.
- Operate auger on level ground free of debris. If ground is uneven, anchor the auger to prevent tipping or upending.
- Augers are not insulated. Keep away from electrical lines. Electrocutation can occur without direct contact.
- Support the discharge end and/or anchor the intake end before operating to prevent upending.
- Do not use auger as a hoist.
- Ensure that auger is empty before raising or lowering.
- Lower auger at completion of operation or when not in use. Auger could drop rapidly in case of cable break or hydraulic failure (where applicable).
- Inspect the drive belt(s) before using auger. Replace if frayed or damaged.
- Lock winch before operating auger.
- Do not grab or touch drive belt(s) during operation for any reason.

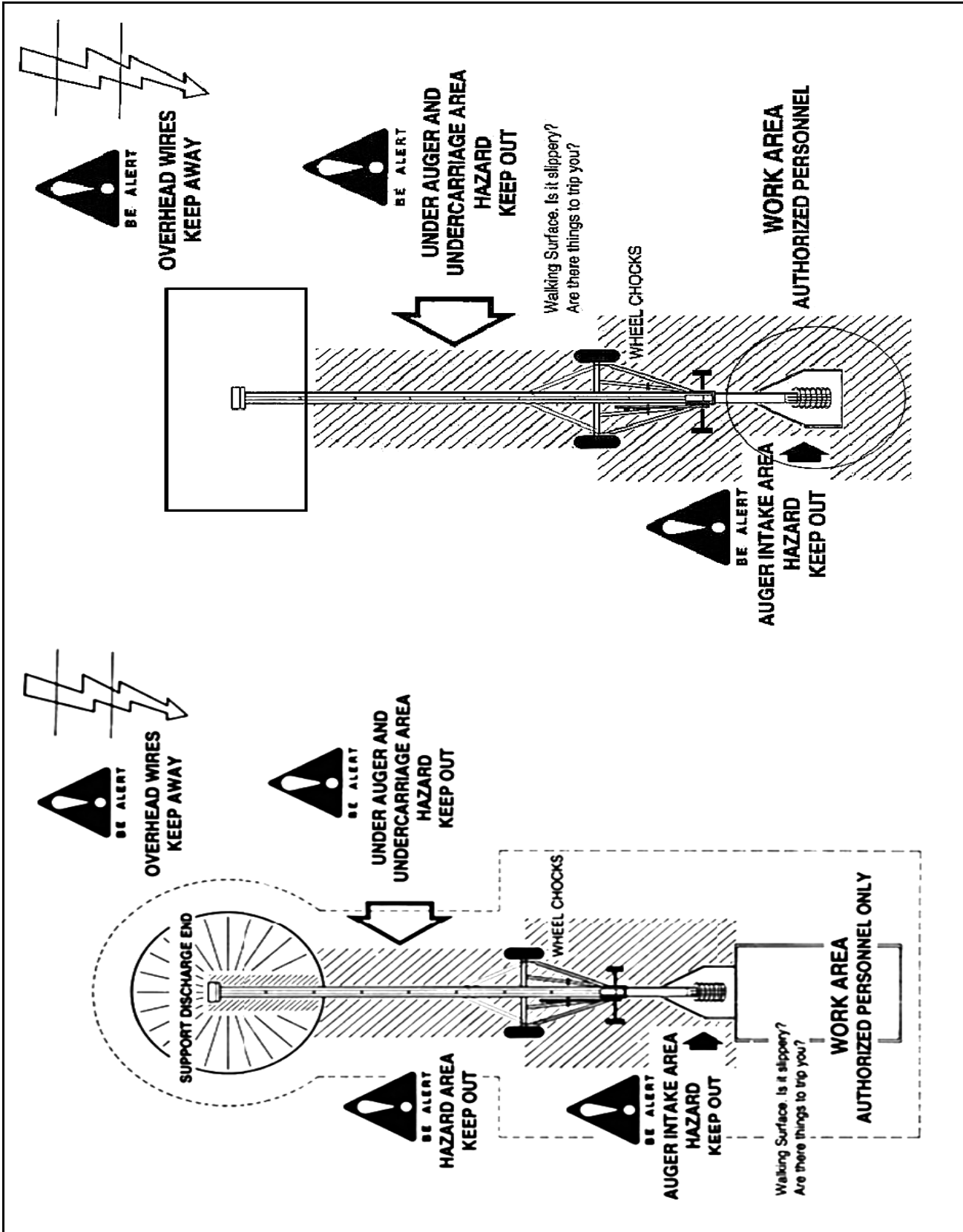

Figure 2.1 Auger Hazard Areas

2.4. PTO SAFETY

- Never use a PTO driveline without a rotating guard in good working order.
- Ensure PTO driveline is securely attached at both ends.
- Before starting tractor, turn power to PTO to the off position (where applicable).

2.5. EMD SAFETY

- Inspect the drive belts before using auger. Replace if frayed or damaged.
- Do not grab or touch drive belts during operation for any reason.
- Remember to ground electric motor before using auger.

2.6. BATTERY SAFETY

- Wear safety glasses when working near batteries.
- Make certain the battery or terminal covers are in place and in good working order.
- Keep all sparks and flames away from batteries; gas given off by electrolyte is explosive.
- Avoid contact with battery electrolyte. Wash off any spilled electrolyte immediately.
- Do not tip batteries more than 45° to avoid electrolyte loss.
- To avoid injury from sparks or short circuits, disconnect battery ground cable before servicing any part of an electrical system.

2.7. TRANSPORT AND PLACEMENT SAFETY

- Transport auger in full down position with slight tension on cable.
- Properly place hitch pin and securely attach safety chain. Use a type of hitch pin that will not allow auger to separate from towing vehicle.
- Always attach an SMV (slow moving vehicle) sign before transporting auger. Equip the auger with the necessary lights for transportation where required by law. Always use hazard warning flashers on the tractor/towing vehicle when transporting unless prohibited by law.
- Always travel at a safe speed, never exceeding 15 mph (24 km/hr). Reduce speed on rough surfaces and be cautious when turning corners or meeting traffic.
- Before raising/lowering/moving the auger, make sure the area around the auger is clear of obstructions and/or untrained personnel. Never allow anyone to stand on or beneath auger while transporting or placing auger.
- Do not transport auger on slopes greater than 20°.
- Wheels must be free to move when raising or lowering auger.
- Never attempt to move auger manually. To do so will result in serious injury.
- Before moving auger, check and double check for overhead obstructions and/or electrical wires. Electrocutation can occur without direct contact.
- Disconnect PTO driveline from tractor before moving auger or tractor and secure in transport saddle (where applicable).
- If the track shoe becomes stuck when lowering the auger, continuing to turn the winch handle counter-clockwise will disengage the brake mechanism

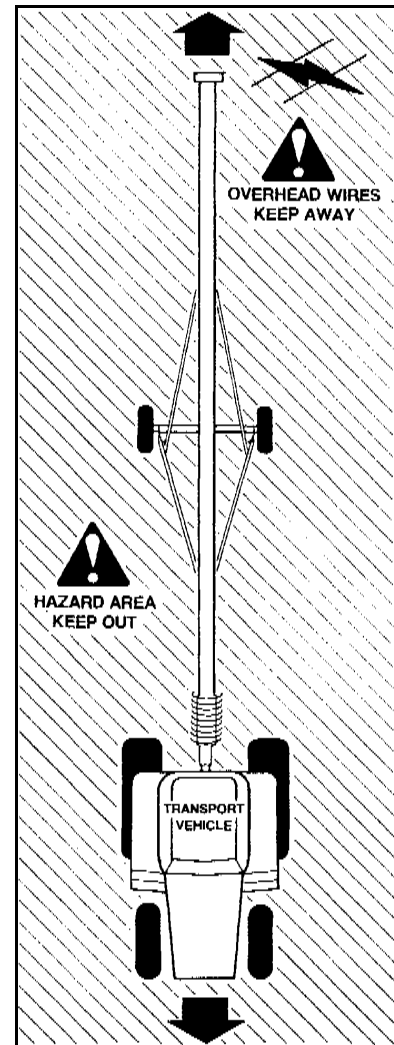

and create an unsafe condition. Too much slack in the cable may also cause the auger to drop suddenly.

- The winch must make a clicking sound when raising auger. If clicking sound stops, retain grip on handle, lower auger fully, and repair winch.
- After lowering auger, turn handle clockwise two clicks to lock winch brake.
- Always keep a minimum of 3 cable wraps on the winch drum.
- The winch is designed for manual operation only.

2.8. MAINTENANCE SAFETY

- Shut down and lock out all power before attempting maintenance of any kind. If applicable, disconnect PTO driveline from tractor or hydraulic hoses on units with hydraulic drive hoppers.
- After maintenance is complete, replace and secure all safety guards and safety devices, and if applicable, service doors and cleanout covers.
- Support auger tube before attempting maintenance on the undercarriage assembly or when removing gearbox. Auger should be in full down position for maintenance.
- Use only genuine Westfield replacement parts or equivalent. Replacement parts such as intake guards, pulley guards, PTO driveline shields, winches, and lift cables must meet ASAE standards or serious injury may result. Use of unauthorized parts will void warranty. If in doubt, contact Westfield or your Westfield dealer. Do not modify any auger components.

2.9. SAFETY DECAL LOCATIONS

- Keep safety decals clean and legible at all times.
- Replace safety decals that are missing or have become illegible.
- Replaced parts must display the same decal(s) as the original part.
- Safety decals are available from your distributor, dealer, or factory.

2.9.1. DECAL INSTALLATION

1. Installation area must be clean and dry, with a temperature above 10°C (50°F).
2. Decide on the exact position before you remove the backing paper.
3. Align the decal over the specified area and carefully press the small portion with the exposed sticky backing in place.
4. Slowly peel back the remaining paper and carefully smooth the remaining portion of the decal in place.
5. Small air pockets can be pierced with a pin and smoothed out using the piece of sign backing paper.

2.9.2. DECAL LOCATIONS

The types of safety decals and locations on the equipment are shown below. Good safety requires that you familiarize yourself with the various safety decals, the type of warning, and the area or particular function related to that area that requires your **SAFETY AWARENESS**.

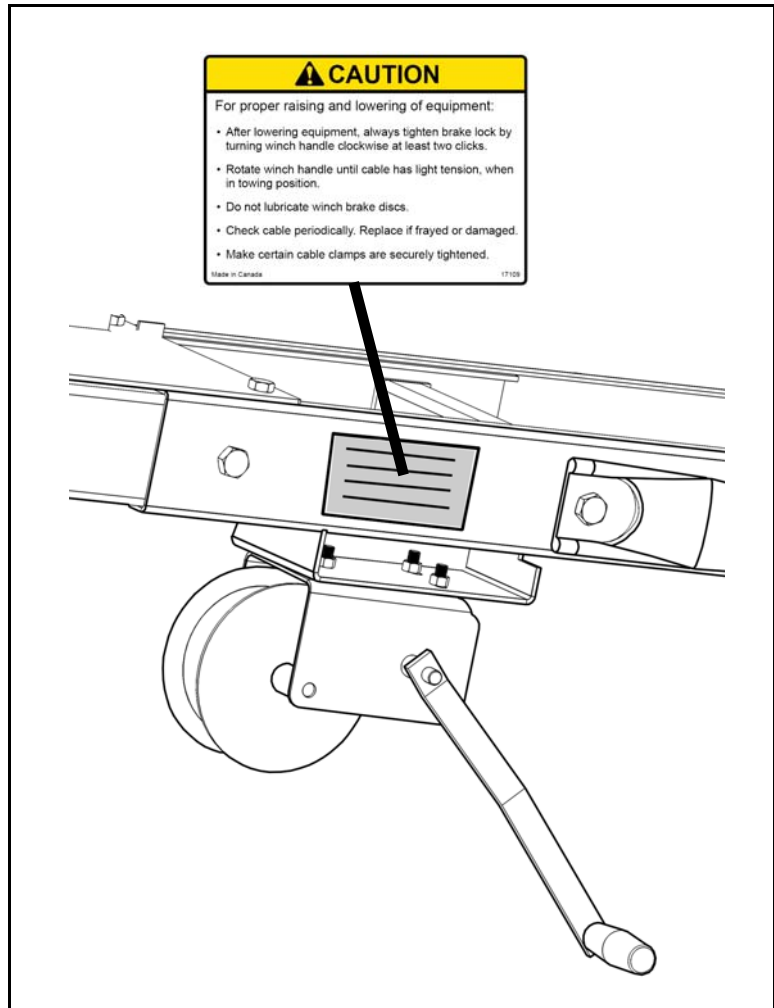

Figure 2.2 Winch Safety Decal

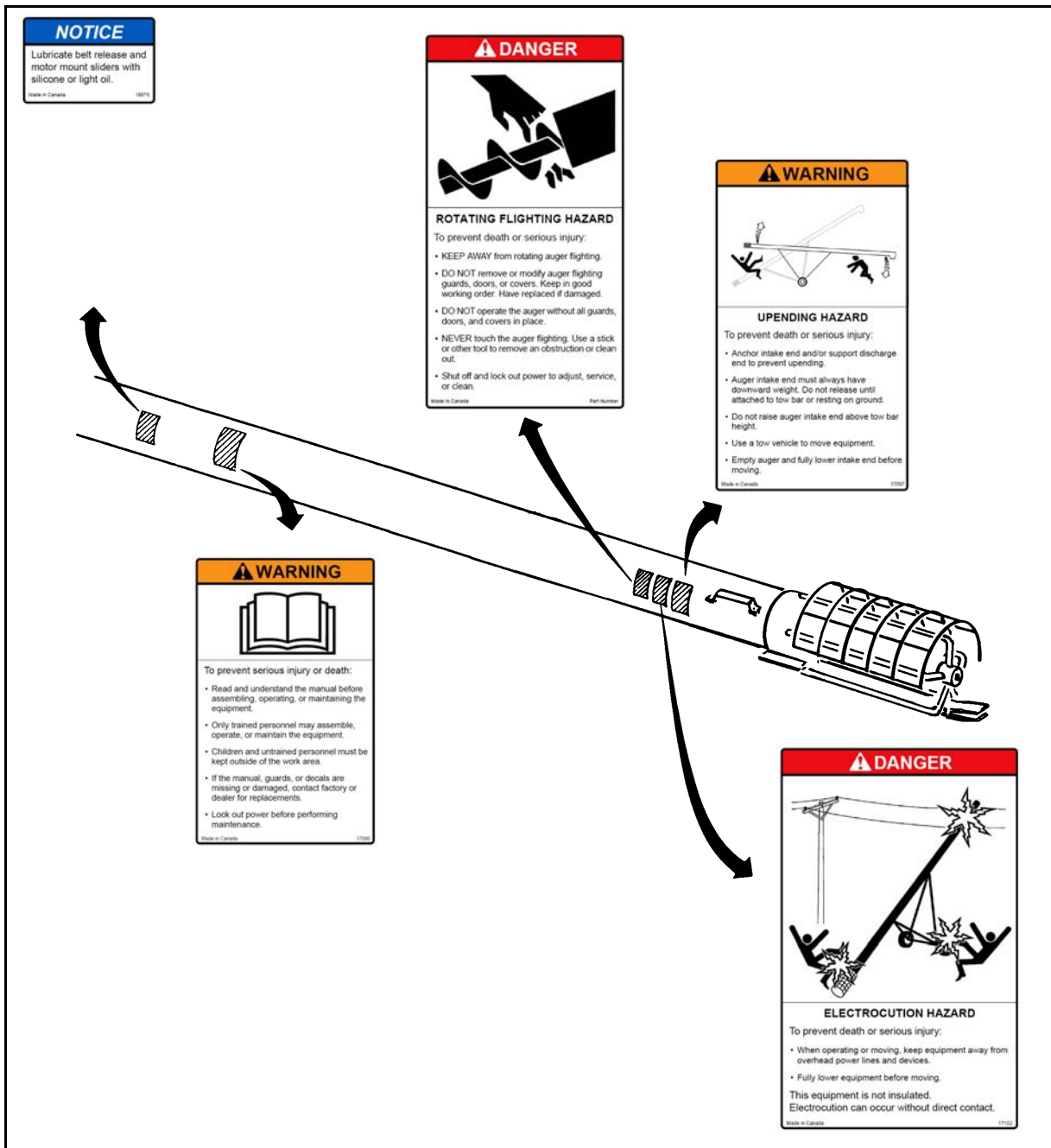

Figure 2.3 Auger Intake Tube Safety Decals

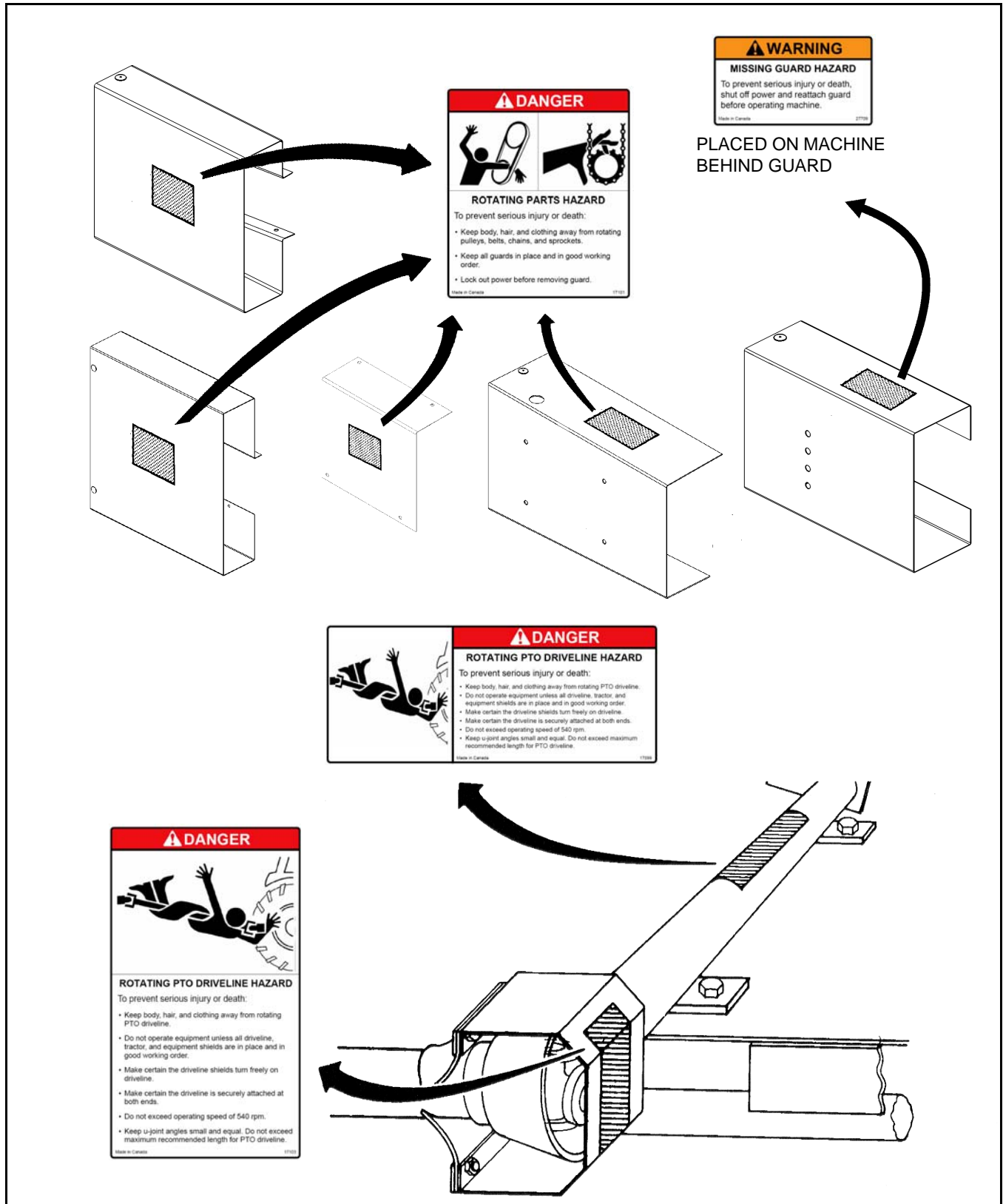

Figure 2.4 V-Belt Guard and PTO Shield Safety Decals

3. Assembly

Before beginning assembly, please read the following instructions carefully and familiarize yourself with all the sub-assemblies and hardware making up the auger. Have all parts on hand and arrange them for easy access. Carry out assembly in a large open area with a level surface.

Important: *Always have 2 or more people assembling the equipment. Because of the weight, do not attempt assembly alone.*

➔ Augers are available in various combinations. In most cases, the following instructions will apply to all augers. Where the assembly information varies, additional instructions will be included, and will be indicated with an arrow.

3.1. TUBES & FLIGHTING

1. Correctly position tube sections. Align tube sections on a flat surface or on a series of benches.

Is there a picture to show this? If not, we can describe the layout. Do all sizes have 2 tubes? Does it matter how they are oriented when laid out?

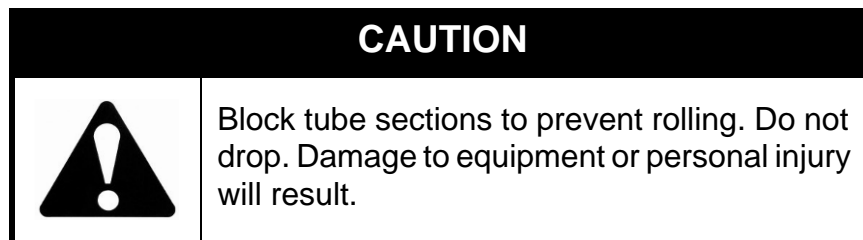

2. Screw or slide lower flight shaft onto upper flight shaft until flight ends butt together and flighting spiral matches up. Secure with hardware listed in table below. Repeat, if necessary, for any remaining flight shafts.

Note: *When assembling more than 2 sections, start from spout end and work towards hopper.*

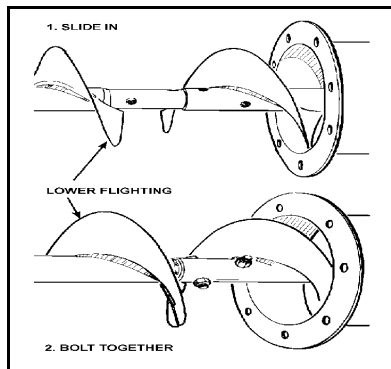

Figure 3.1 Flighting Joint Bolting

- Slide tube sections together and secure. Make sure to align upper and lower track ends and then tighten bolts. Secure with hardware listed in table below.

Details for fastenings:				
Auger	For Flighting	Amt.	For Tubes	Amt.
8"	<ul style="list-style-type: none"> 7/16" x 2-1/4" GR 8 bolts and locknuts 	2	<ul style="list-style-type: none"> 7/16" x 1" bolts and locknuts 	?
10"	<ul style="list-style-type: none"> 1/2" x 2-3/4" GR 8 bolts and locknuts 	2	<ul style="list-style-type: none"> 7/16" x 1" bolts and locknuts 	?

Important: *Track ends must align to allow track shoe to smoothly slide over track joint. Misalignment may cause jamming.*

3.2. TRACK SHOE & TRACKSTOP

- ➔ The 51' auger has a 2-piece lift track. Make sure the upper and lower tube track sections butt together to form a smooth joint for the roller track shoe to roll across. Adjust if necessary (Figure 3.2).

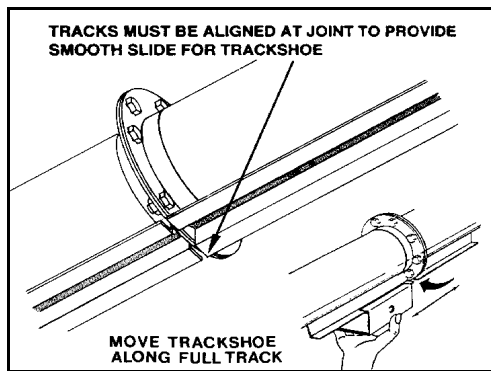

Figure 3.2 51' Lift Track Only

- All augers: slide roller trackshoe onto track. Attach the upper angle-iron trackstop with 7/16" x 1" bolts, heavy flat washers, and locknuts (Figure 3.3).

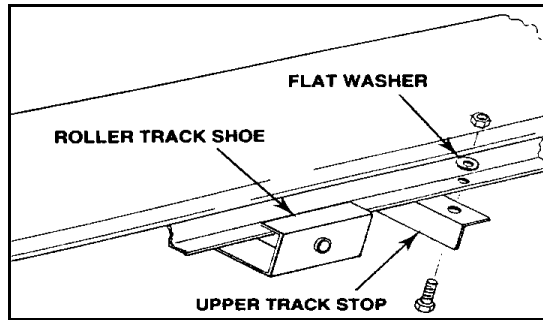

Figure 3.3

- Attach the lower angle-iron trackstop with 7/16" x 1" bolts and locknuts. Tighten securely.

Auger	Upper Track Stop	Lower Track Stop
831	<ul style="list-style-type: none"> only set of holes at top of track 	<ul style="list-style-type: none"> 2nd set of holes from bottom of track
836	<ul style="list-style-type: none"> only set of holes at top of track 	<ul style="list-style-type: none"> 1st set of holes from bottom of track
841	<ul style="list-style-type: none"> 1st set of holes from top of track 	<ul style="list-style-type: none"> 2nd set of holes from bottom of track
846	<ul style="list-style-type: none"> 2nd set of holes from top of track 	<ul style="list-style-type: none"> 1st set of holes from bottom of track
851	<ul style="list-style-type: none"> 3rd set of holes from top of track 	<ul style="list-style-type: none"> only set of holes on short piece of track on lower tube
1031	<ul style="list-style-type: none"> only set of holes at top of track 	<ul style="list-style-type: none"> 2nd set of holes from bottom of track
1036	<ul style="list-style-type: none"> only set of holes at top of track 	<ul style="list-style-type: none"> 1st set of holes from bottom of track
1041	<ul style="list-style-type: none"> 1st set of holes from top of track 	<ul style="list-style-type: none"> 2nd set of holes from bottom of track

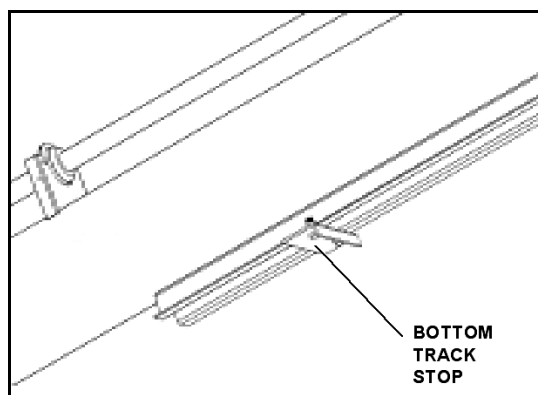



Figure 3.4

CAUTION	
	<p>Failure to locate trackstops in the proper holes can result in damage to auger and/or personal injury.</p>

3.3. INTAKE HITCH

1. Clean dirt and paint from lower flight stub and intake bushing.
2. Attach intake hitch to lower auger tube and tighten securely.
3. Maintain 1/2" clearance between bushing and end of flight. [some say 1/4" - 1/2" min. clearance. Ok to say 1/2" minimum since it's constant for all?]
4. Attach clevis to intake hitch with clevis pin and gripclip.

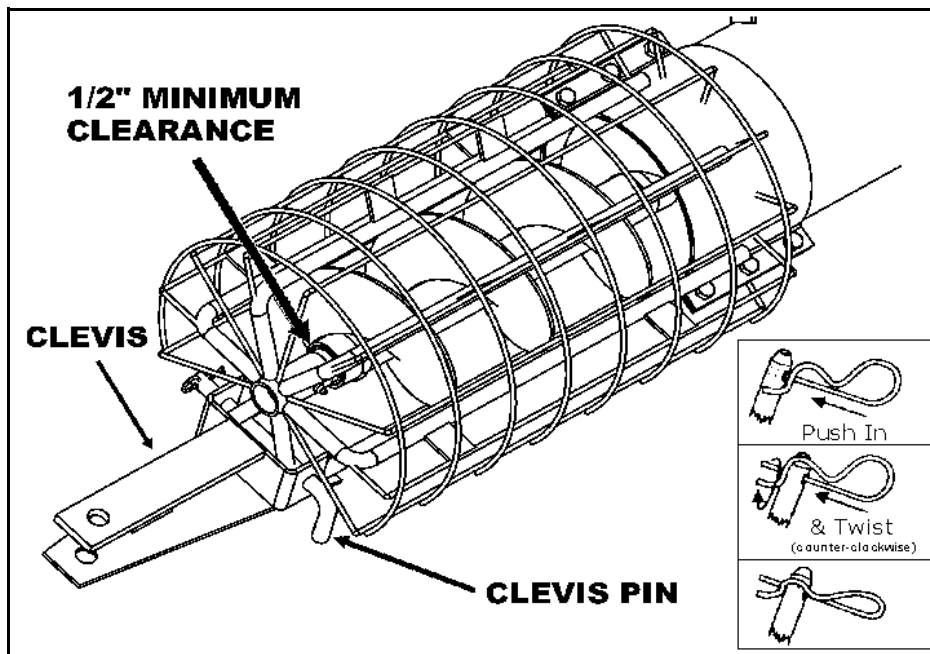

Figure 3.5 Hitch

Part	Size	Amount
Intake Hitch	• 7/16" x 1" bolt and locknut	6
Clevis Pin	• 5/8"	1

3.4. DRIVESHAFT

Most sections of the driveshaft are factory installed.

1. Check table below for correct sequence for your auger.

Table 3.1

AUGER LENGTH	LOWER DRIVESHAFT	
	LENGTH	DIAMETER
8" / 10" x 31'	N/A	N/A
8" / 10" x 36'	2' - 10"	1-1/4"
8" / 10" x 41'	3' - 11-1/2"	1-1/4"
8" x 46'	6' - 11-1/4"	1-1/4"
8" x 51'	10' - 5-3/4"	1-1/4"

2. Clean paint and dirt from driveshaft end and shaft connectors.
3. After installing woodruff key, slide connector halfway onto the last pre-installed driveshaft segment.
4. Slip lower driveshaft segments through bearings on lower tube section, install a Woodruff key, and slide into shaft connector.
5. Tighten all set screws on shaft connectors.
6. Place a few drops of oil at each driveshaft bearing for break-in. These bearings will not require further lubrication because they are self-lubricating.

3.5. GEARBOX

See Figure 3.6.

The gearbox is supplied from the factory mounted to the gearbox plate with chain coupler in place. The PTO drive mount is mounted on the left side of the auger (facing the discharge end of the auger).

If the PTO drive mount must be accessible from the right side of the auger (facing the discharge end of the auger), the gearbox will have to be flipped and mounted opposite. The jackshaft assembly and all pulleys, belts, and guards will also have to be mounted opposite. See Section 3.16. for details.

- **31' auger (all diameters):** Mount gearbox on the gearbox mounting bracket closest to the discharge end of the auger.
- **36' auger:** Mount gearbox to the bracket closest to the intake end.
- [what about other auger sizes?]

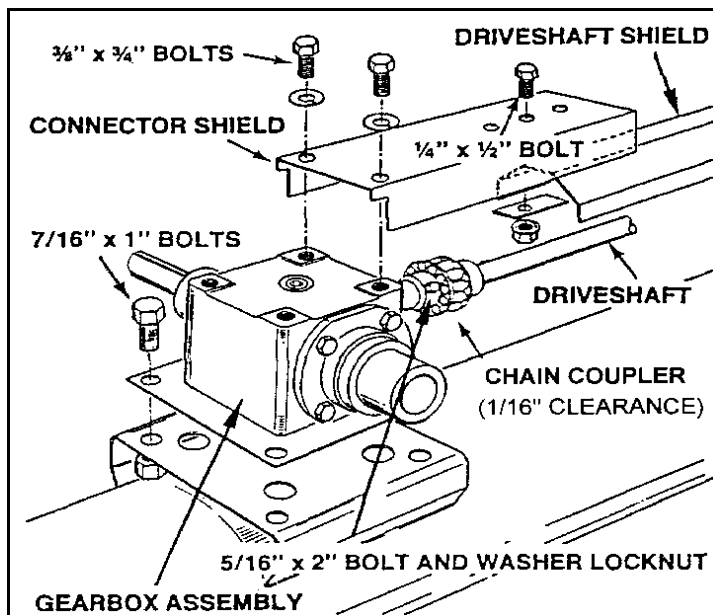

Figure 3.6

To install:

1. Remove chain and secure half the coupler to the driveshaft with a Woodruff key.
2. Place gearbox assembly onto the mounting bracket welded to tube, then reinstall chain, leaving 1/16" clearance between chain coupler sprockets. Secure with four 7/16" x 1" bolts and locknuts.

NOTICE

Maintain a minimum of 1/16" clearance between chain coupler sprockets. Failure to do so can result in damage to gearbox or wood bearings.

Note: Gearbox is sent from the factory half full of EP90 lube oil. Make sure gearbox is half full before operating auger. Add EP90 lube oil if necessary. Failure to do so will void warranty. Do not overfill. It is easier to add oil to gearbox when in flat position. The gearbox requires 224 ml or 8 fl oz.

3.6. DRIVESHAFT SHIELD

Shields are installed working from the gearbox assembly up to the discharge end.

To install:

1. Refer to Table 3.2 for the proper sequence for your particular auger.

2. Attach the connector shield to gearbox (Figure 3.6) with two 3/8" x 3/4" bolts and lockwashers. Attach the first driveshaft shield to the connector shield with one 1/4" x 1/2" bolt, a washer-locknut, and a punched flat iron plate.
3. To install the remainder of the driveshaft shields, work from the bottom up, overlapping at bearing bracket (Figure 3.7).
4. Fasten with shield strap and self-tapping screws. Do not tighten until all shielding is in place.

Table 3.2 TF Driveshaft Shielding Sequence Starting From Gearbox

	STEP 1		STEP 2		STEP 3	
	QTY	LTH	QTY	LTH	QTY	LTH
31'	4	60"	---	---	---	---
36'	1	42"	4	60"	---	---
41'	1	42"	4	60"	1	48"
46'	2	42"	4	60"	1	48"
51'	6	60"	1	48"	---	---

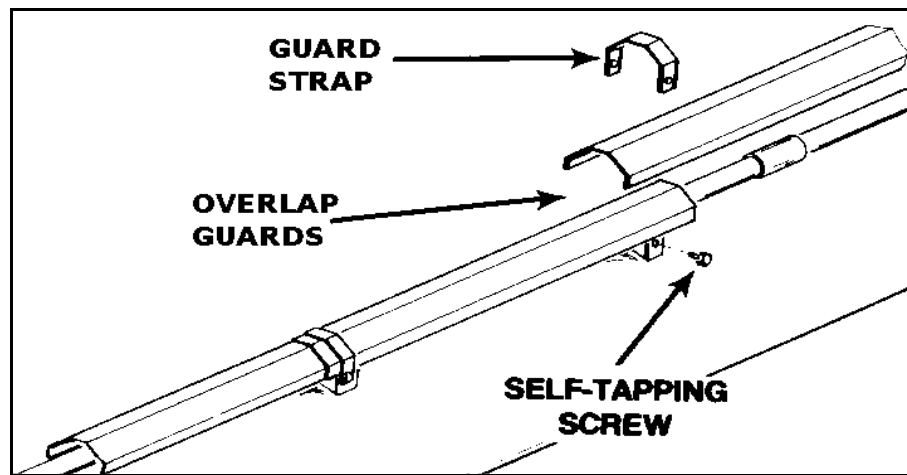

Figure 3.7 Driveshaft Shielding Installation

3.7. TRUSS

- ➔ **46' and 51' Augers Only** (Figure 3.8):
1. Fasten lower truss anchor to bracket.
 - use 7/16" x 1" bolts and locknuts.
 2. Fasten upper truss anchor to upper arm bracket on upper tube using 7/16" x 1" bolts and locknuts.
 3. Mount center truss support bracket with two 7/16" x 1" bolts and locknuts.

4. Attach eyebolt to one end of truss cable with a Pull cable clamp. Insert eyebolt into lower truss anchor and thread on nut a short way.
 - use a 5/16" cable clamp
5. Pull truss cable over truss support brackets, through upper truss anchor, and back over center truss support to lower truss anchor, holding it loosely in place with 2 cable clamps at center truss support.

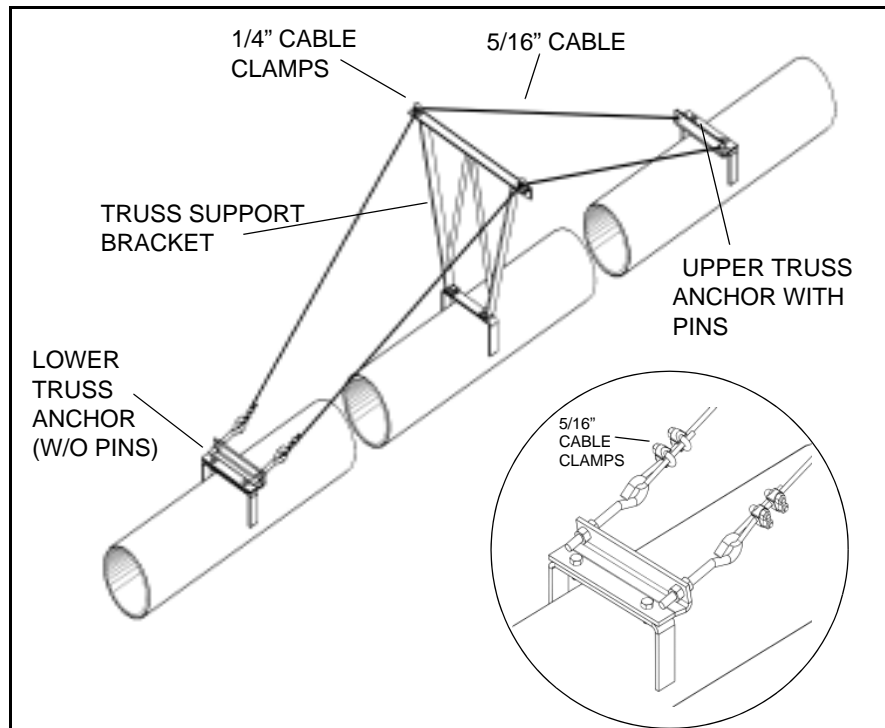

Figure 3.8 Truss Assembly

6. The upper end of augers equipped with truss cables should have an upward bow before being placed on the transport undercarriage (auger tube will straighten when fully assembled). Place supports under the discharge end until upward bow is correct.
 - an upward bow of about 2" for the 46' and 3" on the 51' is reached. **[and what about the bow for the other sizes?]**
7. Place other eyebolt onto lower truss anchor and thread on nut a short way.
8. Insert other end of truss cable through this eyebolt. Pull out all slack and secure with a cable clamp.
9. Tighten eyebolts to take remaining slack out of truss cable and to maintain the appropriate upward bow. After tension is adjusted, tighten cable clamps on truss support brackets and upper truss anchor. Check for proper side alignment.

Important: *Once auger is fully assembled, adjust truss cables on all units (because of initial stretching). Cables may also require adjustment for side alignment.*

3.8. TRANSPORT UNDERCARRIAGE

1. Attach upright brackets to axle using six $7/16$ " x 1" bolts and locknuts, hand-tightened only (Figure 3.9).

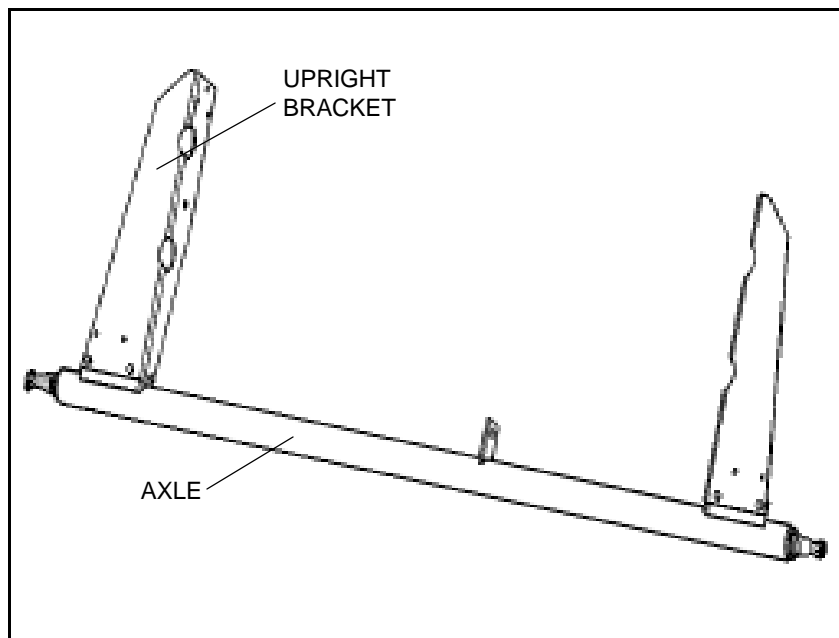

Figure 3.9 Axle Assembly

2. Attach lower frame channel to gearbox channel using one $5/8$ x $1-1/2$ " bolt and locknut in upper hole, and one $5/8$ x 2" bolt and locknut in lower hole. Assemble frame channels according to size of auger (Figure 3.10, 3.11).
 - Tighten upper bolts only. Leave lower bolts loose for now.
 - There are 2 of these assemblies, one for each side of frame. The 31' & 36' frames require one extra $5/8$ " x $1-1/2$ " bolt and locknut.
3. Locate each assembled frame channel onto each side of the gearbox (bends facing in). Let other end of frame channels rest on ground.
4. Install upper frame crossbrace on frame and attach with four $7/16$ " x 1" bolts and locknuts.
5. Assemble frame end piece onto the end of the frame channel at gearbox with four $7/16$ x 1" bolts and locknuts; hand-tighten only.
6. Install lower reach arms (one each side) and lower frame (winch) crossbrace (the one with holes) on frame (Figure 3.10). Tighten loose bolts from step 2. Let other end of reach arms rest on ground.
7. Attach long crossmember to bottom of frame channels and reach arms with twelve $7/16$ x 1" bolts and locknuts.
 - Ensure nuts face inside of frame.

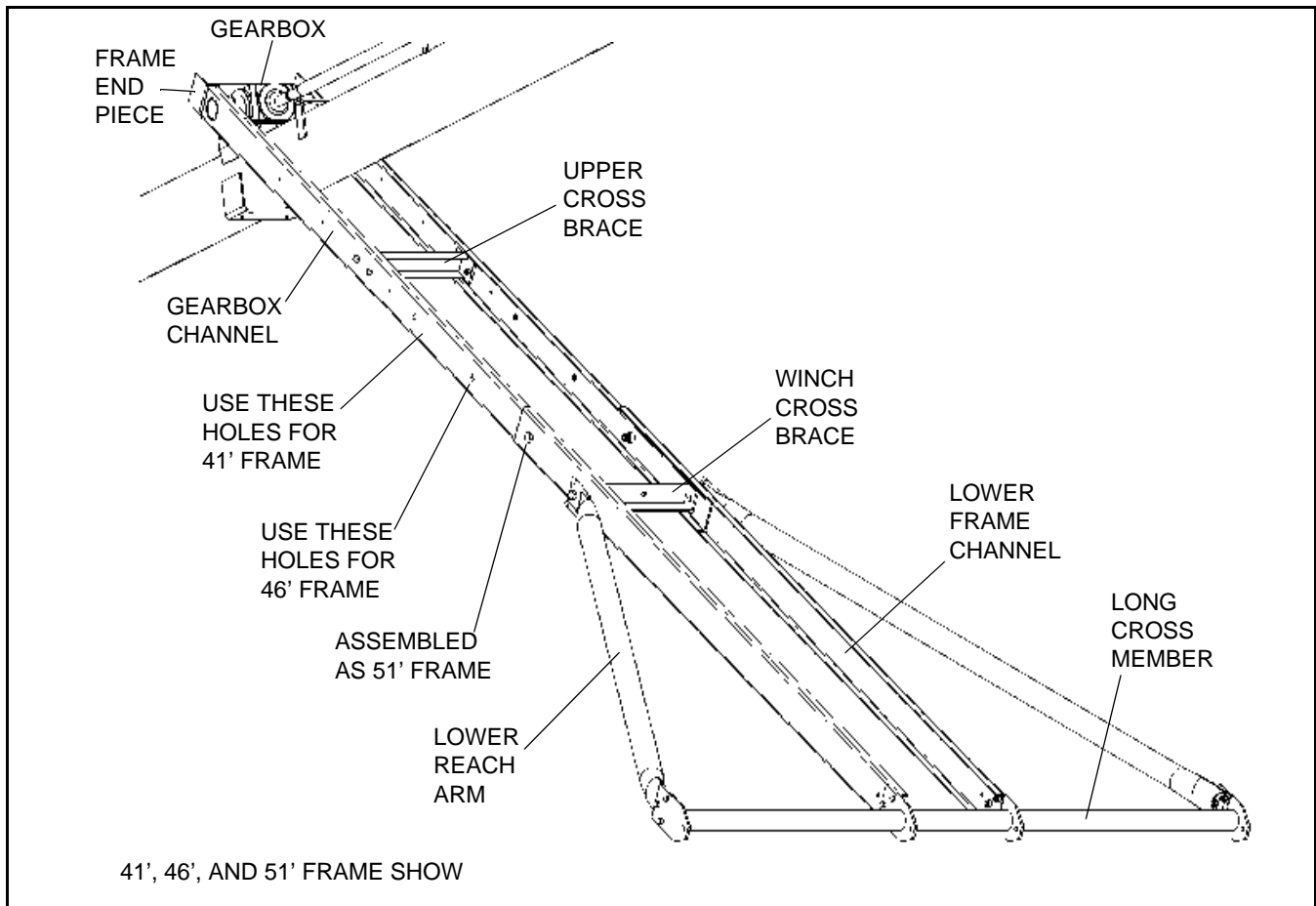

Figure 3.10 Lower Frame Assembly

8. Tighten all bolts and nuts on frame.
9. Wheel hub assembly:
 - a. Remove any dirt or paint from spindle and hub.
 - b. Thoroughly pack wheel bearings and cups with a good grade of bearing grease.
 - c. Place large bearing into hub and carefully tap in seal.
 - d. Slip hub onto spindle and insert small bearing.
 - e. Tighten slotted spindle nut until hub drags slightly. Back off nut about 1/4 turn until hub turns freely.
 - f. Install cotter pin and dust cap.

Note: *If self-propelled wheel kit is used, install ring gear on tire rim before installing tire onto auger.*

10. Install tires and tubes on wheels provided. Inflate to 18–24 psi (124–165 kPa). Wheels may be mounted at this time using four 1/2" x 1-1/4" wheel bolts.

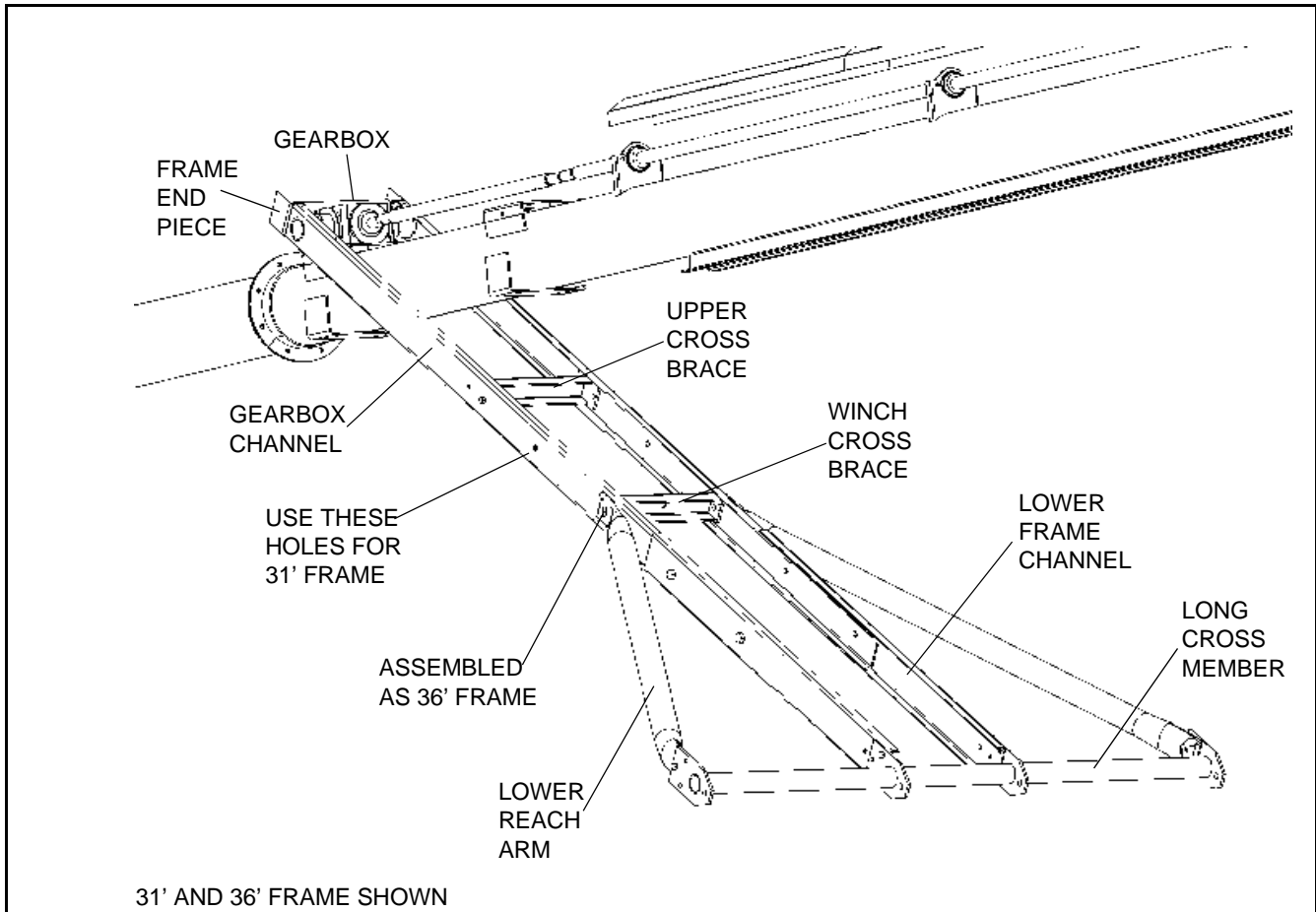
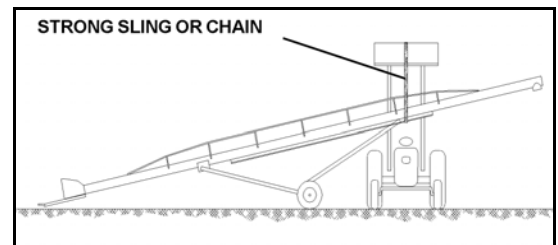

Figure 3.11 Lower Frame Assembly

11. Position the main axle underneath the tube assembly and attach main axle to lower frame with two 5/8" x 1-1/2" bolts and locknuts (Figure 3.12).
12. Attach upper arms to main axle with six 7/16" x 1" bolts and locknuts.
13. Raise the upper end of auger with a block and tackle or a front-end loader and a strong sling or chain. Height should be sufficient to clear undercarriage. If the undercarriage will not clear, remove tires and reinstall after assembly..



NOTICE

Do not remove tube support until assembly has been completed.

14. Attach both upper lift arms to roller trackshoe with one 5/8" x 6-1/2" bolt and locknut. **Do not over-tighten.** Tighten snug only; this bolt acts as a pivot point (Figure 3.13).
- ➔ 15. For auger models **841, 846, 851, and 1041** only, install crossbraces on upper frame with four 3" tube clamps and four 7/16 x 1-1/4" bolts and locknuts. Use a 1/2 x 1-1/4" bolts and locknut for the center (where crossmembers intersect)[singular or plural bolts and locknuts?](Figure 3.12).[would it be better to refer to models by size rather than number?]
16. Some adjustments will be required to make all the braces fit correctly. To start, position the bottom edge of the bottom tube clamp (on each tube) the following distance from the bottom edge of the upright tube:

841/1041:	65"
846:	76"
851:	89"

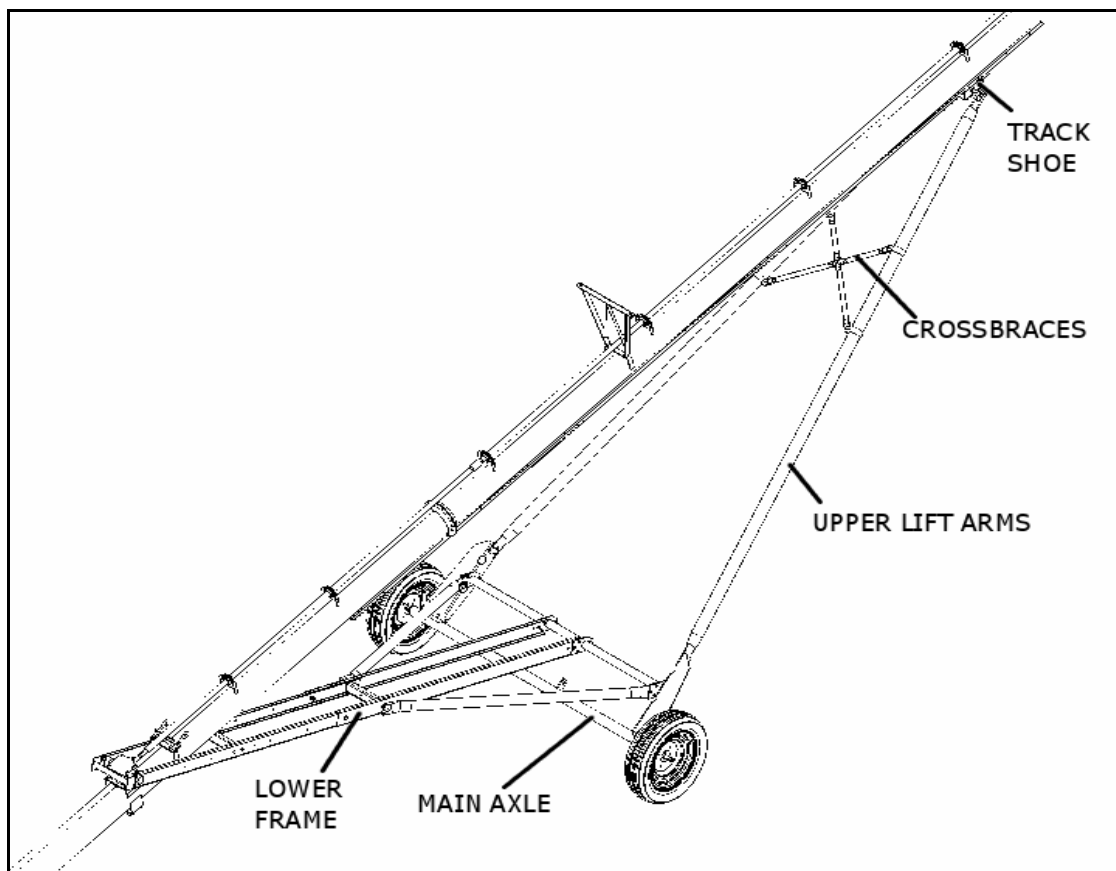

Figure 3.12 Frame Assembly

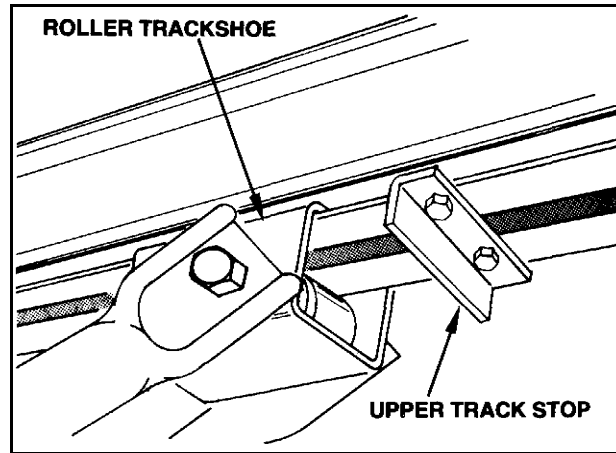
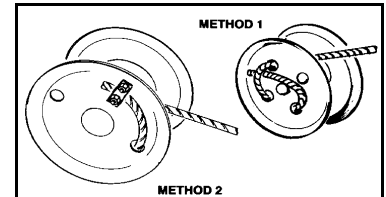

Figure 3.13 Track Shoe Bolt Installation

3.9. WINCH AND LIFTCABLE

1. Attach cable to winch using one of the 2 methods shown, depending on supplied winch.
 - If method 2 is used, the nut must be on the outside of the drum to prevent damage to the cable. Leave about one inch of cable extending past the clamp. Cable must leave winch from bottom side.



2. The winch must have a minimum of 3 wraps of cable on drum when auger is in transport position.
3. Attach winch to mount with three 3/8" x 1" bolts and locknuts. Use the set of holes shown in Figure 3.14.
4. Attach the winch mount to the frame with two 1/2' x 1-1/4" bolts and locknuts. Tighten securely.
5. Attach the cable return assembly to the tube with four 7/16" x 1" bolts and locknuts (Figure 3.15).
- ➔ 6. For 31' and 36' model augers, mount cable return bracket on mount corresponding to the gearbox location. [is it obvious which is the corresponding mount?]

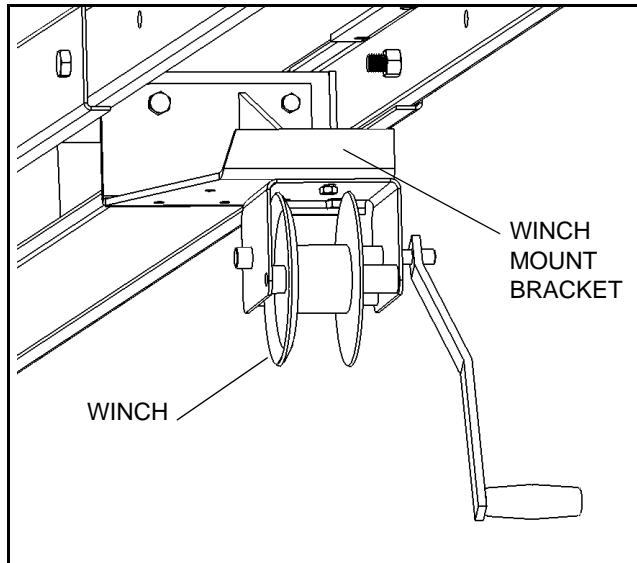

Figure 3.14 Winch Installation

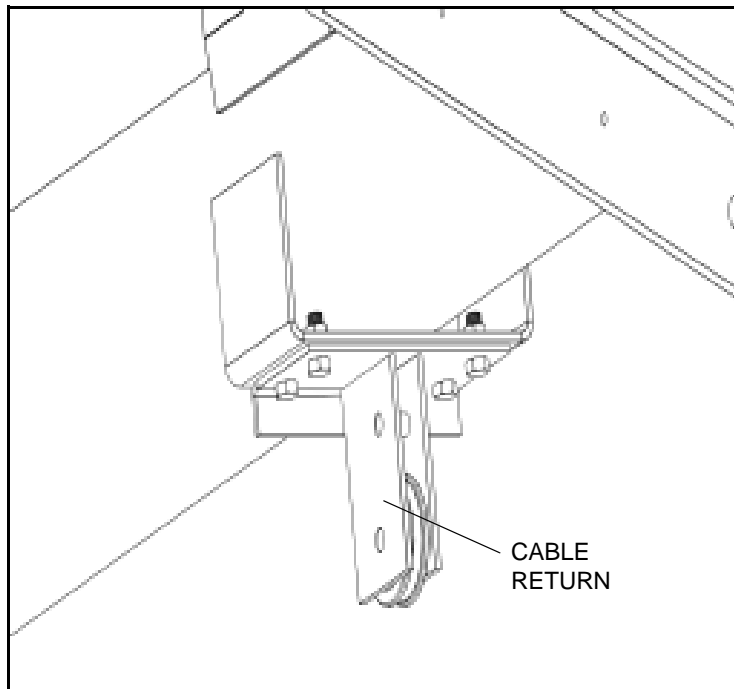

Figure 3.15 Cable Return Installation

7. Attach winch decal (#17109) provided on auger frame in a visible location close to the winch (Figure 3.16).

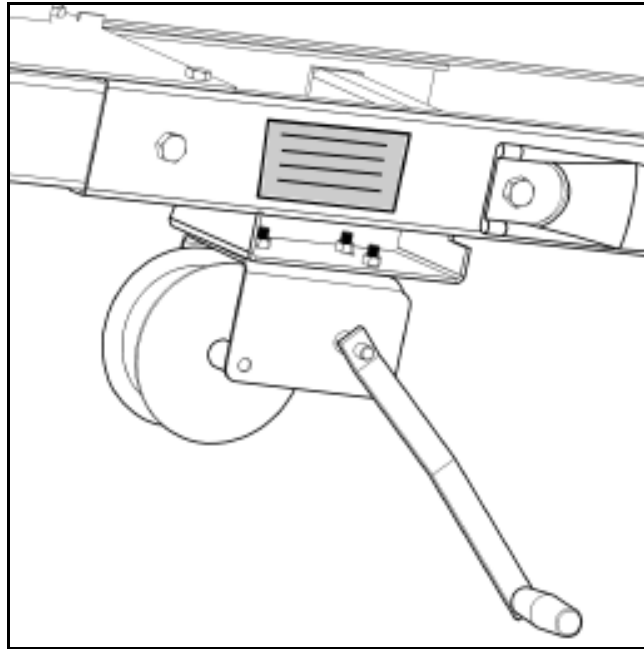



Figure 3.16

CAUTION	
	<p>After lowering auger, always turn winch handle clockwise at least two clicks to tighten brake lock</p> <p>Maintain control of winch handle at all times.</p> <p>Maintain light cable tension when in towing position.</p> <p>Do not put lubrication on brake discs.</p> <p>Check cable before each use. Replace if frayed or damaged.</p> <p>Make certain cable clamps are securely tightened.</p>

3.10. WINCH CABLE ROUTING

See Figure 3.17.

1. Coming from the bottom side of the winch, loop the cable around the bottom of the pulley in the cable return assembly.
2. From the top of the pulley, pull the cable up to the track shoe.
3. Loop the cable around the roller in the trackshoe, feeding it in the bottom of the roller and out the top.

4. From here, pull the cable back down to the cable return assembly. Loop the cable around the pin in the upper part of the cable return assembly. Loop so that the cable comes out on the top.
5. Wrap cable 1-1/2 times around the cable attach rod and secure with two 1/4" cable clamps. Position cable clamps as shown in .

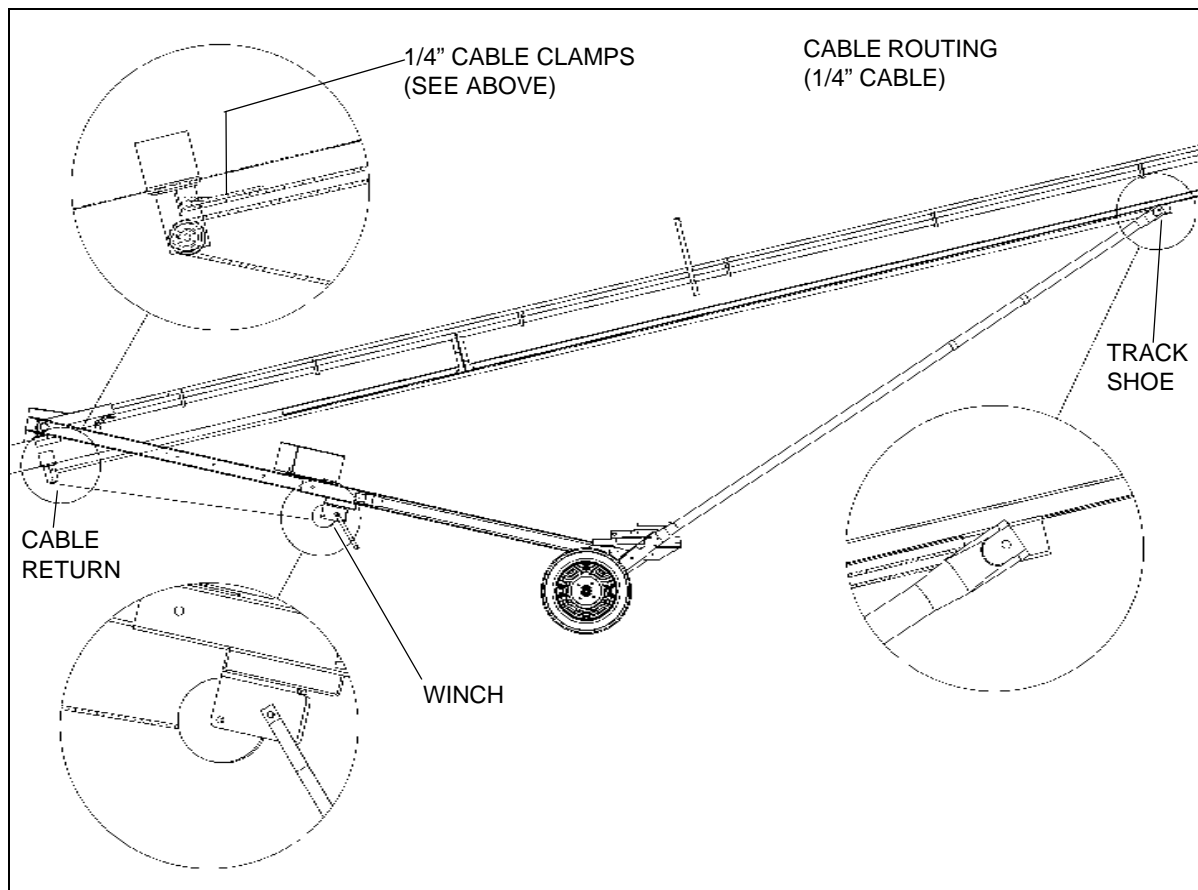
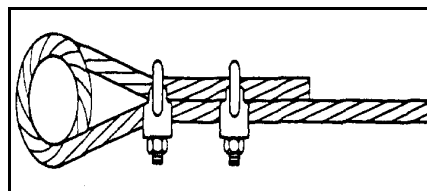

Figure 3.17 Winch Cable Installation

All augers have a lower angle-iron track stop. The cable must be threaded between track stop and auger tube so cable rests on top of the track stop.



Note: *Make certain cable is properly seated in cable pulley before raising auger.*

3.11. WINCH HANDLE

The TF-Series auger may use one of several different winch models. Before installing handle on the main winch assembly, check the model number stamped on winch housing and follow the correct set of instructions [[these instructions are for which winch?](#)].

CAUTION	
	Winch handle assembly must follow the instructions below. Improper assembly will result in sudden winch failure causing damage to equipment and/or personal injury.

1. Slide handle over flat sides of input shaft.
2. Fasten with 1/2" locknut (Figure 3.18).

Note: *Do not adjust or tamper with double locknut.*



Figure 3.18 Winch Handle Assembly

3.12. JACKSHAFT

1. Install the jackshaft assembly onto the jackshaft plate with four 3/8" x 1" carriage bolts and locknuts (Figure 3.19).

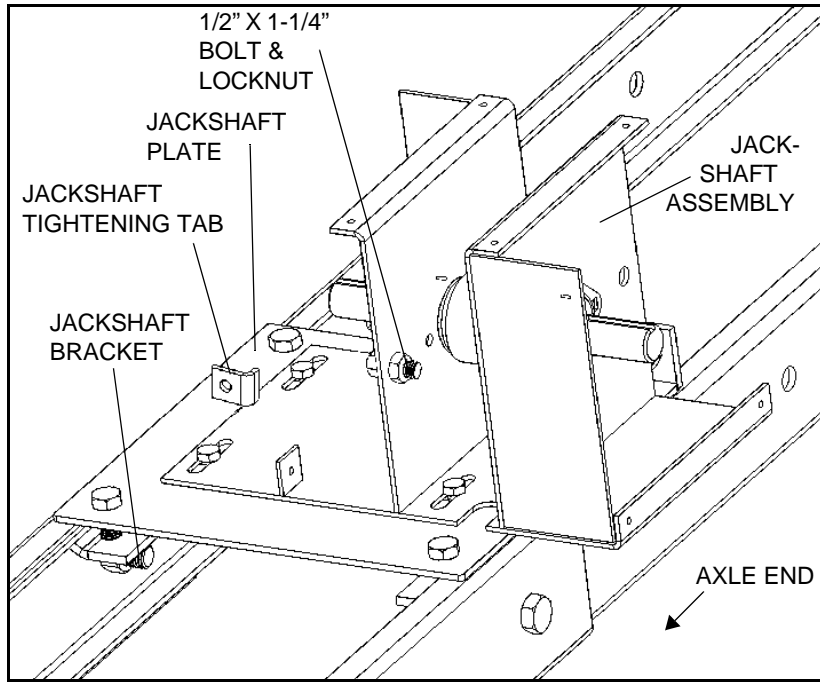

Figure 3.19 Jackshaft Installation

- ➔ 2. If using a gas engine drive, install 1/2" x 1-1/4" bolt onto jackshaft assembly before installing pulley (Figure 3.19).
3. Loosely install tensioner bolts through tabs in jackshaft plate and jackshaft assembly (Figure 3.20) before pulleys are installed.

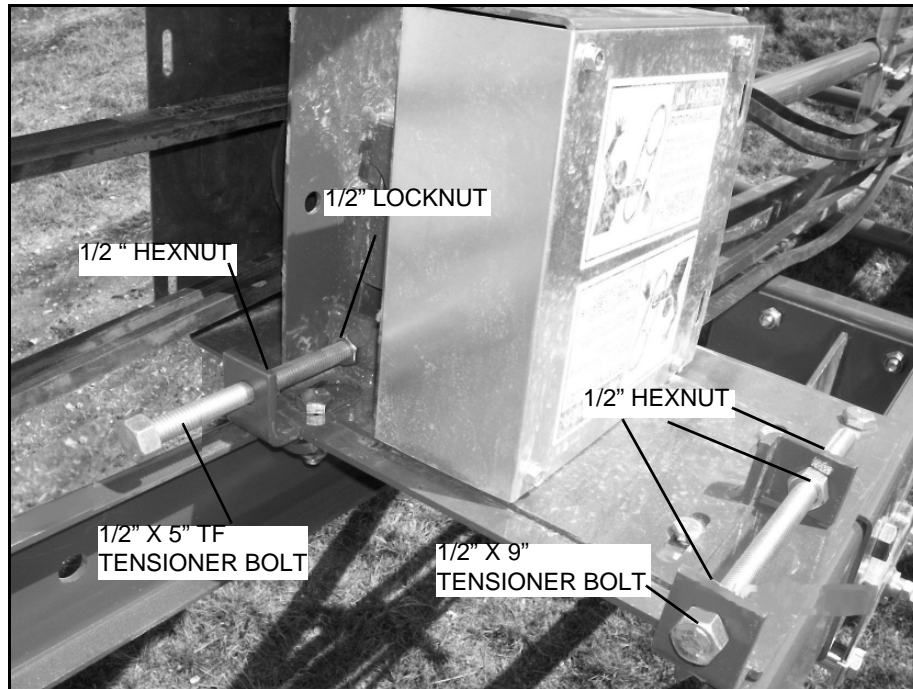

Figure 3.20 Tensioner Bolt

4. Install jackshaft plate onto frame using jackshaft brackets and four 1/2" x 1-1/2" carriage bolts and locknuts. Do not tighten.
5. Clean and remove paint from inside pulley hub and shaft. Slide pulley onto gearbox shaft with the hub outward using a 1/4" x 1-1/2" square key and secure using a set screw (see Table 3.3 for proper pulley sizes). Follow the same procedure for attaching the pulley to the jackshaft. [is set screw accurate here?]

Table 3.3 Gearbox to Jackshaft Pulley Sizing

Drive Kit	Pulley Diameter	
	Gearbox End	Jackshaft (output)
Gas Engine	8"	4"
EMD	8"	4"
PTO	8"	4"

6. Align pulleys by placing straight edge on outside of gearbox pulley and sighting along this edge towards jackshaft pulley. Adjust jackshaft pulley until it is in line with large gearbox pulley. Tighten set screws.

- Put belts on jackshaft pulley on the same side as gearbox pulley (see Table 3.4 for proper belt length).

Table 3.4 Jackshaft Belts

Auger	Upper Belt
8" / 10" x 31'	B124
8" / 10" x 36'	B132
8" / 10" x 41'	B166
8" x 46'	B166
8" x 51'	B160

- Slide jackshaft assembly on frame as far down as possible (by hand) to tighten belts. Square plate to frame. Tighten bolts on underside of plate to secure to frame.

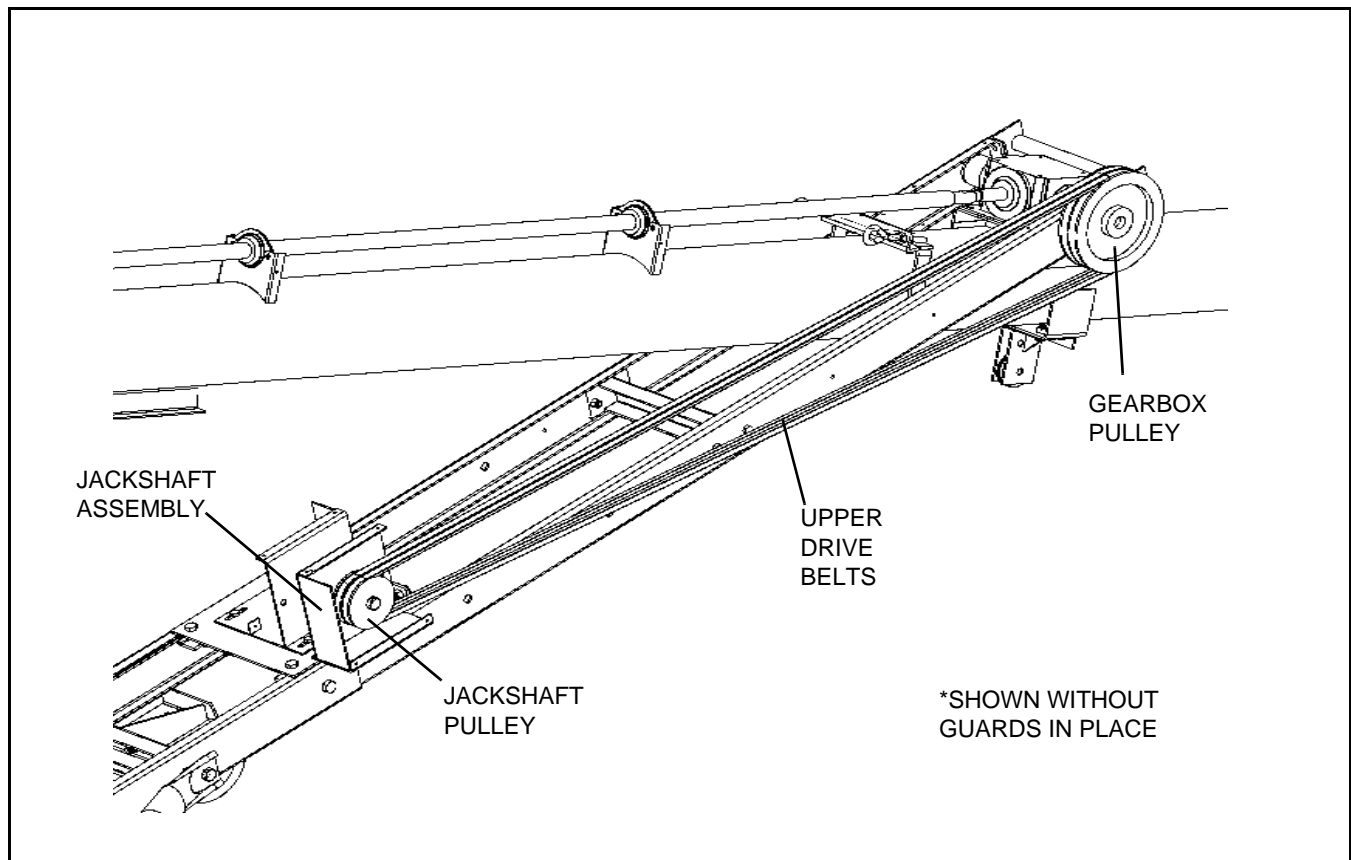

Figure 3.21 Jackshaft Belt Assembly

- Turn tensioner bolt to tighten belts. Lock with nut on bolt (Figure 3.22).
- Tighten bolts on jackshaft assembly to plate to secure in place.

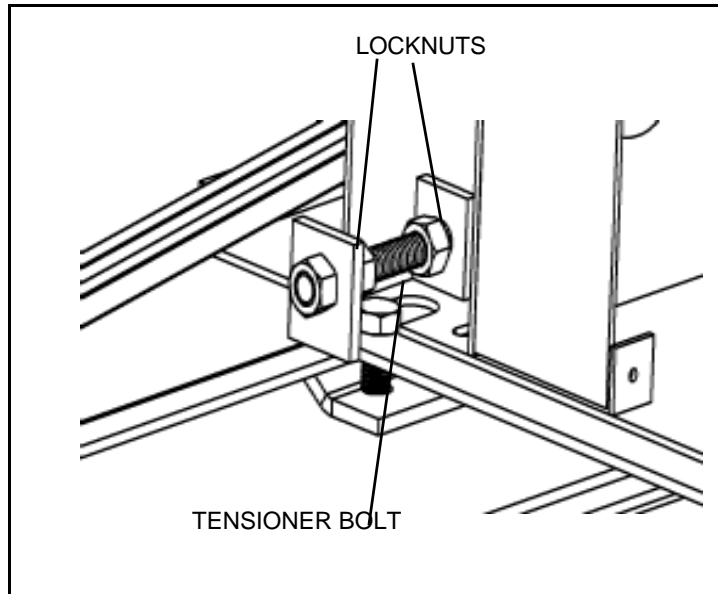

Figure 3.22 Jackshaft Tensioner Bolt

11. Install gearbox pulley guard and secure with four 1/4" x 1/2" flange head bolts (Figure 3.23).

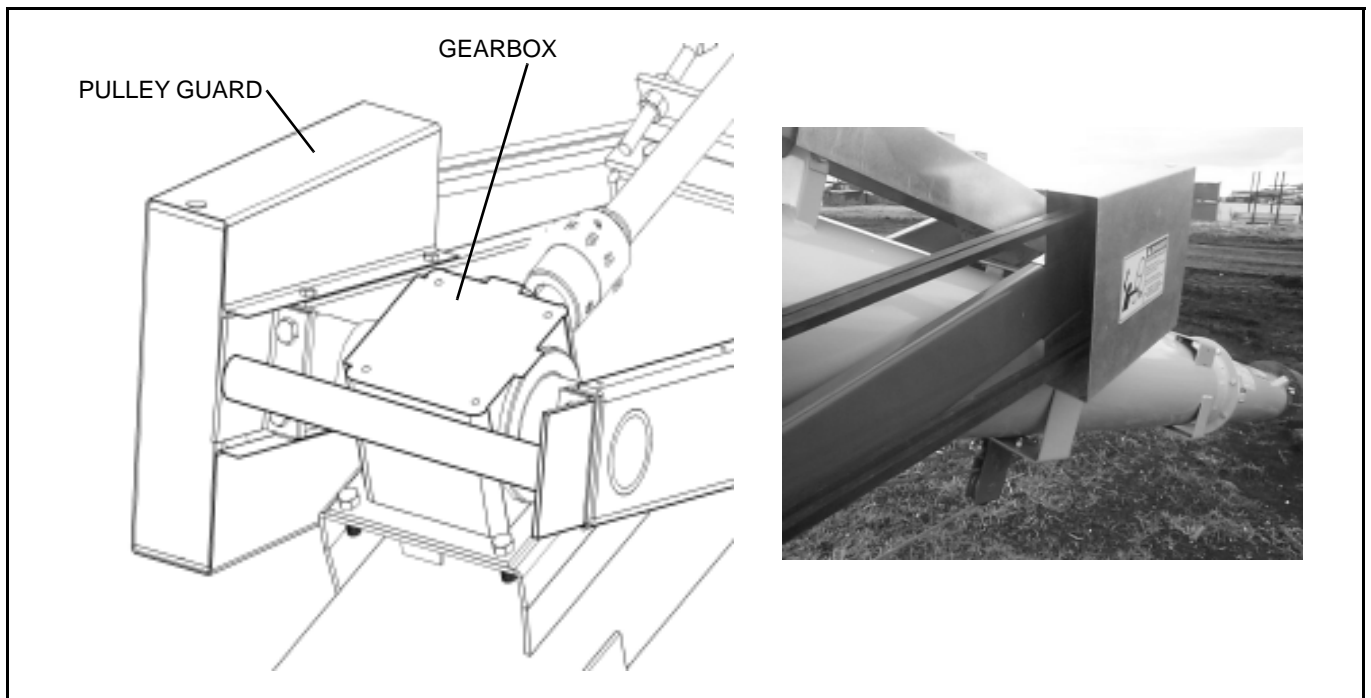

Figure 3.23 Gearbox Pulley Guard

3.13. GAS ENGINE MOTOR MOUNT (OPTIONAL)

1. Attach motor mount assembly to frame with two 5/8" x 1-1/2" bolts and locknuts. Do not fully tighten; this acts as a pivot point (Figure 3.25).
2. Attach short leveler bar (12") to tab on axle with the longer part towards intake of auger. Install a bushing and secure with one 7/16" x 1-3/4" bolt, locknut, and washer (on bushing side).

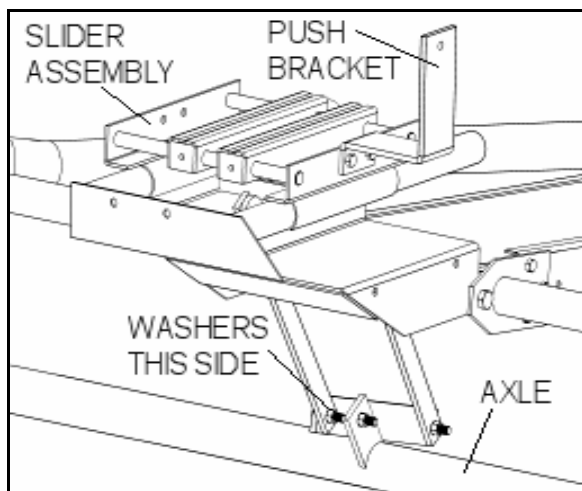

Figure 3.24 Motor Mount Installation

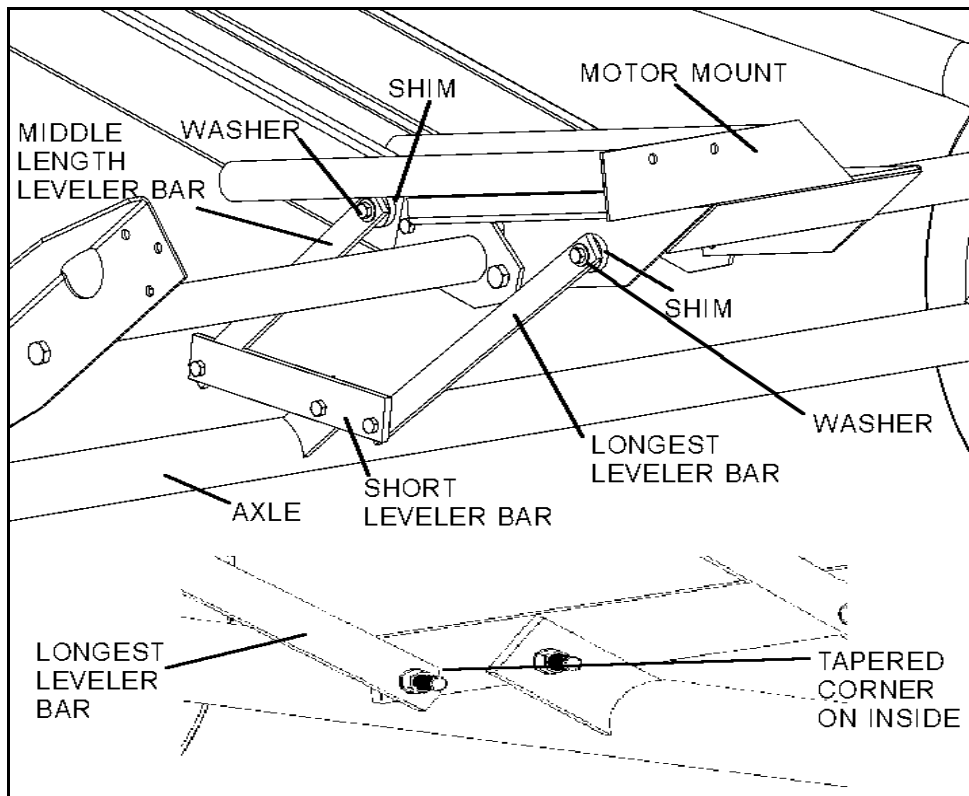

Figure 3.25 Leveler Bar Installation

3. Attach longest leveler bar (16-7/8") to motor mount frame and to the short leveler bar on the axle. Secure in both places using bushings and two 7/16" x 1-3/4" bolts, locknuts, and washers (on bushing side).
4. Attach remaining leveler bar (14-1/2") to hole in frame channel and to the leveler bar on the axle. Secure in both places using bushing and two 7/16" x 1-3/4" bolts, locknuts, and washers (on bushing side). Motor mount should sit level.
5. Attach motor mount push bracket to motor mount using two 7/16" x 1" bolts and locknuts (Figure 3.25).
6. If a gas tank kit is used, attach gasoline tank bracket to axle using two 7/16" x 1" bolts and locknuts (Figure 3.26).



Figure 3.26 Gas Tank Kit

7. Attach motor mount/gas tank connector bracket to the back of the motor mount and the back of the gas tank bracket and secure with four 7/16" x 1" bolts and locknuts (Figure 3.26).
8. Grease sliders on motor mount.
9. Install motor mount slider assembly onto motor mount (Figure 3.25).
10. Install engine onto motor mount sliders. Line up axis of shaft with hole in push bracket. Do not tighten at this point. **[when do you tighten?]**

[are steps 7-10 for just if you have a gas tank?]

3.14. BELT TENSIONER [SHOULD THIS GO ABOVE 4.12 (STANDARD FOR ALL) OR IS IT PART OF THE OPTIONAL GAS MOTOR MOUNT AND THEN BELOW THAT?]

1. Attach motor tensioner bar (motor end) to push bracket with one 7/16" x 1-1/4" bolt and locknut (Figure 3.27).

- Slide jackshaft tensioner bar into motor tensioner bar and attach to side of jackshaft assembly with one 1/2" x 1-1/4" bolt and locknut.

Note: Put a film of silicone lubricant between tensioner bars.

- Attach tensioner arm (over-center) to tab on tensioner bar with one 5/8" x 6-1/2" bolt and locknut. Install 5/8" rim washer between arm and tab.
- Attach U-bracket to tensioner bar using two, 3/8" x 2-1/2" bolts and locknuts. Leave loose for now. [leave loose until when?]

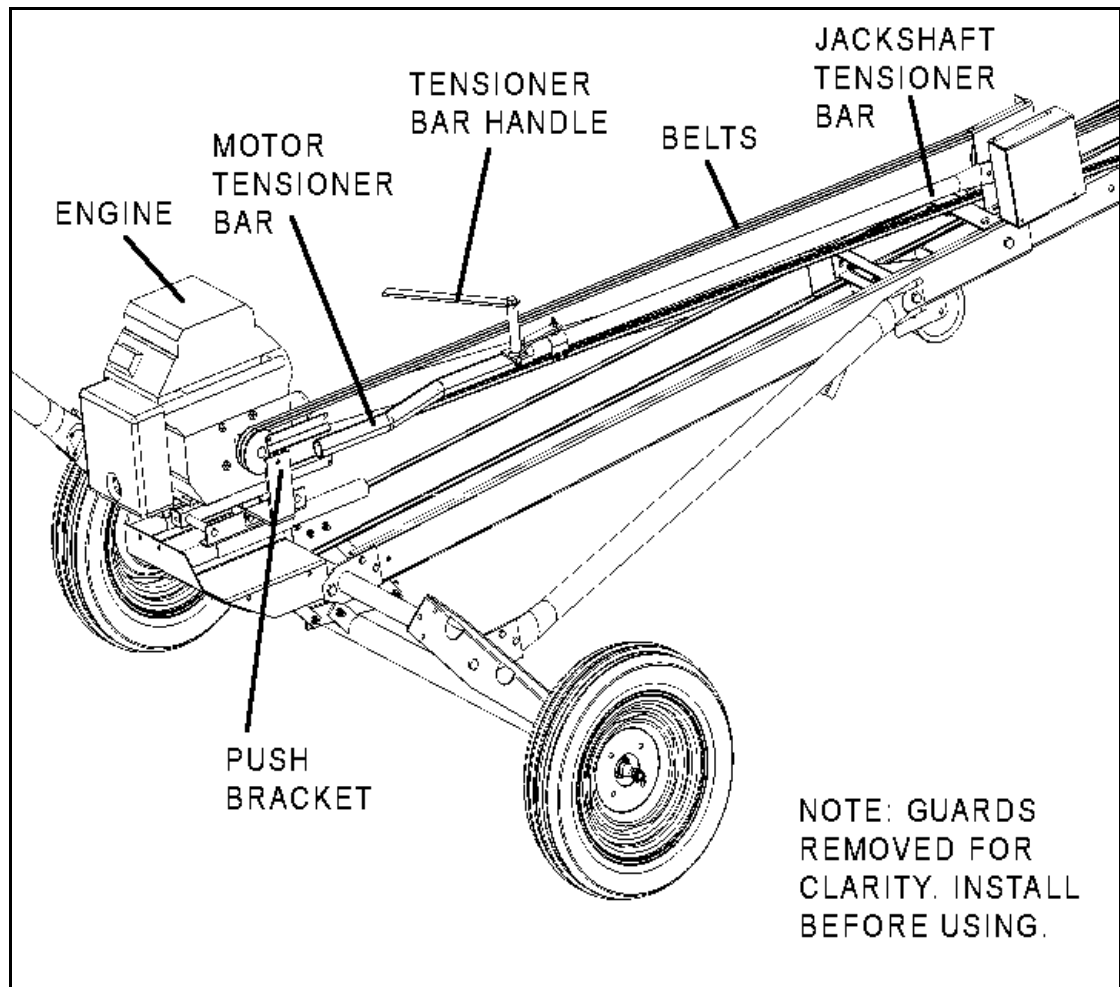

Figure 3.27 Gas Engine Belt Installation

- Complete tensioner arm assembly by attaching both arms using tensioner connector. Secure with a 7/16" x 1" bolt and locknut and a 7/16" [a 7/16" what?] on the threaded stud on the u-bracket assembly.

6. Clean inside of pulley hub and shaft and install pulley (8") onto motor mount side of jackshaft assembly with a 1/4" x 1-1/2" square key (see Table 3.5 for proper size). Secure with set screws (Figure 3.28).

Table 3.5 Jackshaft Input Pulleys

Drive Kit	Pulley Diameter	
	Drive End	Jackshaft (Input)
Gas Engine	4"	8"
EMD	4"	4"
PTO	15"	4"

Note: *This auger is designed to operate with a 4" pulley on the gas engine. If another size pulley is used, belts will not fit properly.*

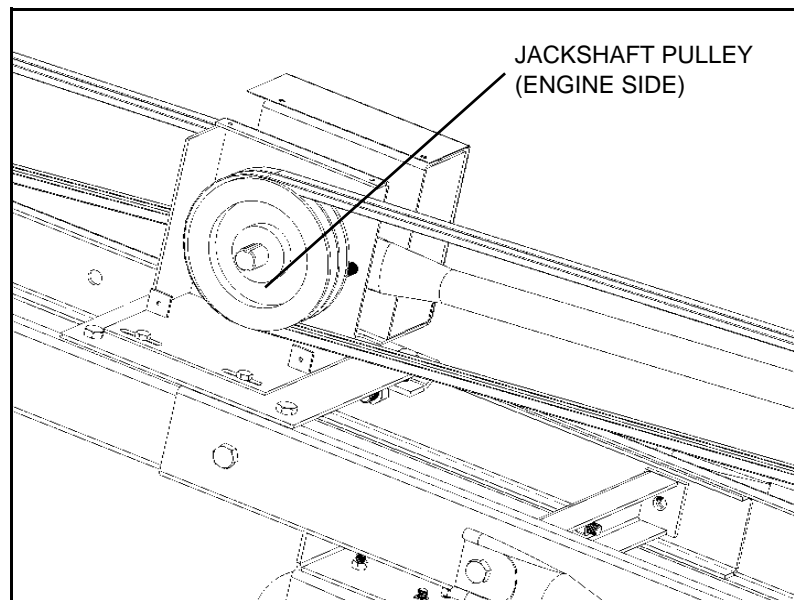

Figure 3.28 Jackshaft Input Pulley

7. Clean inside of pulley hub and shaft and install pulley (4", not included) onto engine (not included) using a 1/4" x 1-1/2" square key (see Table 3.5 for proper size). Secure with set screws (Figure 3.28).

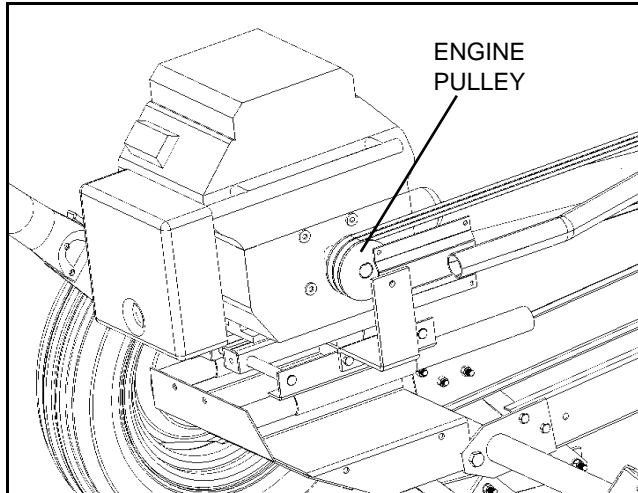

Figure 3.29 Gas Engine Pulley

8. Align pulleys by placing straight edge on outside of motor pulley and sighting along this edge towards jackshaft pulley.
 - Adjust motor laterally on motor mount sliders until belts are in line.
 - Secure using the bolts on motor mount sliders. Ensure gas engine output shaft is still aligned with push bracket. Adjust if required.
9. Install belts onto pulley on the engine side of the jackshaft and the engine (see Table 3.6 for proper lengths).

Table 3.6 Gas Engine Belts

Auger	Lower Belt (Gas Drive)
8" / 10" x 31'	B120
8" / 10" x 36'	B138
8" / 10" x 41'	B138
8" x 46'	B166
8" x 51'	B195

10. Move tensioner arm to open position. Adjust the location of the u-clamp on the tensioner bar so that it connects to the main tensioner assembly using the connecting bar.
11. Secure the u-clamp in place using hardware from step 4. The belts should tighten when the tensioner arm is rotated to the closed position. This may take some adjustment of location of the u-clamp.
12. Tighten snug only; these bolts act as pivot points.

Note: *The correct operating tension is the lowest tension at which the belts will not slip under peak load conditions.*

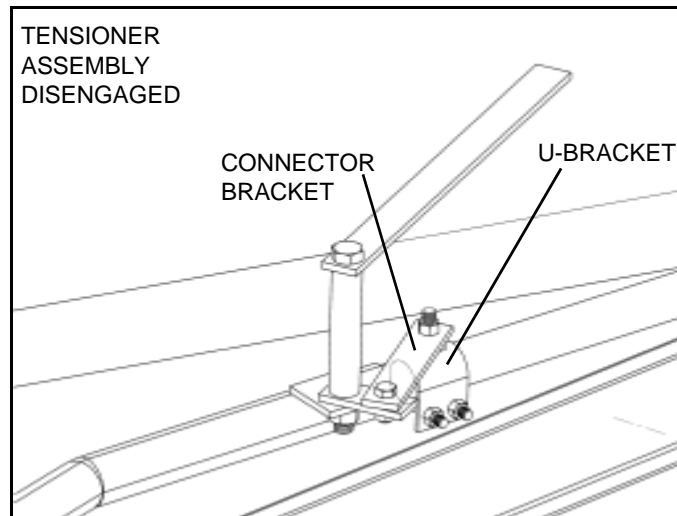

Figure 3.30 Tensioner Assembly (disengaged)

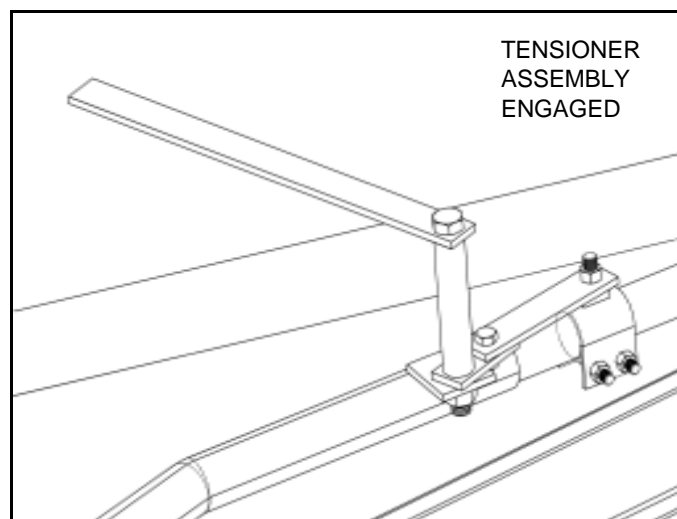

Figure 3.31 Tensioner Assembly (engaged)



13. The TF851 auger requires a belt guide assembly (Figure 3.32).

- Mount the belt guide assembly to the center of the push bar with one u-bolt (with two 3/8" whiznuts) and two 7/16" x 1" bolts and locknuts.
- With belts under tension, adjust the belt guides to within 1/8" to 1/4" of the belts to prevent excessive belt whip.

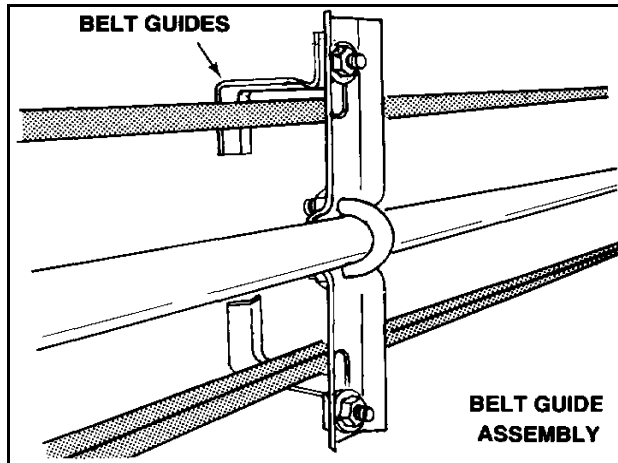

Figure 3.32

14. Install pulley guard over engine pulley. Install belt divider on inside of belt guard and secure both to push bar end plate using two 1/4" x 1" bolts, two, 1/4" x 1/2" bolts, and locknuts. The 2 longer bolts are required to secure the belt divider (Figure 3.33, 3.34, and 3.35).

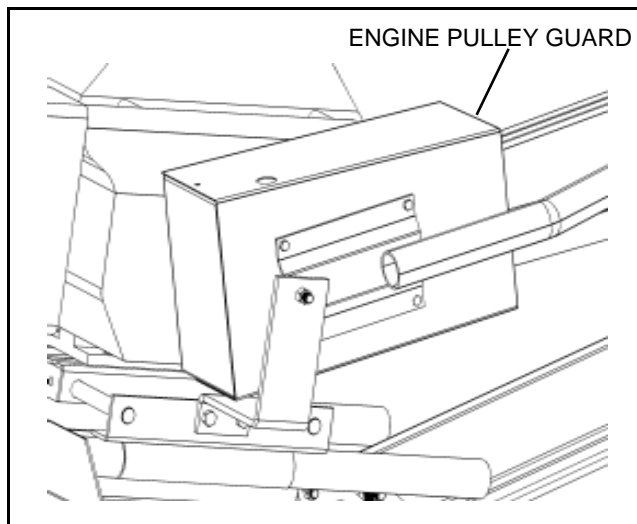

Figure 3.33 Gas Engine Pulley Guard



Figure 3.34 Gas Engine Pulley Guard

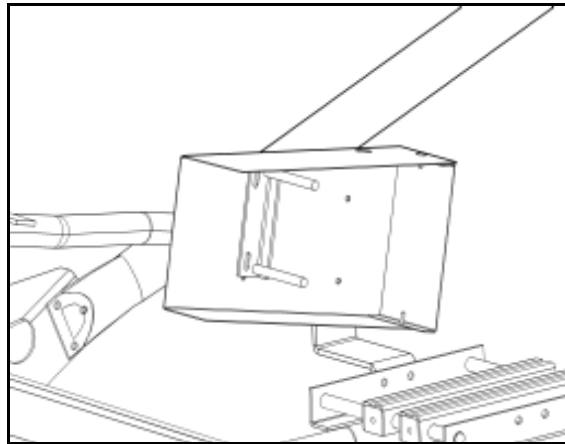

Figure 3.35 Belt Separator

15. Install pulley guards over both jack shaft pulleys and secure with four #14 x 5/8" self-tapping screws on each guard.

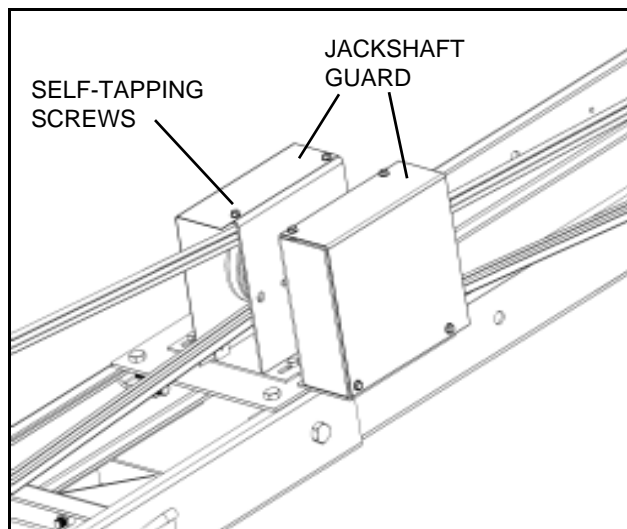

Figure 3.36 Jackshaft Pulley Guard

- ➔ 16. If needed, install battery holder (Figure 3.37) with a strap bolt and a 7/16" x 1" bolt and locknut. Secure battery with retaining bracket.



Figure 3.37 Battery Tray

WARNING	
	Keep battery or terminal covers in place and in good working order. Contact with positive terminal may cause sparks or electrical short which may cause fire or electrical burns.

WARNING	
	Exercise caution when handling batteries—they contain acid which can eat through clothing, burn skin, and cause blindness.

17. Connect battery cables as per instructions in the engine manual.

Important: Use battery cables with plastic or rubber terminal covers to protect against inadvertent contact with positive terminal.

Important: The gearbox has been filled at the factory (half full) with EP90 gear oil. Check oil level to make certain the gearbox is half full as required. Add oil if necessary. Do not use grease. *[does this need to be repeated here?]*

3.15. EMD DRIVE (OPTIONAL)

1. Attach EMD mount assembly to frame with two 5/8" x 1-1/2" bolts and locknuts. Do not fully tighten; this acts as a pivot point (Figure 3.38).

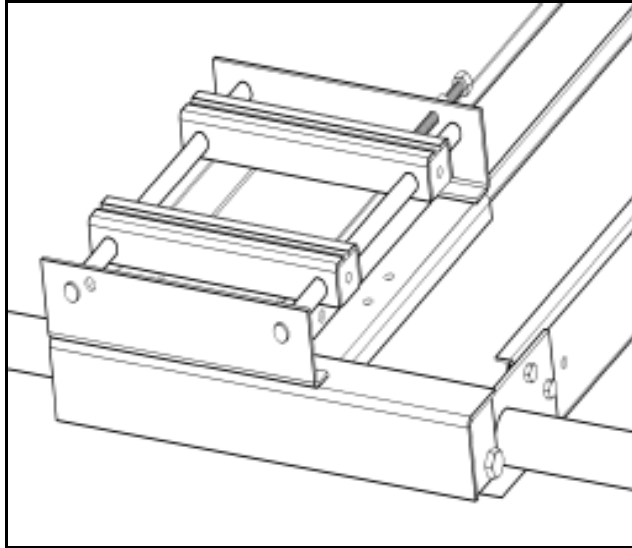

Figure 3.38 Electric Motor Mount Installation

2. Attach motor pulley guard bracket to motor mount base with two 7/16" x 1" bolts and locknuts.
3. Install electric motor onto motor mount sliders. Line up axis of shaft with hole in push bracket. Do not tighten yet.
4. Clean inside of pulley hub and shaft and install pulley (4") onto EMD mount side of jackshaft assembly using a 1/4" x 1-1/2" square key (see Table 3.5 for proper size). Secure with set screws.
5. Clean inside of pulley hub and shaft, then install pulley (4", not included) onto electric motor (not included) using a 1/4" x 1-1/2" square key (see Table 3.5 for proper size). Secure with set screws.
6. Align pulleys by placing straight edge on outside of motor pulley and sighting along this edge towards jackshaft pulley. Adjust motor laterally on motor mount sliders until belts are in line. Secure using the bolts on motor mount sliders.

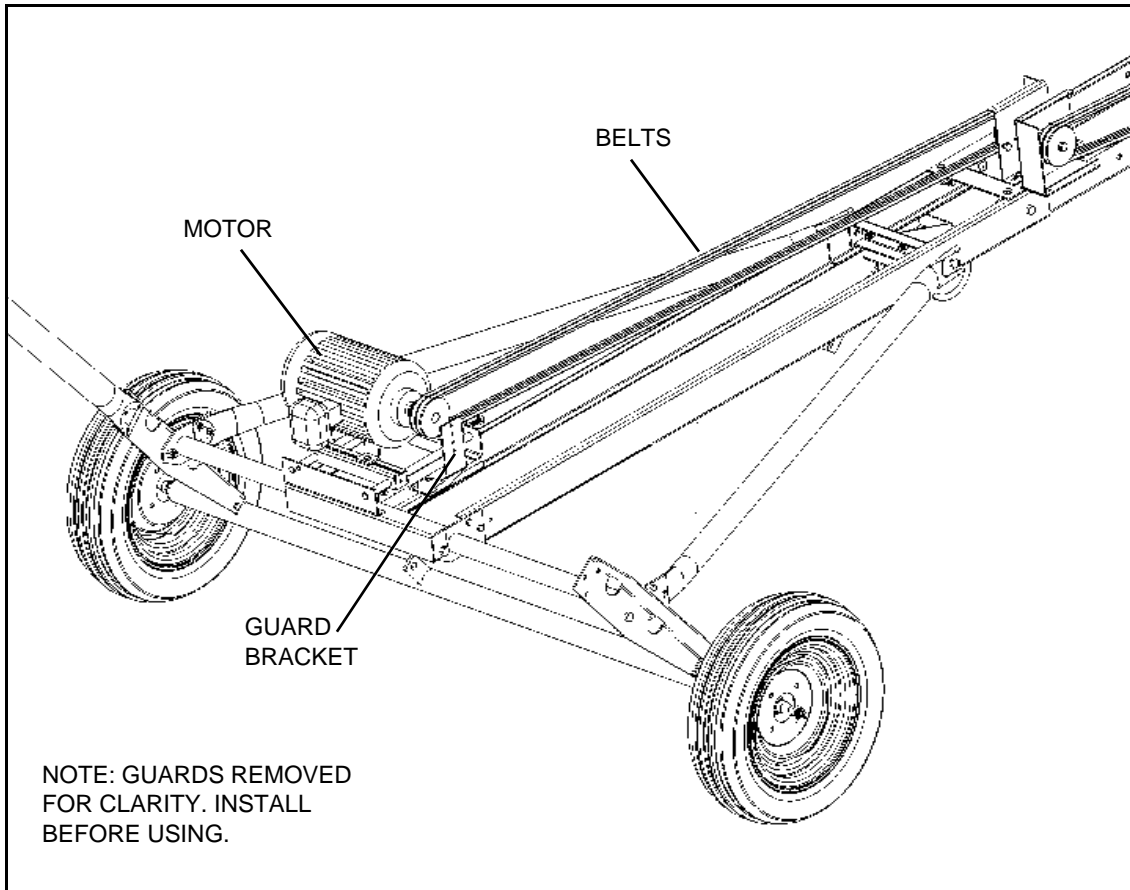

Figure 3.39 Electric Motor Belt Alignment

7. Install belts onto pulley on the motor side of the jackshaft and the motor pulley (see Table 3.7 for proper lengths).

Table 3.7 EMD Belts

Auger	Lower Belt (EMD Drive)
8" / 10" x 31'	B105
8" / 10" x 36'	B124
8" / 10" x 41'	B124
8" x 46'	B153
8" x 51'	B180

8. Tighten tensioner bolt on mount assembly to tighten belts. Lock with nut on tensioner bolt.
9. Install and secure pulley guard with two 1/4" x 1/2 flange head bolts and flange nuts (Figure 3.41).

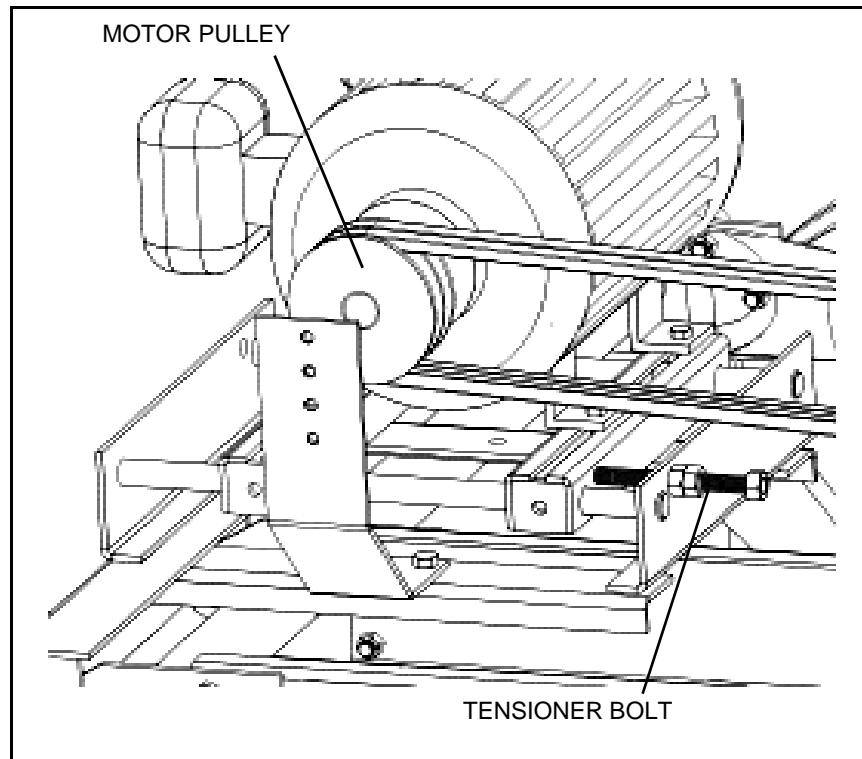

Figure 3.40 Electric Motor Belt Tensioning

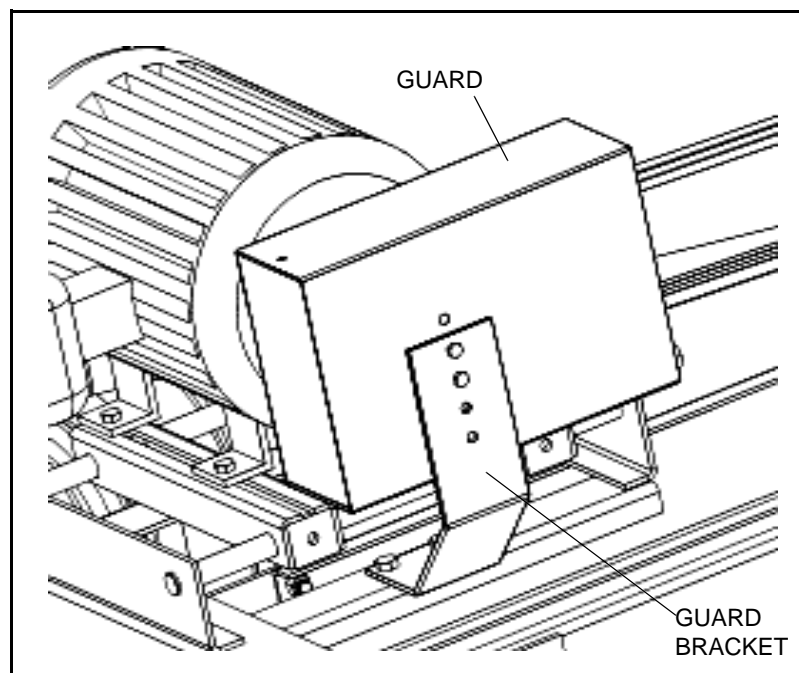

Figure 3.41 Electric Motor Pulley Guard

Important: *The gearbox has been filled at the factory (half full) with EP90 gear oil. Check oil level to make certain the gearbox is half full as required. Add oil if necessary. Do not use grease. [necessary again here?]*

When using an electric motor, follow these steps:

- The motor and controls should be installed by a qualified electrician in accordance with all local and national codes.
- Incorporate a magnetic starter to protect the motor.
- The motor must have a manual reset button.
- Locate reset and starter controls so that the operator has full view of the entire operation.
- Locate main power disconnect switch within reach from ground level to permit ready access in case of an emergency.
- A main power disconnect switch capable of being locked (in the off position only) must be provided.

See the Appendix for motor horsepower requirements.

3.16. PTO DRIVE (OPTIONAL)

The gearbox is factory-mounted to the gearbox plate with chain coupler in place. The PTO drive mount is mounted on the left side of the auger (facing the discharge end of the auger) as seen in Figure 3.43 .The PTO drive assembly is reversible.

If PTO drive mount must be accessible from the right side of the auger (facing the discharge end), flip gearbox and mount opposite. The jackshaft assembly and all pulleys, belts, and guards will also have to be mounted opposite.

1. Attach PTO mount base to auger frame with two 5/8" x 1-1/2 bolts and locknuts (Figure 3.42).

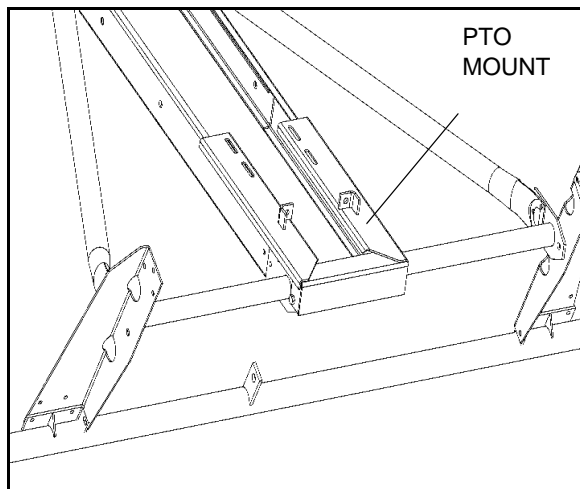

Figure 3.42 PTO Mount Installation

2. Attach PTO drive assembly to the PTO mount base with two 1/2" x 1-1/4" bolts and locknuts.
3. Attach the PTO jackshaft attach bracket to the lower reach arm with two 7/16" X 3-1/2" bolts and locknuts. Leave loose for now (Figure 3.43).

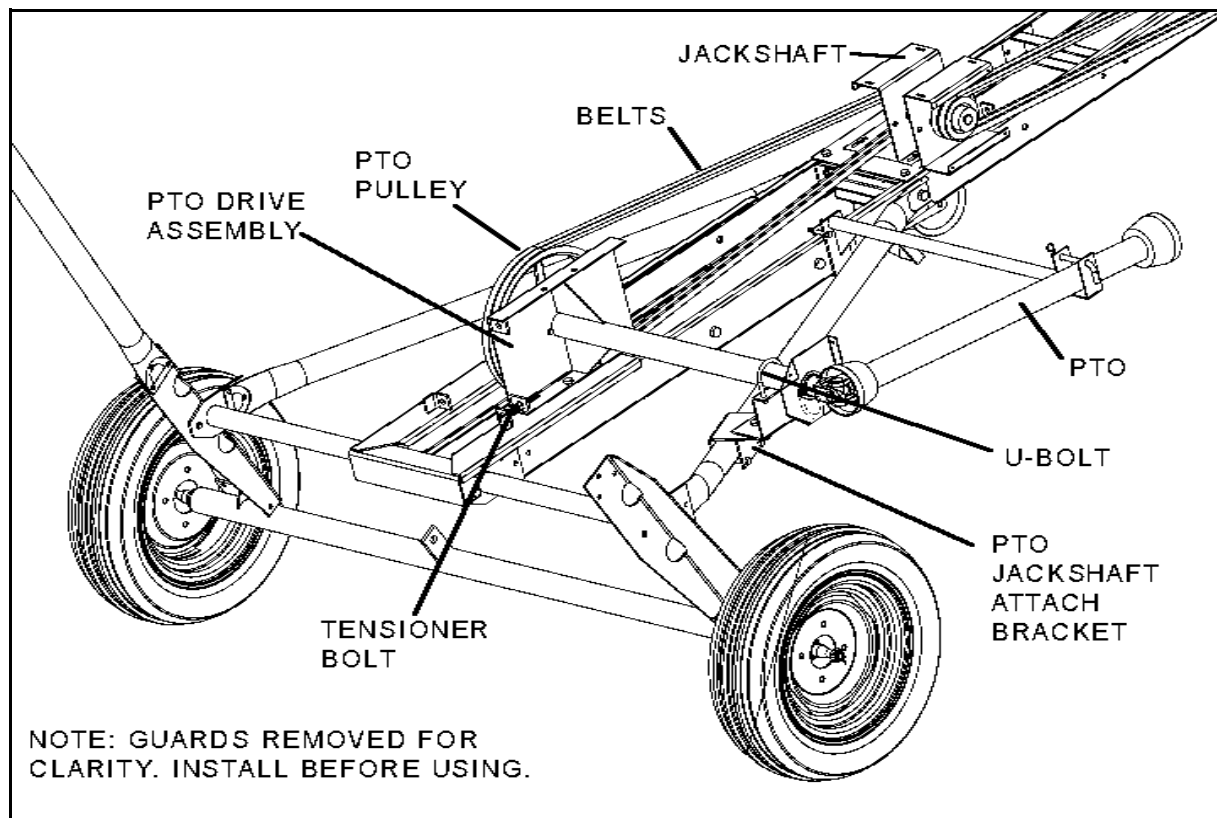

Figure 3.43 PTO Assembly Overview

4. Attach the PTO mount bracket to the PTO jackshaft attach bracket with one 1/2" x 1" bolt. Leave loose for now.
5. Install U-bolt over PTO tube and secure to the PTO mount bracket with two 3/8" locknuts.
6. Tighten all bolts left loose in the previous steps.
7. Clean inside pulley hub and shaft, then install PTO pulley (15") onto shaft of PTO drive assembly with a 1/4" x 1-1/2" square key (see Table 3.5 for proper size). Tighten set screws after alignment.
8. Clean inside pulley hub and jack shaft, then install the pulley (4") onto PTO mount side of jack shaft assembly with a 1/4" x 1-1/2" square key (see Table 3.5 for proper size). Tighten set screws after alignment.

- Place belt(s) on pulleys, align pulleys, and tighten set screws (see Table 3.5 for proper belt lengths).

Table 3.8 PTO Belts

Auger	Lower Belt (PTO Drive)
8" / 10" x 31'	B100
8" / 10" x 36'	B120
8" / 10" x 41'	B120
8" x 46'	B148
8" x 51'	B180

- Tighten tensioner bolt on PTO drive assembly to tighten belts. Back tighten nut on bolt to lock.
- Attach pulley guard to PTO drive assembly with two 1/4" x 1/2" bolts and locknuts on one side and self-tapping screws on the other (Figure 3.44).

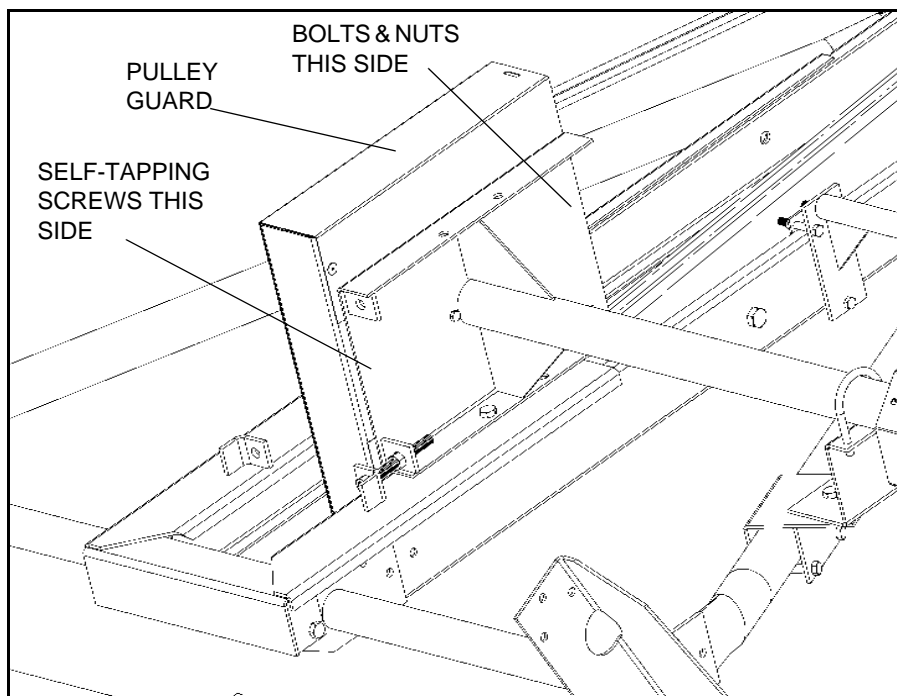

Figure 3.44 Pulley Guard Installation

- Clean paint and dirt from shaft on PTO drive assembly and PTO driveline ends, then attach using a 1/4" x 1-1/2" square key (Figure 3.45). **Tighten set screws.**

Note: *PTO driveline is non-separable type and must be disconnected from tractor before moving auger or tractor.*

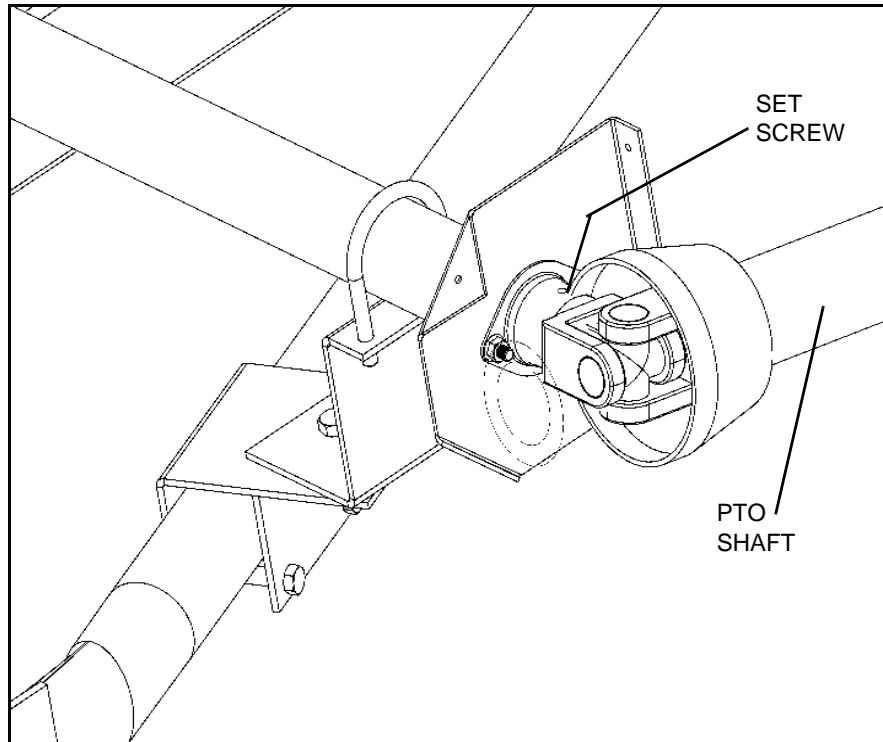

Figure 3.45 PTO Shaft Installation

13. Attach the PTO driveline transport saddle to frame with bracket and three 3/8" x 2-1/2" bolts and locknuts (Figure 3.46). Locate the saddle approximately 10" from end of PTO cover so that bracket does not interfere with any bolts on auger frame.

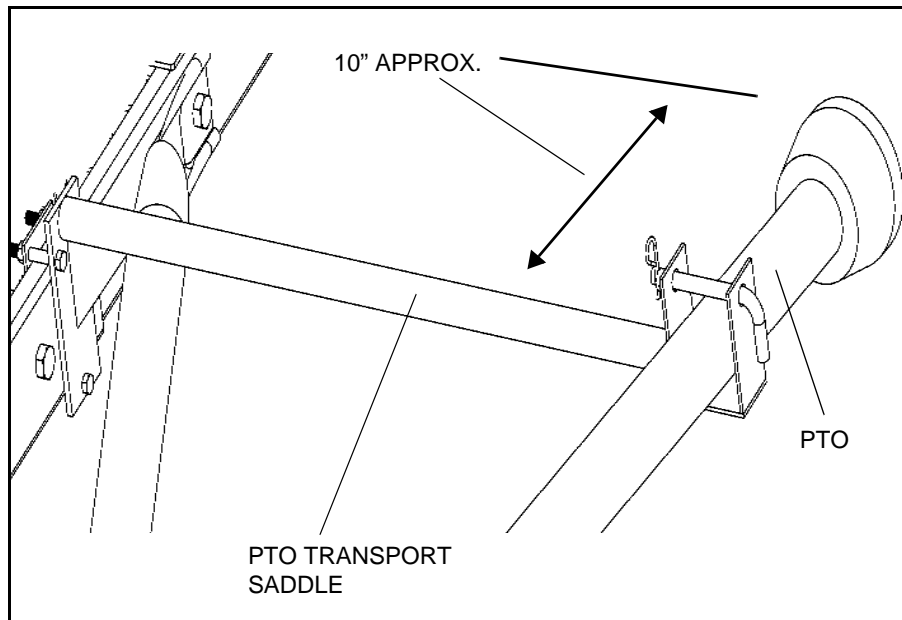

Figure 3.46 Transport Saddle Placement

14. Slide the drive shield over the PTO driveline and attach to the jackshaft with four 1/4" x 5/8" self-tapping screws (Figure 3.47).

Note: *The joint must be at auger intake side to allow placement of the PTO driveline into transport position.*

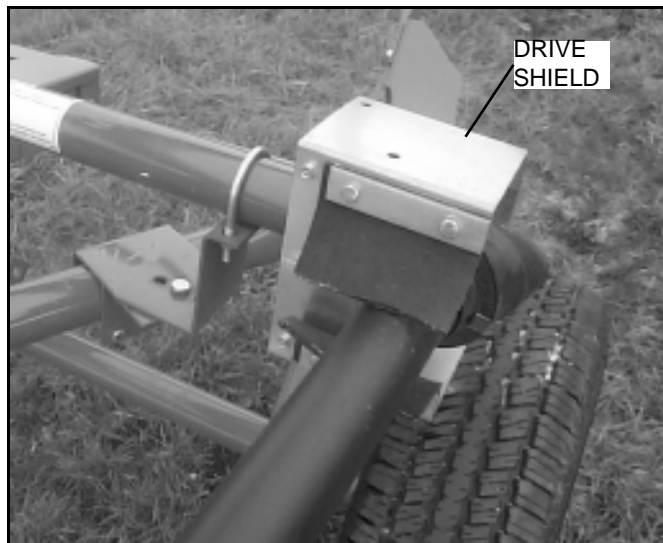

Figure 3.47 Drive Shield Installation

Important: *The gearbox has been filled at the factory (half full) with EP90 gear oil. Check oil level to make certain the gearbox is half full as required. Add oil if necessary. Do not use grease.*[necessary again?]**

3.17. UPPER HOUSING LUBRICATION

Fill enclosed upper drive housing with grease.

TF80	750 grams	26 oz
TF100	1100 grams	40 oz

For continuous use in extreme cold, semi-fluid arctic grease or heavy oil may be used.

3.18. PLASTIC MANUAL HOLDER

Before beginning installation, ensure that all winch / auger lift controls are locked in place. Shut down and/or lock out tractor.

1. Attach holder to the lower frame arms. Manual holder be accessible at all times, regardless if frame is up or down.
2. The manual holder's cap must face up (towards the intake end). Attach manual holder with supplied zip ties. Tighten the zip ties, securing the holder in place.

Note: *Where possible, attach the zip ties around a frame brace tab to prevent the manual holder from slipping down the lower frame arms.*

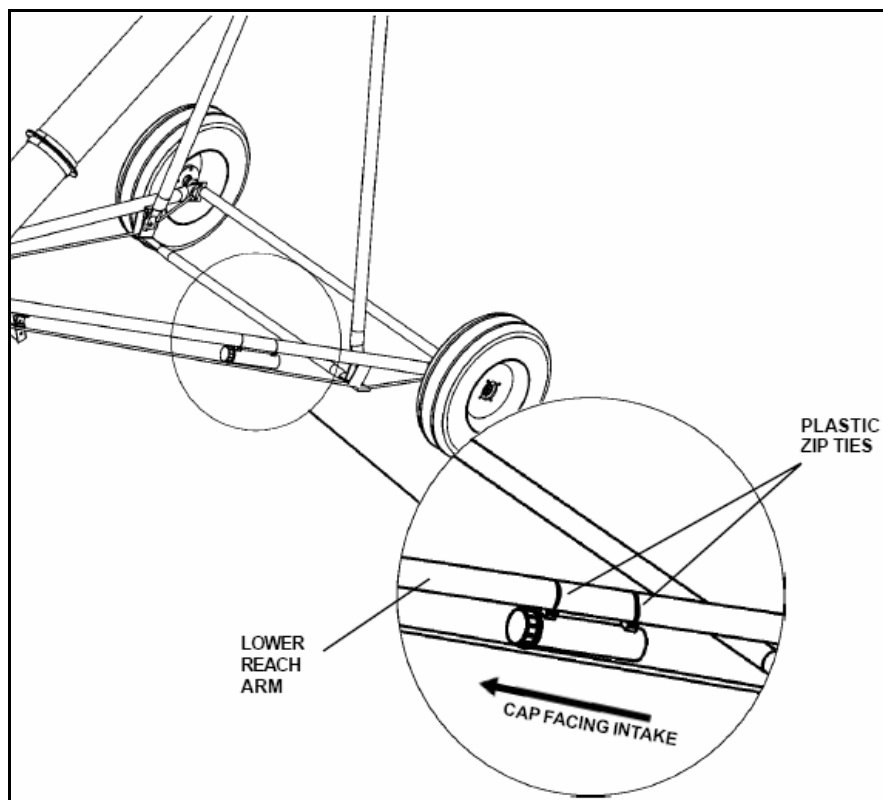

Figure 3.48

4. Transport & Placement

4.1. TRANSPORT PROCEDURE

Follow all safety precautions when transporting the auger and use a proper towing vehicle.

1. Place auger in full down position.
 - The lift-arm track shoe should be seated against the down position track stop with slight tension on the lift cable.
2. Lock winch: turn handle clockwise until 2 clicks are heard.
3. Place and secure hitch pin and safety chain. Thread safety chain through handle on the lower tube and wrapped around auger tube before attaching to the towing vehicle (Figure 4.1).

Note: *Use a type of hitch pin that will not allow auger to separate from towing vehicle.*

4. Place belt(s) under tension for transport.
5. Disconnect PTO driveline from tractor and secure in transport saddle.

CAUTION	
	If auger wheels are partially or fully buried in snow or grain, do not attempt to move auger until snow or grain has been cleared away from auger wheels. Failure to heed may cause damage to auger and/or personal injury.

6. Beware of overhead obstructions and electrical wires and devices. These augers have minimum clearances from 10'–13' (3.05 m–3.96 m) in normal transport position.

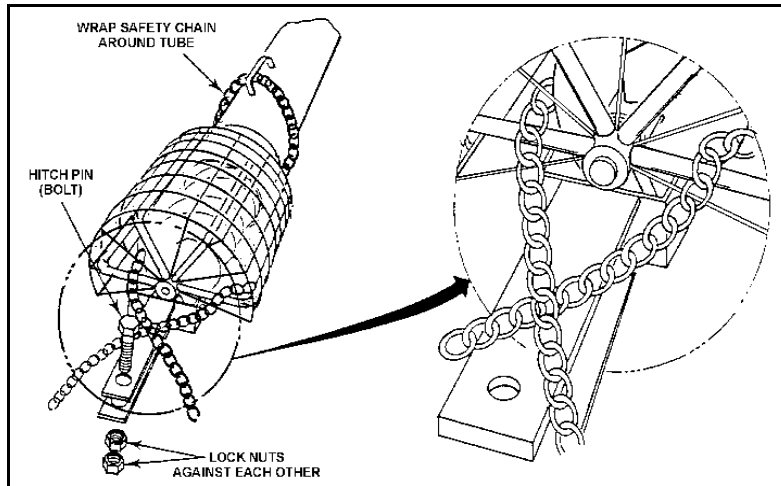

Figure 4.1

4.2. PLACEMENT PROCEDURE

WARNING



Auger must be hooked up to tractor for all operations, including transport, raising, placement, and augering grain.

1. Position and secure towing hitch.

Note: Use a type of hitch pin that will not allow auger to separate from towing vehicle.

2. To raise auger, turn winch handle clockwise. Use a firm grip on winch handle; do not release unless the ratchet pawl is fully engaged.

Important: Winch must make clicking sound when raising auger. If clicking stops, retain grip on handle, lower auger fully, and repair ratchet.

NOTICE

Do not turn winch handle counter-clockwise except when lowering auger, or severe damage will occur.

WARNING



Never attempt to increase height of auger by positioning wheels on lumber, blocks, or by any other means. To do so will result in damage to equipment and/or personal injury.

3. Move the auger into working position slowly, making sure that there is no one in the hazard zone. Do not unhitch and attempt to move auger by hand.
4. Once auger is in position, chock wheels on both sides and apply the park brake on the tractor (or chock its wheels as well) to prevent movement during operation.

Important: *When releasing auger from the towing vehicle, test the intake end for downward weight. Do not raise the intake end above drawbar height. When the intake end is elevated too high with auger in raised position, the balance of weight quickly transfers to the discharge end, causing it to upend. Ensure proper anchoring/support.*

5. When operating auger in the raised position, rest the discharge end lightly on the bin roof, or tie to bin to prevent wind from toppling auger.
6. Anchor and/or support auger during operation.
 - When lower half of auger empties of grain, the weight balance transfers to upper end of auger, which can cause upending.

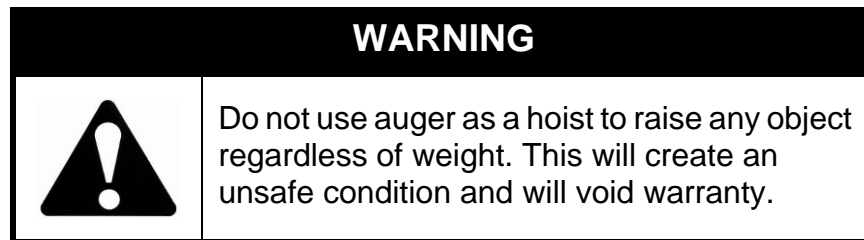

Note: *The PTO driveline is a non-separable type. Remove from tractor and secure in the transport saddle on auger before moving tractor away from auger.*

5. Operation

Operators must observe safety procedures at all times and follow the checklist before each start-up. To do otherwise is endangering life and limb and is a misuse of the equipment.

5.1. PRE-OPERATION CHECKLIST

Before operating auger each time, the operator must follow the checklist, which should confirm the following:

- All fasteners are secure as per assembly instructions.
- Drive belt(s) are not frayed or damaged.
- Drive belt(s) are properly adjusted and aligned.
- Lift cable is not frayed or damaged.
- Cable clamps are secure.
- Tube alignment is reasonably straight.
- Auger wheels are chocked, and if necessary, tractor wheels are chocked or the parking brake has been engaged.
- Intake area and discharge spout are free of obstructions.
- PTO driveline is connected and secure.
- PTO driveline guard rotates freely.

5.2. AUGER DRIVE & LOCKOUT PROCEDURE

For correct operation:

- pre-inspect drive system
- know how to shut down the system
- monitor system during operation

Drive Type	Before Operation	Lockout
Electric Motor	<p>Before starting motor, ensure</p> <ul style="list-style-type: none"> • motor is properly grounded • belt release lever is disengaged so that the belt(s) are released from lower motor pulley • pulley shields are in place and secure 	<p>The electric motor should be equipped with a main power disconnect switch capable of being locked in the off-position only. The switch should be in the locked position during shutdown or whenever maintenance is performed on the auger.</p> <ul style="list-style-type: none"> • If reset is required, disconnect all power before resetting motor.
Gas Engine	<p>Before starting engine, ensure</p> <ul style="list-style-type: none"> • gas tank is properly closed • belt release lever is disengaged so that the belt(s) are released from lower motor pulley • area surrounding auger is properly ventilated • pulley guards are in place and secure 	<p>Shut down and lock out power source.</p> <ol style="list-style-type: none"> a. For engines with a rope or crank start, remove the spark plug wire or the spark plug. b. For engines with an electric start, remove the ignition key, the spark plug wire, or the spark plug.
PTO Driveline	<p>Before starting, ensure</p> <ul style="list-style-type: none"> • PTO driveline is securely attached to the tractor and jack-haft • tractor park brake in engaged and/or wheels are chocked • you are not exceeding the maximum operating length of 64" (1610 mm) of the PTO driveline or maximum angle of 15° • PTO drive on the tractor is in the off position 	<p>Shut off tractor's engine and remove key from tractor.</p> <ul style="list-style-type: none"> • If removing key is impossible, remove PTO driveline from tractor.

5.3. OPERATING PROCEDURE

5.3.1. INITIAL START-UP

BREAK IN

1. Complete the checklist at the beginning of this chapter. If everything is satisfactory, prepare for a 30 minute operation at half speed.
2. Correctly position portable grain hopper secure it to the auger with both straps (where applicable).

Important: *Anchoring and/or support auger during operation. When lower half of auger empties of grain, the weight balance transfers to the upper end of auger, which can cause upending.*

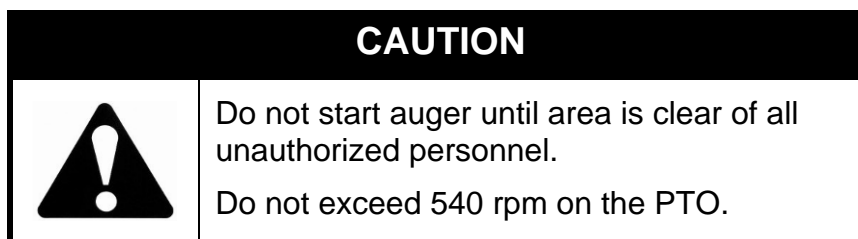

3. Start tractor and engage PTO driveline (or start electric motor if applicable), then feed grain to auger. If auger functions normally, check at varying speeds for a period of 30 minutes.

Important: *When starting auger for the first time, be prepared for an emergency shutdown in case of excessive vibration or noise. Note that auger may run rough until tube is polished.*

4. Upon completion of initial run, shutdown auger (see section below for more information on shutting down your auger).
5. Lock out tractor and conduct a complete inspection of auger following the checklist at the beginning of this chapter.

After the initial start-up and inspection, the auger should be shut down and inspected at least three times during the first 10 hours of operation.

Once auger is broken in, the checklist should be a part of the daily routine before operating auger.

5.3.2. OPERATING WITH A FULL LOAD

WARNING	
	Do not remove or open clean-out doors while auger is in operation. Do not operate if clean-out doors are removed.

- Monitor the auger during the actual operation for abnormal noises or vibrations.
- **If grain overflows** through safety discharge door, then the auger is loaded beyond its capacity; reduce volume of feed to intake hopper. Remember, auger capacity will decrease at steeper angles of operation.

5.3.3. SHUTDOWN

1. Near the end of a load, reduce the feed of grain and decrease auger speed (when possible) until auger is clear of all grain.
2. Disengage belt release and stop engine/motor, then disengage PTO.
3. Shut down and lock out power source.

EMERGENCY / FULL-TUBE RESTART:

1. If cleanout covers or safety doors have been opened or removed, close or replace them before restarting the unit.
2. If auger is full of grain, do not restart at full speed. Engage the belt release gradually until normal operating speed is reached.
3. If the auger is shut down for an emergency, lock out motor before correcting the problem.
 - If the problem is plugging, clear as much of the grain as possible using a piece of wood, vacuum cleaner, **[shop vac or grain vac?]** or other tool before restarting auger. **Do not reach in and use your hands** (see “Auger Drive & Lockout” above for lockout procedure.)

NOTICE
Starting the auger under load may result in damage to unit. Be sure there is no blockage.

5.3.4. LOWERING & COMPLETION

After operation, move auger to the next work area or to a storage area and clean out.

1. Clean entire work area.
2. Remove all supports and chocks.
3. Move auger out of working position and lower fully.

LOWERING [PLEASE CHECK TO SEE IF PROCEDURE IS ACCURATE]

1. Raise the intake feed hopper. Do not attempt to lift by hand.
 - Never operate auger with intake feed hopper in transport position. This will damage the universal joint.
2. For PTO drives: disconnect driveline from tractor before lowering.
3. Ensure area beneath auger is clear.
4. Turn winch counterclockwise to lower (there will be no clicking sound when lowering).
5. After lowering, turn handle clockwise until you hear 2 clicks to lock brake.
 - Use a firm grip on handle. Do not release unless the ratchet pawl is fully engaged.
 - The winch is designed for manual operation only.
 - When lowering, never continue to turn handle counterclockwise if the cable does not keep moving out under load. This will disengage the brake mechanism and create an unsafe condition. If this happens, winch in slack cable and correct problem.

Do not leave auger in raised position when not in use. Auger could drop rapidly due to a cable break.

4. Clean out auger.
 - a. Shut off tractor engine and lock out power.
 - b. If necessary, open cleanout cover on the boot and manually clean out grain with a piece of wood, vacuum cleaner, or other tool. Do not use hands.
 - c. Replace cleanout cover.
 - d. Winch intake feed hopper into transport position and clean out remaining grain using a piece of wood or other tool.
5. Prepare for transport and placement or storage (see appropriate chapters for more information).

6. Maintenance and Storage

6.1. GENERAL MAINTENANCE PROCEDURES

Please follow the guidelines below.

Area	Maintenance	Frequency
General	While auger is in use, observe the checklist in Section 5.1.	Daily
General	Check all operating, lifting, and transport components. Replace damaged or worn parts before using auger. <ul style="list-style-type: none"> • For replacement instructions, see Chapter 3. 	Regularly
Upper Chain Drive	Fill enclosed upper drive housing with grease. <ul style="list-style-type: none"> • TF80: 750 g / 26 oz • TF100: 1100g / 40 oz For continuous use in extreme cold. semi-fluid arctic grease or heavy oil may be used.	??
Belt Release and Motor Mount Sliders	Lubricate with silicone or light oil.	??
Lift Cable	Check and replace if frayed or damaged. Make sure cable clamps are secure.	Periodically
Intake Bushing	Grease.	Daily
Truss Cables	Adjust to keep auger tube reasonably straight (if equipped).	As necessary
Wheel Hubs	Repack with lithium-based grease.	Every 2–3 years
Tire Pressure	Check with a pressure gauge. Pressure should be maintained at 18–24 psi (124–165 kPa).	Monthly, or if it seems low
Belt Release	Keep film of silicone lubricant on motor mount pipes and sliding end of push bar for easier release of belt tension.	Often
Cable Pulleys	Oil.	As needed.

Area	Maintenance	Frequency
Winch	Keep a film of grease on gears.	Regularly
	Oil the bushings, drum shaft, and ratchet. <ul style="list-style-type: none"> • Take care not to get oil or grease on brake discs. Service winch with auger in fully lowered position and cable slack. 	Occasionally
	Replace brake discs if less than 1/16" thick.	As required
	Service winch with auger in fully lowered position and cable slack.	Regularly
PTO Driveline	Check shield and replace if damaged.	Regularly
	Lubricate both universal joints	After every 8 hours of operation.
	Lubricate the center portion of driveline (grease fitting is beneath shield) where applicable.	Yearly
Gearbox	Maintain oil level at half full (center of cross shaft) with EP90 lube oil. <ul style="list-style-type: none"> • Gearbox should be level when checking or refilling. • Do not overfill. 	Regularly
Drive Belts	Check and replace if frayed or damaged	Regularly
	Ensure tension is correct under load. <ul style="list-style-type: none"> • Correct operating tension is the lowest tension at which the belts will not slip under peak load conditions. 	Regularly

To replace drive shaft bearings: remove flange bolts, split one-piece wood bearing with chisel, then replace with new two-piece wood bearing and replace flanges.

TO CHANGE BELTS:

First, shut off and lock out all power!	Gas Engine Drive	Electric and PTO Drive
<p align="center">Lower Belts (jackshaft to engine, motor, or PTO)</p>	1. Remove jackshaft pulley guard.	1. Remove jackshaft pulley guard.
	2. Remove engine pulley guard if necessary.	2. Remove motor/PTO pulley guard.
	3. Disengage belt tensioner handle on belt tenion tube to loosen belts.	3. Unlock nut and loosen tensioner bolt on motor/PTO mount base.
	4. Remove old belts and replace (Table 3.4).	4. Remove old belts and replace (Table 3.4).
	5. Engage belt tensioner handle to tighten belts.	5. Tighten tensioner bolt on motor mount base and turn nut to lock in place.
	6. Replace guards.	6. Replace guards.
<p align="center">Upper Belts (jackshaft to gearbox)</p>	All Drives	
	1. To change upper belts, the lower belts must be loosened. Disengage belt tensioner or remove bottom belts.	
	2. Remove gearbox pulley guard and jackshaft pulley guard.	
	3. Turn tensioner bolt on jackshaft assembly to loosen belts.	
	4. Loosen 4 bolts on base of jackshaft assembly.	
	5. Remove and replace belts (Table 3.4).	
	6. Once belts are installed, slide the jackshaft assembly as far as possible by hand towards the discharge end of the auger. Tighten 4 bolts on base.	
	7. Tighten tensioner bolt to tighten belts. Lock in place with nut.	
	8. Replace pulley guards.	
9. Tension lower belts. The belt tensioner may need readjustment (see Section 3.14.).		

6.2. GENERAL STORAGE PROCEDURES

TO PROTECT AUGER IN STORAGE DURING THE OFF SEASON:

- Tow auger to storage area. Park and chock wheels.
- Lower the auger to the full down position with a slight tension on cable.
- Lubricate all grease fittings per maintenance procedures.
- Inspect auger for damage and note any repairs required. Order replacement parts from your dealer.
- Check tire pressure and inflate to 24 psi (165 kPa).

And where applicable:

- Remove battery and store in a cool, dry place. Recharge periodically as required.
- Drain gas tank.
- Cover engine/motor with plastic to protect from weather.
- Tow auger to storage area. Park and chock wheels.
- Clean and lightly lubricate the spline on PTO driveline.

TO PREPARE AUGER FOR USE AFTER STORAGE:

- Tow auger to worksite.
- Check tire pressure and inflate to 18-24 psi (124-165 kPa).
- Check oil level in gearbox and refill if needed, half full only. **Do not overfill.**
- On augers equipped with lubricated upper drive, check level of lubrication annually and add as needed. Refill to plug level.
- Replace battery in holder (where applicable). When recharging battery, follow the correct procedure as indicated in the battery manual.
- Replace any damaged parts.
- Conduct general maintenance procedures before using auger.

7. Troubleshooting

to be added

8. Appendix

8.1. HORSEPOWER REQUIREMENTS

Table 8.1 ^a

	8"		10"	
	Gas	Elec	Gas	Elec
31'	16	5	20	7.5-10
36'	16	5-7.5	20-25	10
41'	16	5-7.5	20-25	10-15
46'	18	7.5		
51'	18	7.5		

a. With dry grain. High moisture grain will require more horsepower.

8.2. TUBE DECAL LOCATIONS

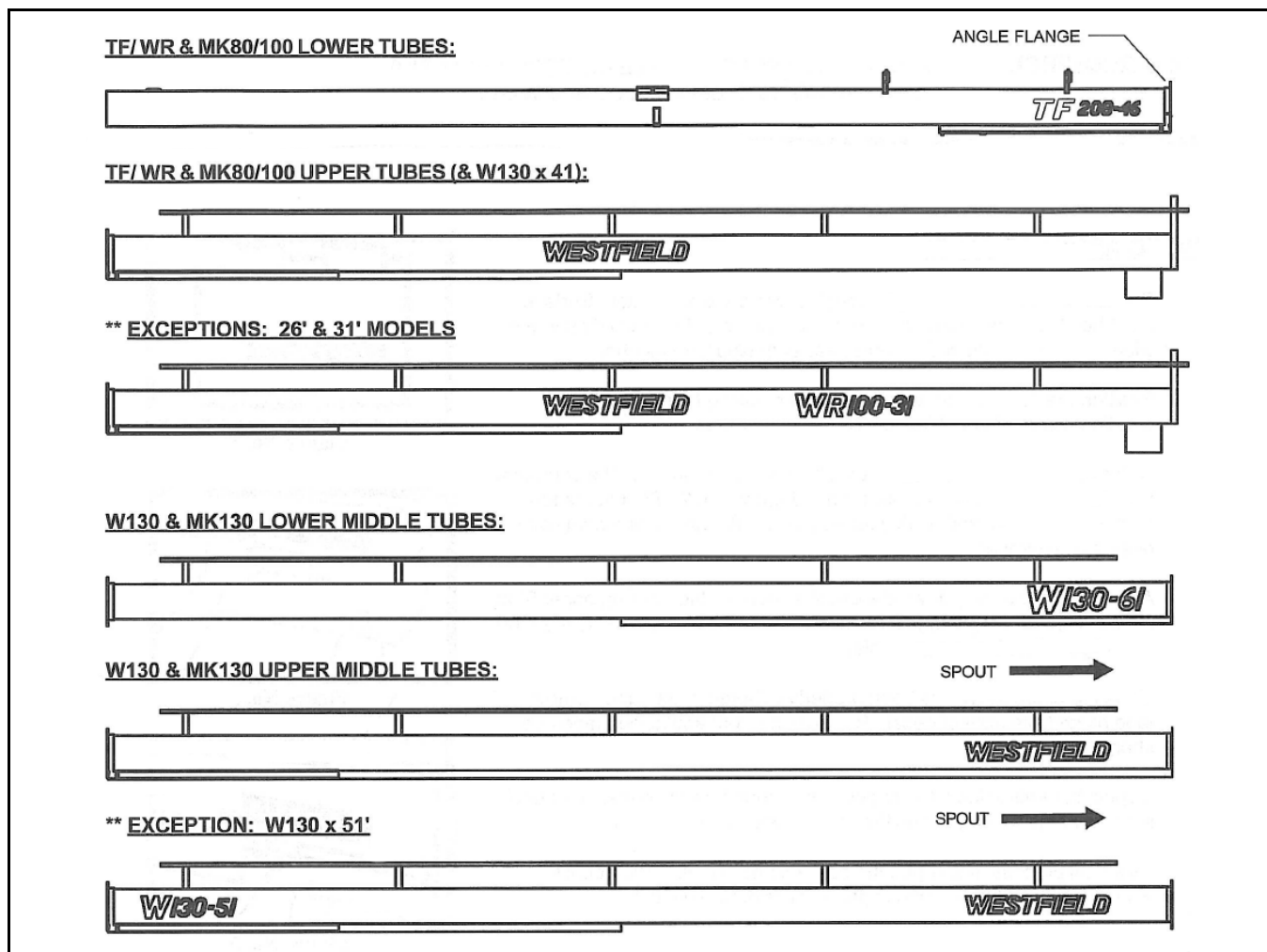

Figure 8.1

Important: Do not cover any existing safety or instruction decals with the model decals.

For most decal placement, follow the figure above. Apply decals to both sides of auger tube.

Lower Tubes: Place decals just below the angle flange, centered on the tube. Decals must be easily seen from the ground when auger assembly is complete. (For 36' augers, the model decal can be located in the center of the lower tube.)

Upper Tubes: Place Westfield decals in the center of the upper tube, where they are easily seen from the ground when auger assembly is complete. For the W130 & MK130 series, the Westfield decal is located at the top end of the upper middle tube.

WARRANTY

Westfield Industries Ltd. warrants products of its manufacture against defects in materials or workmanship under normal and reasonable use for a period of one year after date of delivery to the original purchaser.

Our obligation under this warranty is limited to repairing, replacing, or refunding defective part or parts which shall be returned to a distributor or a dealer of our Company, or to our factory, with transportation charges prepaid. This warranty does not obligate Westfield Industries Ltd. to bear the cost of labor in replacing defective parts. Any defects must be reported to the Company before the end of the one year period.

This warranty shall not apply to equipment which has been altered, improperly assembled, improperly maintained, or improperly repaired so as to adversely affect its performance. Westfield Industries Ltd. makes no express warranty of any character with respect to parts not of its manufacture.

The foregoing is in lieu of all other warranties, expressed or implied, including any warranties that extend beyond the description of the product, and the IMPLIED WARRANTY of MERCHANTABILITY is expressly excluded.

WESTFIELD INDUSTRIES LTD.

ROSENORT, MANITOBA

CANADA

ROG 1WO

WESTFIELD INDUSTRIES

P.O. Box 39

Rosenort, Manitoba, Canada R0G 1W0

Phone: (866) 467-7207 (Canada & USA)

Fax: (866) 768-4852

website: www.grainaugers.com

email: sales@grainaugers.com

Printed in Canada