



# MK FLEX AUGER

71' - 111'

## ASSEMBLY & OPERATION MANUAL



Read this manual before using product. Failure to follow instructions and safety precautions can result in serious injury, death, or property damage. Keep manual for future reference.

Part Number: 30650 R5

Revised: Apr/13



This product has been designed and constructed according to general engineering standards<sup>a</sup>. Other local regulations may apply and must be followed by the operator. We strongly recommend that all personnel associated with this equipment be trained in the correct operational and safety procedures required for this product. Periodic reviews of this manual with all employees should be standard practice. For your convenience, we include this sign-off sheet so you can record your periodic reviews.

<b>Date</b>	<b>Employee Signature</b>	<b>Employer Signature</b>

a. Standards include organizations such as the American Society of Agricultural and Biological Engineers, American National Standards Institute, Canadian Standards Association, International Organization for Standardization, and/or others.

# TABLE OF CONTENTS

<b>1. Introduction .....</b>	<b>5</b>
<b>2. Safety .....</b>	<b>7</b>
2.1. General Safety Information .....	7
2.2. Assembly Safety.....	8
2.3. Operation Safety .....	8
2.4. PTO Safety .....	11
2.5. Hydraulic Safety .....	11
2.6. Transport & Placement Safety .....	12
2.7. Maintenance Safety.....	13
2.8. Safety Decals .....	13
2.8.1. Decal Installation .....	13
2.8.2. Safety Decal Locations .....	14
<b>3. Assembly .....</b>	<b>19</b>
3.1. Tubes & Flighting .....	19
3.2. Discharge Spout & Thrust Adjuster .....	25
3.3. Flex Frame Components.....	26
3.4. Flex Tube Assembly.....	26
3.5. Connecting Flex Tube to Flex Frame .....	29
3.6. Track Shoe, Trackstop, & Lift-Assist Arm (71'–81').....	30
3.7. Track Shoe, Trackstop, & Lift-Assist Arm (91'–111').....	32
3.8. Adjustable Towbar.....	32
3.9. Truss (71'–81') .....	33
3.10. Truss (91'–111') .....	36
3.10.1. Cable Trussing (91'–111') .....	38
3.11. Transport Undercarriage (71'–81') .....	39
3.12. Transport Undercarriage (91'–111') .....	44
3.13. Lift Cables .....	47
3.13.1. MK Flex 71' .....	47
3.13.2. MK Flex 81'–111' .....	49
3.14. Hydraulic Hoses .....	50
3.14.1. MK Flex 71' .....	50
3.14.2. MK Flex 81' .....	51
3.14.3. MK Flex 91'–111' .....	53
3.15. PTO (CV) Driveline.....	54
3.16. Low Profile Hopper .....	55
3.16.1. Steering Assembly.....	57
3.16.2. Attaching Swing to Flex Auger .....	64
3.16.3. Hopper Lift Arm / Winch .....	64
3.16.4. Placing Hopper into Transport Position .....	67
3.17. Flex Auger Hydraulics .....	68
3.17.1. Open-to-Closed-Center Conversion .....	72

# TABLE OF CONTENTS

3.18. Hitch Jack .....	73
3.19. Auger-to-Tractor Hookup .....	73
3.19.1. PTO Driveline / Drawbar .....	73
3.19.2. Hydraulic Hose Couplers .....	75
3.20. Plastic Manual Holder .....	75
3.21. Model Decal Placement.....	77
<b>4. Transport &amp; Placement .....</b>	<b>79</b>
4.1. Transport Procedure.....	79
4.2. Placement Procedure .....	81
4.2.1. Axle Extension Procedure (81'/91'/111').....	84
<b>5. Operation .....</b>	<b>87</b>
5.1. Pre-Operational Checklist.....	87
5.2. Auger Drive & Lockout.....	87
5.3. Operating Procedure .....	88
5.3.1. Start-Up & Break-In .....	88
5.3.2. Operating with a Full Load.....	90
5.3.3. Shutdown.....	91
5.3.4. Lowering Auger.....	92
<b>6. Maintenance &amp; Storage.....</b>	<b>95</b>
6.1. General Maintenance Procedures.....	95
6.2. Mechanical Drive System .....	97
6.3. Storage .....	98
<b>7. Troubleshooting .....</b>	<b>99</b>
<b>8. Appendix.....</b>	<b>103</b>
8.1. Specifications .....	103
8.2. Lift Cylinder Hydraulics (81'/91'/111') .....	104
8.3. How to Charge the Lift System.....	104
8.3.1. Hydraulic Motor Notes .....	105
Warranty.....	107

# 1. Introduction

Thank you for purchasing a Westfield grain auger. Before using, please read this manual and understand the various features of the equipment and precautions for efficient and safe operation.

Keep this manual handy for frequent reference and to review with new personnel. A sign-off form is supplied on the inside front cover to record your safety reviews. Call your local distributor or dealer if you need assistance or additional information.

This manual should be regarded as part of the equipment. Suppliers of both new and second-hand equipment are advised to retain documentary evidence that this manual was provided with the machine.

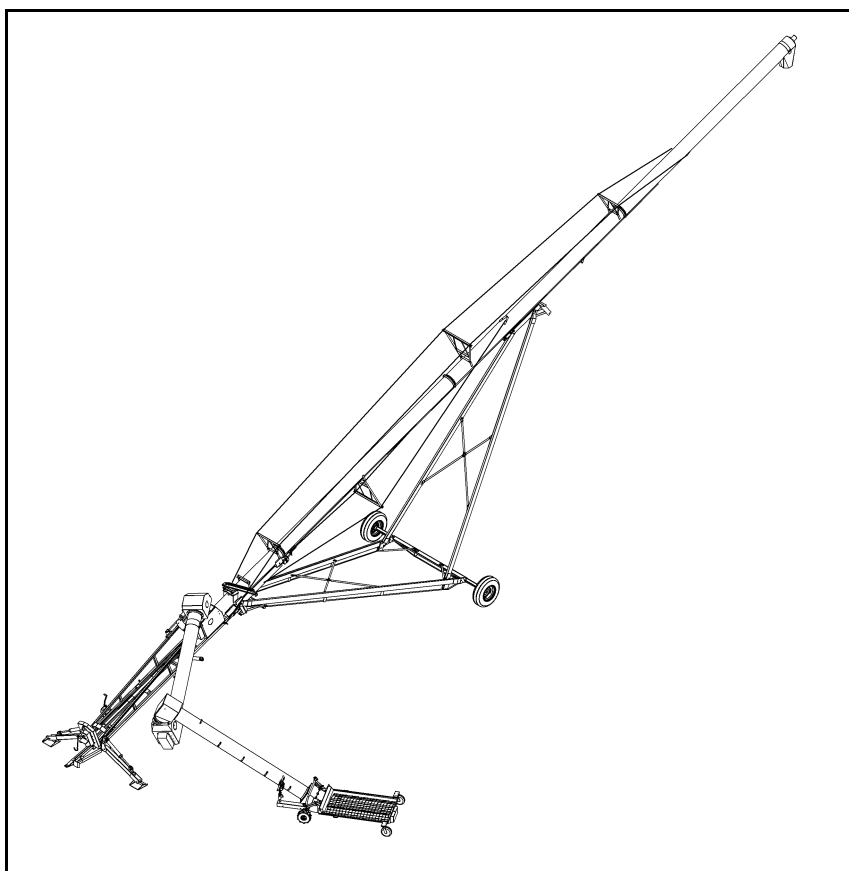

<b>Serial Number:</b>	
*Serial number is located on the lower tube.	



# 2. Safety

## 2.1. GENERAL SAFETY INFORMATION

---



The Safety Alert symbol identifies important safety messages on the product and in the manual. When you see this symbol, be alert to the possibility of personal injury or death. Follow the instructions in the safety messages.

Why is SAFETY important?

- Accidents disable and kill.
- Accidents cost.
- Accidents can be avoided.

**SIGNAL WORDS:** Note the use of the signal words **DANGER**, **WARNING**, **CAUTION**, and **NOTICE** with the safety messages. The appropriate signal word for each message has been selected using the definitions below as a guideline.

### DANGER



Indicates an imminently hazardous situation that, if not avoided, will result in serious injury or death.

### WARNING



Indicates a hazardous situation that, if not avoided, could result in serious injury or death.

### CAUTION



Indicates a hazardous situation that, if not avoided, may result in minor or moderate injury.

### NOTICE

Indicates a potentially hazardous situation that, if not avoided, may result in property damage.

**YOU** are responsible for the **SAFE** use and maintenance of your equipment. **YOU** must ensure that you and anyone else who is going to work around the equipment understands all procedures and related **SAFETY** information contained in this manual.

Remember, **YOU** are the key to safety. Good safety practices not only protect you, but also the people around you. Make these practices a working part of your safety program.

**Important:** *Below are general instructions that apply to all safety practices. Any instructions specific to a certain safety practice (e.g., Operational Safety), can be found in the appropriate section. Always read the complete instructional sections and not just these safety summaries before doing anything with the equipment.*



- It is the equipment owner, operator, and maintenance personnel's responsibility to read and understand **ALL** safety instructions, safety decals, and manuals and follow them when assembling, operating, or maintaining the equipment. All accidents can be avoided.
- Equipment owners must give instructions and review the information initially and annually with all personnel before allowing them to operate this product. Untrained users/operators expose themselves and bystanders to possible serious injury or death.
- Use this equipment for its intended purposes only.
- Do not modify the equipment in any way without written permission from the manufacturer. Unauthorized modification may impair the function and/or safety, and could affect the life of the equipment. Any unauthorized modification of the equipment voids the warranty.
- Do not allow any unauthorized person in the work area.

## 2.2. ASSEMBLY SAFETY

---

- Read and understand the instructions to get to know the sub-assemblies and hardware that make up the equipment before preceding to assemble the product.
- Do not take chances with safety. The components are large, heavy, and can be hard to handle. Always use the proper tools, stands, jacks, and hoists for the job.
- Always have two or more people assembling the equipment. Because of the weight, do not attempt assembly alone.

## 2.3. OPERATION SAFETY

---

- Have another trained person nearby who can shut down the auger in case of an accident. Always work with a second trained person around augers.
- Do not operate with any of the safety guards removed.
- Keep body, hair, and clothing away from moving parts. Stay away from intake during operation.
- Inspect lift cable before using auger. Replace if frayed or damaged. Make sure it is seated properly in cable sheaves and cable clamps are secure.



- Operate auger on level ground free of debris. If ground is uneven, anchor the auger to prevent tipping or upending.
- Augers are not insulated. Keep away from electrical lines. Electrocution can occur without direct contact.
- Support the discharge end and/or anchor the intake end before operating to prevent upending.
- Do not use auger as a hoist.
- Empty auger before raising or lowering.
- Lower auger at completion of operation or when not in use. Auger could drop rapidly if the cable breaks or if the hydraulics fail (where applicable).
- Do not operate auger with the service or cleanout doors open or unlatched.
- Do not get on or beneath auger when raising or lowering intake hitch jack, or when auger is supported by hitch jack.
- Do not operate auger with intake hopper in transport position. This will cause damage to the u-joint.

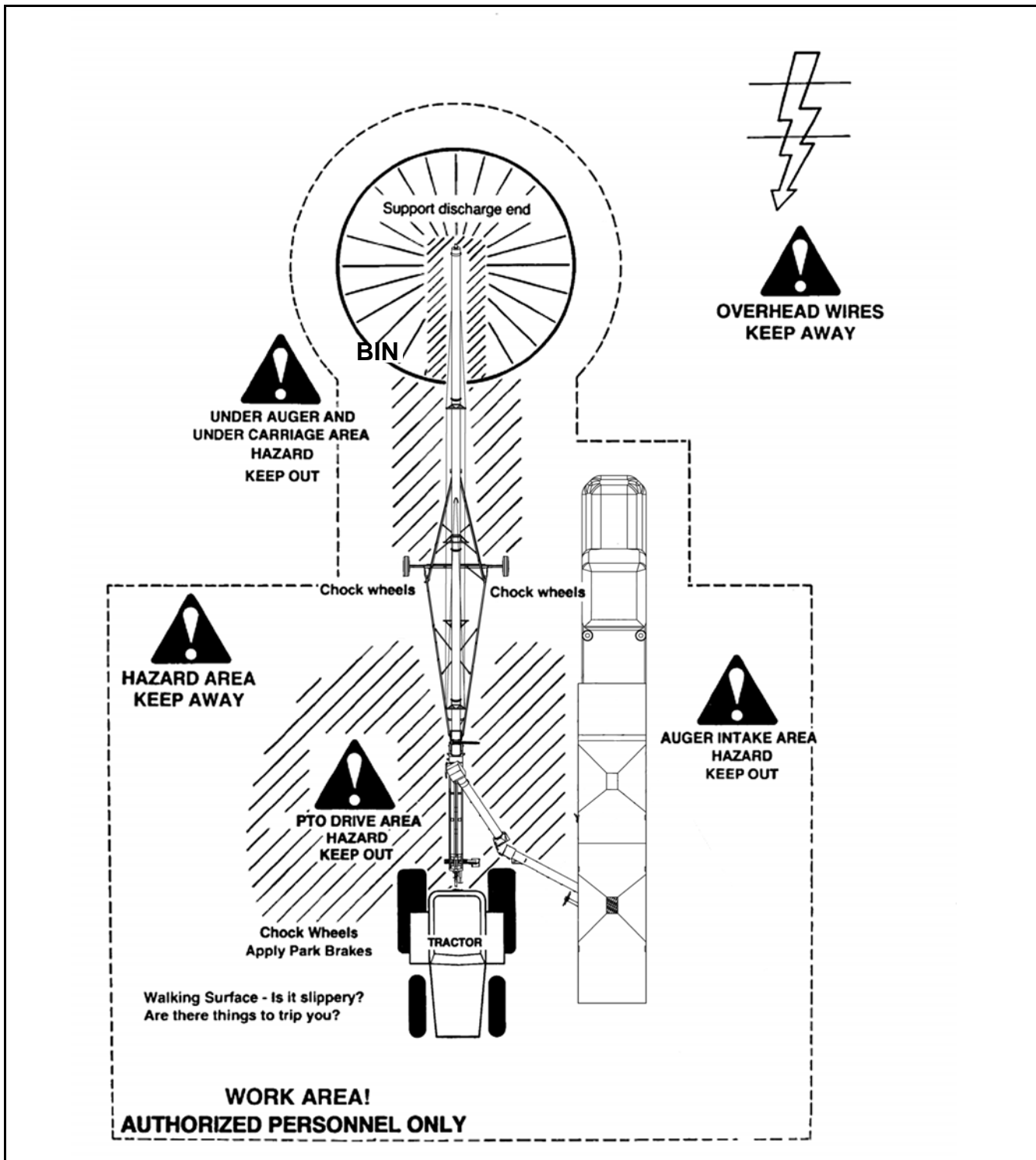

Figure 2.1

## 2.4. PTO SAFETY

---

- Never use a PTO driveline without a rotating shield in good working order.
- Ensure PTO driveline is securely attached at both ends before operating.
- Before starting tractor, turn power to PTO to the off position (where applicable).
- Keep body, hair, and clothing away from rotating PTO driveline.
- Ensure the PTO driveline shields turn freely on the PTO driveline.
- Do not exceed operating speed of 540 rpm.
- Keep u-joint angles small and equal. Do not exceed recommended operating length for PTO driveline.

## 2.5. HYDRAULIC SAFETY

---

- Wear proper hand and face protection when searching for hydraulic leaks. Escaping fluid under pressure can penetrate the skin, causing serious injury like gangrene. In case of accident, see a doctor immediately.
- Fluid leaks in the hydraulic lift cylinders or hoses will allow the auger to lower inadvertently. Repair all leaks and breaks immediately. Rupture could cause damage and/or personal injury.
- A hydraulic lift is faster than a conventional hand crank—always clear area of personnel before raising or lowering.
- Do not disconnect hydraulic couplers when hydraulic system is pressurized. For the correct procedure, consult this manual or your tractor manual.
- Relieve pressure before unhooking hydraulic lines.
- Inspect hydraulic fittings and hoses for damage on a daily basis. Repair if damaged.
- Ensure that the hydraulic line(s) is (are) properly connected and secure.
- Keep hydraulic line(s) away from moving parts.
- Clean connections before connecting to equipment.

## 2.6. TRANSPORT & PLACEMENT SAFETY

- Transport auger in full down position with slight tension on cable.
- Properly place hitch pin and securely attach safety chain. Use a type of hitch pin that will not allow auger to separate from towing vehicle.
- Always attach an SMV (slow moving vehicle) sign before transporting auger. Equip the auger with the necessary lights for transportation where required by law. Always use hazard warning flashers on the tractor/towing vehicle when transporting, unless prohibited by law.
- Always travel at a safe speed, never exceeding 15 mph (24 km/hr). Reduce speed on rough surfaces and be cautious when turning corners or meeting traffic.
- Before raising/lowering/moving the auger, make sure the area around the auger is clear of obstructions and/or untrained personnel. Never allow anyone to stand on or beneath auger while transporting or placing auger.
- Do not transport auger on slopes greater than 20°.
- Wheels must be free to move when raising or lowering auger.
- Never attempt to move auger manually. To do so will result in serious injury.
- Before moving auger, check for overhead obstructions and/or electrical wires. Electrocutation can occur without direct contact.
- Disconnect PTO driveline from tractor before moving auger or tractor, and secure driveline in transport saddle (where applicable).
- Raise intake feed hopper into transport position and lock hopper lift winch before transporting or moving auger. Intake feed side of hopper must face main auger when in transport position.
- Do not operate auger with intake hopper in transport position. This will cause damage to the u-joint.

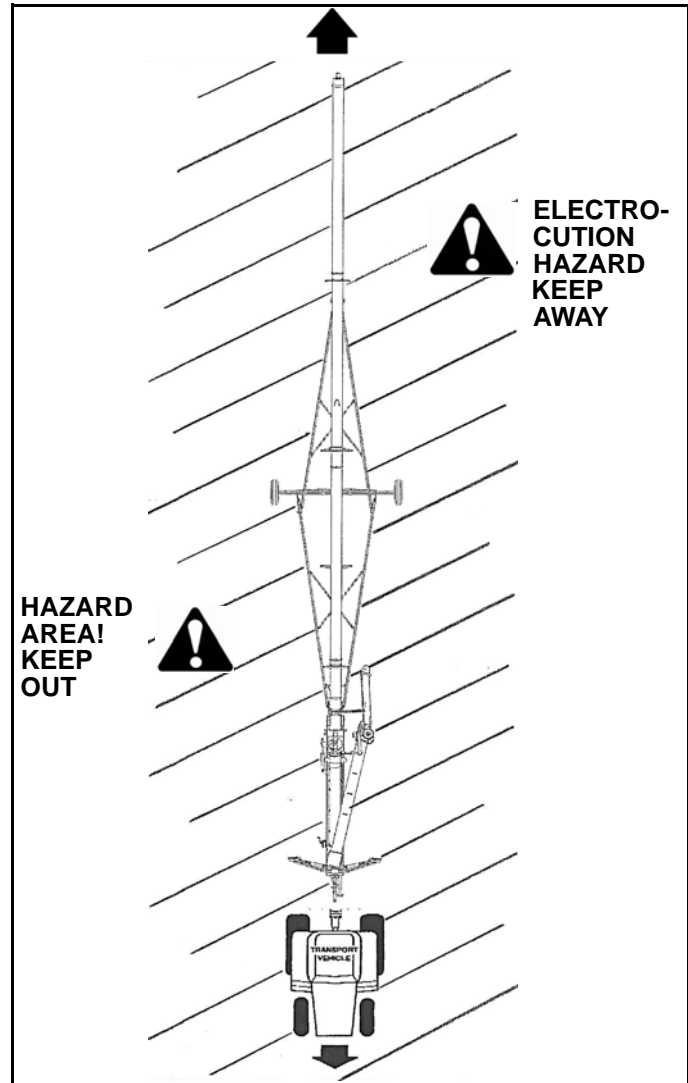

- Not intended for transport on public roads. If auger must be moved, check local length and width regulations. Be careful when turning corners. Watch for low overhead objects. Retract axles before transporting unit.

**Important:** *The Flex Auger exceeds hitch weight and/or towing capacity for some trucks and must be towed with appropriate equipment. A tractor is recommended. Refer to the Specifications Section in the Appendix for details on the weight of this machine. Check with your local dealer if you are unsure.*

## 2.7. MAINTENANCE SAFETY

---

- Shut down and lock out all power before attempting maintenance of any kind. **If applicable**, disconnect PTO driveline from tractor or hydraulic hoses on units with hydraulic drive hoppers.
- After maintenance is complete, replace and secure all safety guards and safety devices, and if applicable, service doors and cleanout covers.
- Support auger tube before attempting maintenance on the undercarriage assembly. Auger should be in full down position for maintenance.
- Use only genuine Westfield replacement parts or equivalent. Replacement parts such as intake guards, pulley guards, PTO driveline shields, winches, and lift cables must meet ASABE standards or serious injury may result. Use of unauthorized parts will void warranty. If in doubt, contact Westfield or your Westfield dealer.
- Do not modify any auger components without authorization from Westfield. Modification can be dangerous and result in serious injuries.

## 2.8. SAFETY DECALS

---

- Keep safety decals clean and legible at all times.
- Replace safety decals that are missing or have become illegible. See decal location figures that follow.
- Replaced parts must display the same decal(s) as the original part.
- Safety decals are available from your distributor, dealer, or factory.

### 2.8.1. DECAL INSTALLATION

---

1. Decal area must be clean and dry, with a temperature above 50°F (10°C).
2. Decide on the exact position before you remove the backing paper.
3. Align the decal over the specified area and carefully press the small portion with the exposed sticky backing in place.
4. Slowly peel back the remaining paper and carefully smooth the remaining portion of the decal in place.
5. Small air pockets can be pierced with a pin and smoothed out using the sign backing paper.

## 2.8.2. SAFETY DECAL LOCATIONS

Replicas of the safety decals that are attached to the equipment are shown in the figure(s) that follow. Proper safety procedures require that you familiarize yourself with the various safety decals and the areas or particular functions that the decals apply to, as well as the safety precautions that must be taken to avoid serious injury, death, or damage.

*\* Westfield reserves the right to update safety decals without notice. Safety decals may not be exactly as shown.*

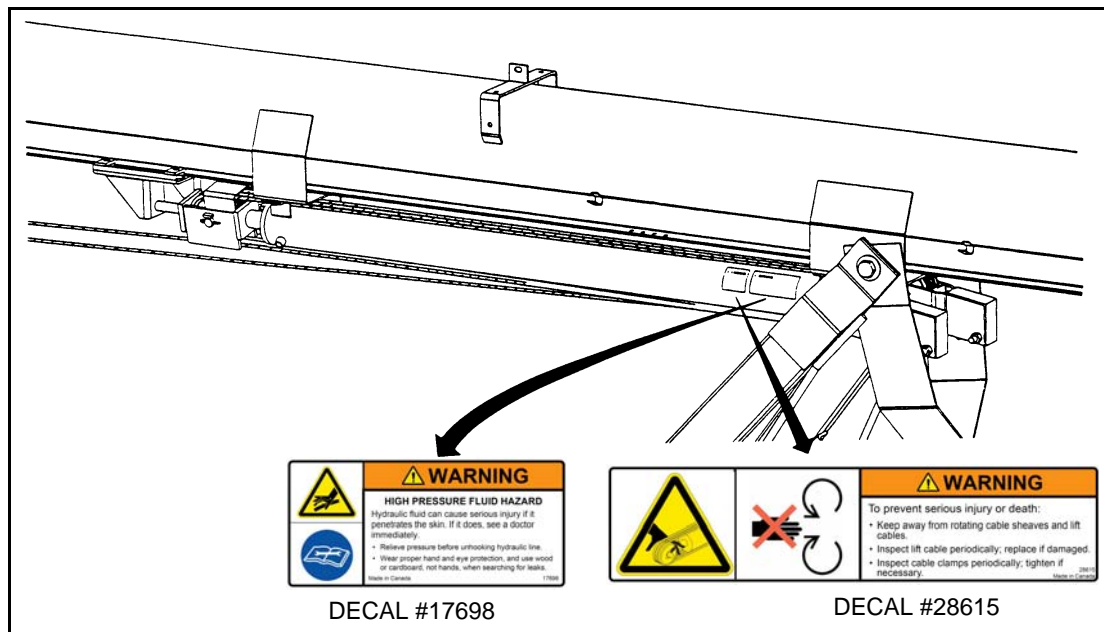

Figure 2.2 SA Flex 111'

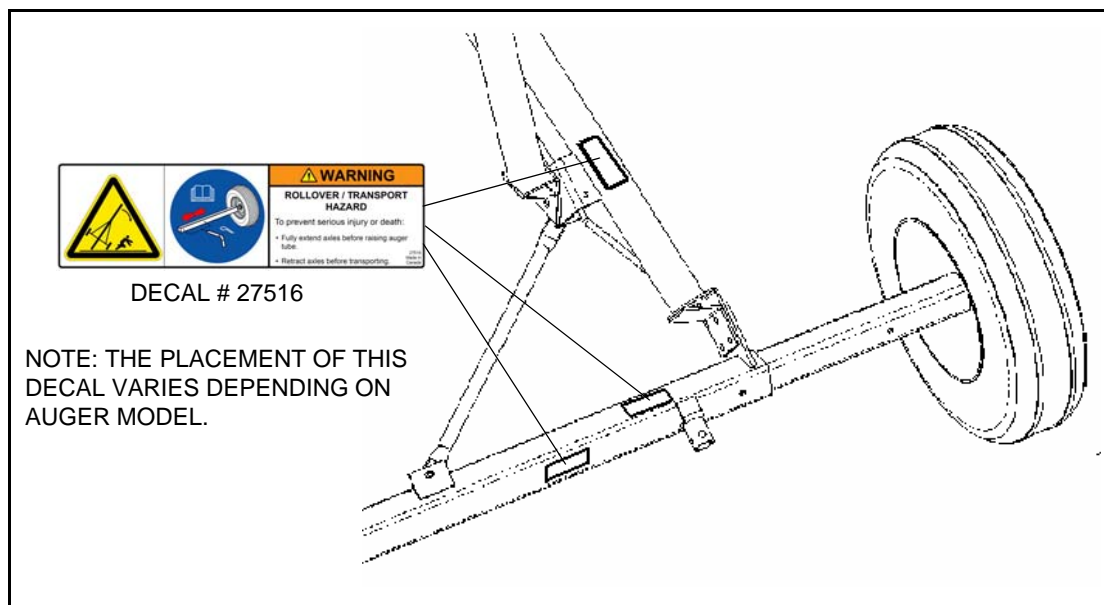

Figure 2.3

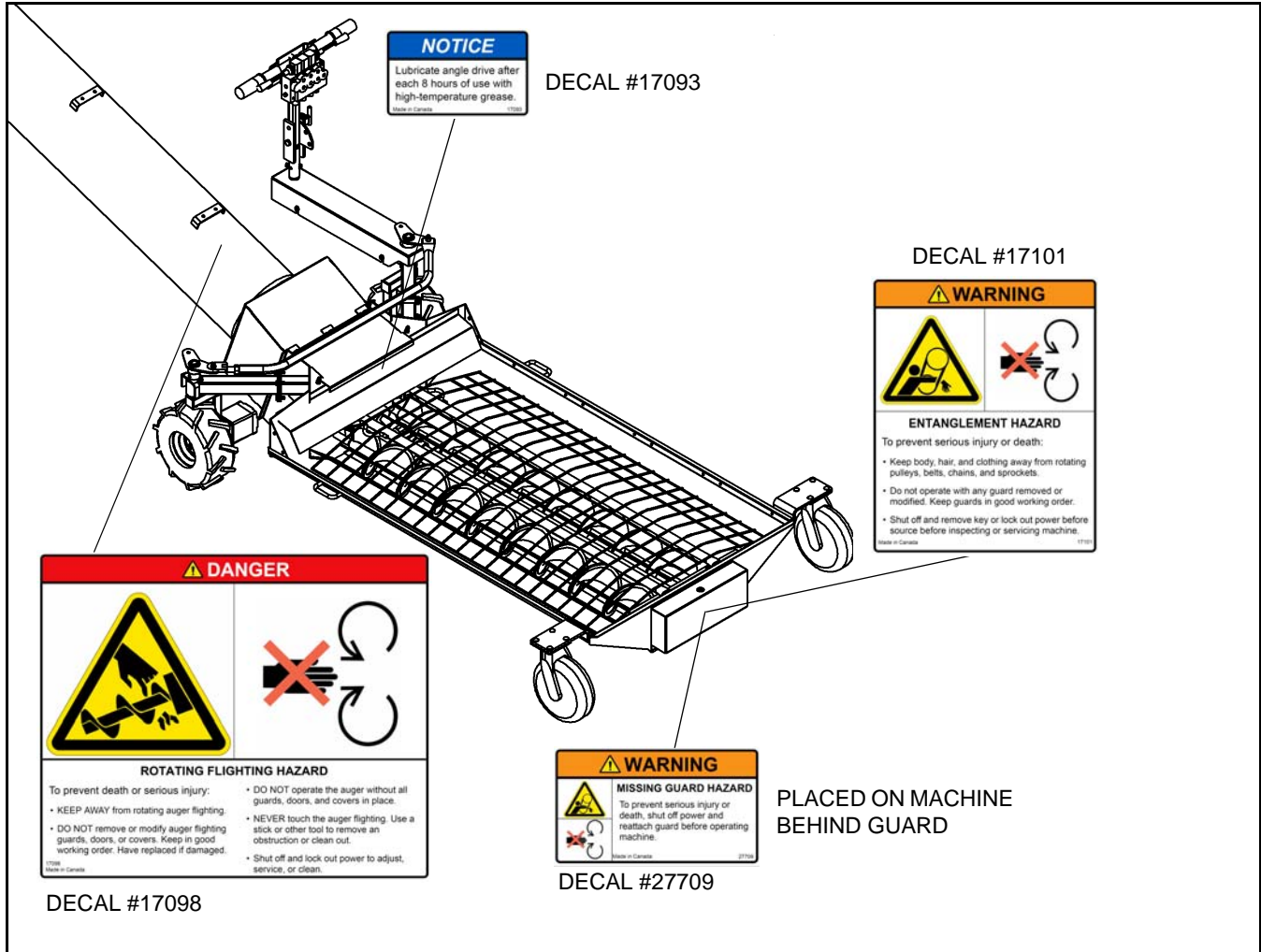

Figure 2.4

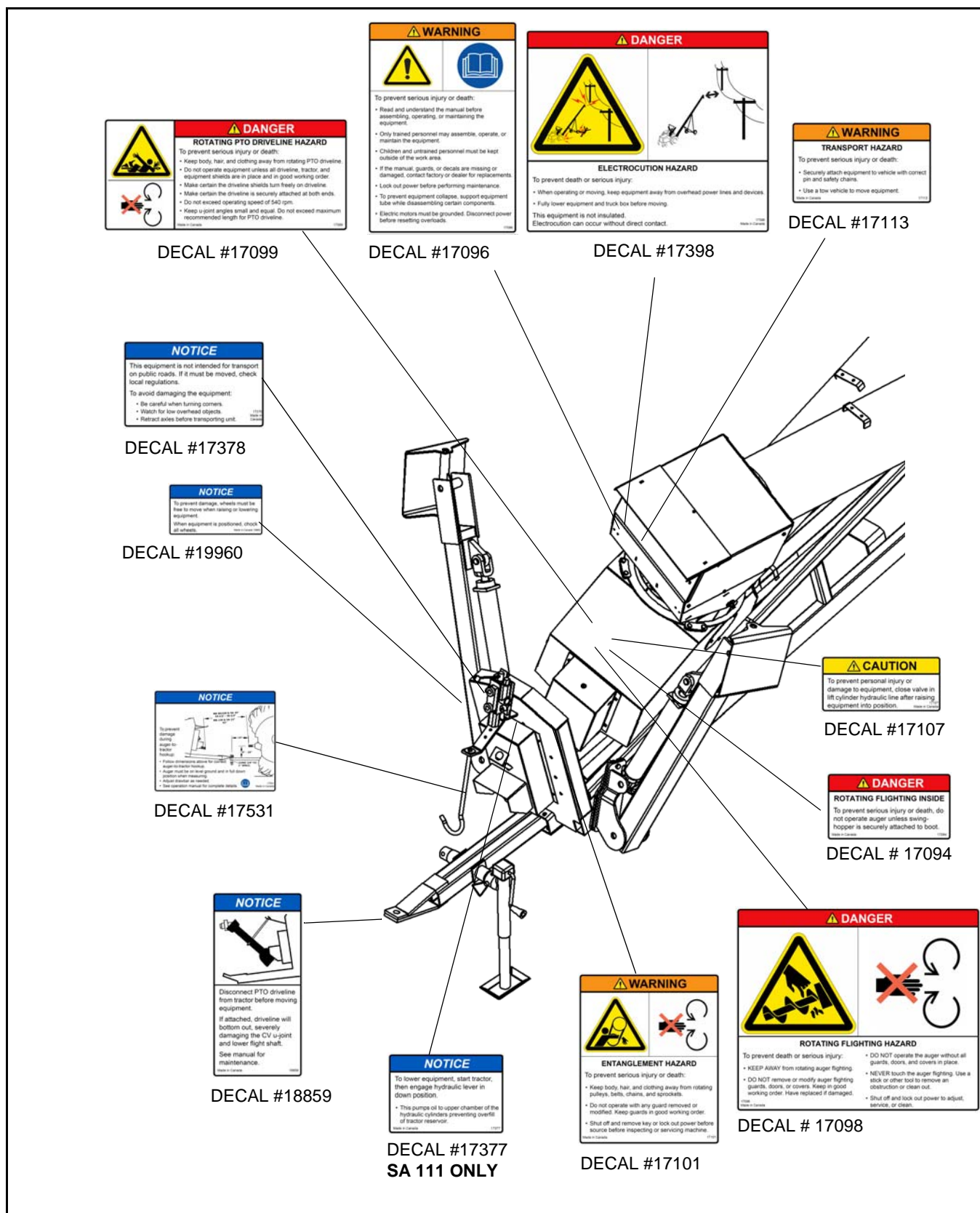

Figure 2.5

**Important:** Please review the decals shown. If your auger does not have these decals, they are available upon request. Please specify which decals you need.





**WARNING**

**HIGH PRESSURE FLUID HAZARD**  
Hydraulic fluid can cause serious injury if it penetrates the skin. If it does, see a doctor immediately.

- Relieve pressure before unhooking hydraulic line.
- Wear proper hand and eye protection, and use wood or cardboard, not hands, when searching for leaks.

Made in Canada 17698

DECAL # 17698



**WARNING**

**MISSING GUARD HAZARD**  
To prevent serious injury or death, shut off power and reattach guard before operating machine.

Made in Canada 27709

DECAL # 27709

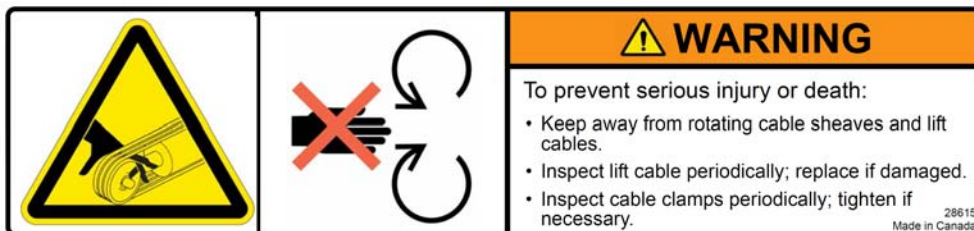

**WARNING**

To prevent serious injury or death:

- Keep away from rotating cable sheaves and lift cables.
- Inspect lift cable periodically; replace if damaged.
- Inspect cable clamps periodically; tighten if necessary.

Made in Canada 28615

DECAL # 28615



**NOTICE**

Lubricate angle drive after each 8 hours of use with high-temperature grease.

Made in Canada 17093

DECAL # 17093

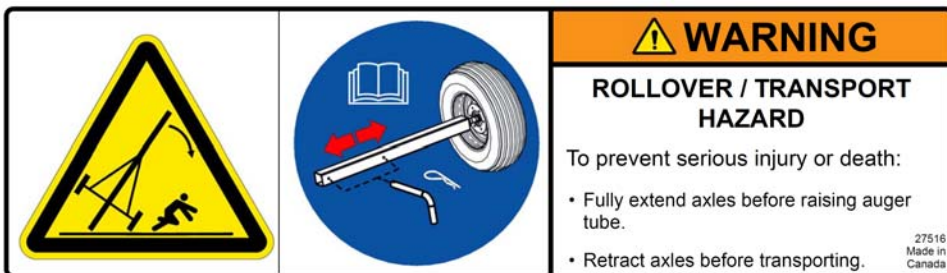

**WARNING**

**ROLLOVER / TRANSPORT HAZARD**

To prevent serious injury or death:

- Fully extend axles before raising auger tube.
- Retract axles before transporting.

Made in Canada 27516

DECAL # 27516

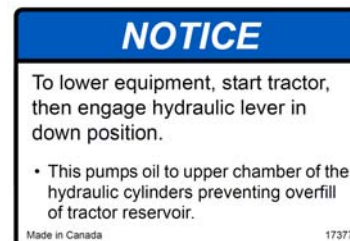

**NOTICE**

To lower equipment, start tractor, then engage hydraulic lever in down position.

- This pumps oil to upper chamber of the hydraulic cylinders preventing overflow of tractor reservoir.

Made in Canada 17377

DECAL # 17377  
SA 111 ONLY



**WARNING**

**ENTANGLEMENT HAZARD**

To prevent serious injury or death:

- Keep body, hair, and clothing away from rotating pulleys, belts, chains, and sprockets.
- Do not operate with any guard removed or modified. Keep guards in good working order.
- Shut off and remove key or lock out power before source before inspecting or servicing machine.

Made in Canada 17101

DECAL # 17101

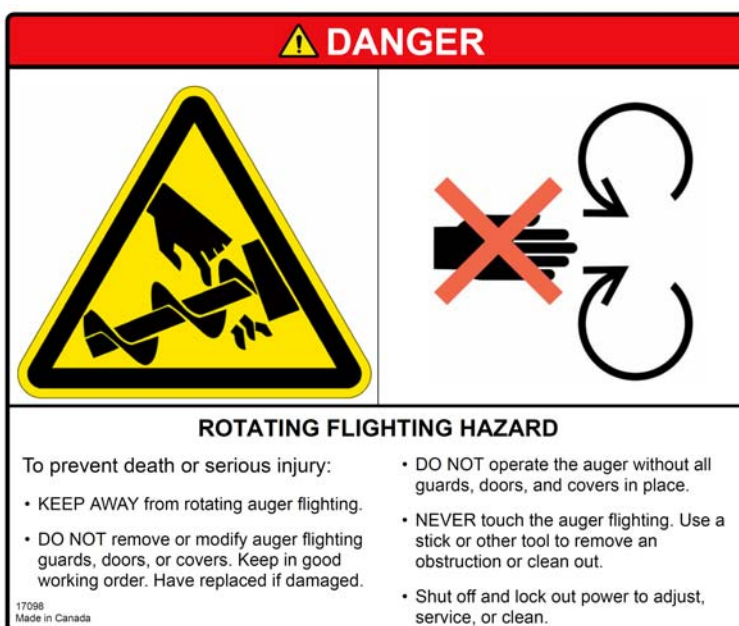

**DANGER**

**ROTATING FLIGHTING HAZARD**

To prevent death or serious injury:

- KEEP AWAY from rotating auger flighting.
- DO NOT remove or modify auger flighting guards, doors, or covers. Keep in good working order. Have replaced if damaged.
- DO NOT operate the auger without all guards, doors, and covers in place.
- NEVER touch the auger flighting. Use a stick or other tool to remove an obstruction or clean out.
- Shut off and lock out power to adjust, service, or clean.

Made in Canada 17098

DECAL # 17098

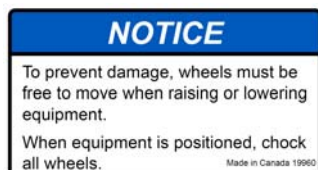

**NOTICE**

To prevent damage, wheels must be free to move when raising or lowering equipment.

When equipment is positioned, chock all wheels.

Made in Canada 19960

DECAL # 19960

**⚠ DANGER**



**ELECTROCUTION HAZARD**

To prevent death or serious injury:

- When operating or moving, keep equipment away from overhead power lines and devices.
- Fully lower equipment and truck box before moving.

This equipment is not insulated.  
Electrocution can occur without direct contact.

17398  
Made in Canada

DECAL # 17398

**⚠ WARNING**



To prevent serious injury or death:

- Read and understand the manual before assembling, operating, or maintaining the equipment.
- Only trained personnel may assemble, operate, or maintain the equipment.
- Children and untrained personnel must be kept outside of the work area.
- If the manual, guards, or decals are missing or damaged, contact factory or dealer for replacements.
- Lock out power before performing maintenance.
- To prevent equipment collapse, support equipment tube while disassembling certain components.
- Electric motors must be grounded. Disconnect power before resetting overloads.

17096

DECAL # 17096

**⚠ DANGER**

**ROTATING PTO DRIVELINE HAZARD**



To prevent serious injury or death:

- Keep body, hair, and clothing away from rotating PTO driveline.
- Do not operate equipment unless all driveline, tractor, and equipment shields are in place and in good working order.
- Make certain the driveline shields turn freely on driveline.
- Make certain the driveline is securely attached at both ends.
- Do not exceed operating speed of 540 rpm.
- Keep u-joint angles small and equal. Do not exceed maximum recommended length for PTO driveline.

Made in Canada 17099

DECAL # 17099

**⚠ WARNING**

**TRANSPORT HAZARD**

To prevent serious injury or death:

- Securely attach equipment to vehicle with correct pin and safety chains.
- Use a tow vehicle to move equipment.

Made in Canada 17113

DECAL # 17113

**NOTICE**



Disconnect PTO driveline from tractor before moving equipment.

If attached, driveline will bottom out, severely damaging the CV u-joint and lower flight shaft.

See manual for maintenance.

Made in Canada 18859

DECAL # 18859

**NOTICE**

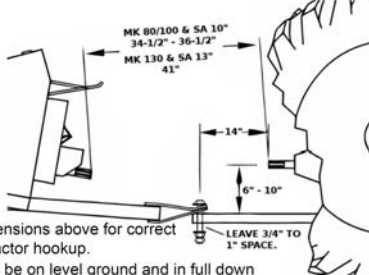

To prevent damage during auger-to-tractor hookup:

- Follow dimensions above for correct auger-to-tractor hookup.
- Auger must be on level ground and in full down position when measuring.
- Adjust drawbar as needed.
- See operation manual for complete details.

17531  
Made in Canada

DECAL # 17531

**⚠ CAUTION**

To prevent personal injury or damage to equipment, close valve in lift cylinder hydraulic line after raising equipment into position.

17107  
Made in Canada

DECAL # 17107

**NOTICE**

This equipment is not intended for transport on public roads. If it must be moved, check local regulations.

To avoid damaging the equipment:

- Be careful when turning corners.
- Watch for low overhead objects.
- Retract axles before transporting unit.

17378  
Made in Canada

DECAL # 17378

**⚠ DANGER**

**ROTATING FLIGHTING INSIDE**

To prevent serious injury or death, do not operate auger unless swing-hopper is securely attached to boot.

Made in Canada 17094

DECAL # 17094

# 3. Assembly

**WARNING** Before continuing, ensure you have read and understand the relevant information in the safety section. Safety information is provided to help prevent serious injury, death, or property damage.

Before beginning assembly, familiarize yourself with all the sub-assemblies and hardware for the auger. Have all parts on hand and arrange them for easy access. Carry out assembly in a large, open area with a level surface.

**Important:** Always have 2 or more people assembling the equipment. Because of the weight, do not attempt assembly alone.

➔ Augers are available in various combinations. In most cases, the following instructions will apply to all augers. Where the assembly information varies, additional instructions will be included, indicated by an arrow.

Before assembling, please check with the customer if they prefer the swing auger on the right or left side of the auger.

## 3.1. TUBES & FLIGHTING

**Note:** When assembling more than 2 sections, start from spout end and work towards hopper.

➔ 1. Position tube sections. Align tube sections on a flat surface or on a series of benches. See Figure 3.24 for the 71', 81' and 91' and Figure 3.26 for the 91' and 111'.

WARNING	
	After positioning tube sections, block them to prevent rolling or dropping. Damage to equipment or personal injury will result.

- The 71' has 3 tubes; from spout: 240" (6.10 m), 240" (6.10 m), and 208" (5.28 m) long.
  - The 81' has 4 tubes; from spout: 240" (6.10 m), 240" (6.10 m), 240" (6.10 m), and 88" (2.24 m) long.
  - The 91' has 4 tubes; from spout: 240" (6.10 m), 240" (6.10 m), 240" (6.10 m), and 208" (5.28 m) long.
  - The 111' has 5 tubes; from spout: 240" (6.10 m), 240" (6.10 m), 240" (6.10 m), 240" (6.10 m), and 208" (5.28 m) long.
2. To attach lift cylinders, rotate appropriate tube so track is facing upward as shown in Figure 3.1.
- a. Attach the lift cylinders to the attach brackets as shown in Figure 3.1 using 7/16" x1-1/4" bolts and locknuts.
    - outside tabs—use regular bolts

- ➔ • **Only for 71'/81'**: inside tabs – use regular bolts.
- ➔ • **Only for 91'/111'**: inside tabs – use bolts with extension rods welded to head.
- ➔ b. **Only for 81'/91'/111'**: Slide the lift ram guide onto track on tube, then insert ram ends into brackets on guide (Figure 3.1). Secure with two roll pins.
- c. Return this tube section to the track down position.

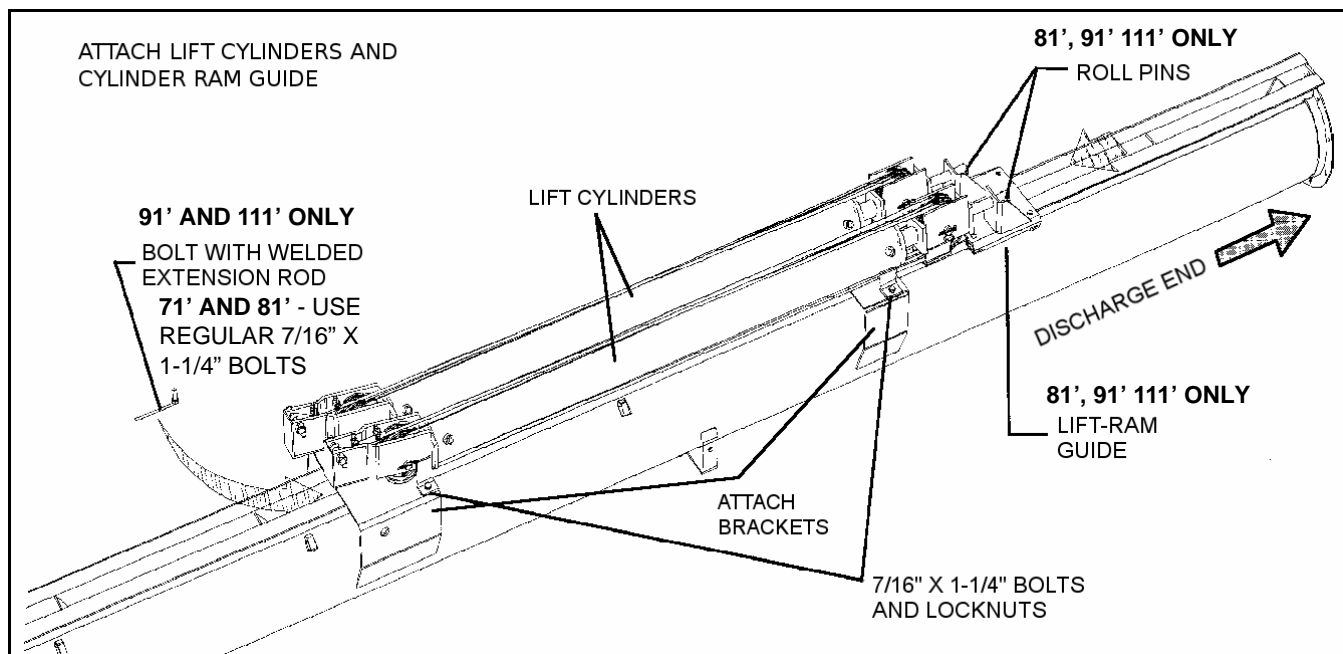

**Figure 3.1**

3. Slide lower flight shaft onto upper flight shaft until flight ends butt together and flighting spiral matches up (Figure 3.2). Secure with hardware in Table 3.1. Repeat, if necessary, for any remaining flight shafts.

**Table 3.1**

Details for fastenings: <sup>a</sup>			
For Flighting	Qty	For Tubes	Qty
5/8" x 4-1/2" GR8 bolts and locknuts	2	7/16" x 1-1/4" GR8 bolts and locknuts	12
<b>Track End (91' and 111' only)</b> 5/8" x 2-3/4" GR8 bolt and locknut	1	1/2" x 1-3/4" GR8 bolts and locknuts (2 top and 2 bottom)	4

a. Quantity listed is per tube connection.

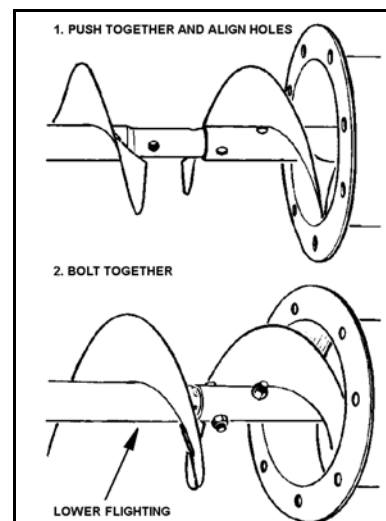
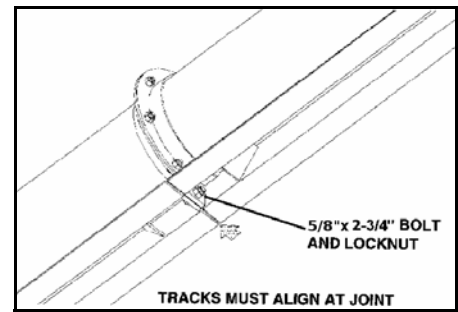

**Figure 3.2**

4. Slide tube sections together and secure. Make sure upper and lower track ends are aligned, and then tighten bolts. Secure with hardware in Table 3.1.

**Important:** Do not connect lower auger tube to mid auger tube at this point! (Figure 3.4).

- ➔ 5. **91' and 111' only:** Bolt the track ends together (Figure 3.3).
- 6. Adjust lower auger tube out until it is flush with the flight shaft end (see Figure 3.4).
- 7. Lift the flex frame up underneath the lower tube and secure on benches.
- 8. Push the flex frame toward the spout to slide the auger flight through the front of the flex frame boot.



**Figure 3.3 91' and 111' only**

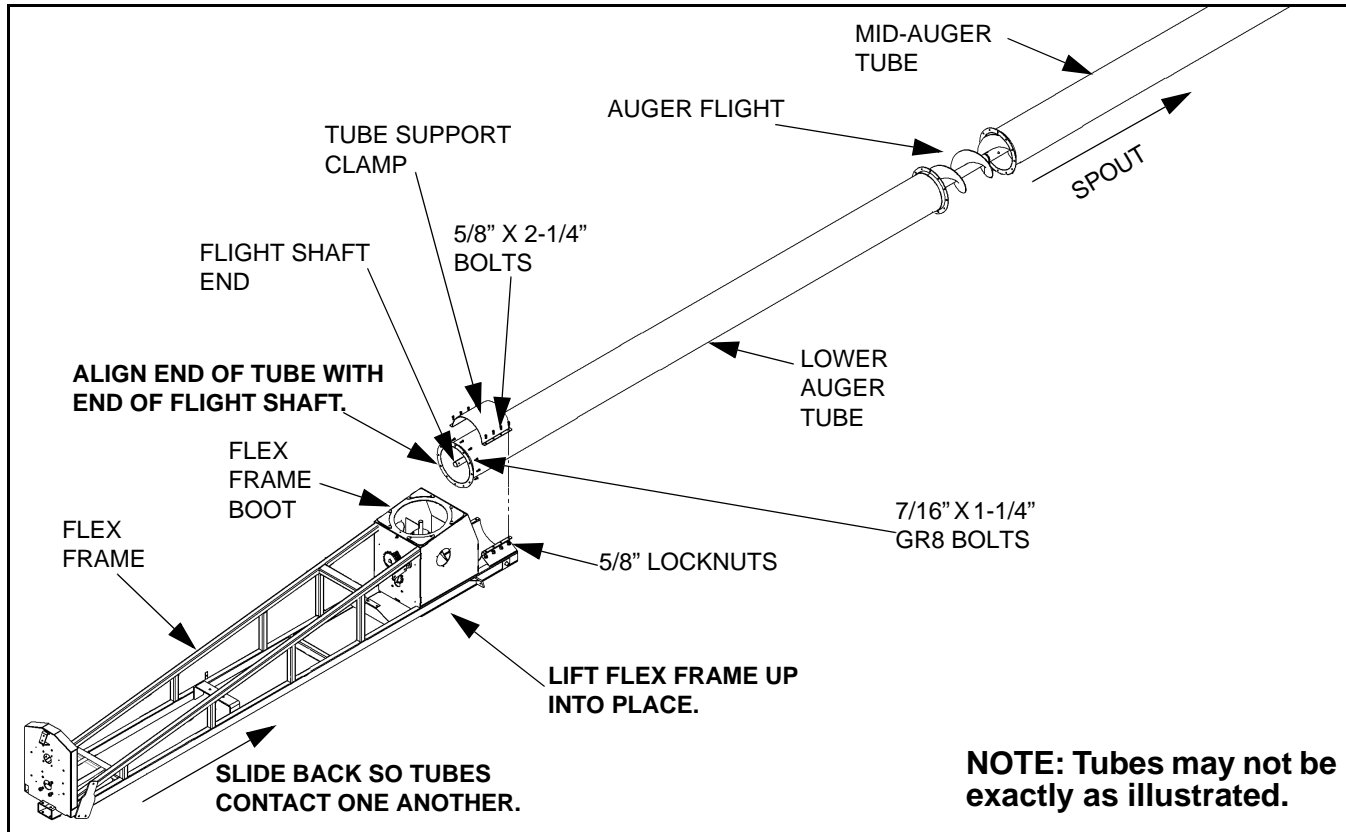

**Figure 3.4**

- 9. Connect flex frame assembly to lower auger tube flange with twelve 7/16" x 1-1/4" GR8 bolts and locknuts.
- 10. Secure tube support clamp to tube with eight 5/8" x 2-1/4" GR8 bolts and locknuts.

**Important:** *Steps 11. to 20. must be completed in the order listed to prevent premature failure of the lower bearing. Refer to Figure 3.6.*

- 11. Slide lower bearing onto flight stub and secure boot loosely with four 5/8" x 1-3/4" bolts and 5/8" locknuts.
- 12. Loosen setscrew on lock collar and slide it onto the lower flight. Leave lock collar loose for now.

**Important:** *Grease zerk should be located on left side of bearing.*

- 13. Seat flight shaft shoulder against washer and lower bearing, see Figure 3.6. Do not tighten bearing bolts until after step 19.

14. Now, slide the middle and lower tube sections together and secure with twelve 7/16" x 1-1/4" bolts and locknuts.

- ➔ 15. **81' Only:** Attach track clamp to tube with three 1/2" locknuts.

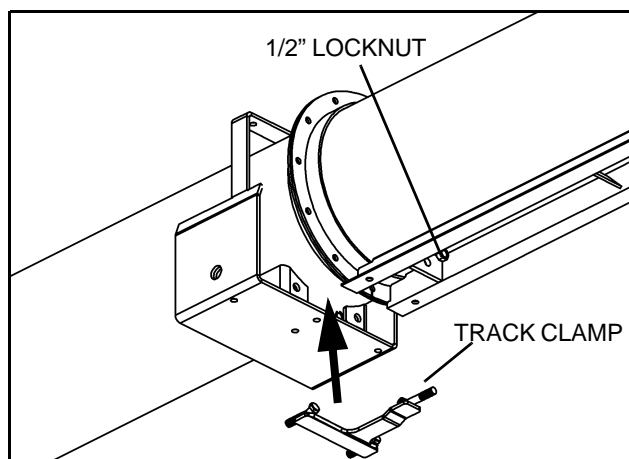

Figure 3.5 1381 MK Flex Track Clamp

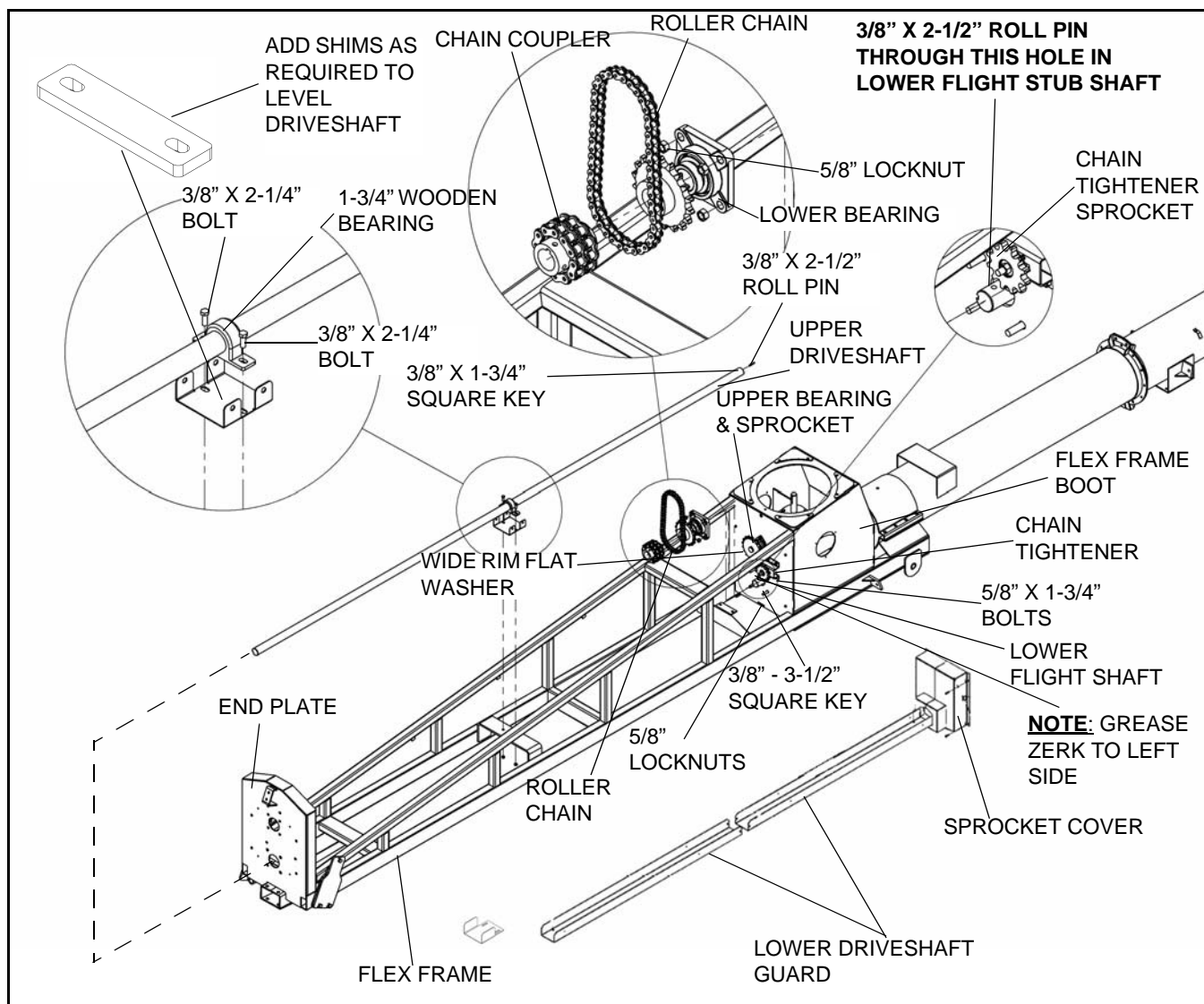
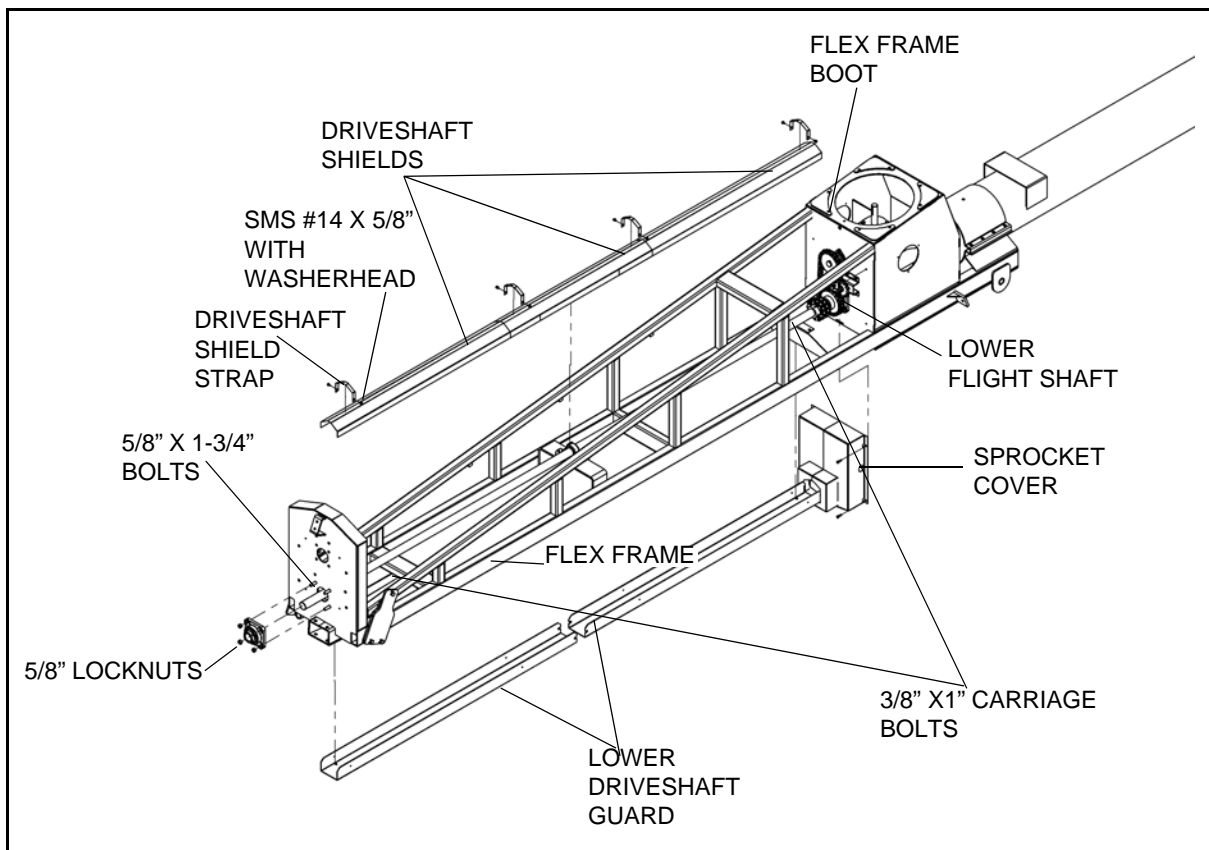

Figure 3.6

16. Install 3/8" x 3-1/2" square key and slide lower sprocket onto lower flight shaft.
17. Align upper sprocket with lower sprocket and chain tensioner sprocket using straight edge, then tighten setscrews and locking collar on upper bearing.
18. Loosen chain tightener sprocket and install roller chain on upper and lower sprockets. Secure with connecting link and clip.
19. Oil chain lightly and tension.
20. Tighten 5/8" locknuts on the lower bearing. Tighten collar on lower bearing and tighten setscrew.
21. Install two sections of lower driveshaft guard as well as the driveshaft guard extension with 3/8" x 1" carriage bolts and 3/8" x 1" bolts and flange nuts. Tighten the guard extension and lower half of the guard. Leave the top half hand tight until the two piece chain guard is in place. Figure 3.6.

**Note:** *The driveshaft ends are different. Make sure the end with the hole is at the lower end of the flex frame.*

22. Place bracket under middle of driveline with spacer and use shims provided to level.
23. To install chain coupler (shipped assembled):
  - a. On the two half-sprockets: check to make sure the keyways are NOT lined up. If they are, disassemble the chain coupler and offset the keyways, then reassemble.
  - b. Slide the chain coupler onto the lower flight stub shaft, and attach it using 3/8" x 2-1/2" roll pin.
  - c. Install the 3/8" x 1-3/4" square key onto the solid driveshaft, and slide the driveshaft into the opposite end of the chain coupler. Slide it in 1-3/4", until the end of the driveshaft is flush with the end of the sprocket.
  - d. Secure both sides of the chain coupler using the setscrews; tighten securely.
  - e. Disassemble the 1-3/4" wooden bearing (as supplied). Re-assemble the bearing around the solid driveshaft, and attach it to the frame using two 3/8" x 2-1/4" bolts and locknuts provided. Use shims as necessary; wood bearing is there for support only, DO NOT force shims into place. Once satisfied with driveline alignment, tighten bolts and locknuts securely.



**Figure 3.7**

24. Secure the driveshaft to the front plate of the flex frame with a 1-3/4" bearing and flange and four 5/8" x 1-3/4" bolts and locknuts. Secure lower driveshaft with locking collar and setscrew.
25. Grease zerk should be located on left side of bearing.
26. Attach sprocket covers to flex frame boot with four 5/16" x 3/4" bolts and locknuts
27. Place two 60" and one 48" driveline guards over shaft and secure to flex frame with driveshaft shield straps and SMS #14 x 5/8" with washerhead.



## 3.2. DISCHARGE SPOUT & THRUST ADJUSTER

- Attach discharge spout with 7/16" x 1-1/4" bolts and lock-nuts.
- The thrust adjuster is designed to transfer some pressure from the lower flight bearing to the upper flight bearing.
  - Remove cover and 5/8" whiz nuts.
  - Loosen the set screw on the lock collar and disengage the lock collar from the bearing to allow free movement of the flight shaft.
- Turn the 1-1/2" nut until it is snug against the bushing, then turn it so that the flight shaft moves an additional 1/4" (0.64 cm).
- Secure the lock collar and tighten the set screw.
- Re-install the cover over the two longer 5/8" bolts. Secure with two 5/8" whiz nuts.

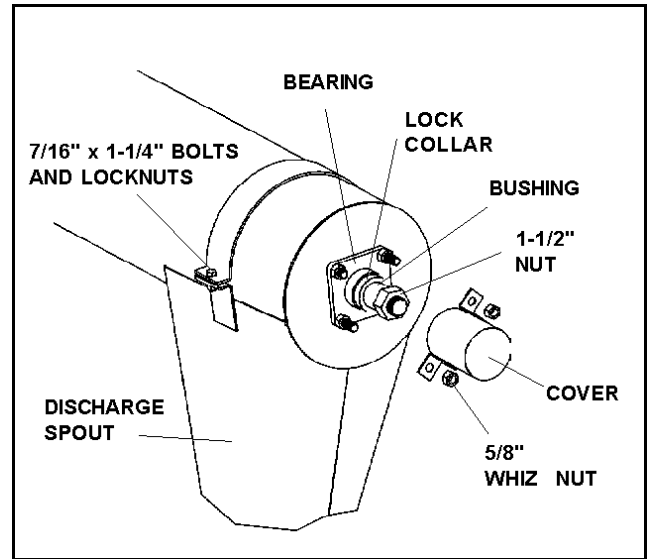

## 3.3. FLEX FRAME COMPONENTS

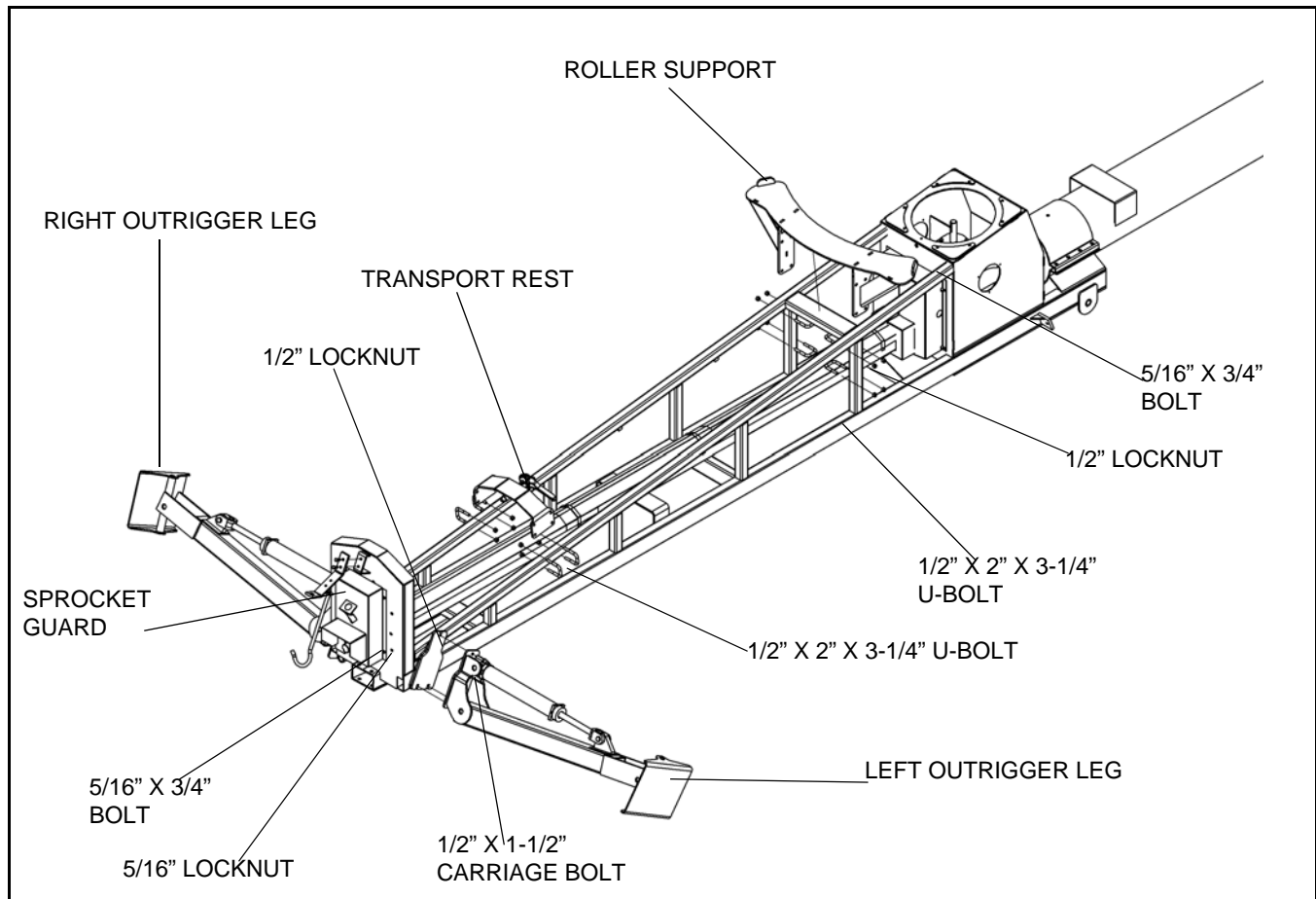

**Figure 3.8**

1. Install outrigger legs. Insert 1/2" x 1-1/2" carriage bolts pointing inward to prevent interference with hydraulic cylinder.

**Important:** *There is a left and a right outrigger leg. Ensure they are installed with ports facing the discharge.*

2. Place roller support inside key stops on flex frame, see Figure 3.8. The four 1/2" x 2" x 3-3/4" u-bolts are attached around the upright tubes, as shown in Figure 3.8. Ensure that these u-bolts are tightened securely.
3. Install sprocket guard on boot with four 5/16" x 3/4" bolts. Ensure that tabs on 2 piece sprocket guard are fit into the slots on either side of the lower guard. Tighten the top half of the lower guard.
4. Attach the transport rest to flex frame with four 1/2" X 2" x 3-1/4 u-bolts and locknuts. Leave flex tube support transfer rest untightened until after the flex tube is installed.

## 3.4. FLEX TUBE ASSEMBLY

Complete assembly in the order listed to prevent premature failure of the lower bearing. Refer to Figure 3.9 to 3.11.

1. Attach boot spinner plates.
  - a. Insert plates between boot spinner and upper flex tube bundle.
  - b. Mount onto the four 7/16" x 1-3/4" bolts welded to the tube.
  - c. Fasten with 7/16" locknuts and 7/16" washers.
  - d. Do not tighten all the way.
  - e. Ensure boot is angled on the same side as swing tube is to be installed.
  - f. Secure with eight 7/16" x 1-1/4" bolts with locknuts and washer.

**Note:** Flex boot can be rotated to the left or the right side of the auger. Figure 3.10 and 3.11 show setup for swing on right side of the auger, as viewed from the intake end facing toward the spout. To install the flex boot on left side, rotate boot to left side

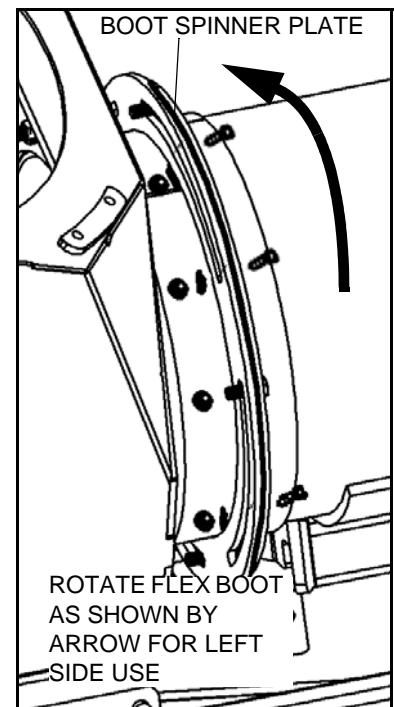
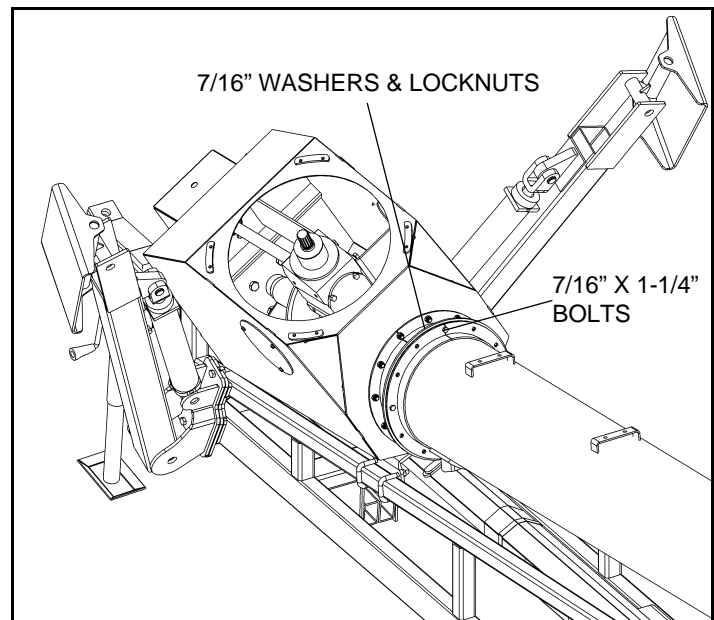

**Figure 3.9**

2. Place 1-3/4" wide rim washer and 1-3/4" bearing and flange on flight shaft with 5/8" x 1-3/4" bolts and locknuts. Do not tighten until Step 5.

**Important:** Grease zerk should be located on left side of bearing.

3. Install square key and slide lower sprocket onto flight shaft.
4. Align lower sprocket with upper sprocket using straight edge, then tighten set screws.
5. Install roller chain on sprockets and adjust tension to about 1/4" (0.64 cm) deflection. Tighten the 4 bolts on lower bearing and secure lock collar. Oil chain lightly.
6. Bolt chain guard on boot with four 5/16" x 3/4" bolts and locknuts.
7. Bolt half band and pivot support together with 7/16" x 1-1/4" bolts and locknuts on flex tube, 24" (61.0 cm) from spout plate. See Figure 3.11.



**Figure 3.10**

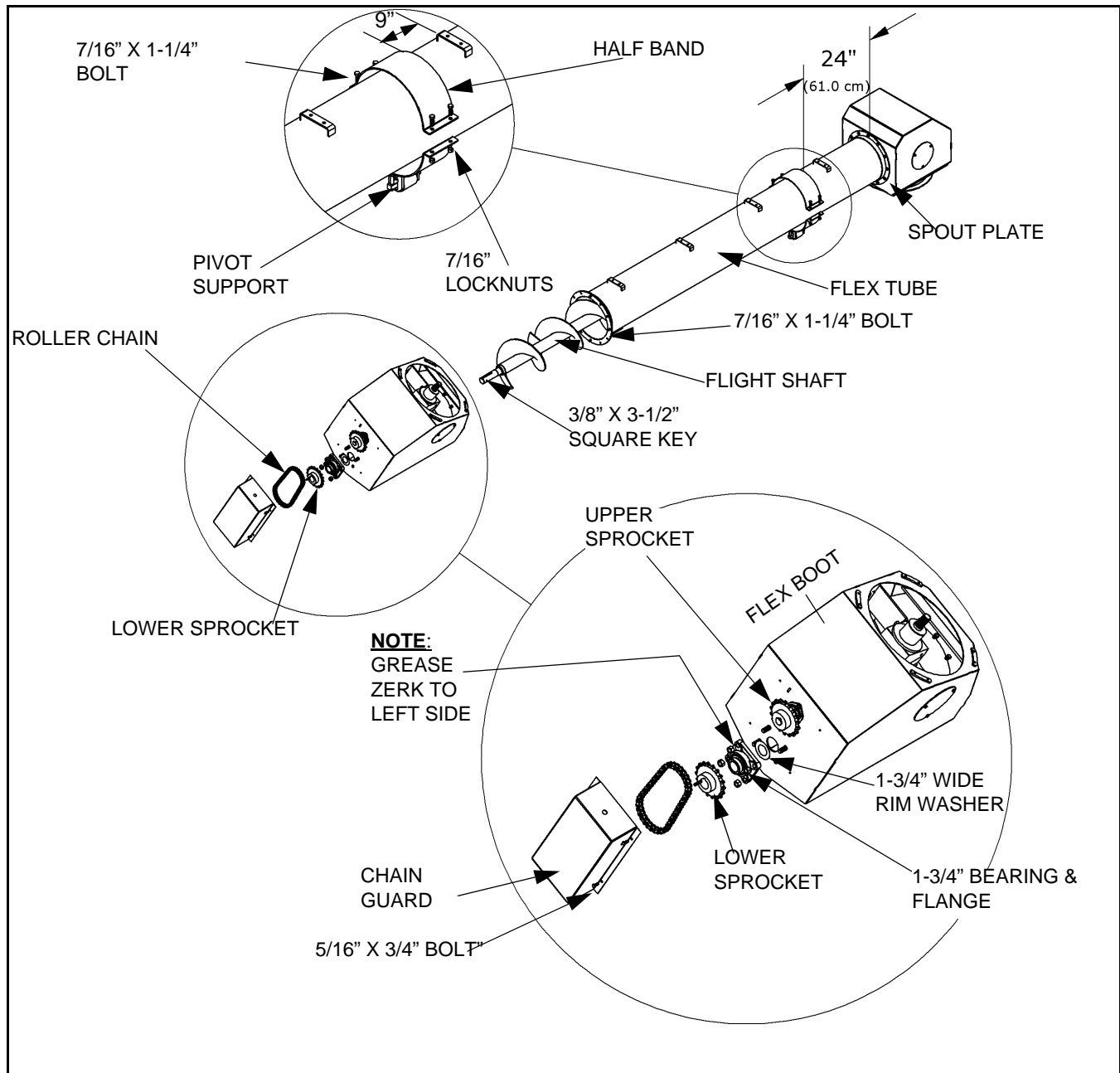

Figure 3.11

## 3.5. CONNECTING FLEX TUBE TO FLEX FRAME

1. Place wide rim flat washer and 1/4" x 1-1/4" key on the gearbox shaft.
2. Place upper flex tube on flex frame as shown aligning u-joint in flex tube spout on the gearbox in the boot.
3. Place 6 galvanized spacers (4 in front, 2 in back) and 2 pivot plates on flex frame boot. Secure flex spout on flex frame with 7/16" x 1-3/4" bolts and locknuts.
  - Upper plate has grease nipples on it; the lower plate does not.
  - Grease nipples are in bolt bag and need to be installed.

**Important:** *Pivot plates must be installed as illustrated.*

4. Install 2-1/2" x 16" cylinder to flex spout and cylinder bracket as shown in Figure 3.12. Use two 1/4" x 1-3/4" cotter pins to assemble cylinder pin and use snap rings provided to assemble clevis pin.

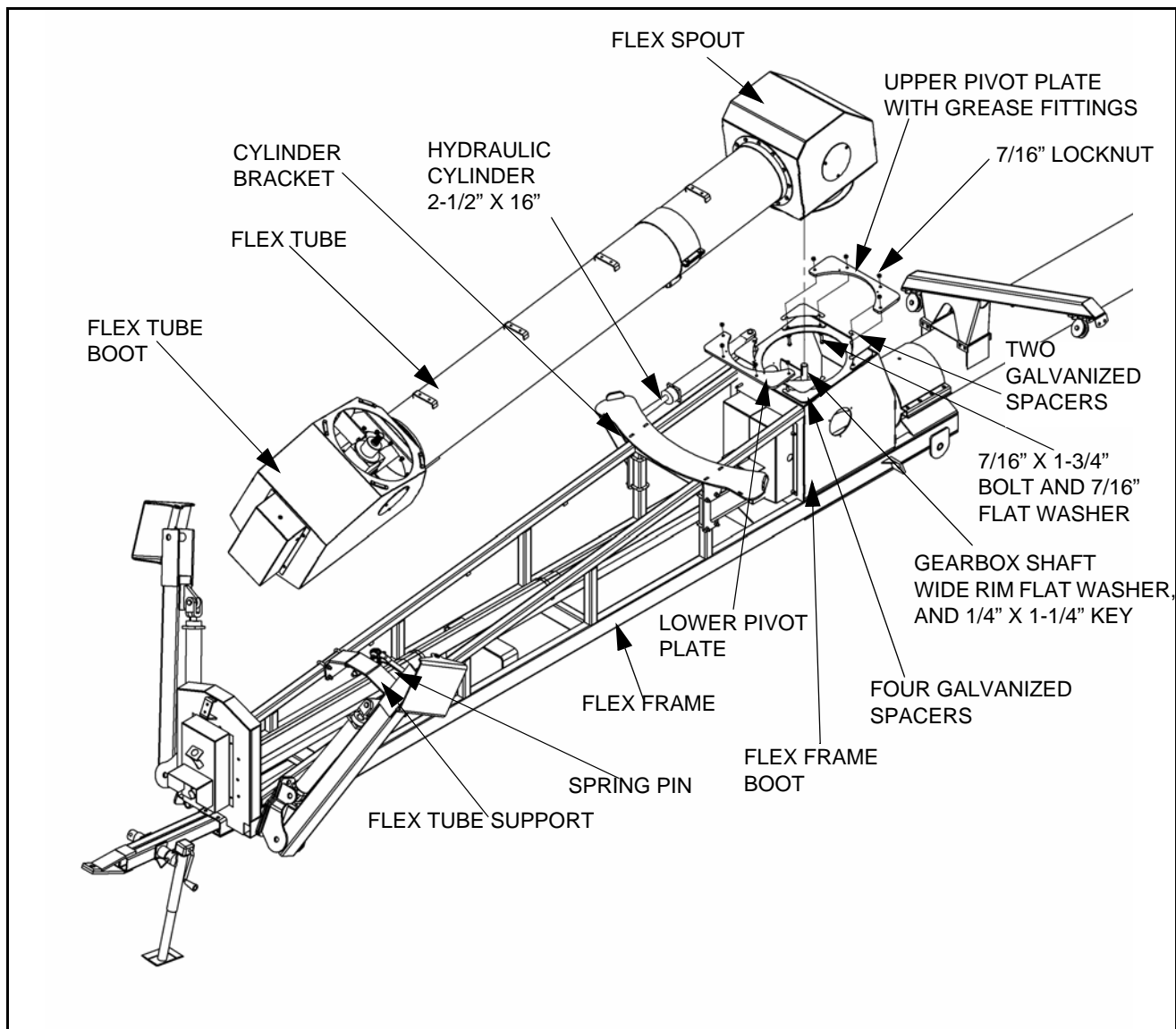

**Figure 3.12**

- Adjust the position of the flex tube support, so that the lock pin sticks through the transport latch approximately 1/16" (1.6 mm). Tighten u-bolts and locknuts and secure. See Figure 3.13.

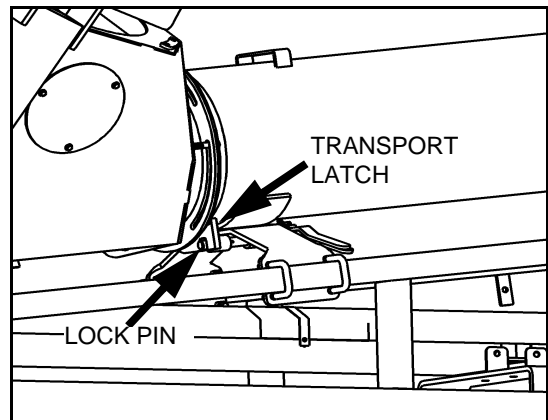

Figure 3.13

- Use a hoist to lift the lower end of flex tube slightly and adjust the position of the pivot roller with the 1/2" x 2-1/2" adjustment bolts to carry the weight of the flex tube. See Figure 3.14.

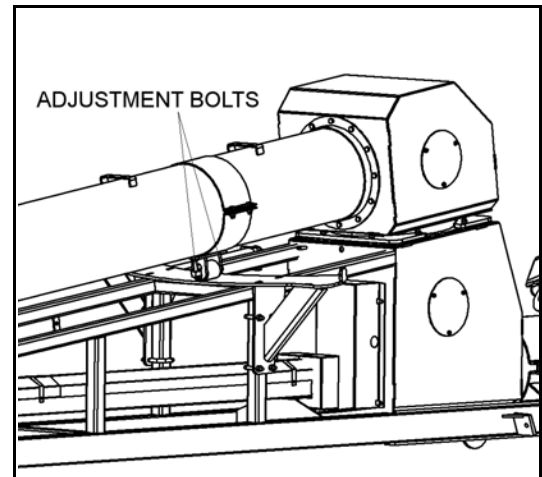

Figure 3.14

### NOTICE

Failure to lift the flex tube when adjusting the pivot roller can result in damage to the roller and/or flex tube.

## 3.6. TRACK SHOE, TRACKSTOP, & LIFT-ASSIST ARM (71'–81')

Auger	Track Stop
MK Flex 71'	2nd set of holes from top
MK Flex 81'	set of 8 holes grouped together

- ➔ 1. **71'**: Slide the double roller track shoe onto track with cable attach-rod towards auger intake (Figure 3.15). Attach the angle trackstop as shown in Figure 3.16 using four 7/16" x 1-1/4" bolts and locknuts.
- ➔ 2. **81'**: Slide the four roller track shoe onto track (Figure 3.17). Attach angle track stop with eight 7/16" x 1-1/4" GR8 bolts and locknuts (Figure 3.18).

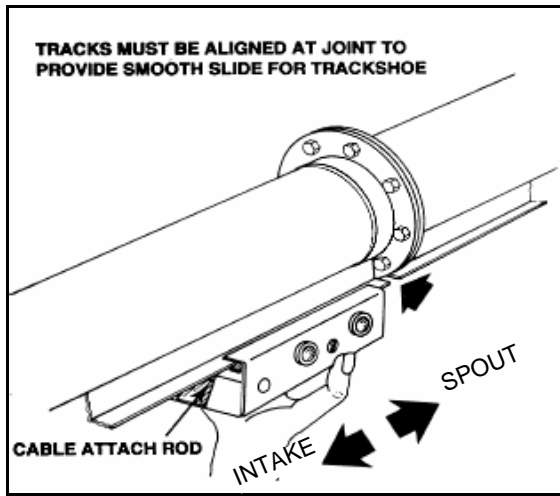

Figure 3.15 71'

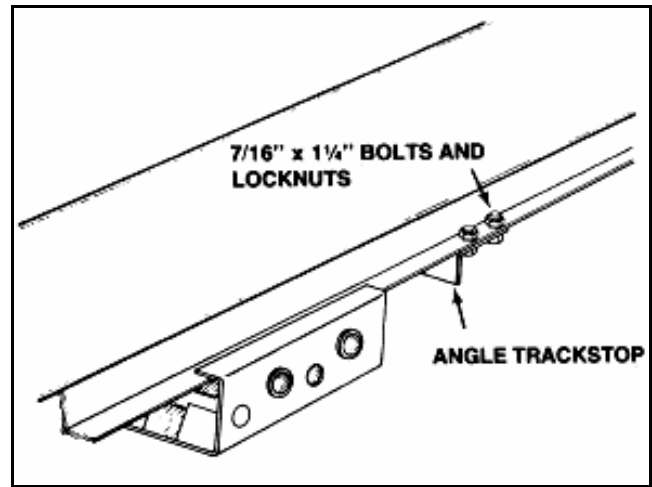

Figure 3.16 71'

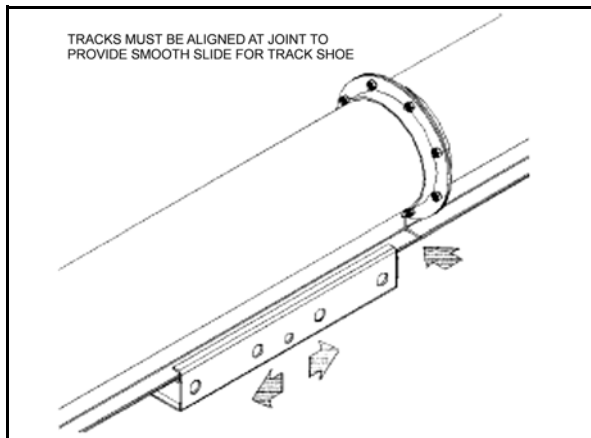

Figure 3.17 81'

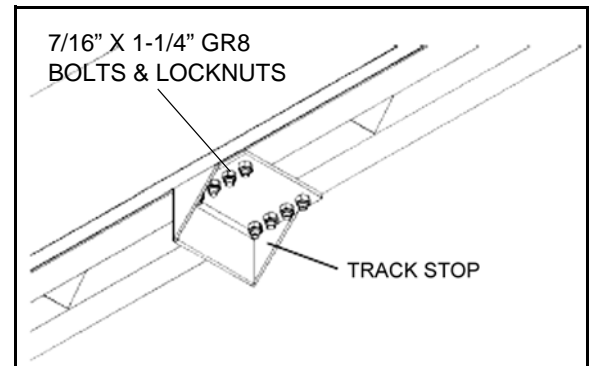

Figure 3.18 81'

3. Slide track shoe along full length of track to make sure there is no binding and that track ends are properly aligned.



4. **81'**: Attach the lift-assist arm to the center hole on the track shoe with an 11/16" short spacer and 1" flat washer on each side and a 1" x 10" bolt and locknut. **Tighten securely** (Figure 3.19).

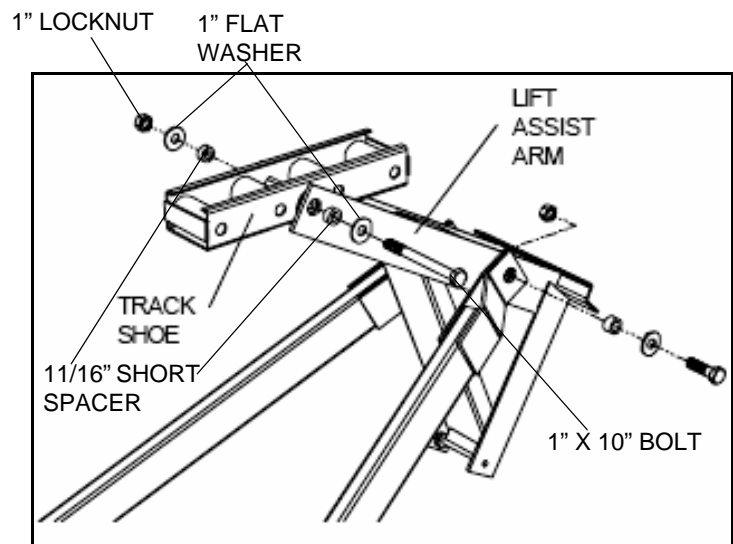

Figure 3.19 81'

## 3.7. TRACK SHOE, TRACKSTOP, & LIFT-ASSIST ARM (91'-111')

1. Slide the four-roller track shoe onto the track on the tube. See Figure 3.21.
2. Attach the trackstop to the upper end of the track on the auger tube with eight 7/16" x 1-1/4" GR8 bolts and locknuts. See Figure 3.20.

➔ The 91' auger trackstop should be 132" from intake end of the upper middle tube, while the 111' trackstop should be 59-1/2" from intake end of the upper middle tube (Figure 3.20).

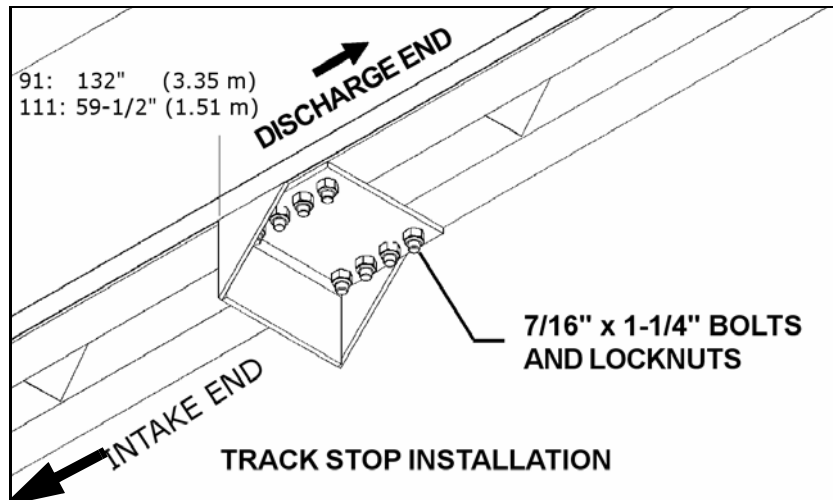

Figure 3.20

3. Slide the track shoe along the full length of track to make sure there is no binding and that track ends are properly aligned. Adjust tube joints if necessary (Figure 3.21).
4. Attach the lift-assist arm to center hole on track shoe with an 11/16" short spacer and 1" flat washer on each side, and a 1" x 10" bolt and locknut (see Figure 3.36 on page 47). Tighten securely.

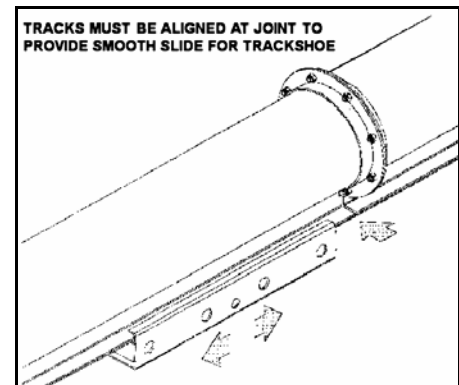

Figure 3.21

## 3.8. ADJUSTABLE TOWBAR

➔ The Flex has an adjustable towbar. The towbar is installed as seen in Figure 3.22.

1. Insert the adjustable towbar into the boot channel. Secure by placing a 3/4" x 6-1/2" long bolt and locknut through the back hole in the boot channel, under the flex frame.
2. Insert a 5/8" x 4-1/2" long bolt and locknut vertically into the hole at the front of the boot so that the towbar comes straight out from the flex frame.
  - This bolt must be inserted from the bottom with the nut on top.

**Important:** *Adjust the towbar if a speed-reducing gearbox is used with the system. In this case, the towbar is extended and pinned on an angle using the vertical bolt. This will line up the PTO with the PTO connection on the gearbox.*



3. Install the PTO cradle bracket on the front plate of the flex frame. Attach bracket with two 7/16" x 1-1/4" bolts and locknuts.

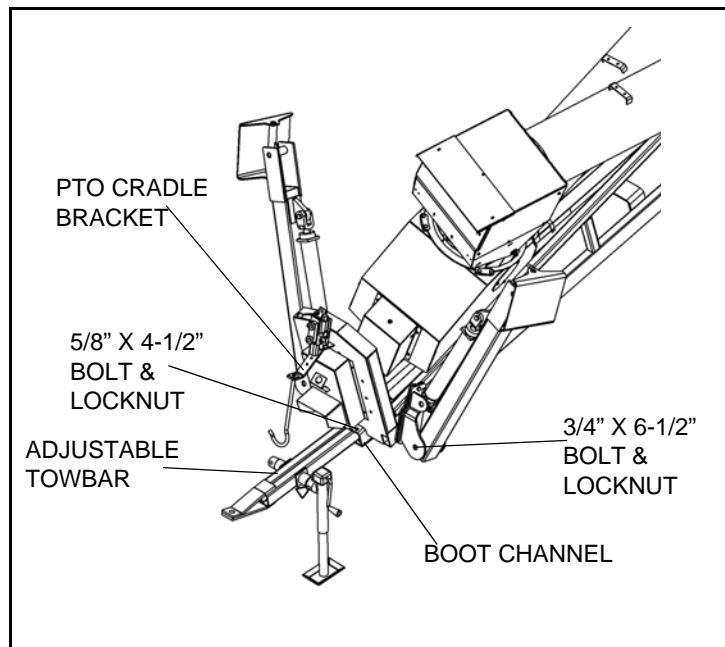

Figure 3.22

## 3.9. TRUSS (71'-81')

See Figure 3.23 and 3.24.

**Note:** *Figure 3.23 is shown only to illustrate components and is not an exact representation of the 71' or 81' Flex Auger. See Figure 3.24 for correct cable location.*

**Note:** *Two 3/8" cable clamps per side of each cable are supplied to secure truss cables to the eyebolts as described below. All other locations require 5/16" cable clamps.*

1. Fasten 2 standard truss support brackets to the correct position on the auger tubes with two 7/16" x 1-1/4" bolts and locknuts for each (Figure 3.24).
2. Fasten a high truss support bracket between the 2 standard truss support brackets with two 7/16" x 1-1/4" bolts and locknuts (Figure 3.23, and 3.24).
3. Attach eyebolt to one end of truss cable with two 3/8" cable clamps. Insert eyebolt into lower truss anchor and thread on nut a short way.
4. Pull truss cable over truss support brackets, around upper truss anchor bracket and back over truss support brackets to lower truss anchor, holding it loosely in place with one 5/16" cable clamp at upper truss anchor on each truss support bracket.

**Important:** *Do not tighten cable clamps at this time.*

5. Place other eyebolt onto lower truss anchor and thread on nut a short way.
6. Insert other end of truss cable through this eyebolt. Pull out all slack and secure with two 3/8" cable clamps.

7. The upper end of all augers should have an upward bow before being placed on the transport undercarriage (auger tube will straighten when fully assembled). Place supports under the discharge end until upward bow is correct.
  - The upward bow should be about 5" (12.7 cm) on the 71' auger, and 6"-7" (15.2 cm - 17.8 cm) on the 81' auger.
8. Tighten eyebolts to take remaining slack out of truss cable and to maintain the appropriate upward bow. After tension is adjusted, tighten cable clamps on truss support brackets and upper truss anchor. Check for proper side alignment.

**Important:** *Once auger is fully assembled, adjust truss cables on all units (because of initial stretching). Cables may also require adjustment for side alignment.*



9. **Lower Truss Support of 81'** (Figure 3.23 and 3.24):
  - a. Fasten short truss anchor to lower auger tube with 7/16" x 1-1/4" bolts and locknuts.
  - b. Fasten high truss support bracket to mount on bottom of center tube with 7/16" x 1-1/4" bolts and locknuts.
  - c. Attach eyebolt to one end of truss cable with two 3/8" cable clamps, then insert eyebolt into short truss anchor and thread on nut a short way.
  - d. Pull truss cable over bottom high truss support bracket, around upper truss anchor bracket and back over high truss support bracket to short truss anchor, holding it loosely in place with one 5/16" cable clamp (on each side) at upper truss anchor and two 5/16" cable clamps at truss support bracket.
  - e. Place other eyebolt into short truss anchor and thread nut on a short way.
  - f. Insert other end of truss cable through this eyebolt. **Pull out all slack** and secure with two 3/8" cable clamps.
  - g. Tighten eyebolt to take remaining slack out of truss cable and adjust tension to keep auger tube straight. Tighten cable clamps on truss support bracket and upper truss anchor.

**Important:** *Once auger is fully assembled, adjust truss cables (because of initial stretching). Cables may also require adjustment for side alignment.*

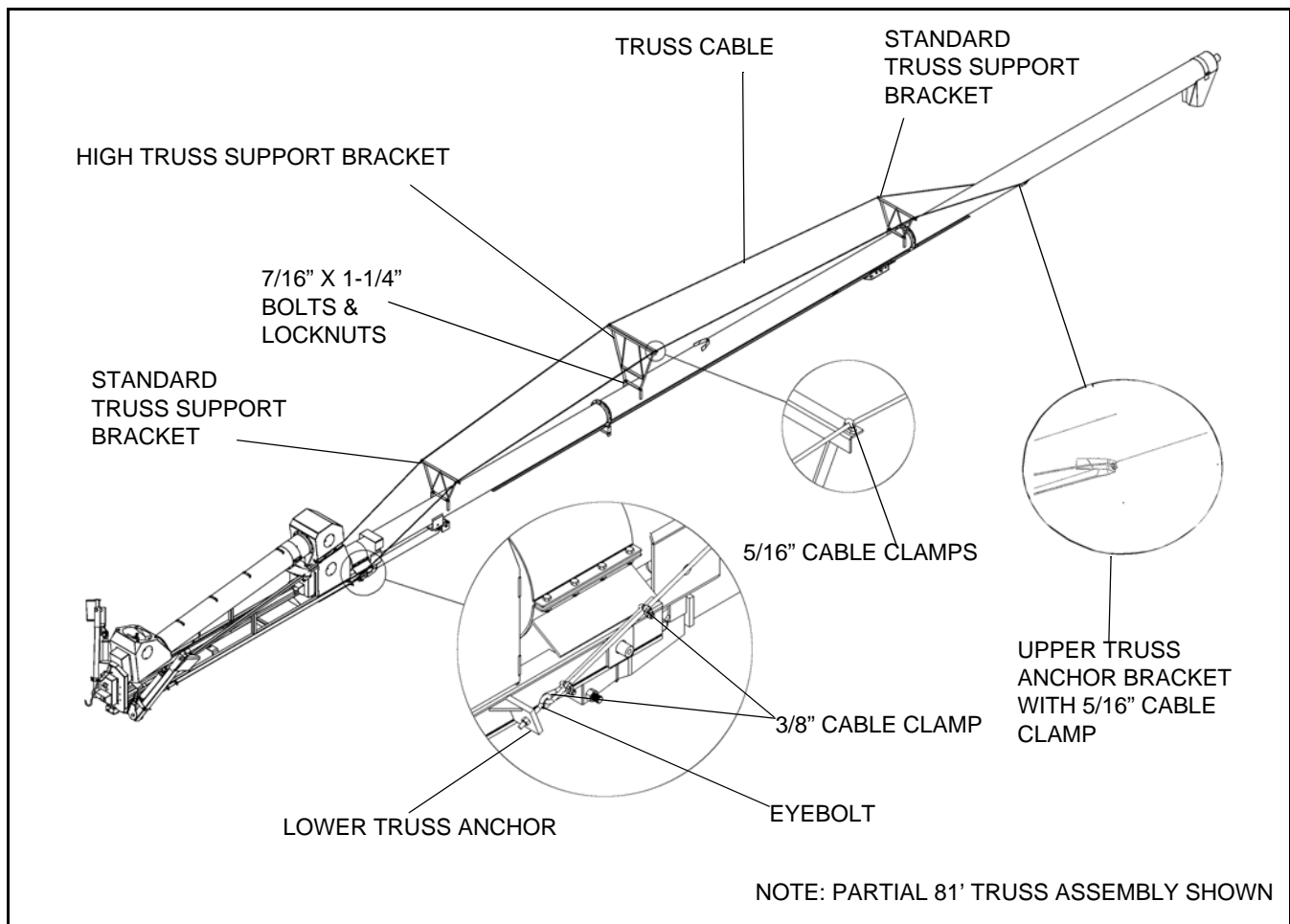

**Figure 3.23 Truss Components**

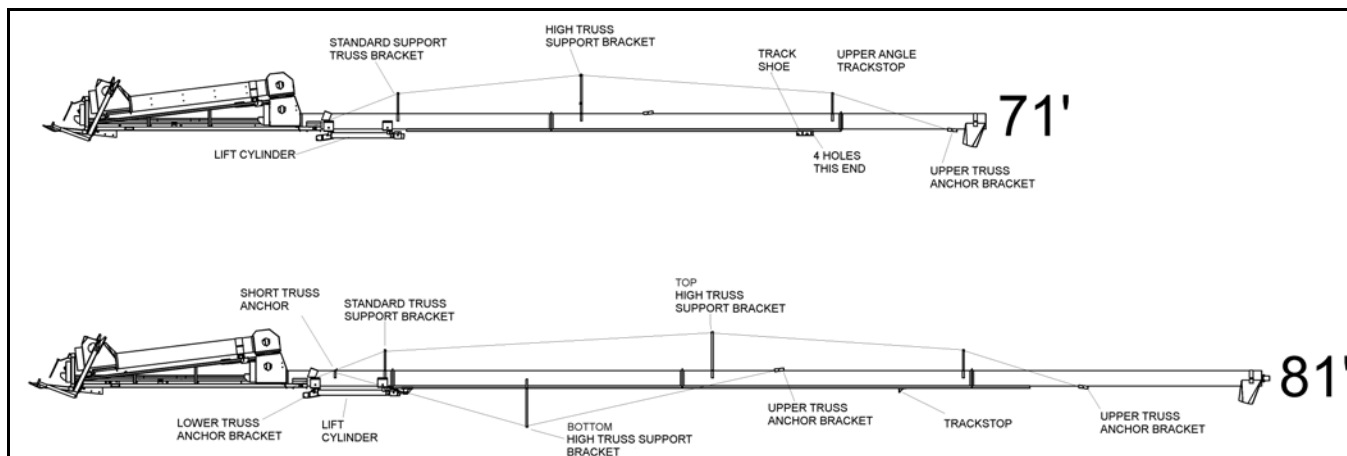

**Figure 3.24 Flex 71' & 81' Auger Complete Truss Layout**

## 3.10. TRUSS (91'–111')

---

When assembling the truss system, **do not tighten** any bolts until all components are in place. Refer to Figure 3.25 on page 37 for correct positioning of the truss components.

- ➔ 1. Loosely attach the 2 low pairs of truss towers (D) and 57 (111') high pairs of truss towers (C) to the truss-attach brackets welded to auger tube with 7/16" x 1-1/4" bolts and locknuts.
- 2. Loosely join the ends of two 10' (3.05 m) truss tubes (A) and two crossbrace tubes (B) between the top end of each pair of high truss towers using 1/2" x 2-3/4" bolts and locknuts.
- 3. Thread a 3/4" nut onto each adjust-tube, then insert threaded end into truss-anchors on lower and upper auger tubes. Join the adjust tubes (E) and 10' truss tubes (A) at the two low (D) truss towers with 1/2" x 2-3/4" bolts and locknuts.

**Note:** A single crossbrace tube is positioned between the low (D) truss towers and adjacent high (C) truss towers.

- 4. Loosely join all the crossbrace tubes to tabs welded to top of truss-attach brackets using 1/2" x 1-1/2" bolts and locknuts.

**Note:** *Attach these tubes to same side of tab as they are attached to the truss tower.*

- 5. Tighten all bolts and nuts.
- ➔ 6. Install the 5 (111') pairs of x-clamps where the crossbrace tubes meet with two 7/16" x 1" bolts and locknuts on each.
- 7. Thread a second 3/4" nut on the end of the adjust tube, then adjust the threaded adjust tubes until upper and lower auger tubes have a slight upward bow. Lock the adjust nuts against bracket.

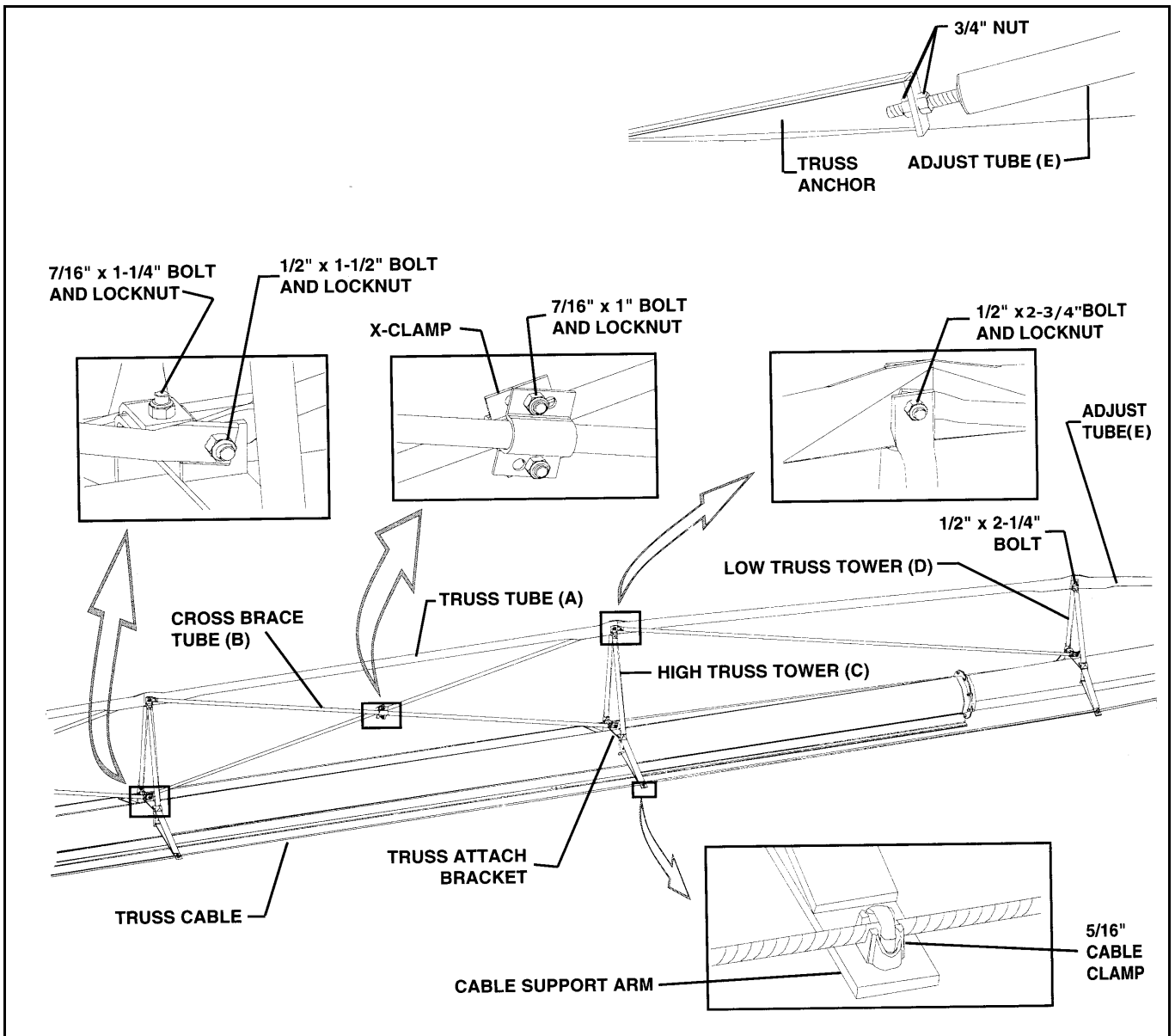

Figure 3.25

### 3.10.1. CABLE TRUSSING (91'-111')

1. Attach an eyebolt to one end of each of two truss side cables with two 3/8" cable clamps using about 10" (25.4 cm) to 12" (30.5 cm) of cable. Tighten securely (Figure 3.26).
2. Insert eyebolts into tabs located on flex frame. Secure with 1/2" locknut (Figure 3.26).
3. Loosely attach the truss cables to each cable support arm with a 5/16" cable clamp as shown in Figure 3.25.
- ➔ 4. **For 91'**: Pull longer cable around truss cable anchor at top end of auger tube and loosely attach with a 5/16" cable clamp (Figure 3.27).
- ➔ 5. **For 111'**: Attach remaining eyebolts to adjust bracket and thread on 1/2" locknuts about 1/2" (Figure 3.26).
- ➔ 6. **For 111'**: Thread loose ends of the cable through each eyebolt, pull tight, then secure with two 3/8" cable clamps (Figure 3.26). Tighten securely.
7. Adjust tension of side truss cable by tightening the eyebolts at the adjust brackets. These cables must be very tight. Also adjust for side alignment.
8. Now tighten all of the cable clamps at cable supports and arms.

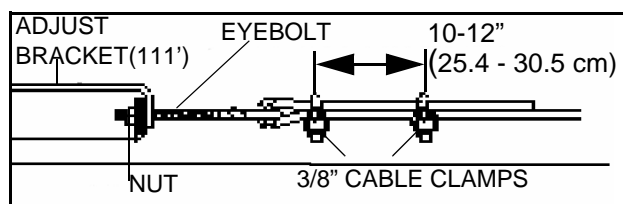
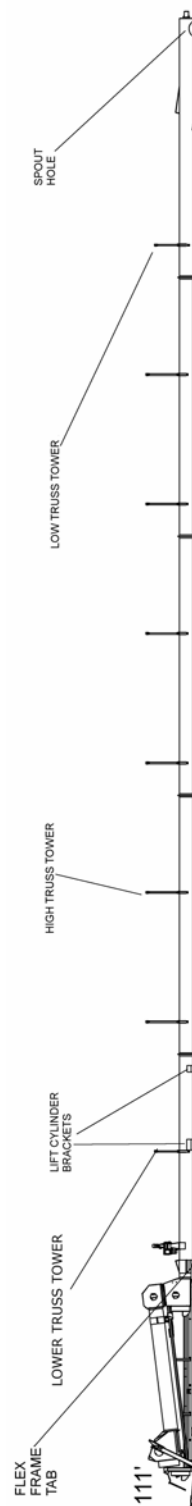

Figure 3.26 111' Only



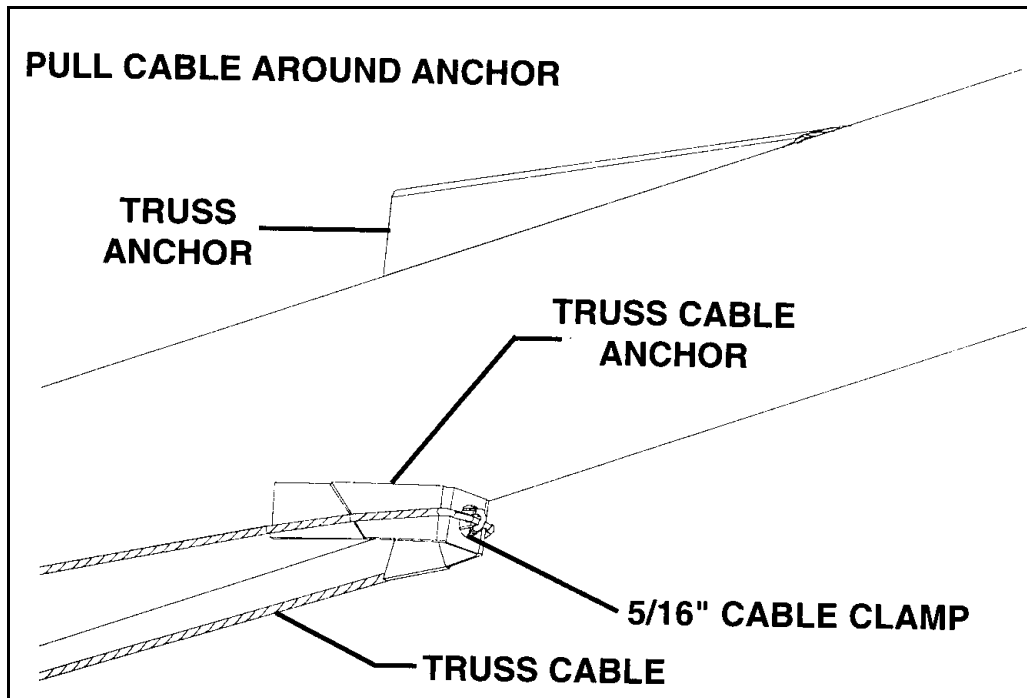

Figure 3.27

### 3.11. TRANSPORT UNDERCARRIAGE (71'-81')

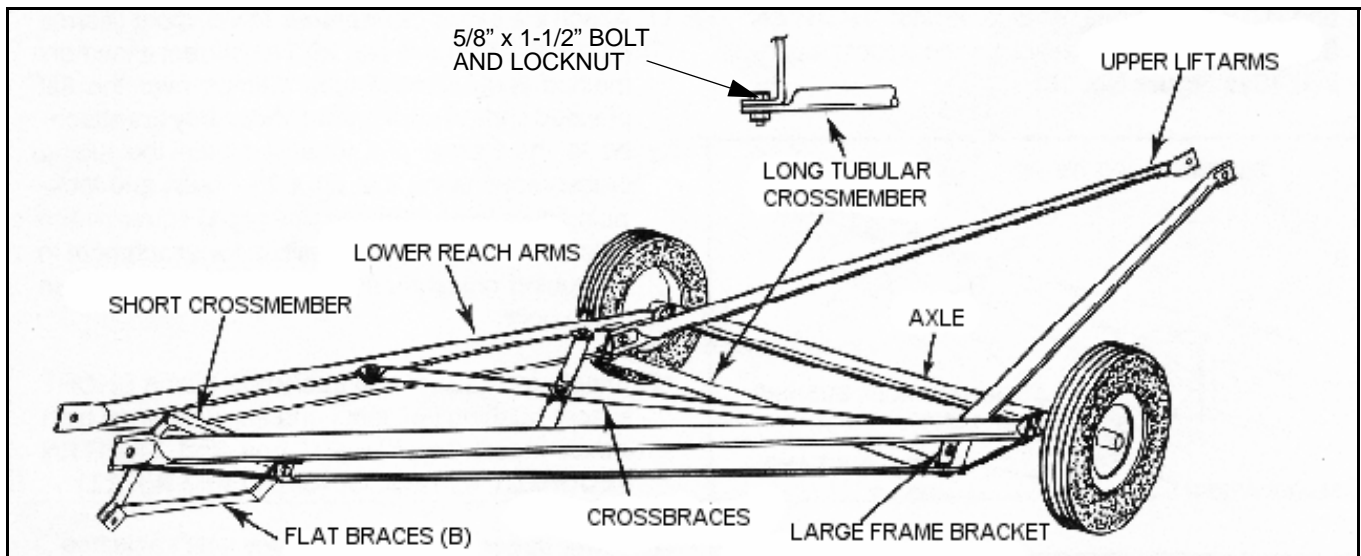

Figure 3.28 MK Flex 71'

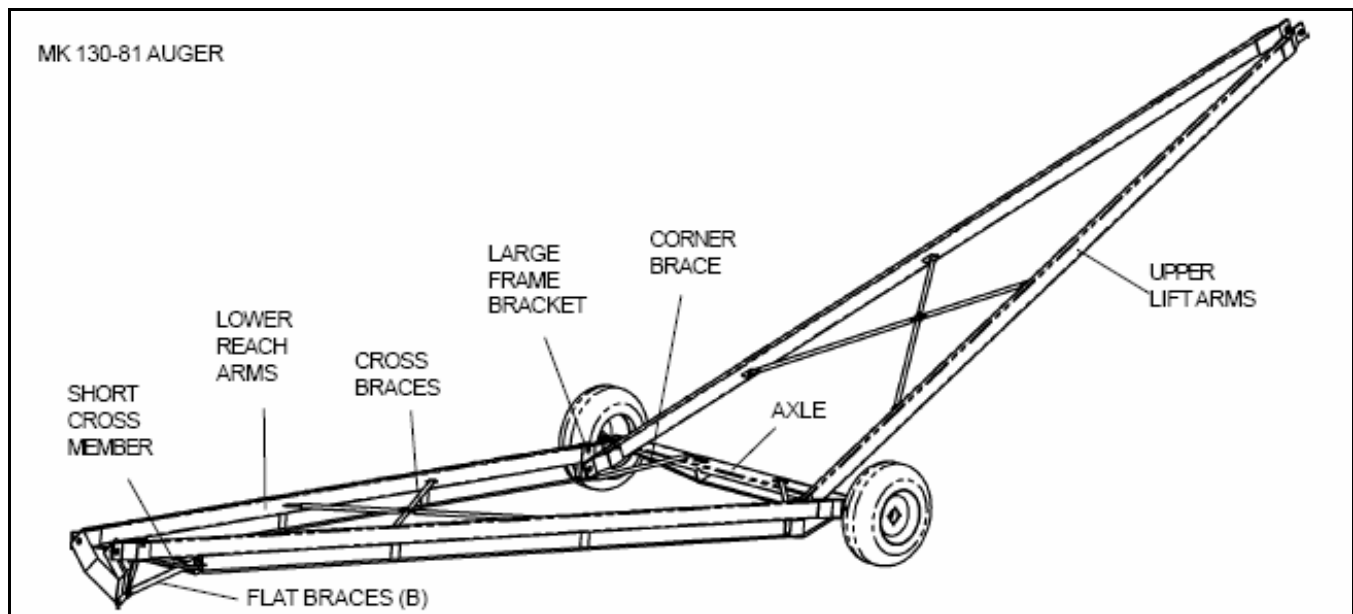

Figure 3.29 81'

1. Fasten the lower reach arms to the axle with three 5/8" x 2" bolts and locknuts on each side.
- ➔ 2. **71'**: Attach long tubular crossmember to bottom of large frame brackets (Figure 3.28), with two 5/8" x 1-1/2" bolts and locknuts.
- ➔ 3. **81'**: Install 2 corner braces with 1/2" x 1-1/4" bolts and locknuts as seen in Figure 3.29.
4. Loosely attach short crossmember to small frame brackets with two 5/8" x 2" bolts and locknuts, sandwiching the flatbraces (B) between the short crossmember and small frame brackets on each side (Figure 3.32). Leave loose until step 10.
5. Secure the crossbraces to the welded tabs on the lower reach arms with four 1/2" x 1-1/4" bolts and locknuts, and a fifth bolt and locknut where the braces cross. Tighten securely.
- ➔ 6. **81'**: Insert axle extensions into axle and pin in place using a 3/8" x 5-1/2" pin and hair pin.
7. Wheel hub assembly:
  - a. Remove any dirt or paint from spindle and hub.
  - b. Thoroughly pack wheel bearings and cups with a good grade of bearing grease.
  - c. Place large bearing into hub and carefully tap in seal.
  - d. Slip hub onto spindle and insert small bearing.
  - e. Tighten slotted spindle nut until hub drags slightly. Back off nut about 1/4 turn until hub turns freely.
  - f. Install cotter pin and dust cap.

**Note:** *Installing tires may not leave you with enough clearance to position and attach undercarriage once auger tube is raised. If so, install wheels after assembly is complete.*



- g. Install 16" tires and rims provided on hubs. Check inflated according to recommendation on tire side-wall. Wheels may be mounted on hubs at this time with six 1/2" x 1-5/8" wheel bolts.
- 8. Fasten upper lift arms to lower reach arms using two short spacer bushings (3/4" long), flat washers, and 1" x 3-1/2" bolts and locknuts. **Tighten securely.** Lift arms pivot on the spacer bushings (Figure 3.31).

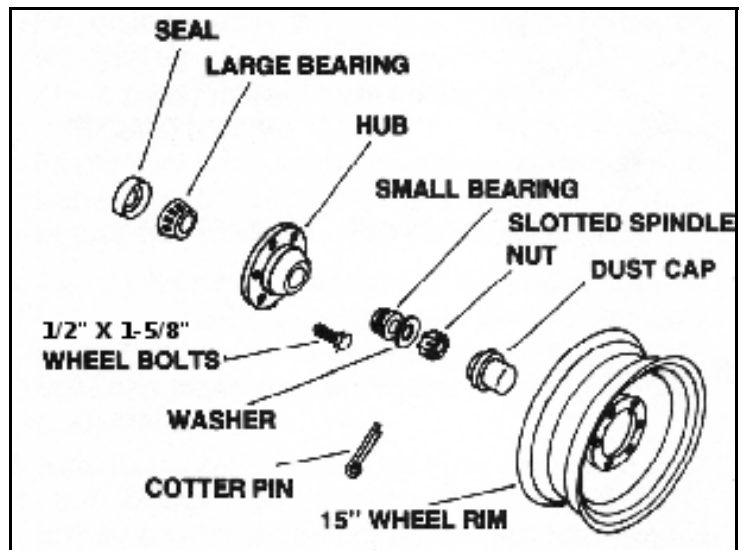

Figure 3.30

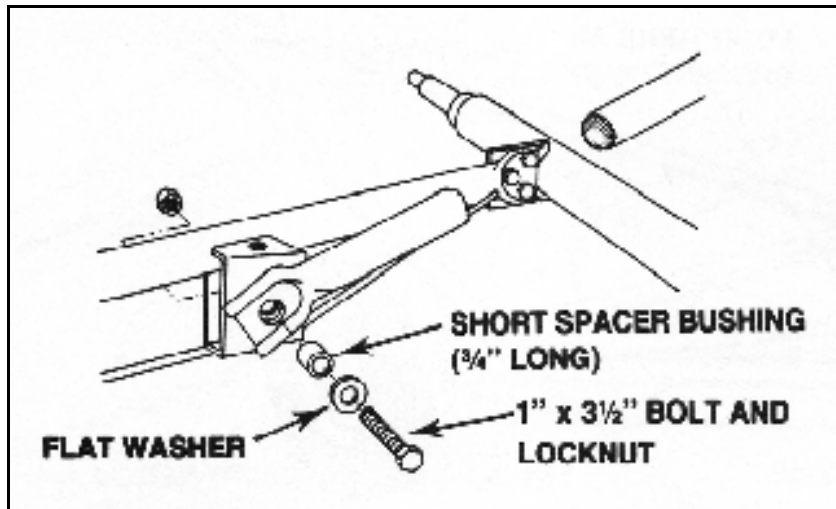
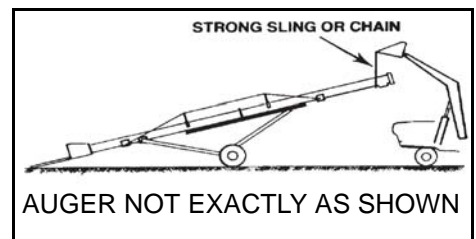
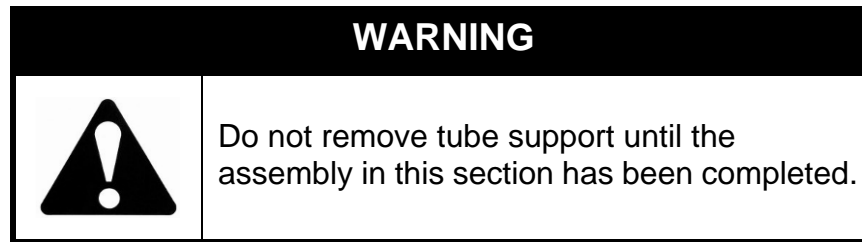

Figure 3.31

- 9. Raise the discharge end of auger with a front end loader and a strong sling/chain or block and tackle. The height should be sufficient to clear undercarriage assembly.





10. Place undercarriage beneath tube assembly.
11. Position stabilizer braces (A) (Figure 3.32) and attach lower reach arms to bracket on tube with long spacer bushings (1-1/8" long), 1" flat washers, and 1" x 3-1/2" bolts and locknuts. **Tighten securely.** Reach arms pivot on the spacer bushings.

**Important:** Refer to Figure 3.32 for correct placement of lower reach arms.

12. Fasten flat braces (B) to first set of holes (furthest from intake) on stabilizer braces (A) with one 5/8" x 2" bolt and locknut. Place one 5/8" x 1-1/2" bolt and locknut in other hole of stabilizer brace.
- ➔ 13. **71'**: Attach the tubing crossbraces to the upper lift arms (Figure 3.32) by slipping the tube clamps over the flat pressed ends of the lift arms (where they are attached to the frame) and loosely attaching the tubing crossbraces using five 1/2" x 1-1/4" bolts and locknuts.
  - Use a large c-clamp vise grip to squeeze and hold the tube clamps in position for attachment of the tubing crossbraces.
  - Once in position, tighten these bolts.
- ➔ • **81'**: Attach the tubing crossbraces to the upper lift arms using five 1/2" x 1-1/4" bolts and locknuts.
- ➔ *The 81' auger does not use tube clamps. The attach tabs are welded onto the upper reach arms.*
- ➔ 14. **71'**: Attach upper lift arms to track shoe. Use a short spacer bushing (3/4" long) and flat washer on both sides; insert the 1" x 10" bolt and **tighten securely** with locknut (Figure 3.32).
- ➔ 15. **81'**: Attach upper lift arms to the center hole on the lift-assist arms as shown in Figure 3.36 using two 15/16" medium spacers, flat washers, and two 1" x 3-1/2" bolts and locknuts. **Tighten securely.** The lift arms will pivot on the spacer bushings.
16. Lower upper end of auger slowly until track shoe rests against upper track stop.
- ➔ *The 81' lift-assist will rest against the track.*

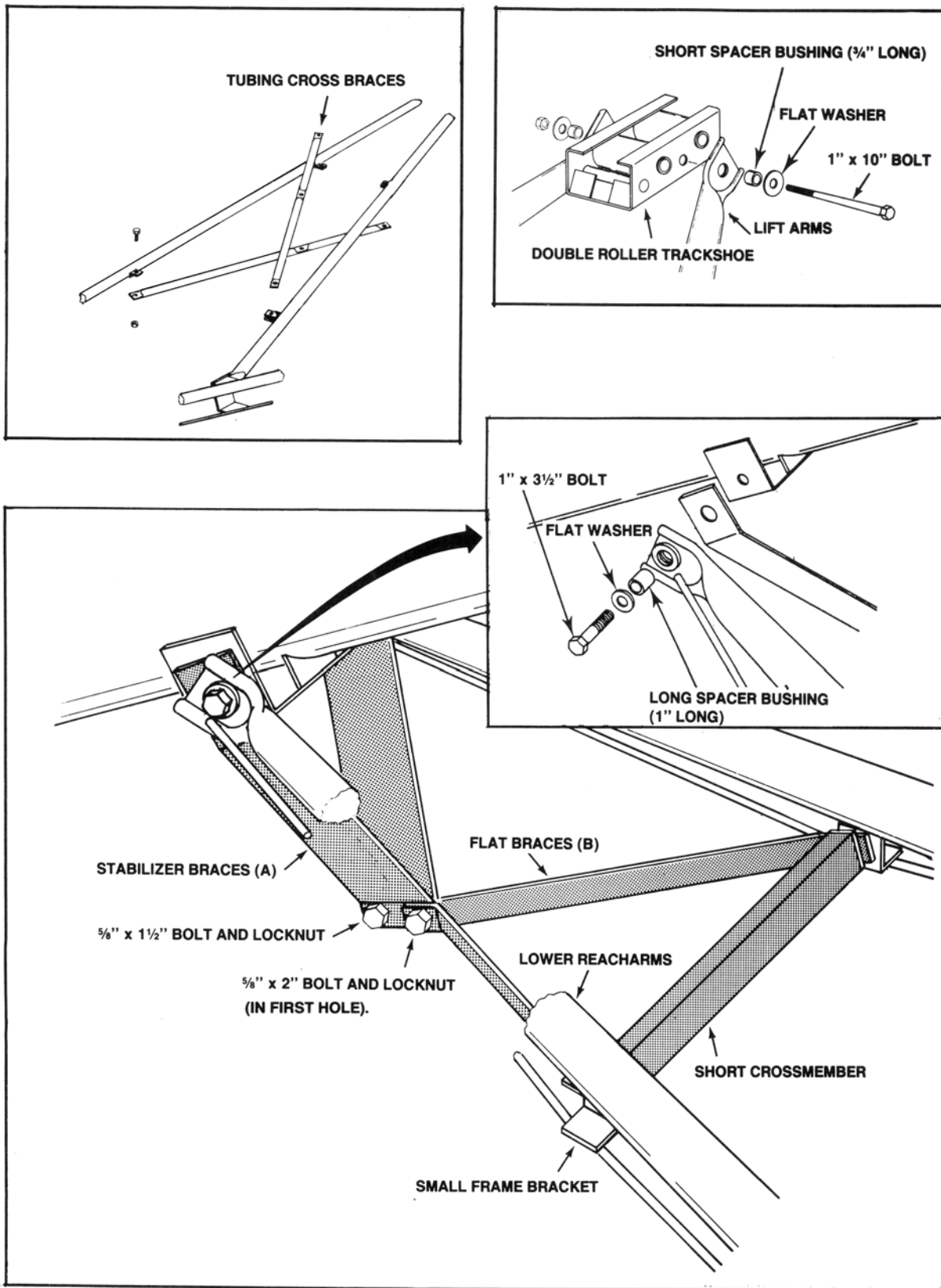

Figure 3.32

## 3.12. TRANSPORT UNDERCARRIAGE (91'–111')

See Figure 3.33.

1. With arch on axle positioned as shown in Figure 3.33, fasten the lower reach arms to brackets on axle with four 5/8" x 2" bolts and locknuts on each side. See Figure 3.34.
2. Attach short crossmember loosely with two 5/8" x 2" bolts and locknuts, sandwiching flat braces (B) between crossmember and frame bracket. Do not tighten bolts until undercarriage is beneath tube assembly (Figure 3.35).
3. Secure the tubing crossbraces to welded lugs on lower reach arms with four 1/2" x 1-1/4" bolts and locknuts, plus a fifth bolt and locknut where the braces cross.



- On the **111' auger**, add a tie tube between the bottom welded lugs. Use 1/2" x 1-3/4" bolts and locknuts.
4. Attach the corner braces on the 91' auger (axle crossbraces on the 111' auger) with two 1/2" x 1-1/4" bolts and locknuts each.
  5. Insert axle extensions into axle and pin in place using a 3/8" x 5-1/2" pin and hair pin.
  6. Wheel hub assembly:
    - a. Remove any dirt from spindle and hub.
    - b. Thoroughly pack wheel bearings and cups with a good grade of bearing grease.
    - c. Place large bearing into hub and carefully tap in seal.
    - d. Slip hub onto spindle and insert small bearing and washer.
    - e. Tighten slotted spindle nut until hub drags slightly. Back off nut about 1/4 turn until hub turns freely.
    - f. Install cotter pin and dust cap.

**Note:** *Installing tires may not leave you with enough clearance to position and attach undercarriage once auger tube is raised. If so, install wheels after assembly is complete.*

- g. Install the assembled tires and rims provided onto the hubs at this time using 6 wheel bolts.
7. Fasten upper lift arms to lower reach arms using two 15/16" spacer bushings, flat washers, and 1" x 3-1/2" bolts and locknuts. Tighten securely; lift arms pivot on the spacer bushings (Figure 3.34).
  8. Secure the tubing crossbraces to welded lugs on upper lift arms with four 1/2" x 1-1/4" bolts and locknuts plus a fifth bolt and locknut where the braces cross.



- On the **111' auger**, add a tie tube between the bottom welded lugs as shown in Figure 3.33. Use 1/2" x 1-3/4" bolts and locknuts.

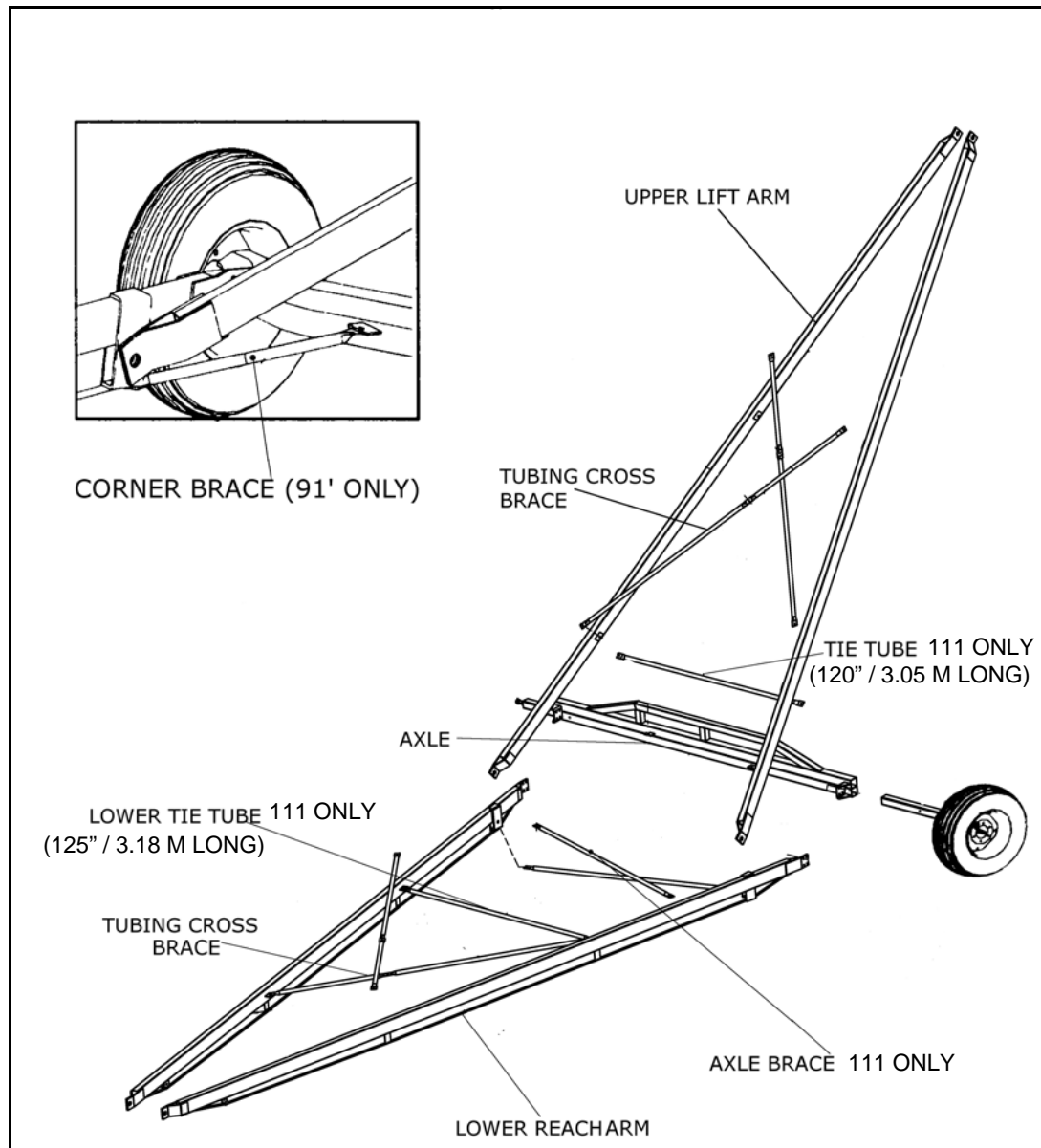

**Figure 3.33**

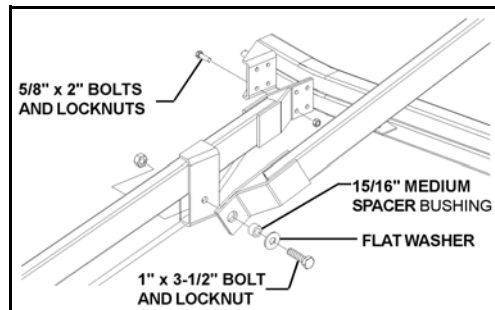

**Figure 3.34**

9. Lower auger intake to the ground.

10. Raise the upper end of auger with a block and tackle or a front-end loader. Securely attach a strong sling or chain about 36" (0.91 m) above trackstop. Secure tube to prevent it from turning while lifting. Raise sufficiently to clear undercarriage.

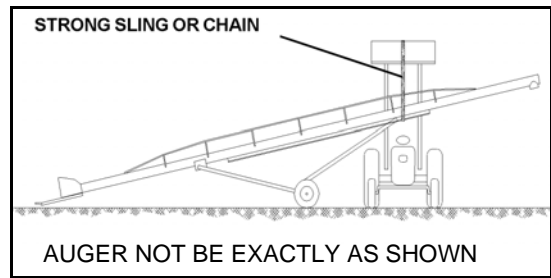

WARNING	
	Do not remove tube support until assembly in this section has been completed.

11. Place undercarriage beneath tube assembly.
12. Position stabilizer braces (A) (Figure 3.35) and attach lower reach arms to bracket on tube with long spacer bushings (1-1/8" long), flat washers, and 1" x 3-1/2" bolts and locknuts. **Tighten securely.** Reach arms pivot on the spacer bushings.

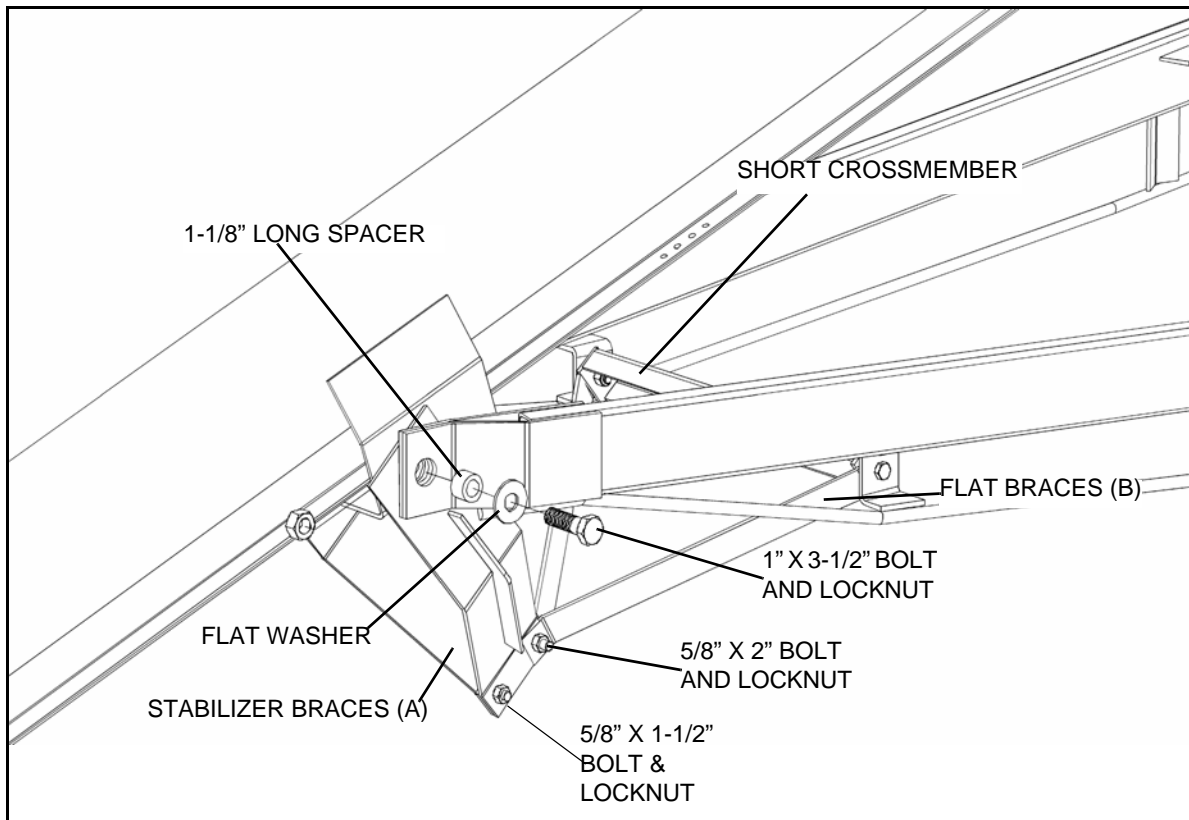

Figure 3.35

13. Fasten flat braces (B) to first set of holes (furthest from intake) on stabilizer braces (A) with one 5/8" x 2" bolt and locknut. Place one 5/8" x 1-1/2" bolt and locknut in other hole of stabilizer brace.

14. Attach upper lift arms to center hole on the lift-assist arms (Figure 3.36) with two 15/16" medium spacers, flat washers, and two 1" x 3-1/2" bolts and locknuts. **Tighten securely**; lift arms will pivot on the spacer bushings.

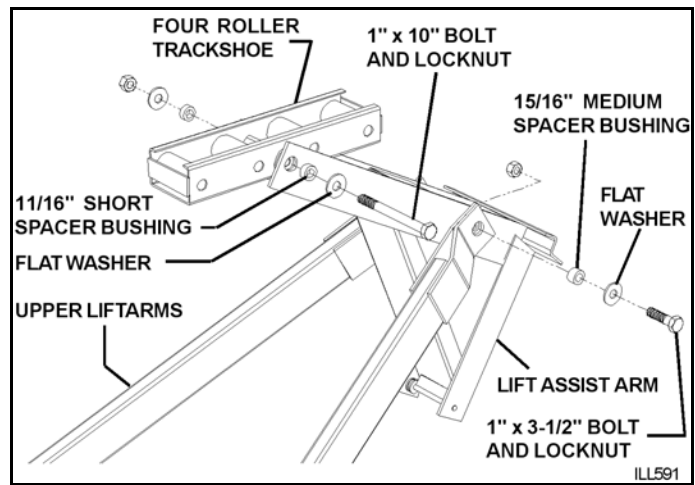

Figure 3.36

15. Lower discharge end of auger slowly until track shoe rests against trackstop and the lift-assist arm rests against track.

## 3.13. LIFT CABLES

**Note:** Determine right or left side of auger by standing at intake end facing top discharge end.

### 3.13.1. MK FLEX 71'

1. Secure the solid connector end of the short cylinder connector hydraulic hose to above elbow fitting on right side lift cylinder. Use thread sealant (not supplied). The other end of this short hose is secured later.

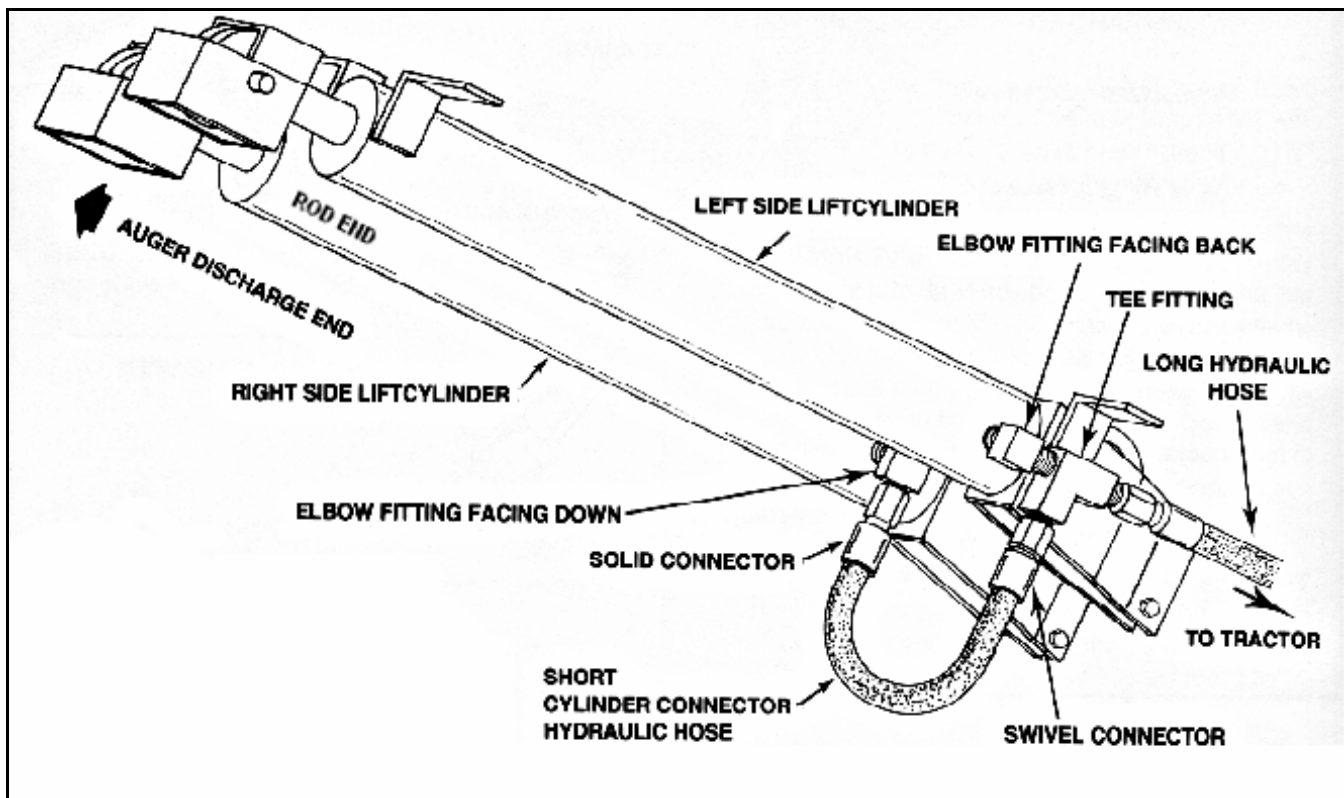



Figure 3.37

<b>CAUTION</b>	
	<p>Track shoe must rest against track stop when adjusting cable.</p> <p>Failure to heed will allow auger to raise higher than designed to lift, resulting in damage to auger and injury to personnel.</p>

**Note:** Although the lift cable is factory installed on the cylinder, make sure that the cable clamps on the cylinder are secure and the cables are properly seated in the cable sheaves before attaching the cable to the track shoe.

2. With both cylinders in full down position and track shoe resting against the track stop, thread both cables over the cable-attach-rod on the track shoe. Pull cable very tight, then secure with three 5/16" cable clamps on each cable, positioned as shown (Figure 3.38). Tighten securely. Tie up excess ends of lift cable with tape or ty-wrap.

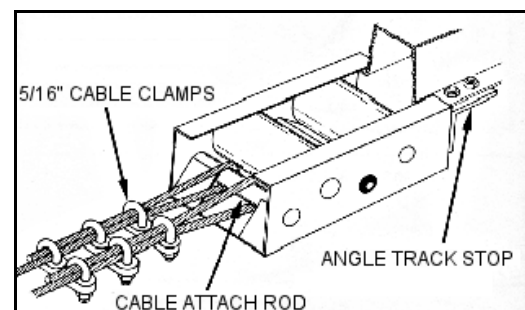

Figure 3.38

**Important:** Lift cable will stretch with initial use. Check frequently and adjust.



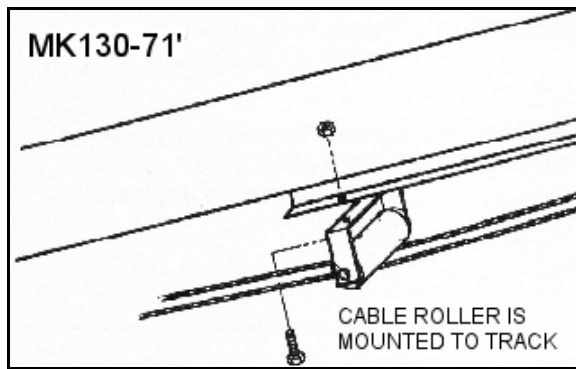

Figure 3.39

3. Attach the cable-roller to the appropriate location on lower end of the track with two 7/16" x 1-1/4" bolts and locknuts (Figure 3.39).
  - Attach the cable-roller to lower end of track.

### 3.13.2. MK FLEX 81'–111'

1. Seat lift-assist arm against the track and place both lift cylinders in full down position (fully retracted).

**Important:** *Lift cables may stretch with use. Check frequently and adjust when necessary.*



2. Thread the lift cables over the respective pulleys on the lift-assist arm, pull cables tight, and secure with three 5/16" (3/8" on 111') cable clamps on each cable. Tighten securely. Do not crisscross cables (Figure 3.40).

**Note:** *Although the lift cables are factory installed on the lift cylinders, make sure the cable clamps on the cylinders are secure and the cables are properly seated in the cable sheaves before attaching the cables to the lift-assist arm.*

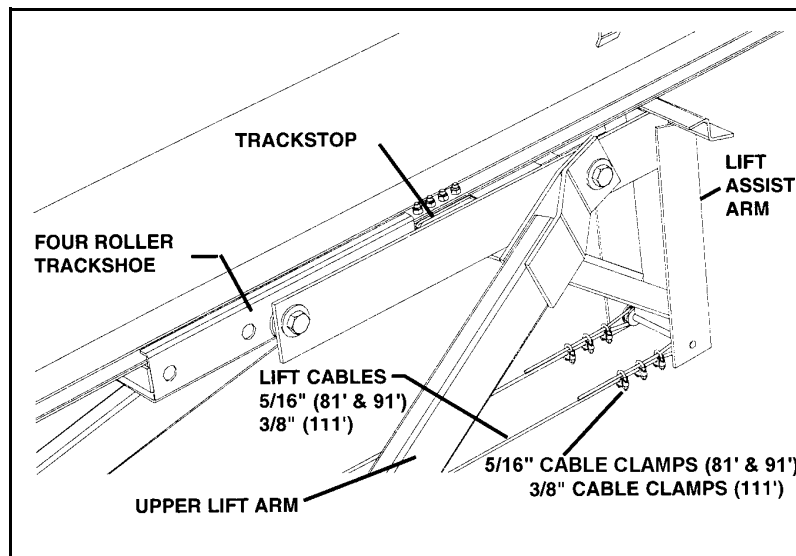



Figure 3.40

CAUTION	
	<p>Track shoe must rest against track stop when adjusting cable.</p> <p>Failure to heed will allow auger to raise higher than designed to lift, resulting in damage to auger and injury to personnel.</p>

## 3.14. HYDRAULIC HOSES

---

**Note:** *Determine right or left side of auger by standing at intake end facing top discharge end.*

### 3.14.1. MK FLEX 71'

---

**Note:** *Elbow fittings are factory installed. Use thread sealant on fitting and hose threads (thread sealant not supplied.)*

1. Rotate the elbow fitting at lower end of lift cylinder so it faces down, making sure it is securely tightened (Figure 3.37).
2. With elbow fitting on left side lift cylinder facing back as shown, secure the tee fitting to the elbow fitting (Figure 3.37).
3. Securely attach the swivel connector end of the short hydraulic hose to tee fitting on left side cylinder (Figure 3.37). Make sure that this short hose is **beneath** the lift cable on left side lift cylinder (Figure 3.41).

**Note:** *Before attaching short connector hydraulic hose to left side lift cylinder, make certain lift cables are tightly stretched and that this hose is positioned beneath lift cable on left side lift cylinder (Figure 3.41). If lift cable is not installed above this hose, it could result in the hose wearing through during operation, causing a hazardous condition.*

WARNING	
	<p>Wear on hose can cause auger to drop suddenly, causing serious injury or death.</p>

4. Securely attach the 272" (6.91 m) long hydraulic hose to tee fitting (Figure 3.41). Place this hose into brackets welded to side of auger tube and boot. Bend tops of these brackets over slightly to hold hose in place.

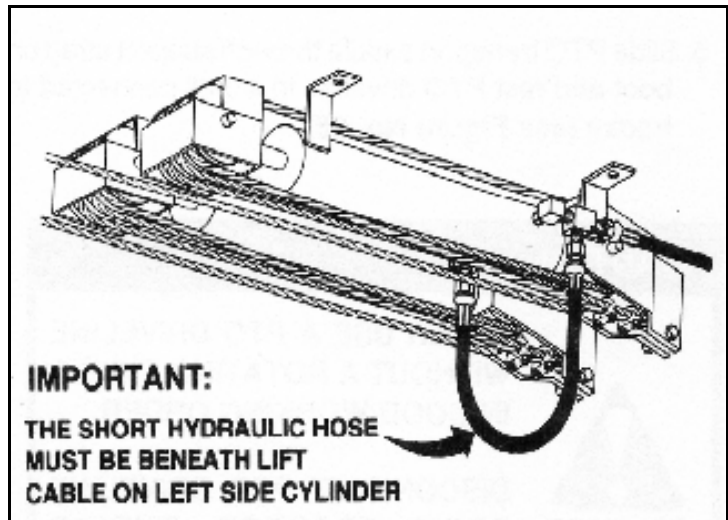

Figure 3.41

**Important:** *Protect hose ends from dirt.*

5. Recheck that bolts on undercarriage, lift cylinders, and cable clamps are tight, then remove auger tube support.

### 3.14.2. MK FLEX 81'

- **Lower** fittings refer to those closer to boot end of auger.
- **Upper** fittings refer to those closer to discharge end of auger.

**Note:** *Use thread sealant (not supplied) on hydraulic connections.*

1. Position both elbow fittings on **right lift cylinder**. The **lower** one should face forward and downward at approximately 45°. The **upper** one should face rearward and downward at approximately 45° (Figure 3.42). Make certain they are tight.
2. Secure the solid connector end of the short (17" / 43.2 cm) cylinder-connector hydraulic hose to the lower elbow fitting.
3. Secure the solid connector end of the long (32" / 81.3 cm) cylinder-connector hydraulic hose to the right upper elbow fitting.

**Note:** *Before attaching short connector 17" (43.2 cm) hydraulic hose to left side lift cylinder, make certain lift cables are tightly stretched and that this hose is positioned beneath lift cable on left side lift cylinder (Figure 3.37). With lift cable beneath this hose, cable will wear on hose as auger is raised and lowered, causing hose to wear through.*

#### WARNING



Wear on hose can cause auger to drop suddenly, causing serious injury or death.

4. Position the elbow fittings on the **left lift cylinder**. The **lower** one should face forward and downward at approximately 45°. The **upper** one should face rearward and upward at approximately 10°.
5. Secure the tee fittings to the left cylinder elbow fittings and position them as shown in Figure 3.42. Make certain they are securely tightened.
6. Secure the swivel ends of the upper (32" / 81.3 cm) and lower (17" / 43.1 cm) cylinder-connector hoses to the tees as shown.
7. Check upper 32" (81.3 cm) cylinder-connector hose position to ensure there is 8-1/2" (21.6 cm) of clearance to lift cables as shown in Figure 3.42.
8. Attach the 272" (6.91 m) long pressure hydraulic hose with shut-off valve to the lower tee fitting (nearest auger intake).
9. Attach the 347" (8.81 m) return hydraulic hose without shut-off valve to the upper tee fitting (nearest auger discharge end).
10. Thread hoses through back arm attach bracket (Figure 3.42).
11. Place both hoses into retaining brackets welded to side of auger tube and boot. Bend tops of brackets over slightly to hold hoses in place.

**Important:** *Protect hose ends from dirt.*

12. Recheck that bolts on undercarriage, lift cylinders, and cable clamps are tight, then remove auger tube support.

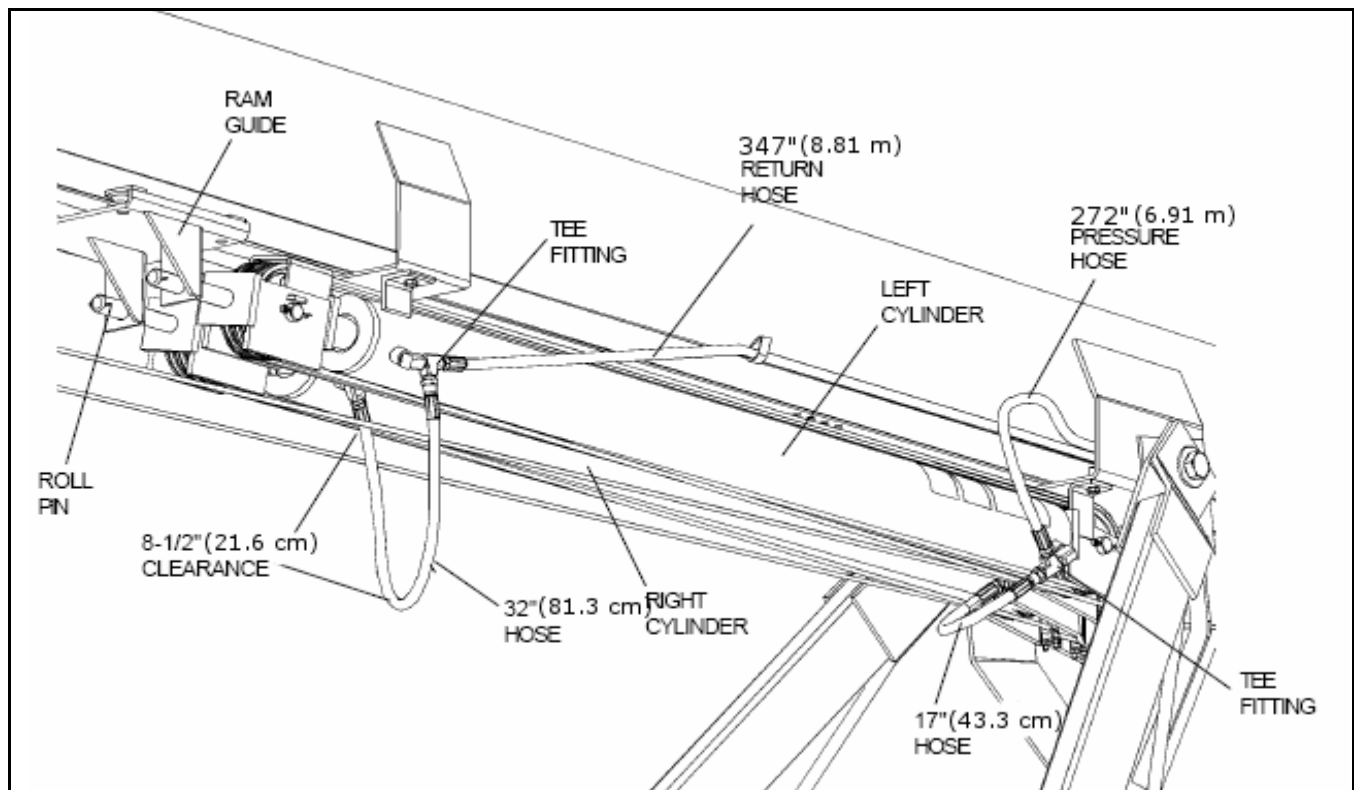

**Figure 3.42 MK130 Plus 81'**

### 3.14.3. MK FLEX 91'–111'

**Note:** *Right or left side of auger, as referred to in this section, is determined by standing at intake end facing top discharge end.*

- **Lower** fittings refer to those closer to boot end of auger.
- **Upper** fittings refer to those closer to discharge end of auger.

**Note:** *Use thread sealant (not supplied) on all hydraulic connections.*

1. Position both elbow fittings on **right cylinder**. The **lower** one should face forward and downward at approximately 45°. The **upper** one should face rearward and downward at approximately 45° (Figure 3.43). Make certain they are tight.
2. Secure the solid connector end of the short (17" / 43.3 cm) cylinder-connector hydraulic hose to the lower elbow fitting.
3. Secure the solid connector end of the long (32" / 81.3 cm) cylinder-connector hydraulic hose to the upper elbow fitting.

**Note:** *Before attaching short connector hydraulic hose to left side lift cylinder, make certain lift cables are tightly stretched and that this hose is positioned beneath lift cable on left side lift cylinder (Figure 3.43). If lift cable is not installed above this hose, it could result in the hose wearing through during operation, causing a hazardous situation.*

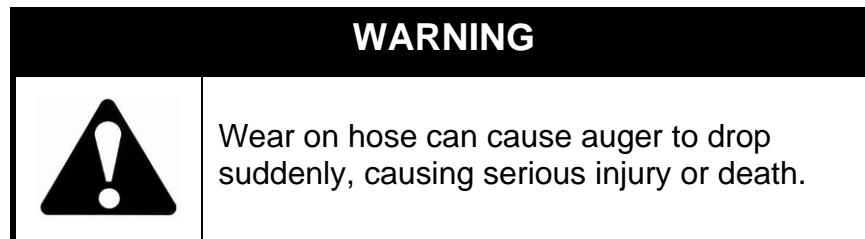

4. Position the elbow fittings on the **left cylinder**. The **lower** one should face forward and downward at approximately 45°. The **upper** one should face rearward and upward at approximately 10°.
5. Secure the tee fittings to the left cylinder elbow fittings and position them as shown in Figure 3.43. Make certain they are securely tightened.
6. Secure the swivel ends of the upper (32" / 81.3 cm) and lower (17" / 43.2 cm) cylinder-connector hoses to the tees as shown.
7. Check upper 32" (81.3 cm) cylinder-connector hose position to ensure there is 8-1/2" (21.6 cm) clearance to lift cables as shown in Figure 3.43.
- ➔ 8. Attach the 336" (8.53 m) long (**91'**) or 392" (9.96 m) long (**111'**) pressure hose with shutoff valve to the lower tee fitting (nearest auger intake).
- ➔ 9. Attach the 403" (10.2 m) long (**91'**) or 473" (12.0 m) long (**111'**) return hose without shutoff valve to the upper tee fitting (nearest auger discharge end).
10. Thread hoses through back arm attach bracket as shown in Figure 3.43.
11. Place both hoses into retaining brackets welded to side of auger tube and boot. Bend tops of brackets over slightly to hold hoses in place.

**Important:** *Protect hose ends from dirt.*

12. Recheck that bolts on undercarriage, lift cylinders, and cable clamps are tight, then remove auger tube support.

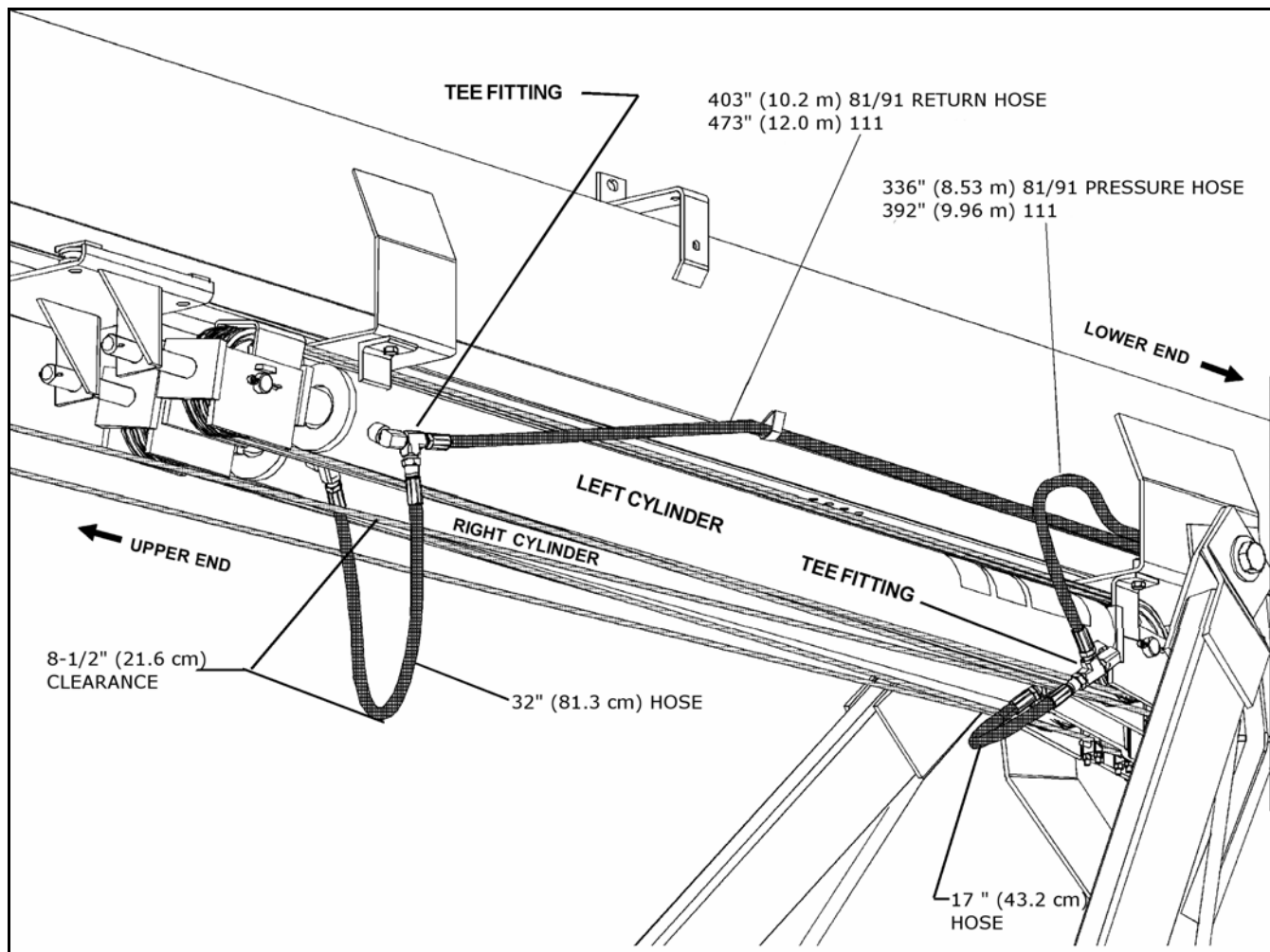

Figure 3.43

### 3.15. PTO (CV) DRIVELINE

1. Clean PTO driveline and drive shaft ends of any paint or dirt.

**Important:** *Ensure that a 3/8" x 3-1/2" square key is installed in the drive shaft before attaching PTO driveline.*

2. Slide plain end of PTO driveline onto drive shaft. Make sure that the holes for the 3/8" roll pin are lined up and square key is in place.
3. Making sure eyes are protected, carefully tap in roll pin. Tighten set screw.
4. Slide PTO transport saddle through support strap on boot and rest PTO driveline in it until connected to tractor.

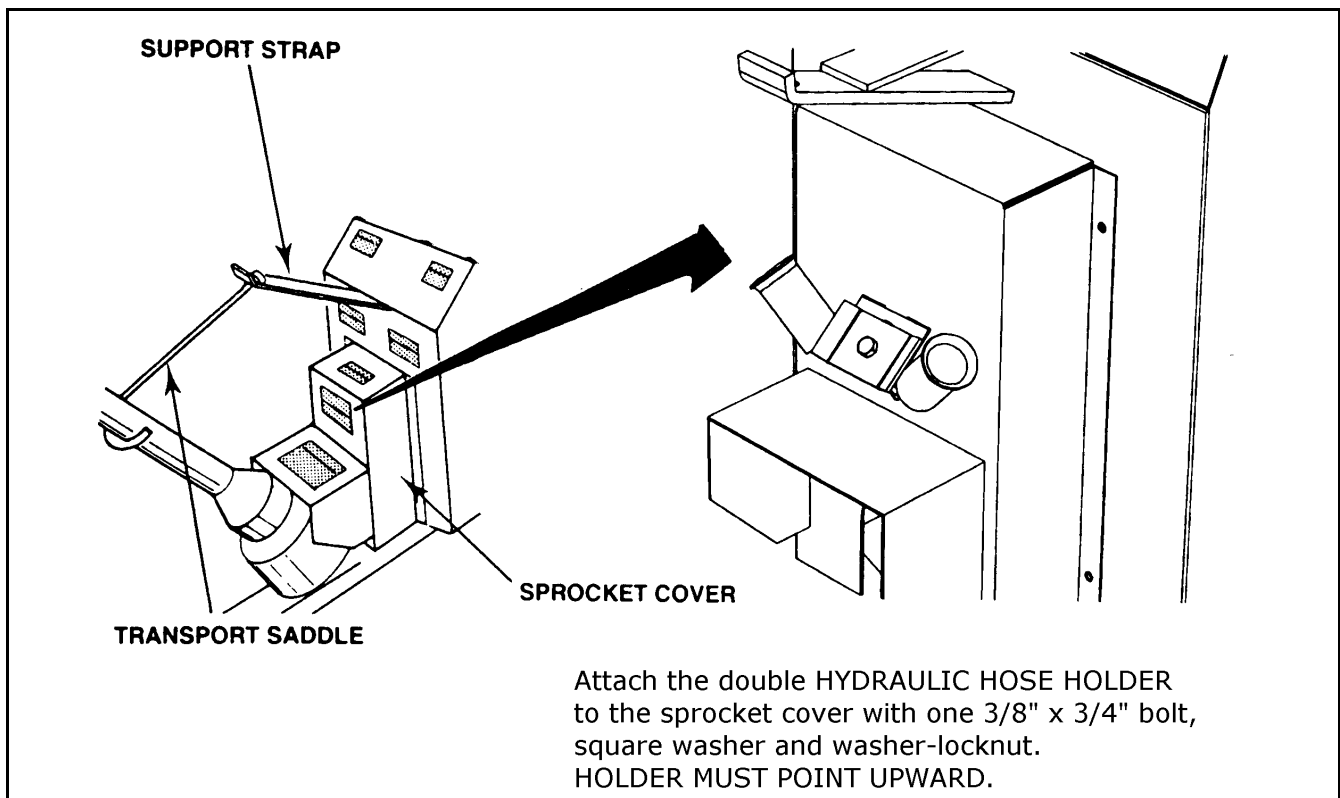

Figure 3.44

## 3.16. LOW PROFILE HOPPER

1. Attach the pivot-connector to the top hole in hopper with two 5/8" x 1-1/2" bolts and locknuts. **Do not over-tighten.** Tighten snug only; these bolts act as pivot points (Figure 3.46).
2. Loosely secure service door with 2 square latch-washers and 3/8" locknuts.

**Note:** *Do not tighten until hopper assembly is completed.*

3. Clean dirt from inside u-joint on hopper and flight shaft end, then insert Woodruff key, see Figure 3.45.
4. Raise and support hopper tube at about 59" (1.5 m) under spout.
5. Open service door on hopper, then bring tube and hopper together guiding flight shaft into u-joint.
6. Secure tube to pivot-connector on hopper with twelve 7/16" x 1-1/4" bolts and locknuts.

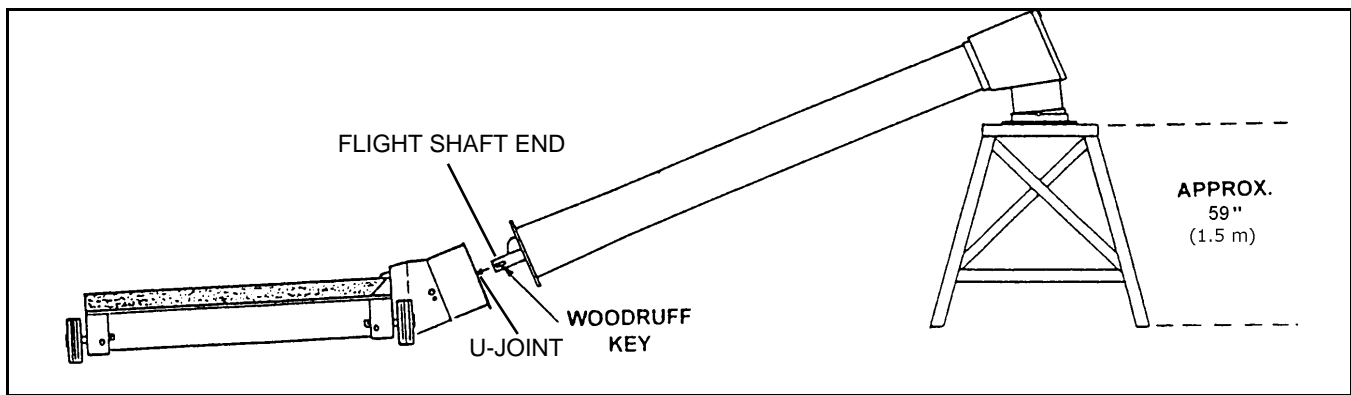

Figure 3.45

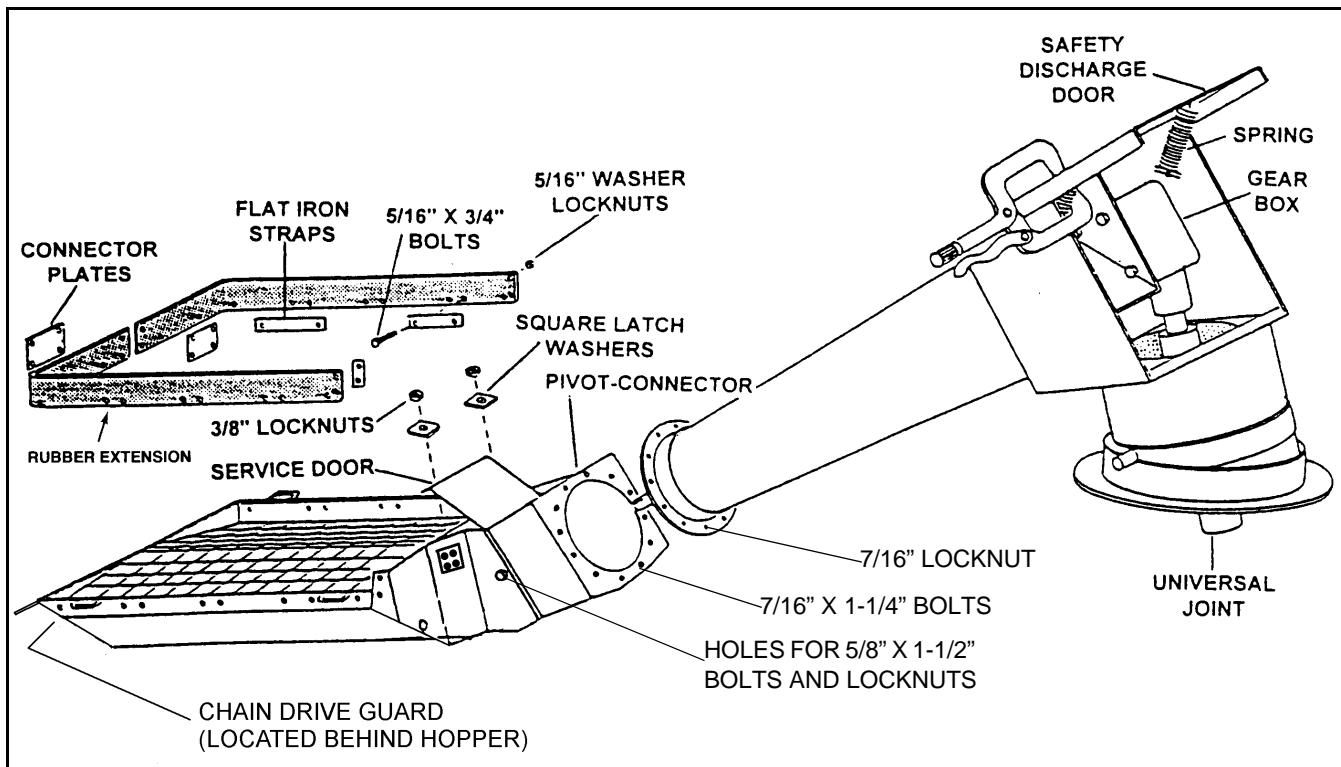

Figure 3.46

7. Tighten set screws on u-joints, then close and secure the service door, tighten 3/8" locknuts and 3/8" square latch washers.
8. Remove the two 5/16" whiznuts that secure the chain drive guard. Attach the 2-piece rubber extension to inside of hopper lip with 5/16" x 3/4" bolts and whiznuts and the flat iron straps provided, plus the 2-piece extension connector plates. Replace bolts, see Figure 3.46.
9. Attach two swivel wheels to the two hopper corners with eight 3/8" x 1" carriage bolts and 3/8" whiz nuts (Figure 3.50).



### 3.16.1. STEERING ASSEMBLY

**Important:** Hoppers can be set up for use on right or left side of auger. Figure 3.47 to 3.51 illustrate the right side as viewed when standing at the hopper looking toward the spout. Figure 3.52 to 3.55 illustrate the left side as viewed when standing at the hopper looking toward the spout.

1. Bolt short and long castor arms to hopper with four 3/8" x 1" bolts and 3/8" flange nuts for each arm (Figure 3.48 and 3.49).
2. Insert steering shaft and motor castors through bearings on each castor arm.

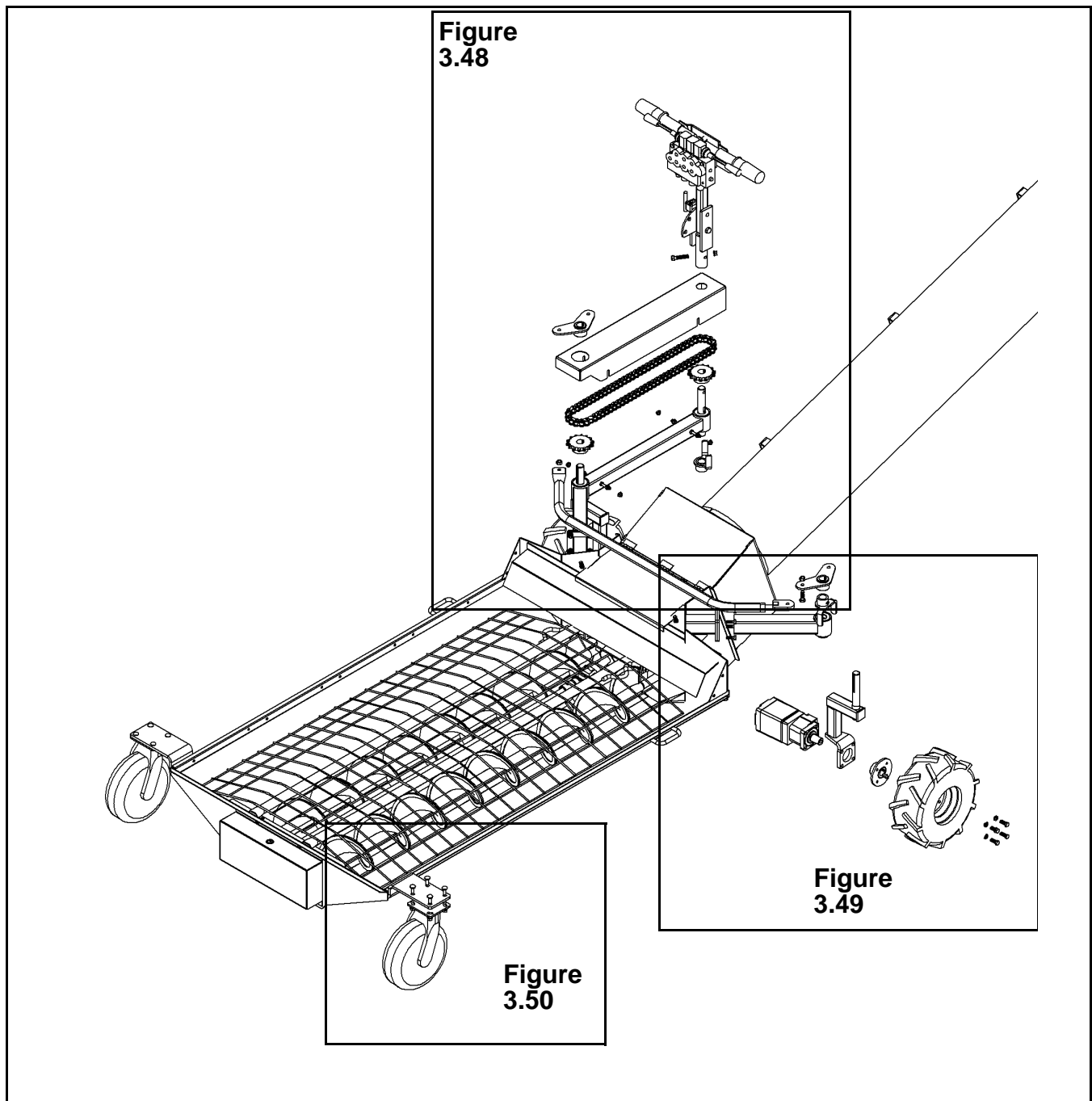
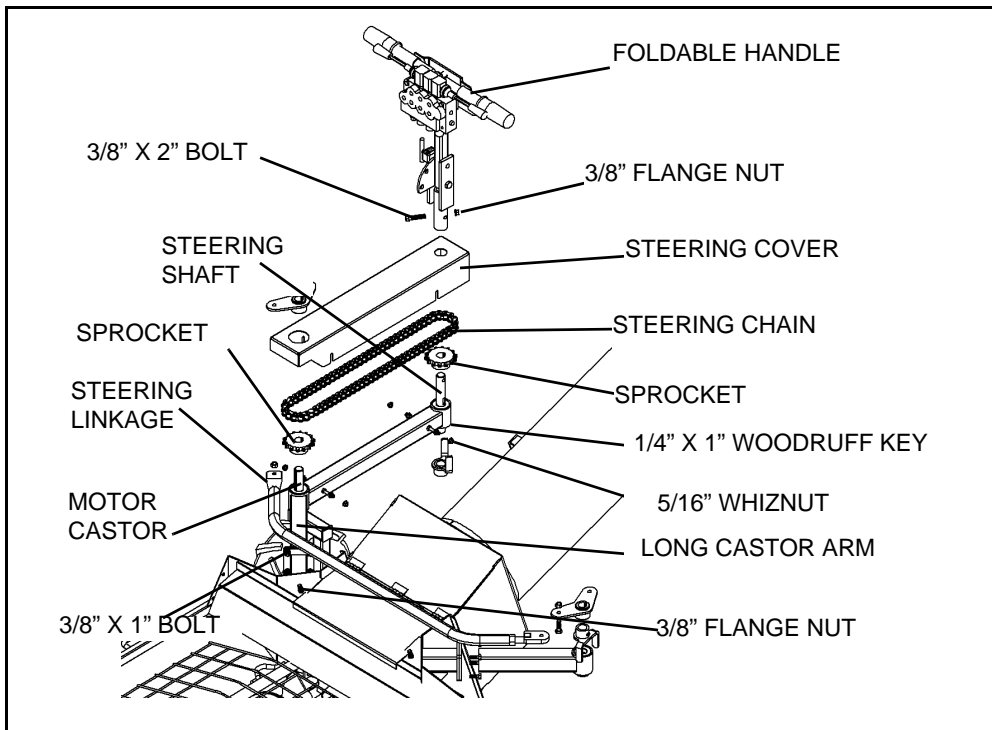
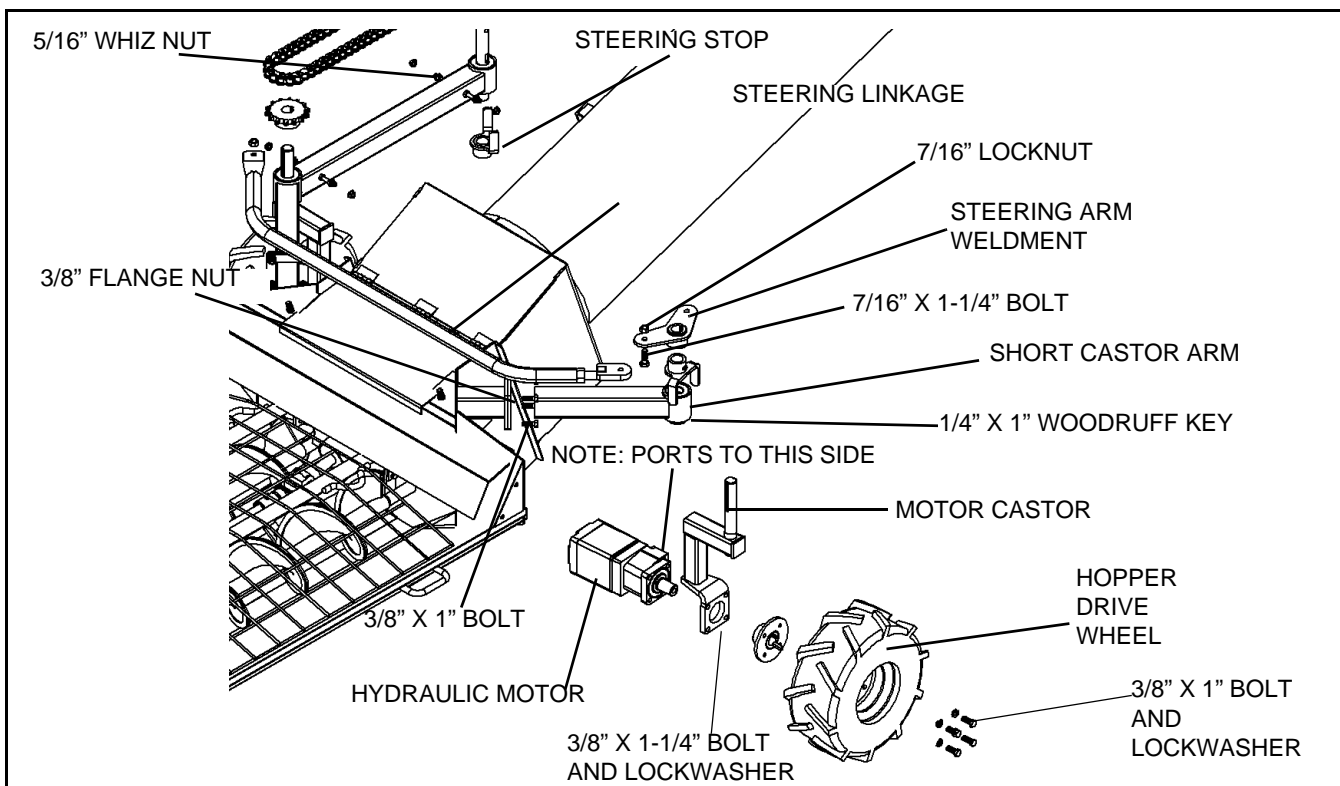

Figure 3.47 Right Side Setup



**Figure 3.48 Right Side Setup**



**Figure 3.49 Right Side Setup**

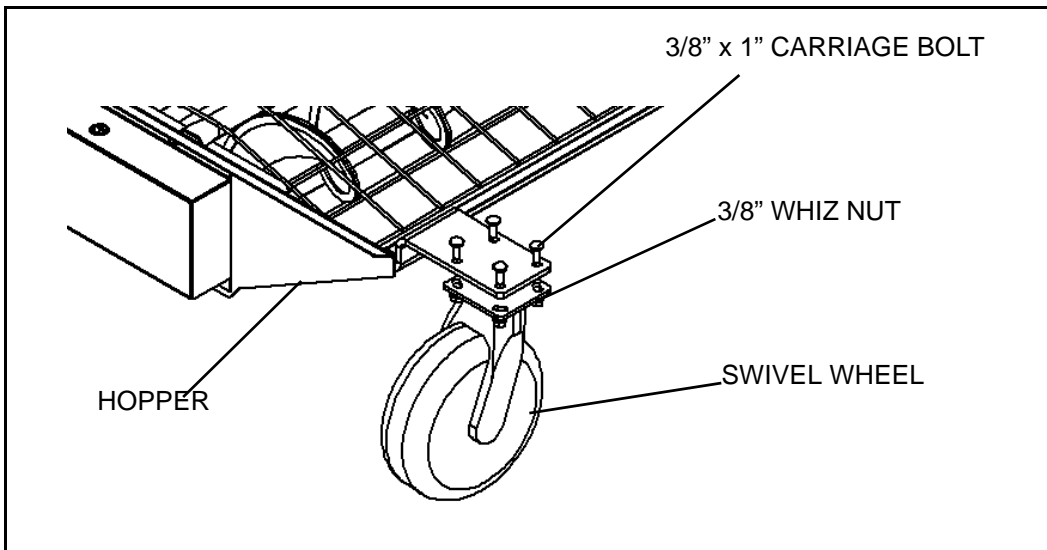

**Figure 3.50 Right Side Setup**

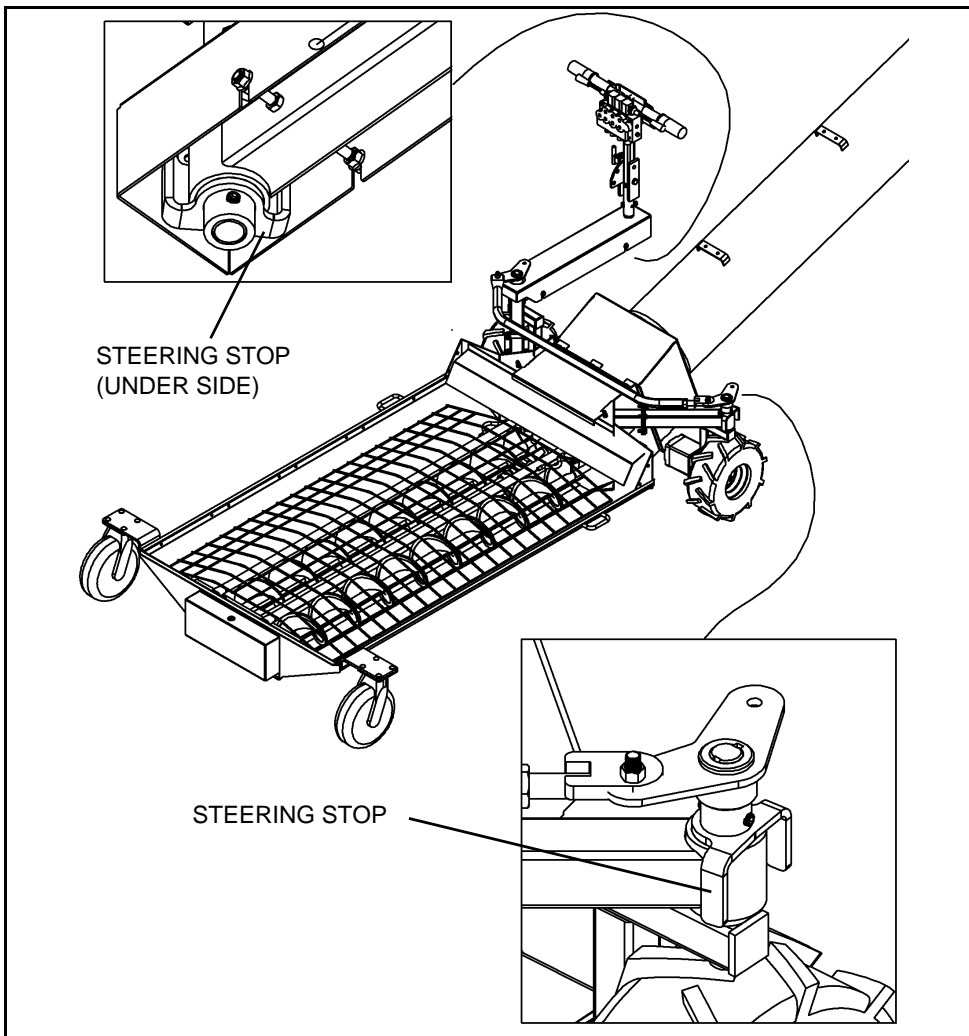

**Figure 3.51 Steering Stop Placement on Right Side Setup**

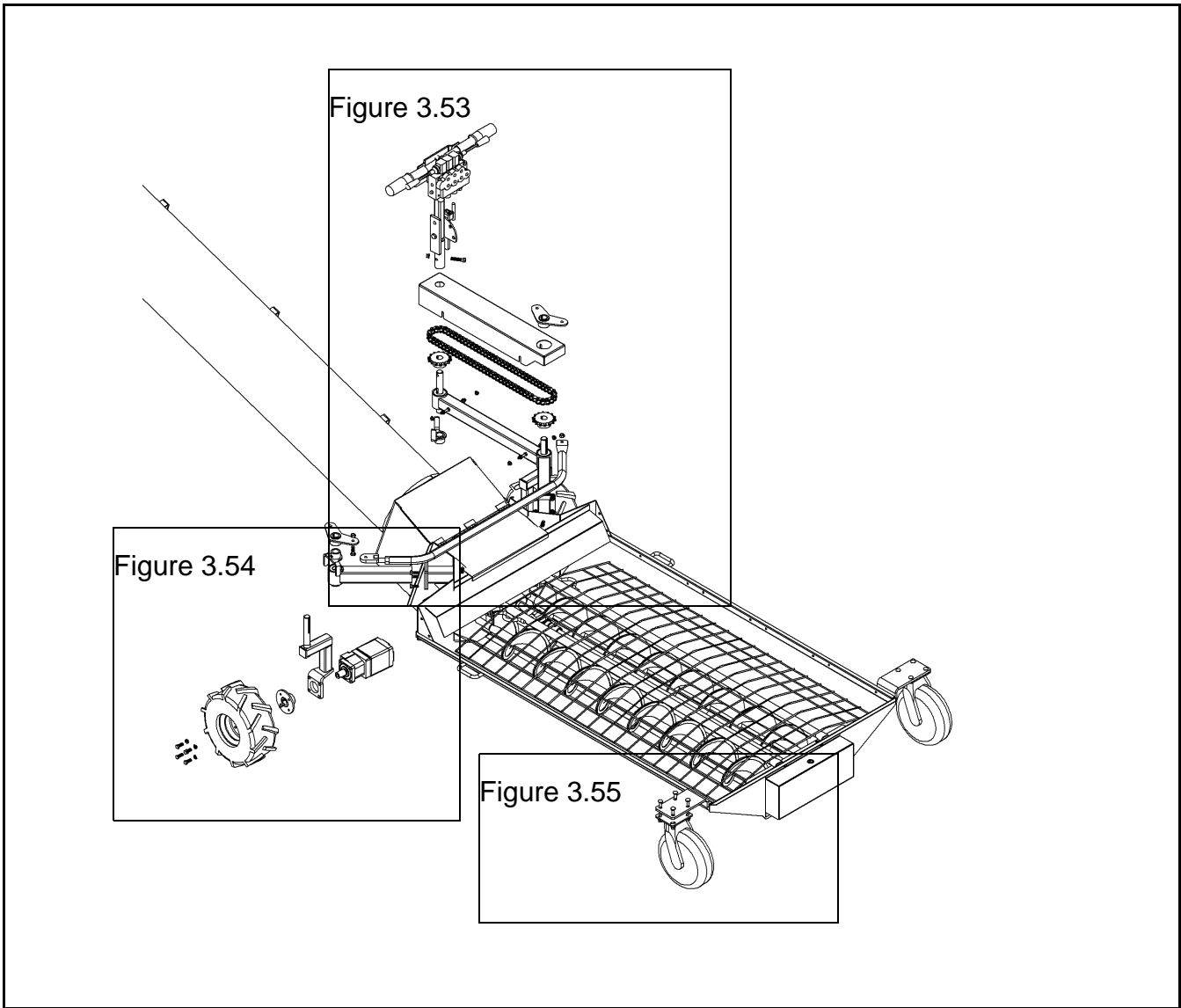

**Figure 3.52 Left Side Setup**

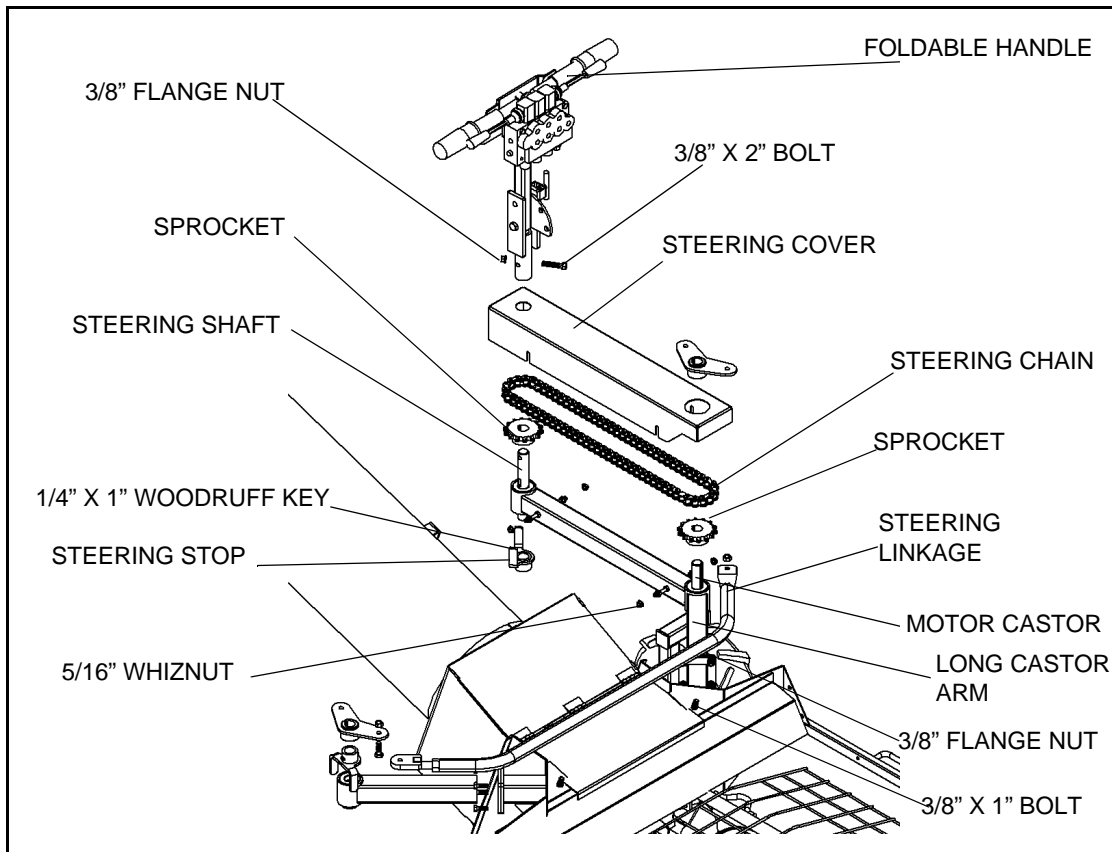

**Figure 3.53 Left Side Setup**

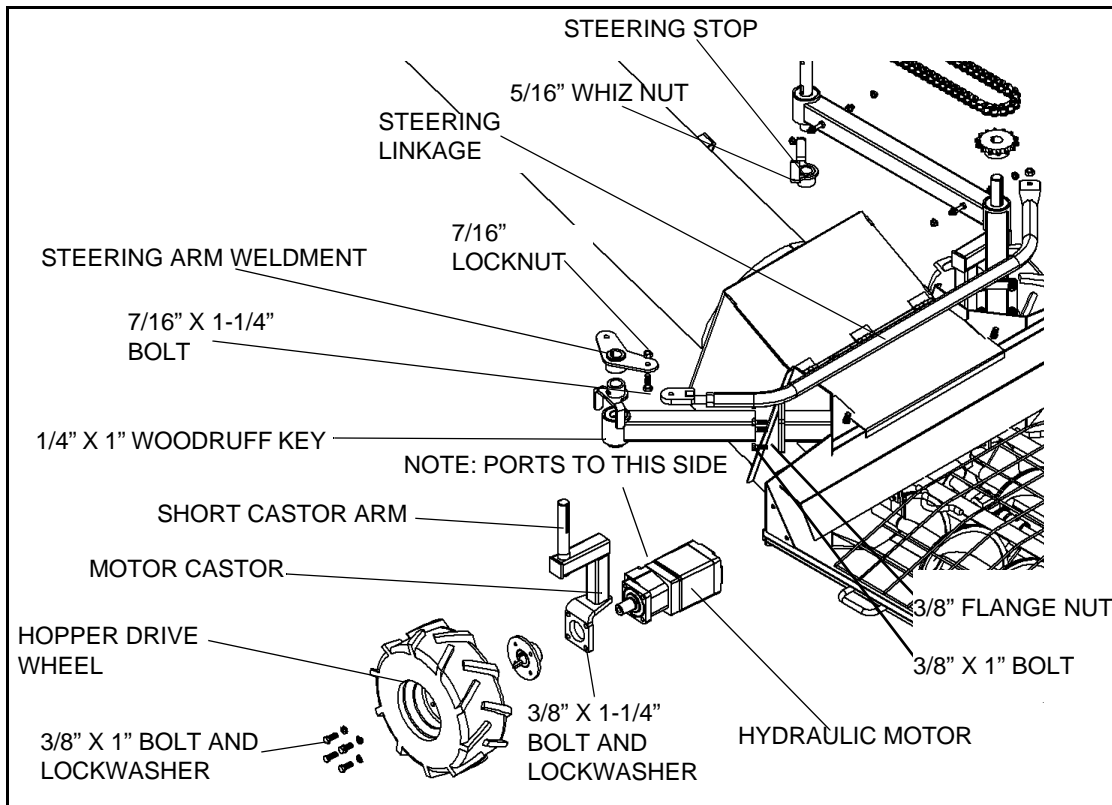

**Figure 3.54 Left Side Setup**

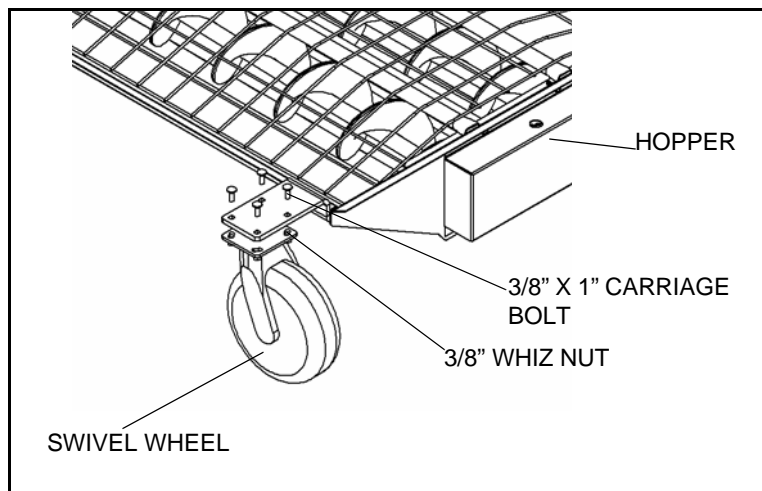

**Figure 3.55 Left Side Setup**

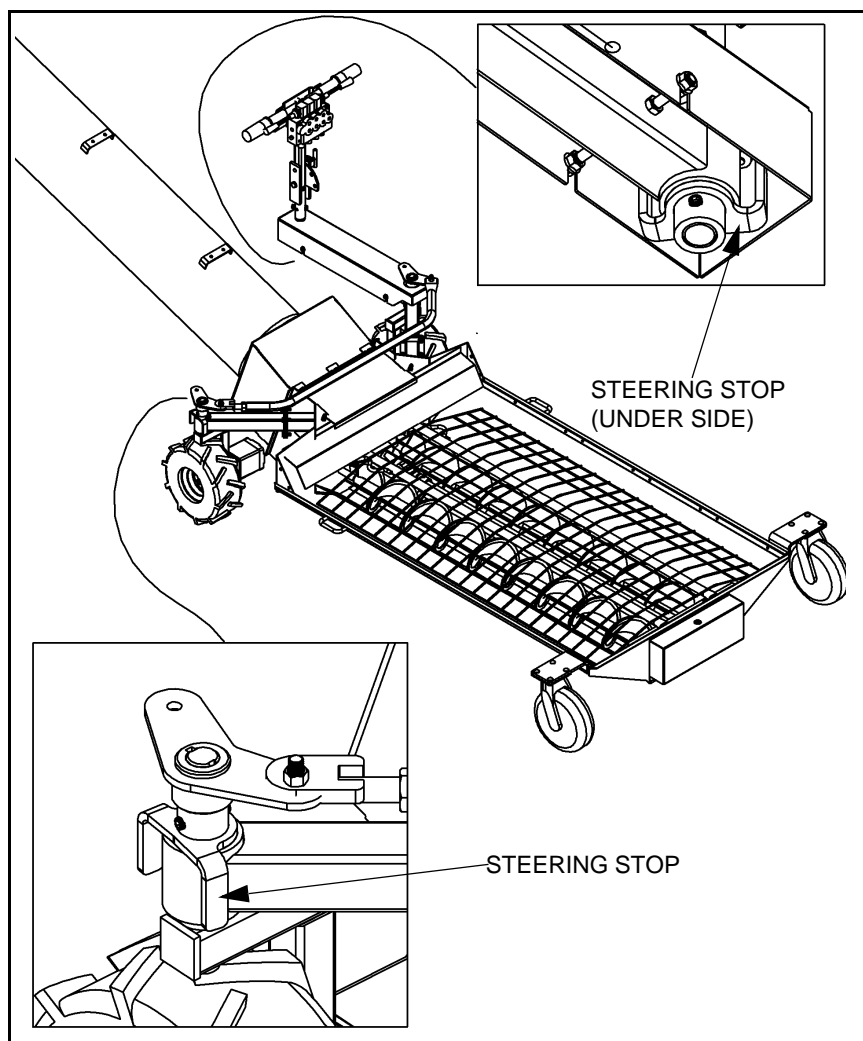

**Figure 3.56 Steering Stop Placement on Left Side Setup**

3. Insert a sprocket on the steering shaft and on motor castor on the long castor arm (on side with steering assembly). Connect sprockets with steering chain and secure with connecting link and clip.
4. Place steering cover over chain and secure in place with eight 5/16" whiz nuts (one whiz nut on each side of cover, 4 places).

5. Insert foldable handle over steering shaft; secure in place with a 3/8" x 2" bolt and 3/8" flange nut. See Figure 3.48 for right side setup or Figure 3.53 for left side setup.
6. Place steering stops on each steering shaft but do not tighten set screws until Step 13.
7. Slide steering arm weldments over motor castors, secure in place with 1/4" x 1" key. Tighten setscrews on each side.
8. Points A and B on steering arm weldments should point at main auger. See Figure 3.57 for right side set-up, and see Figure 3.58 for left side set-up.

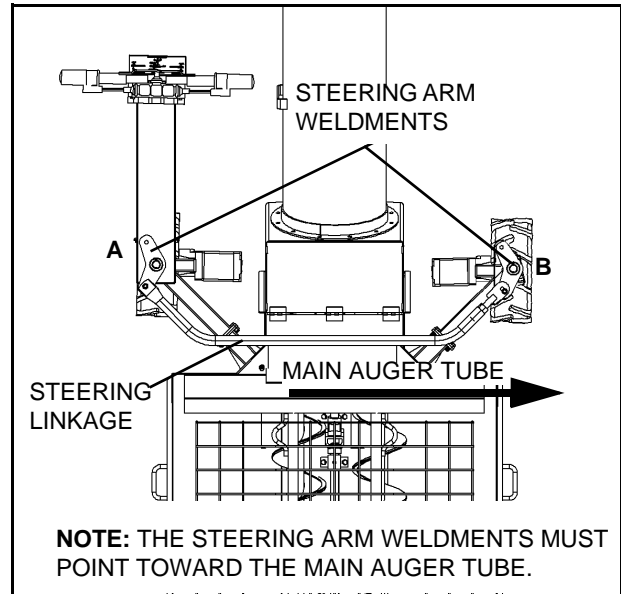

**Figure 3.57 Right Side Setup**

9. Place steering linkage on holes nearest hopper on steering arm weldments, see Figure 3.57, or Figure 3.58. Adjustment is built into steering linkage to align tires parallel to each other if required. Secure with two 7/16" x 1-1/4" bolts and two 7/16" locknuts. Nuts should be tight enough to hold linkage in place but allow it to move easily when using the steering arm.

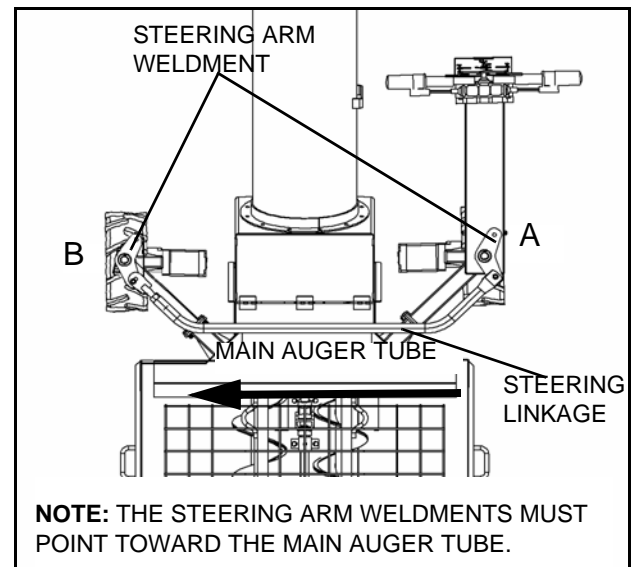

**Figure 3.58 Left Side Setup**

10. Insert hydraulic motors through motor castors and secure with 3/8" x 1-1/4" bolts and 3/8" lockwasher (4 bolts per motor). Ensure motor ports are installed towards swing spout, as shown in Figure 3.58 and 3.49. or 3.53 and 3.54.
11. Place hopper drive wheels on hydraulic motor shafts, securing in place with 1/4" Woodruff key. Tighten setscrews.
12. Install hopper drive wheel on wheel hub with four 3/8" x 1" bolts and 3/8" lockwashers.
13. Once set up for right or left side use, turn handle so that wheels are 90° to the swing tube. Adjust position of stops so that wheels cannot be turned further and tighten set screws (Figure 3.51 for right-side setup, and Figure 3.56 for left-side set-up). Continue to turn handle to ensure full 90° range.

### 3.16.2. ATTACHING SWING TO FLEX AUGER

1. Clean u-joint spline and lower gearbox spline, then apply a light film of grease on splined shaft.
2. Guide splined universal joint onto splined shaft as the intake hopper is lowered onto the boot. Once positioned, the swivel ring rests flat on the boot surface and inside the four spacer nuts.
3. Install four spout head retainers and large boot retainer spacers (galvanized) with 3/8" x 3/4" bolts to keep the intake hopper in place on the boot.
4. Lubricate the universal joint and close the safety discharge door.

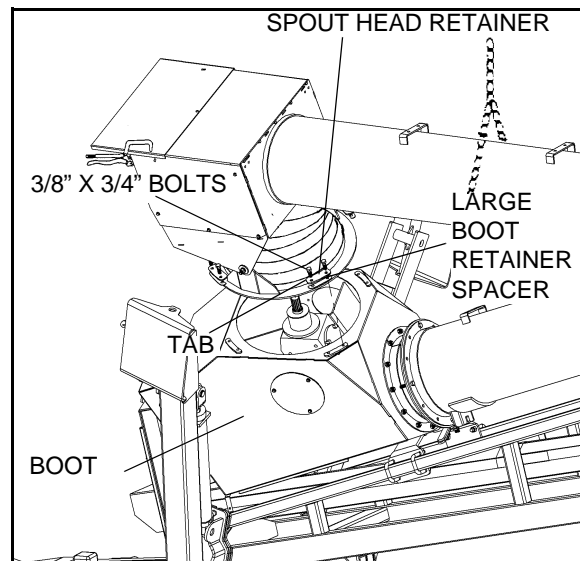

Figure 3.59

### 3.16.3. HOPPER LIFT ARM / WINCH



Figure 3.60

1. Choose either the right or left side; secure hopper lift arm assembly to the mount bracket on top of the lower auger tube with two mount pins and hairpins (Figure 3.62).
2. Attach the hydraulic winch and mount using hardware provided (Figure 3.61 and 3.62).



3. Thread cable through pulley on lift arm and wrap around the winch drum, starting at the top. Cable must have at least 3 complete wraps around the drum when intake hopper is fully lowered (Figure 3.62). Trim excess cable.

<b>WARNING</b>	
	<p><b>Falling auger hazard.</b></p> <p>To prevent serious injury or death while winching, ensure cable is fed onto the winch drum as described. Replace cable if frayed or damaged.</p>

4. Tighten all hardware.
5. Install the valve, hydraulic fittings, and mount plate (Figure 3.61 and 3.63).
6. Connect hydraulic winch hoses to the valve on the front of the auger (Figure 3.63).
7. After the hydraulic system is completed, start the system and slowly activate the hydraulic winch valve to take up the excess cable.

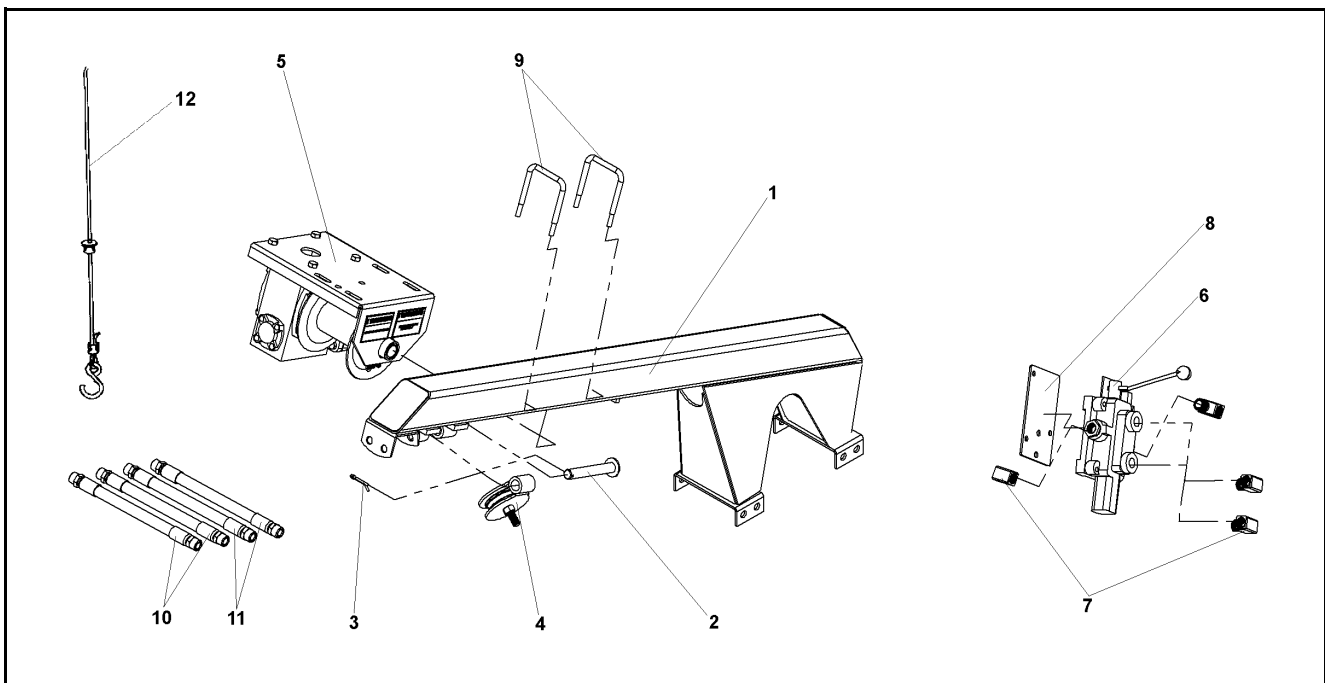

**Figure 3.61**

ITEM	PART NO.	DESCRIPTION	QTY.
1	28879	HOPPER LIFT ARM WELD'T, MK FLEX	1
2	28885	LIFT ARM SPINDLE WELD'T, MK FLEX	2
3	18155	COTTER PIN, 3/16" x 1-1/4"	2
4	28836	LIFT ARM PULLEY ASSY, MK FLEX	2

HYDRAULIC WINCH KIT ONLY			
ITEM	PART NO.	DESCRIPTION	QTY.
5	17634	HYD WINCH ASSY	1
6	17675	HYDRAULIC VALVE	1

HYDRAULIC WINCH KIT ONLY			
ITEM	PART NO.	DESCRIPTION	QTY.
7	17699	VALVE FITTINGS	4
8	28923	HYD WINCH VALVE MOUNT, MK FLEX	1
9	28833	U-BOLT SQ 3/8" NC X 3-1/16" X 4" X 1" THD GR5 PLTD	2
10	28834	3/8" X 280" HYDRAULIC HOSE	2
11	28835	3/8" X 60" HYDRAULIC HOSE	2
-	16419	HYD WINCH BOLT BAG	1
-	17376	HOPPER LIFT CABLE, 1/4" X 31'	1

8. Check the alignment of the winch by watching the cable wrapping on the drum as the swing tube is raised. Proper alignment is achieved when the cable indexes properly filling each row on the drum evenly and not piling up against one side.
9. If the cable does not index properly, lower the swing tube fully until there is slack in the cable. Loosen the bolts on the winch. Adjust the winch, retighten nuts, and retest.

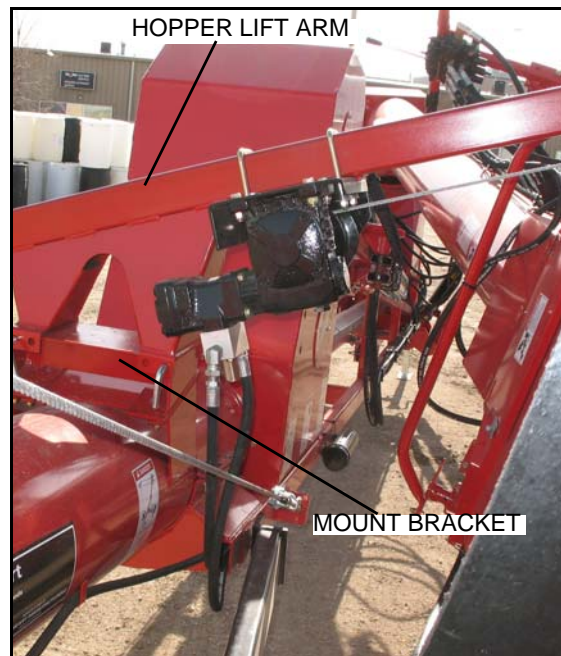

**Figure 3.62**

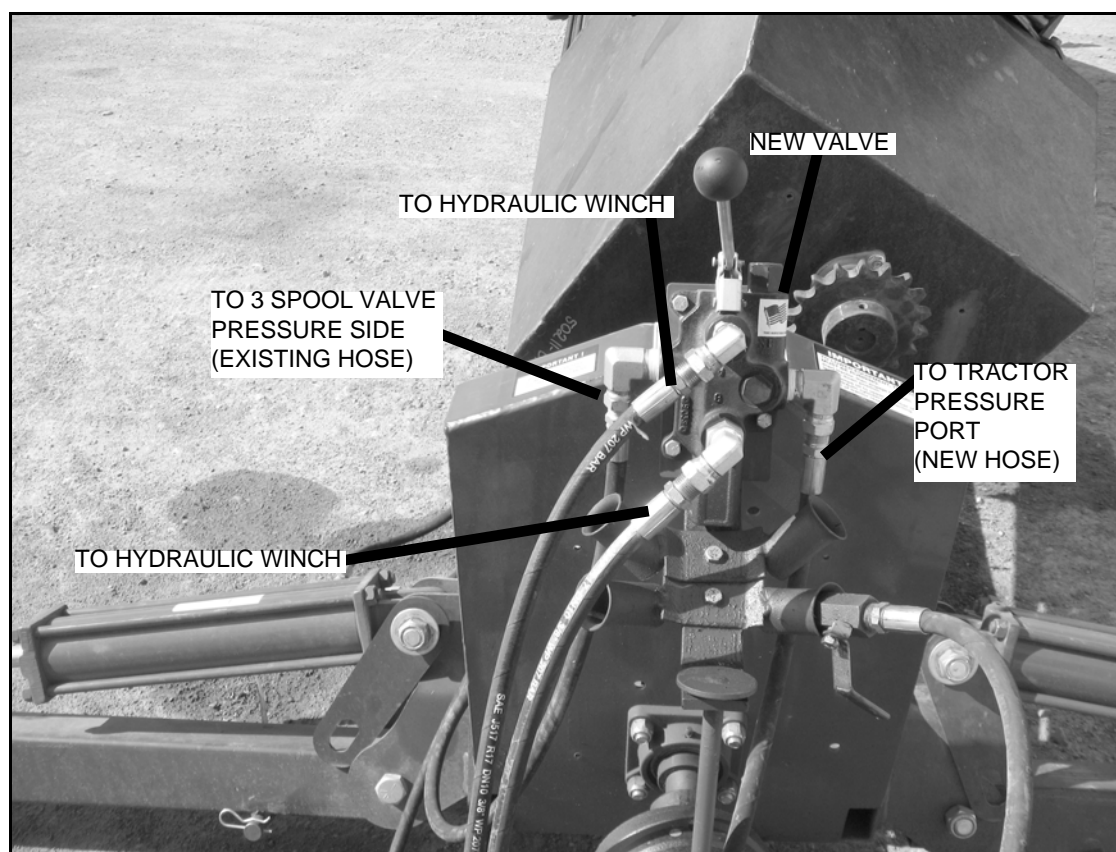

Figure 3.63

### 3.16.4. PLACING HOPPER INTO TRANSPORT POSITION

---

1. Attach cable hook to the loops inside the hopper (Figure 3.60).
2. Fully raise hopper with intake side facing towards the main auger as shown in Figure 3.60.
3. Secure hopper to lift arm with hopper lock, saddle pin, and hairpin provided.

## 3.17. FLEX AUGER HYDRAULICS

**Note:** *Hose layout is shown mounted on the right side of the auger as shown from the hopper end facing toward the spout end. Hose layout will be mirrored from lower boot to hopper if hopper mounted on left side.*

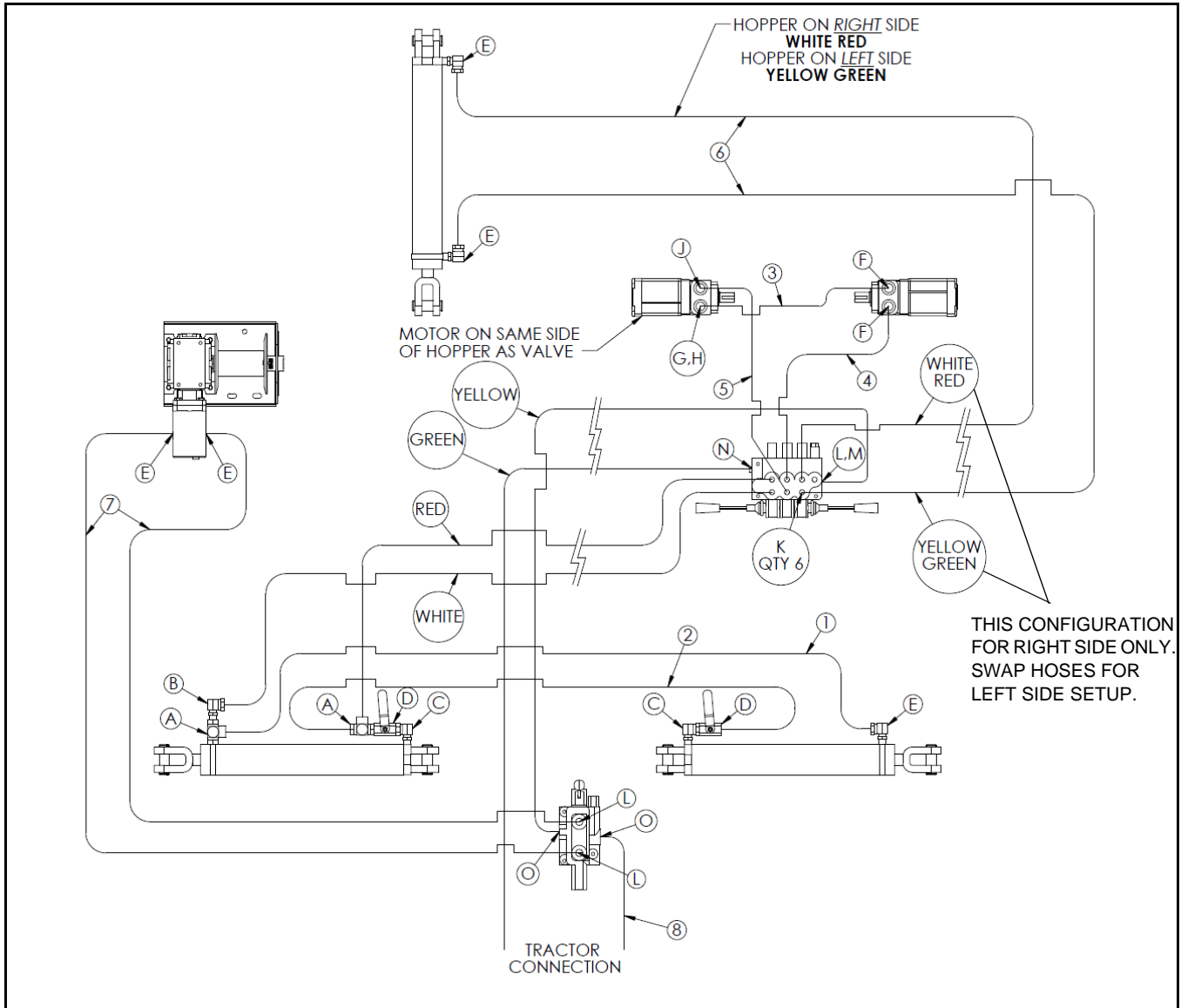

**Figure 3.64**

1. Install all hose fittings and ball valves as shown in Figure 3.64 and described in Table 3.2

**Table 3.2**

LABEL	PART NO.	DESCRIPTION
1	28751	3/8" X 88" HYDRAULIC HOSE, MK FLEX
2	28752	3/8" X 124" HYDRAULIC HOSE, MK FLEX
3	28755	3/8" X 64" HYDRAULIC HOSE, MK FLEX
4	28756	3/8" X 88" HYDRAULIC HOSE, MK FLEX
5	28754	3/8" X 52" HYDRAULIC HOSE, MK FLEX
6	29205	3/8" X 125" HYDRAULIC HOSE, MK FLEX
7	28834	3/8" X 280" HYDRAULIC HOSE, MK FLEX

LABEL	PART NO.	DESCRIPTION
A	28763	STEEL TEE, 6MNPT X 6MJIC X 6MJIC RUN
B	28762	STEEL ELBOW 90, 6MJIC X 6FJIC
C	28764	STEEL ELBOW 90, 6MNPT X 6MNPT
D	18084	3/8" BALL VALVE
E	28757	STEEL ELBOW 90, 6MNPT X 6FNPSM
F	28758	STEEL ELBOW 45, 10MORB X 8MJIC
G	28760	STEEL, 10MORB X 8MJIC

**Table 3.2**

LABEL	PART NO.	DESCRIPTION
8	28835	3/8" X 78" HYDRAULIC HOSE, MK FLEX
	29206	UPPER HOSE ASSEM, MK FLEX
	29207	LOWER HOSE ASSEM, MK FLEX

LABEL	PART NO.	DESCRIPTION
H	28761	STEEL ELBOW 90, 8MJIC X 8FJIC
J	28759	STEEL ELBOW 90, 10MORB X 8MJIC
K	28504	STEEL ELBOW 45, 6MORB X 6MJIC
L	28478	STEEL ELBOW 1/2MNPT X 1/2 FNPSM
M	28508	STEEL, 8MORB X 1/2 FNPSM X 1/16 ORIFICE
N	28654	#8 M-ORB-1/2F-NPT-90DEG FITTING
O	29087	STEEL ELBOW 90, 12MNPT X 8FNPSM

- Loosely connect hydraulic hose holders to swing and flex tubes. Note that only two hose holders are required at the top end of the flex tube (Figure 3.73). Three hose holders stacked together can hold four hoses, two hose holders stacked together can hold two hoses. Refer to Figure 3.65.

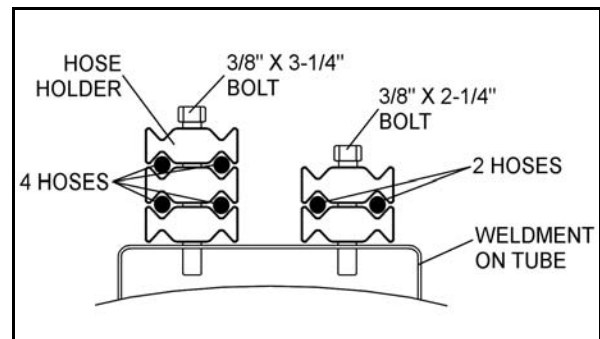

**Figure 3.65**

- Three hose holders attach to weldments with 3/8" x 3-1/2" bolts and locknuts.
  - Two hose holders attach to weldments on tubes with 3/8" x 2-1/4" bolts and locknuts.
- Loosely connect hydraulic hose holders to hold four hoses (see left side of Figure 3.65) to brackets on side of flex frame as shown in Figure 3.66.
  - Use hose bundle marked with part number 29207 (contains four hoses) and secure to flex tube as shown in Figure 3.66 with hose holders.

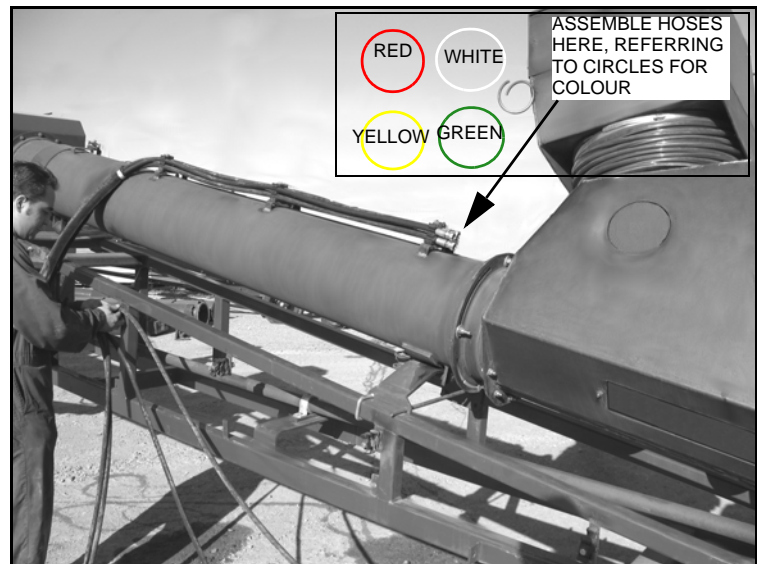

**Figure 3.66**

- Continue to run hoses up flex tube and down flex frame and secure to hose holders as shown in Figure 3.67. Leave 6" (15.2 cm) between the hose sleeve and plastic clamps. Assemble hoses into clamp as on top so that the colors match the same stacking pattern as shown in Figure 3.66.

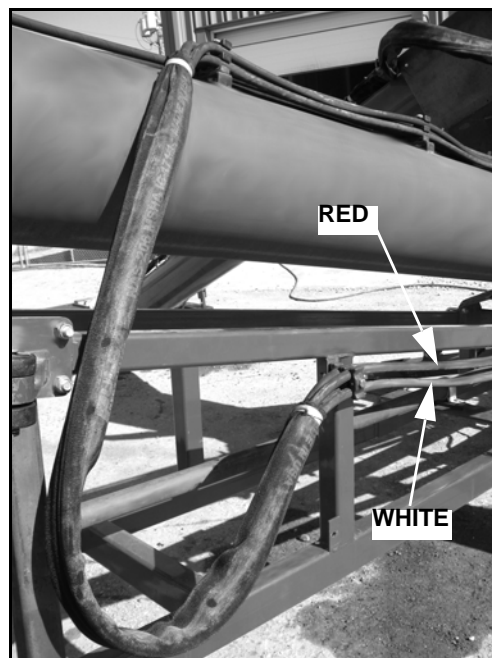

Figure 3.67

- Connect outriggers with hoses (1) and (2) as shown in Figure 3.64. Refer to Table 3.2 for hose part numbers.
- Connect hose ends to outrigger cylinder as shown in Figure 3.68.

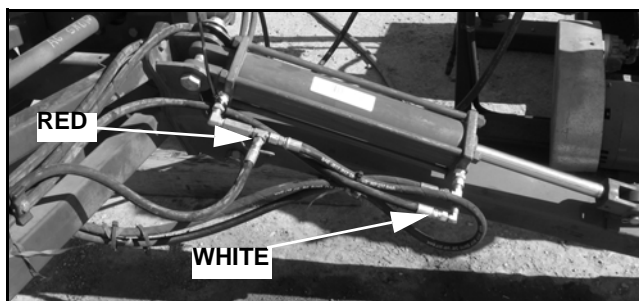

Figure 3.68

- Connect other two hoses to hydraulic winch valve as shown in Figure 3.69. Connect green end as shown. Yellow end receives the farmer-supplied pioneer coupler to connect to the tractor.

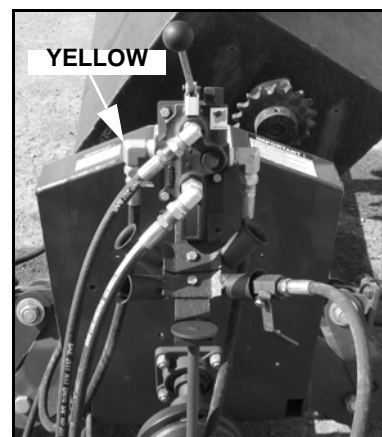
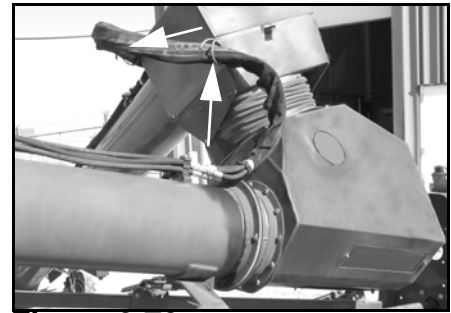

Figure 3.69

9. Install two hose rings on swing tube spout with 5/16" X 3/4" bolts and 5/16" whiznuts as indicated by arrows in Figure 3.70.
10. Use hose bundle marked with 29206 (contains six hoses) and connect to hoses installed on flex tube. Make sure to match hose colors to each other and route hoses through hose ring on spout as shown in Figure 3.66.



**Figure 3.70**

11. Lay hoses on top of swing tube and secure in place with five sets of hose holders as shown in Figure 3.71.
12. Connect hoses on swing tube to three spool valve. Refer to Figure 3.64, which shows how to connect the hoses and which colors go to each port.

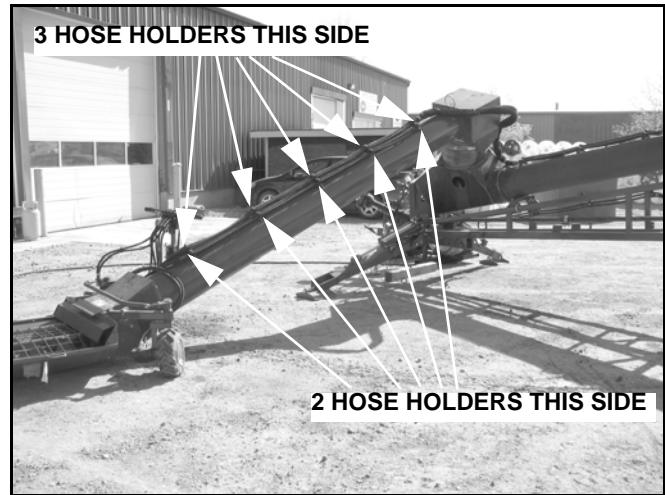

**Figure 3.71**

13. Use hoses labelled 29205 and connect to the remaining hose ends on the lower flex tube as shown in Figure 3.72 and 3.64. Secure hoses to flex tube with hose holders as shown in Figure 3.72.



**Figure 3.72**

14. Secure other ends of hoses to flex tube cylinder as shown in Figure 3.73 and secure with zip ties.
15. Connect shortest set of hydraulic hoses to 3 spool valve and to hydraulic motors on swing mover as shown in Figure 3.64 (see also Table 3.2). Use third hose (3) to connect the two hydraulic motors. Tie hoses together using zip ties.
16. Connect hose # 28754 to upper center valve port and to top motor port on the valve side of the hopper. Connect lower port to upper port of far side motor, using hose # 28755. Connect remaining lower motor port and lower center valve port using hose # 28756. Use zip ties to hold hoses together.
17. Connect hoses (7) from valve to hopper lift arm winch (Figure 3.64).

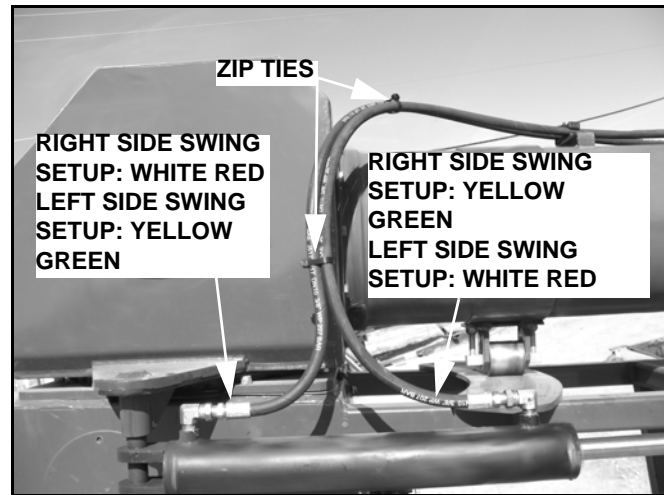

Figure 3.73

### 3.17.1. OPEN-TO-CLOSED-CENTER CONVERSION

The Flex Auger three spool valve is an open-center system and can be converted to a closed-center system, if desired. To convert:

1. Relieve pressure on the hydraulic system.
2. Using a 5/16 hex wrench, remove existing 5/8" long plug, see Figure 3.74, on the return side of the valve and replace with a 1" long plug supplied with the valve.

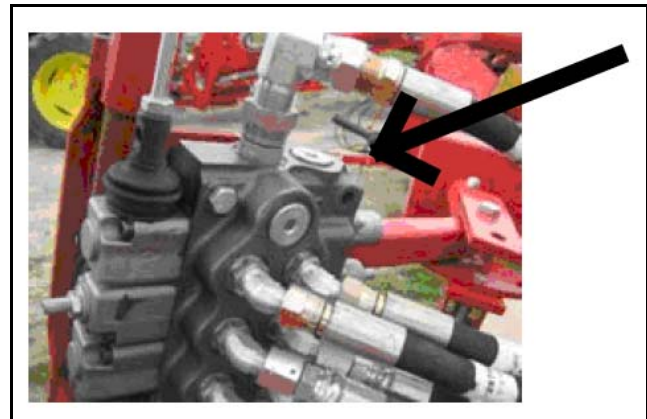

Figure 3.74



## 3.18. HITCH JACK

The jack is attached to the auger with a pin at the pivot point. To install:

1. Elevate the auger boot (intake end) approximately 2' (61.0 cm) with a front-end loader and sling, and install the jack in a vertical position. Secure it with the supplied pin.
2. Place a board beneath the jack before setting it on the ground, then lower the auger until the jack is seated. Remove front-end loader from auger.

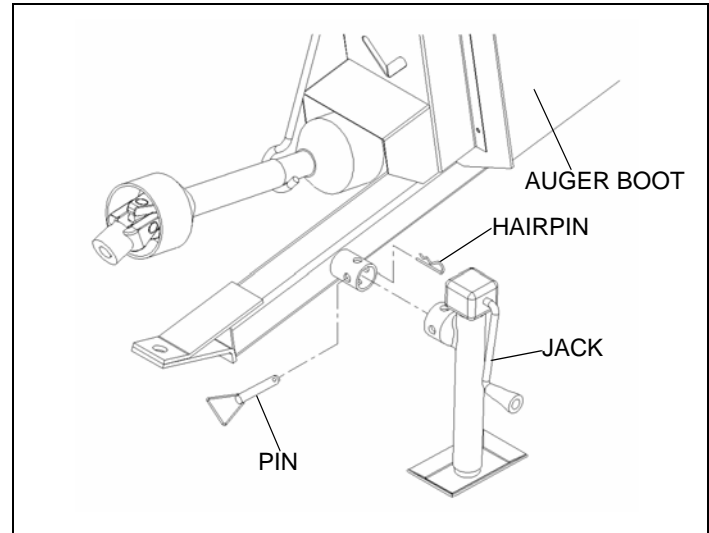



Figure 3.75

**Note:** Jack can be rotated 90° for transport or operation.

WARNING	
	<p>Jack is designed for raising or lowering auger hitch only.</p> <p>Do not get on or beneath auger while supported by, or while jack is being operated.</p>

## 3.19. AUGER-TO-TRACTOR HOOKUP

**Important:** Auger must be hooked up to tractor for all operations including transport, raising, placement, and augering grain.

### 3.19.1. PTO DRIVELINE / DRAWBAR

The final stage of the assembly is attaching the auger to the tractor.

#### HITCH PIN

When attaching the auger to your tractor, you must leave space between the bottom of the tractor drawbar and the top of the securing device on the hitch pin.

- The securing device could be 2 nuts locked against each other or a washer and sturdy hairpin.
- The space should be about 3/4" (1.91 cm) to 1" (2.54 cm) as shown.

Since the auger and tractor become an integral unit during transport, placement, and operation, the configuration and measurements between the tractor drawbar and the tractor PTO driveline are very important.

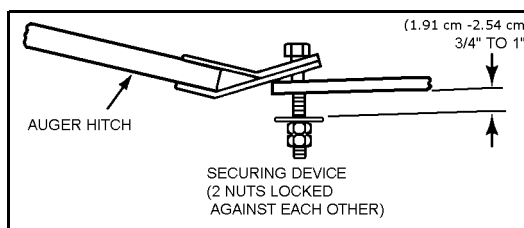

**Figure 3.76**

Figure 3.77 illustrates the ideal measurements. Most tractors fall into this range.

- Dimension (B) may range from 8" (20.3 cm) to 10" (25.4 cm) with 9" (22.9 cm) being ideal.
- If dimensions (A) and (B) on your tractor are as shown, then dimension (C), which is critical, will be correct.
- If (A) and (B) vary on your tractor from the recommended dimensions, consult the table for potential problems and their solutions.

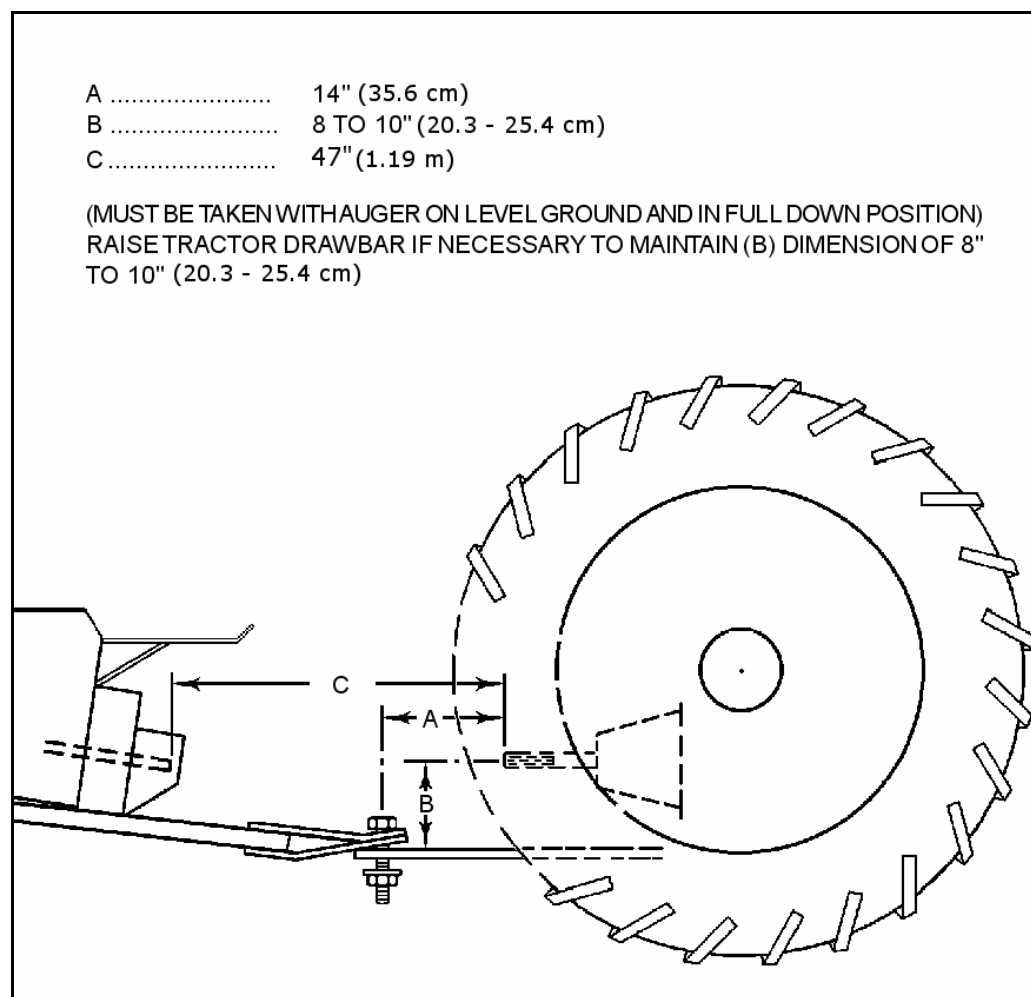

**Figure 3.77**

MEASUREMENT	PROBLEM	SOLUTION
If (A) is less than 14" (35.6 cm) (C) will be less than the recommended measurement	<ul style="list-style-type: none"> <li>The PTO driveline will bottom out when auger is in raised position.                             <ul style="list-style-type: none"> <li>This will cause damage to the PTO driveline, the bearing, or the boot housing.</li> </ul> </li> </ul>	<ul style="list-style-type: none"> <li>Pull out or lengthen the tractor drawbar as needed to make (C) the correct measurement when the auger is in full down position.</li> </ul>
If (A) is more than 14" (35.6 cm) (C) may be more than the recommended measurement	<ul style="list-style-type: none"> <li>The PTO driveline will separate from the auger in the lowered position.                             <ul style="list-style-type: none"> <li>This will cause damage to equipment and/or injury to personnel.</li> </ul> </li> </ul>	<ul style="list-style-type: none"> <li>Shorten distance (C) to the recommended measurement by attaching hitch to tractor drawbar at a point closer to the tractor PTO shaft.</li> </ul>
If (B) is more than 10" ( 25.4 cm) (C) (between tractor PTO shaft and auger input shaft) shortens more quickly when auger is being raised	<ul style="list-style-type: none"> <li>The u-joint angle on the PTO driveline will be too severe in the raised position.</li> <li>The PTO driveline will bottom out before auger is fully raised.                             <ul style="list-style-type: none"> <li>This will cause damage to the PTO driveline, flight shaft, bearing, and boot.</li> </ul> </li> </ul>	<ul style="list-style-type: none"> <li>Raise the tractor drawbar until dimension (B) is within the recommended 8" (20.3 cm) to 10" (25.4 cm).</li> </ul>

### 3.19.2. HYDRAULIC HOSE COUPLERS

Check in your tractor manual or with your dealer regarding the correct type of coupler to use on your auger. Make sure hose ends are free of dirt before securing to coupler.

### 3.20. PLASTIC MANUAL HOLDER

1. Attach holder to the lower frame arms. Manual holder must be accessible at all times, whether frame is up or down.
2. The manual holder's cap must face up (towards the intake end). Attach manual holder with supplied zip ties. Tighten the zip ties, securing the holder in place.

**Note:** *Where possible, attach the zip ties around a frame brace tab to prevent the manual holder from slipping down the lower frame arms.*

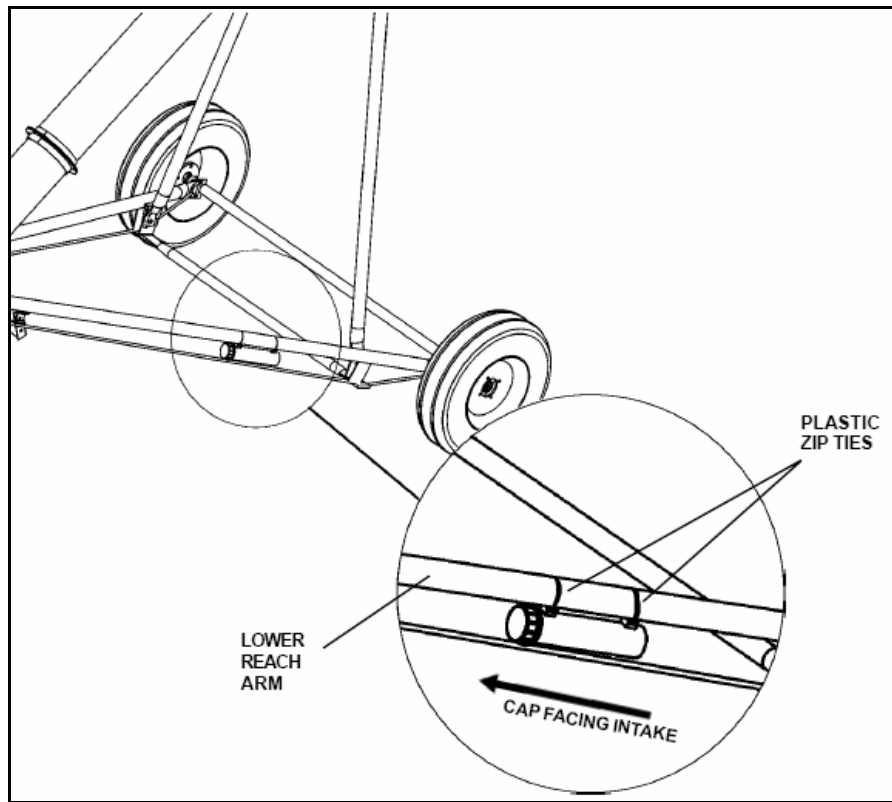

**Figure 3.78**

## 3.21. MODEL DECAL PLACEMENT

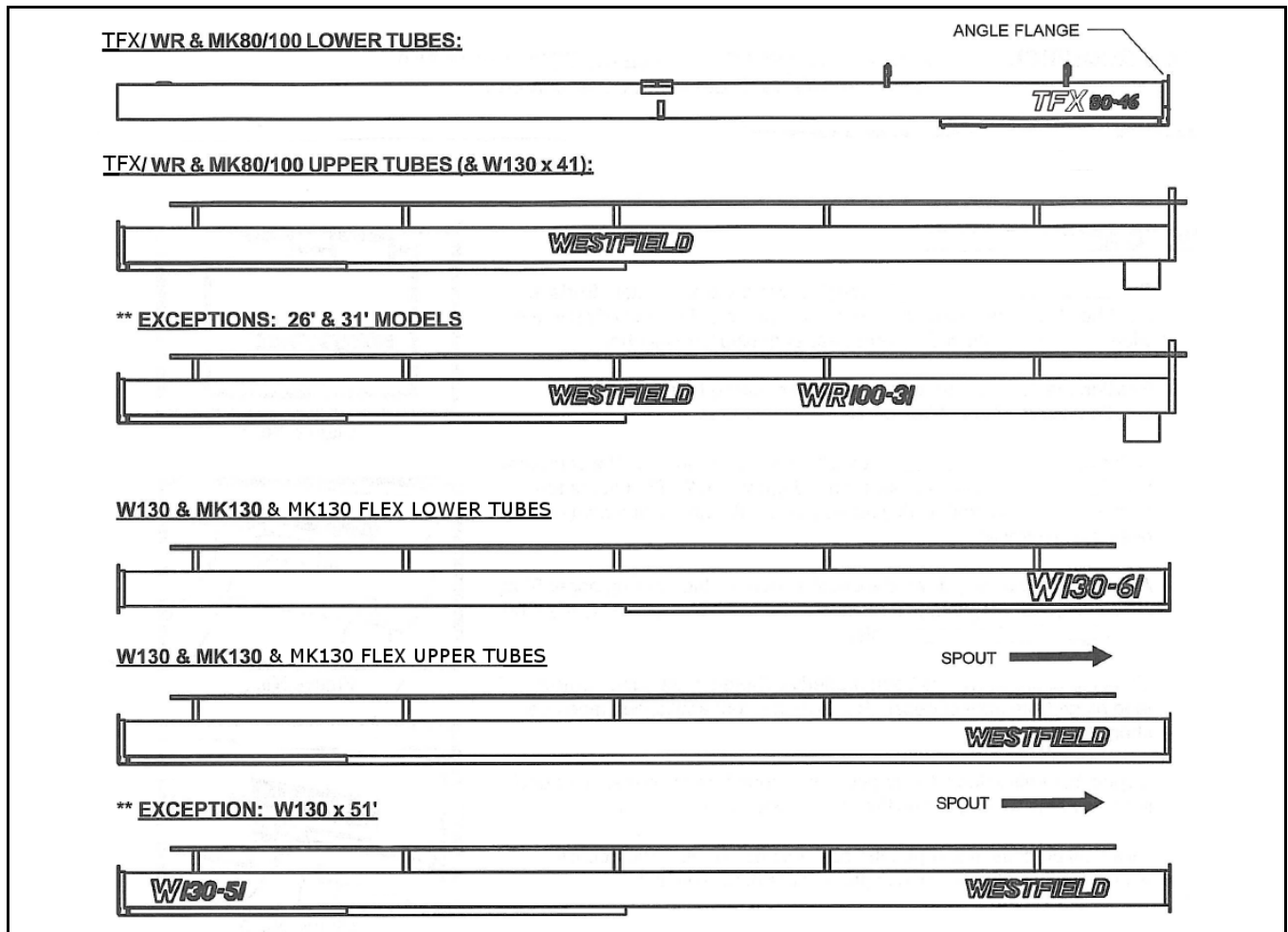

Figure 3.79

**Important:** Do not cover any existing safety or instruction decals with the model decals.

For most decal placement, follow the figure above. Apply decals to both sides of auger tube.

**Lower Tubes:** Place decals just below the angle flange, centered on the tube. Decals must be easily seen from the ground when auger assembly is complete. (For 36' augers, the model decal can be located in the center of the lower tube.)

**Upper Tubes:** Place Westfield decals in the center of the upper tube, where they are easily seen from the ground when auger assembly is complete. For the W130 & MK130 series, the Westfield decal is located at the top end of the upper middle tube.



# 4. Transport & Placement

**WARNING** Before continuing, ensure you have read and understand the relevant information in the safety section. Safety information is provided to help prevent serious injury, death, or property damage.

This auger is designed to be transported and operated without unhitching unit from tractor.

## 4.1. TRANSPORT PROCEDURE

1. Ensure auger is in full down-position with PTO driveline disconnected from tractor; see Figure 4.1. The trackshoe must be seated against the trackstop with slight tension on the lift cable, See "Lowering Auger" on page 92.

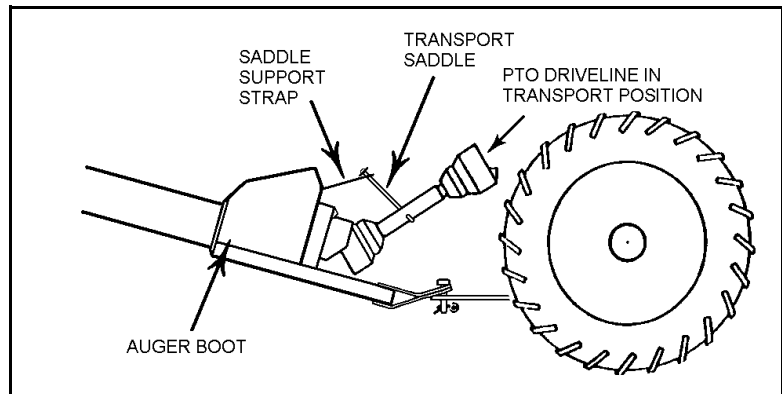

Figure 4.1

### NOTICE

If PTO is not disconnected, driveline will bottom out, severely damaging the CV u-joint end lower flight shaft. See manual for maintenance.

2. Position and secure hitch pin and safety chain. Place safety chain through clevis welded to auger hitch tube and bolt together before attaching to tractor. Refer to Figure 4.2.

**Important:** Use a type of hitch pin that will not allow auger to separate from towing vehicle.

3. Check that the flex tube is locked in place with the over-centre lock (Figure 4.4).

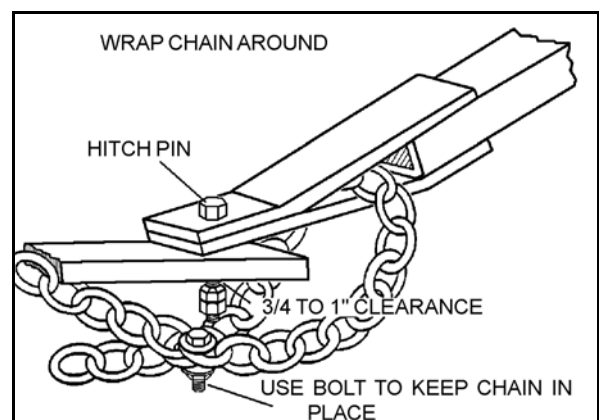

Figure 4.2

4. Ensure intake feed hopper is raised into transport position (see “Lowering Auger” on page 92) and lift cable is connected and secured with saddle pin and hairpin (see Figure 4.3).
5. Ensure outrigger legs are raised and locked in transport position. See Figure 4.4.

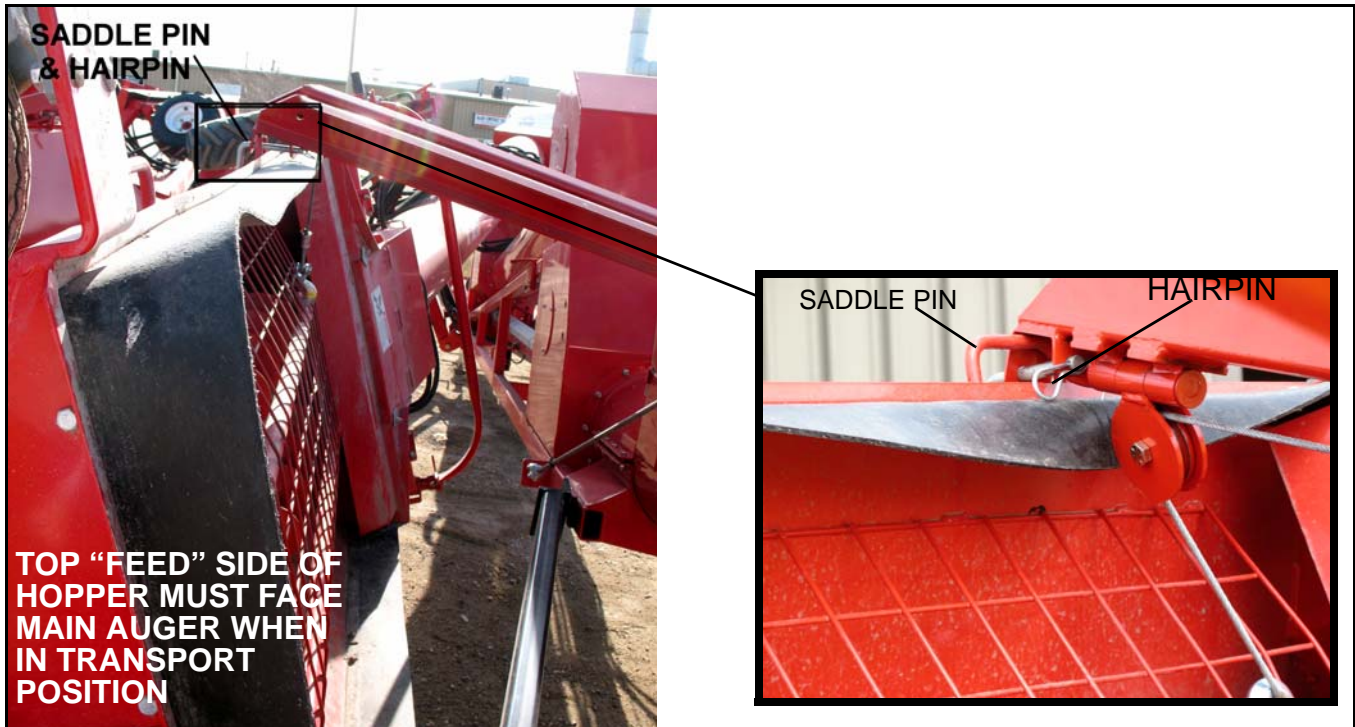

Figure 4.3

6. Place the swivel jack (on side of hitch) in transport position and lock.

### NOTICE

Do not operate auger with intake hopper in transport position. This will damage the u-joint.

7. Ensure extendable axles (if equipped) are in transport configuration. Refer to “Axle Extension Procedure (81’/91’/111’)” on page 84.
8. Beware of overhead obstructions and electrical wires and devices. The 71’ augers require minimum clearances of 12’ (3.66 m), the 81’ augers require 10’7” (3.23 m), the 91’ augers require 12’6” (3.81 m), and the 111’ augers require a minimum clearance of 15’ (4.57 m).
9. Refer to “Transport & Placement Safety” on page 12 for important safety information before towing.

### CAUTION



If auger wheels are partially or fully buried in snow or grain, failure to clear the area around the wheel before moving may cause damage to the auger or result in serious injury.



## 4.2. PLACEMENT PROCEDURE

---

1. Ensure PTO driveline is disconnected from tractor and secured in the transport saddle.

### NOTICE

When positioning, PTO driveline must be disconnected from the tractor and placed in the transport saddle to prevent damage to auger and PTO driveline.

2. Ensure towing hitch is in place and secure.

**Important:** Use a type of hitch pin (see Figure 4.2) that will not allow the auger to separate from the towing vehicle.

3. Ensure the auger is on reasonably level ground when raising, lowering, or when positioning.
4. Before raising or positioning auger, make sure that entire area in line of travel, both on the ground and overhead, is clear of any obstructions or electrical wires.

### NOTICE

To prevent equipment damage, hydraulically lift the outriggers before raising or lowering the auger.

### CAUTION



If auger wheels are partially or fully buried in snow or grain, failure to clear the area around the wheels before moving may cause damage to the auger or result in serious injury.

**Important:** Because of the many different kinds of tractor hydraulic systems, the quick-connect coupler must be supplied by the owner. Please consult your tractor manual or dealer for the proper coupler.

5. Before connecting the auger and tractor hoses, wipe off the quick-connect couplers.

### NOTICE

Dirt in the hydraulic system can damage the cylinder o-rings, causing leakage and the possible failure of the system and personal injury.

6. Connect hydraulic hoses tightly. Check for leaks, binding, flattening, kinks, or wear.
7. If the auger must be raised for positioning:
  - a. Check that the valve on the hose to the lift cylinder is open.

- b. Check that the area above and around the auger is clear.
- c. Raise auger to the desired height using tractor hydraulic controls.

**Note:** *Wheels must be free to move when raising or lowering auger.*

- d. Close hose valve after auger is positioned.

WARNING	
	Auger must be hooked up to tractor for all operations, including transport, raising, placement, and augering grain.

**Important:** *The hydraulic cylinders are shipped without oil and must be charged with oil before auger is put into operation for the first time. See the "Lift Cylinder Hydraulics (81'/91'/111')"* on page 104 for charging instructions.

WARNING	
	Fluid leaks in the hydraulic cylinder or hose will allow auger to lower inadvertently. Repair all leaks and breaks immediately.

CAUTION	
	If hose valve remains open, a loss of hydraulic pressure within the tractor system will allow the auger to lower inadvertently, damaging equipment and/or causing personal injury.

- 8. Move the auger into working position slowly. Do not unhitch and attempt to move auger by hand.

WARNING	
	Never attempt to increase height of auger by positioning wheels on lumber, blocks, or by any other means. To do so will result in damage to equipment and/or serious injury.

NOTICE	
When positioning the auger, the PTO driveline must be disconnected from the tractor and placed in the transport saddle to prevent damage to auger and PTO driveline.	

9. Once auger is in position, chock wheels on both sides and apply the park brake on the tractor (or chock its wheels as well) to prevent movement during operation.
10. Connect and secure the main hydraulic lines to the tractor.

**Important:** *If your tractor is equipped with a single hydraulic system, relieve pressure and disconnect lift hose to connect main hydraulic system hoses. Do not disconnect the hydraulic couplers when under pressure. Refer also to the tractor manual.*

WARNING	
	Escaping hydraulic fluid under pressure can cause serious injury if it penetrates the skin. Wear protective clothing when working around hydraulic equipment.

11. Clear hydraulic hoses away from any moving parts.
12. Engage tractor hydraulics and remove retaining pins and locks. Lower outrigger legs using hydraulic controls located on the flex hopper. Close ball valves located on outrigger legs to secure once fully lowered (Figure 4.4).

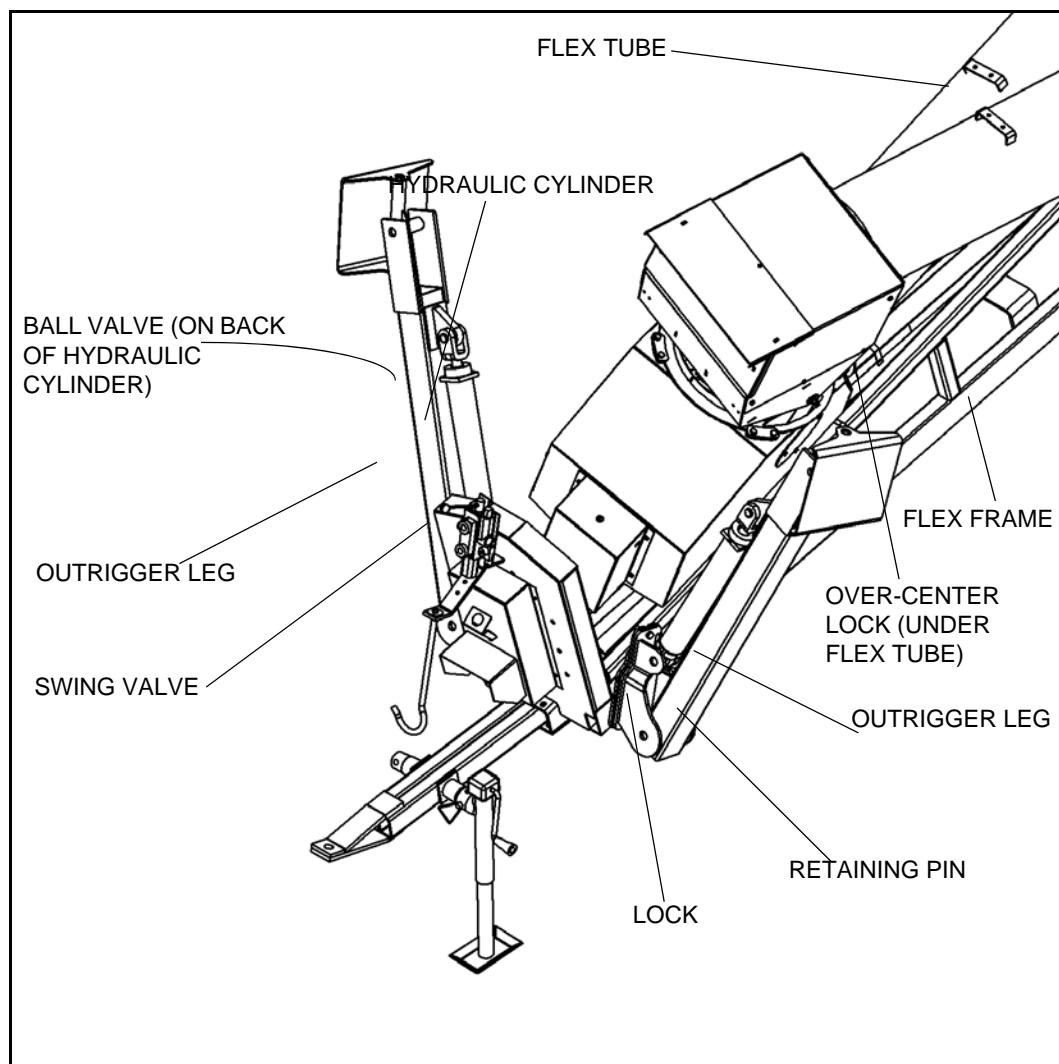

**Figure 4.4**

13. Remove the saddle pin and hairpin holding the swing hopper in place, see Figure 4.4.
14. Using the hydraulic winch control valve, fully lower the swing hopper to the ground and remove lift cable.
15. Under the flex tube boot, move the over-center lock to lock/unlock, this allows the flex tube to move during operation (Figure 4.4).

WARNING	
	Do not use auger as a hoist to raise any object regardless of weight. Doing so could result in serious injury, death, or damage to the auger or item being lifted.

### 4.2.1. AXLE EXTENSION PROCEDURE (81'/91'/111')

Place auger on level ground before attempting to extend or retract the axle extensions. **Auger must be attached to tractor at all times.**

Once the auger is in place, you may begin the axle extension process.

1. Using the jack supplied, insert it into one of the jack lugs located on one end of the axle (Figure 4.5). Jack must be secured to jack lug using pin (attached to jack).
2. Raise one side at a time. Ensure that the jack is vertical. Turn the crank to start raising the jack. Raise one side of the axle until the tire clears the ground.
3. Remove the axle pin from the axle and slide the axle outwards 16" (40.6 cm) until the second set of holes line up (Figure 4.5). Reinsert the pin and secure with snap pin. Lower the jack.

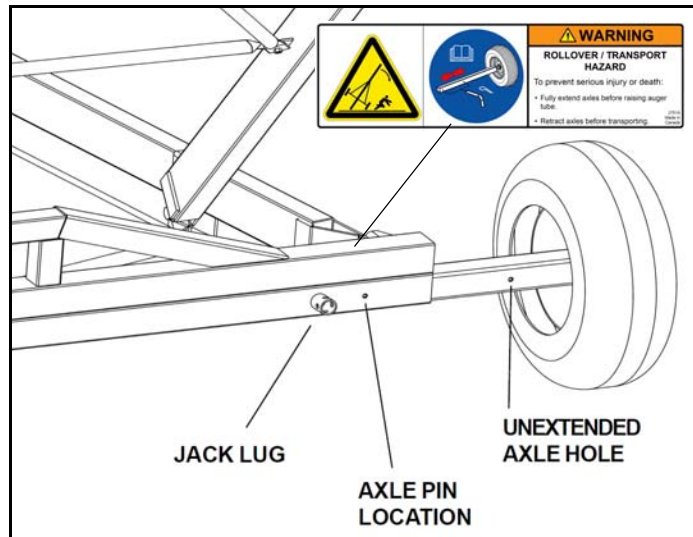



Figure 4.5

WARNING	
	Do not raise the auger unless the axles are in the extended position. Do not transport the auger unless the axles are in the retracted position.

4. Repeat the process on the other side of the axle to extend the other side.

**Note:** *Use the same procedure, in reverse, to retract the axle.*



# 5. Operation

**WARNING** Before continuing, ensure you have read and understand the relevant information in the safety section. Safety information is provided to help prevent serious injury, death, or property damage.

## 5.1. PRE-OPERATIONAL CHECKLIST

Operators must observe safety procedures at all times and follow the pre-operational checklist before each start-up.

Before operating auger each time, the operator must confirm the following:

- All fasteners are secure as per assembly instructions.
- Cable clamps are secure.
- Lift cable is not frayed or damaged.
- Lift cable is properly seated in cable sheaves.
- Hydraulic hoses are in good condition.
- Hydraulic connections are in place and secure.
- PTO driveline is connected and secure.
- PTO driveline shield rotates freely.
- Clean-out door, service door and access covers are in place and secure and safety discharge door is closed.
- All safety guards are in place and secure.
- Tube alignment is reasonably straight.
- Intake area and discharge spout are free of obstructions.
- Auger wheels are chocked, and if necessary, tractor wheels are chocked or the parking brake has been engaged.
- Proper maintenance has been performed.
- Tractor and auger are in line or as close to being in line as possible.
- Over center lock under main boot is released to allow it to move during operation.
- Know how to safely shut down the auger in an emergency.

## 5.2. AUGER DRIVE & LOCKOUT

**Note:** If shearbolt in PTO driveline fails, shut down and lock out tractor to replace bolt.

The Flex uses two 3/8" x 1" grade 5 bolts through the thread shear.

3/8" x 1" GR5 Bolt part number is 18955.  
3/8" Nylon Locknut part number is 17402.

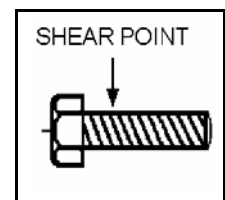

Drive Type	Before Operation	Lockout
PTO Driveline	<p>Before starting, ensure</p> <ul style="list-style-type: none"> <li>• PTO driveline is securely attached to the tractor and flight shaft</li> <li>• tractor park brake is engaged and/or wheels are chocked</li> <li>• you are not exceeding the maximum operating length of 47" of the PTO driveline</li> <li>• PTO drive on the tractor is in the off position</li> </ul>	<p>Shut off tractor's engine and remove key or coil wire from tractor.</p> <ul style="list-style-type: none"> <li>• If removing key is impossible, remove PTO driveline from tractor.</li> </ul>

## 5.3. OPERATING PROCEDURE

### 5.3.1. START-UP & BREAK-IN

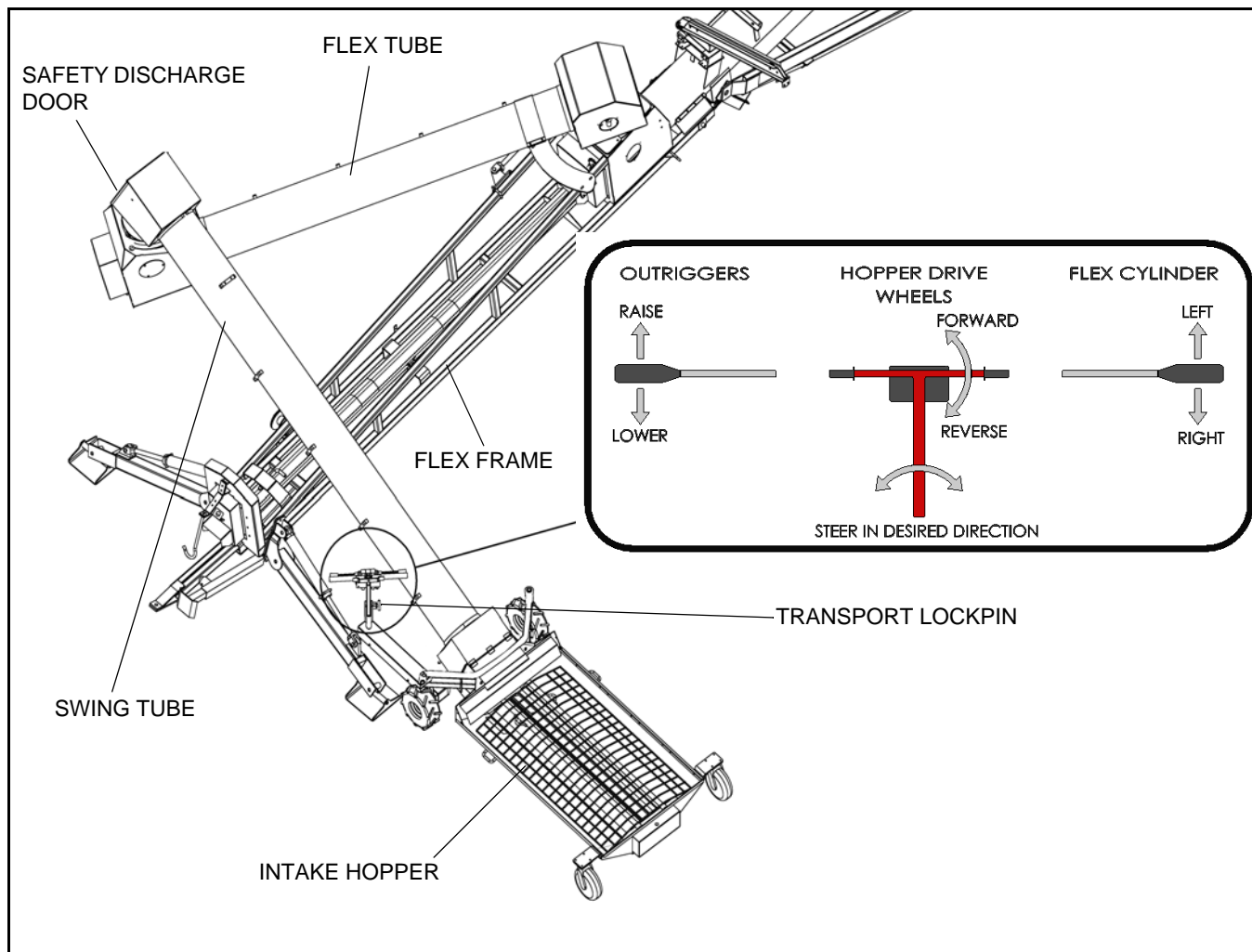

Figure 5.1



## CAUTION



Auger must be hooked up to tractor for all operations, including transport, raising, placement, and augering of grain.

1. Ensure auger is properly placed and complete the pre-operational checklist. If everything is satisfactory, prepare for one hour of operation at half speed.

## NOTICE

To prevent equipment damage, lower the outriggers before operating the auger.

**Important:** *Do not operate auger with intake hopper in transport position. This will damage the u-joint.*

2. Using the hydraulic controls, position the intake hopper as shown in Figure 5.1.

**Note:** *Use the hopper drive wheel and flex cylinder at the same time to position the flex tube.*

**Important:** *When starting auger for the first time, be prepared for an emergency shutdown in case of excessive vibration or noise. Auger may run rough until tube is polished.*

3. Roughly position the truck trailer centered at the intake hopper and use the hydraulic controls to position the intake hopper under the truck hopper.
4. Start tractor and idle at low rpm. Slowly engage PTO drive.
5. Gradually begin feeding grain into intake hopper, bringing auger speed up to about 300 rpm. Do not overfeed intake hopper on initial loads; keep feed of grain at about half capacity.
6. Once one truck hopper is empty, use the hydraulic controls to move the hopper under the remaining hopper and continue unloading truck.

## NOTICE

Running auger empty at high speeds results in excessive wear. Do not exceed 540 rpm.

7. After auger tube is polished and runs fairly smoothly, proceed to unload at full speed of 540 rpm.
8. After initial run, slow auger down until empty of grain and then stop.
9. Lock out tractor and conduct a complete inspection of auger following the checklist (see "Pre-Operational Checklist" on page 87).

After initial start-up and inspection, auger should be inspected at least 3 more times during the first 10 hours of operation.

**After Break-in:** Maintain auger speed of 300 to 540 rpm under normal use for maximum efficiency and to reduce the chance of plugging.

Once auger is broken in, the checklist should be a part of the daily routine before operating auger.

### 5.3.2. OPERATING WITH A FULL LOAD

---

1. When operating the auger, always work with a second person in a position to monitor the operation and initiate a shutdown in case of emergency.
2. Monitor the auger during operation for abnormal noises or vibrations.
3. Shut off all power before making adjustments, servicing, or cleaning the machine.
4. If grain overflows through safety discharge door, then the auger is loaded beyond its capacity; reduce volume of feed to intake hopper. Remember, auger capacity will decrease at steeper angles of operation.
5. Engage and disengage PTO drive with tractor engine at idle speed. This will reduce stress on drive components and on shear bolts.
6. Do not exceed 540 rpm on the PTO.

<b>DANGER</b>	
	<p><b>Rotating Flighting Hazard!</b></p> <p>To prevent death or serious injury:</p> <ul style="list-style-type: none"><li>• Keep away from rotating auger flighting.</li><li>• Do not remove or modify auger flighting guards, doors, or covers. Keep in good working order. Have replaced if damaged.</li><li>• Do not operate the auger without all guards, doors, and covers in place.</li><li>• Never touch the auger flighting. Use a stick or other tool to remove an obstruction or clean out.</li><li>• Shut off and lock out power to adjust, service, or clean.</li></ul>

**USE OF GRAIN SPREADERS:** Many grain spreaders cannot handle the large capacity of some augers. Some augers plug, causing damage to the flighting and other drive components. This type of damage is not covered by warranty. Hints on how to avoid this...

- Get a larger spreader, if available.
- Remove the spreader.
- Make sure spreader is turned on.
- Center auger spout on spreader.
- Do not lower auger spout into spreader.
- Suspend the spreader from bin ceiling leaving extra room for excess grain to flow over the spreader.

**BIN LEVEL INDICATORS:** These augers are fast and bins fill up quickly. A full bin will cause auger to plug, which can damage the flighting and other drive components. Installing quality grain-level indicators on your bins will allow you to monitor bin filling and help prevent damage to your auger.

### 5.3.3. SHUTDOWN

---

#### NORMAL SHUTDOWN

1. Near the end of a load, decrease auger speed until all grain is clear of machine.
2. When auger is clear of grain, disengage PTO drive.
3. Shut down and lock out tractor.

#### EMERGENCY SHUTDOWN / FULL-TUBE RESTART

1. If cleanout covers or safety doors have been opened or removed, close or replace them before restarting the unit.

#### NOTICE

Starting the auger when there is grain blockage will result in damage to the auger.

2. If the auger is shut down for an emergency, lock out tractor before correcting the problem.
  - If the problem is plugging, clear as much of the grain as possible using a piece of wood, wet/dry vac, or other tool before restarting auger. **Do not reach in and use your hands** even if the tractor has been locked out.
3. If auger tube is full of grain, do not restart at full speed. Engage PTO at low rpm, gradually increasing power until normal operating speed is reached.

## 5.3.4. LOWERING AUGER

---

After operation, move auger to next work/storage area and clean out.

1. Clean entire work area.
2. Disconnect PTO driveline from tractor.
3. Place flex tube in transport position, lock in place with over center lock on flex frame (see Figure 5.3).
4. Use hydraulic valve to raise intake feed hopper slightly.
5. Remove all supports and chocks.
6. Raise outriggers by first opening the ball valves located on outrigger legs and then engaging flex auger hydraulics (see Figure 5.1). Put locks in place and insert retaining pins (Figure 5.2).

**Note:** *Reconnect lift cylinder hose coupler to tractor, if disconnected.*

7. Move auger out of working position and lower fully by opening hose valve and tractor valve, feathering to prevent too rapid a descent.
8. Once valves are open, auger lowers by gravity. As the auger nears the full down position, the rate of descent increases. Do not operate with tractor valve fully open.
9. Lower auger using tractor hydraulics. For **SA 111**, seat lift assist arm against the track and the track shoe against the trackstop with slight tension on the lift cable.
10. Place the steering assembly in transport position. Pull out the lockpin, and fold the steering assembly down 90° (see Figure 5.1).

WARNING	
	Do not leave auger in raised position when not in use. Auger could drop rapidly due to a cable break.

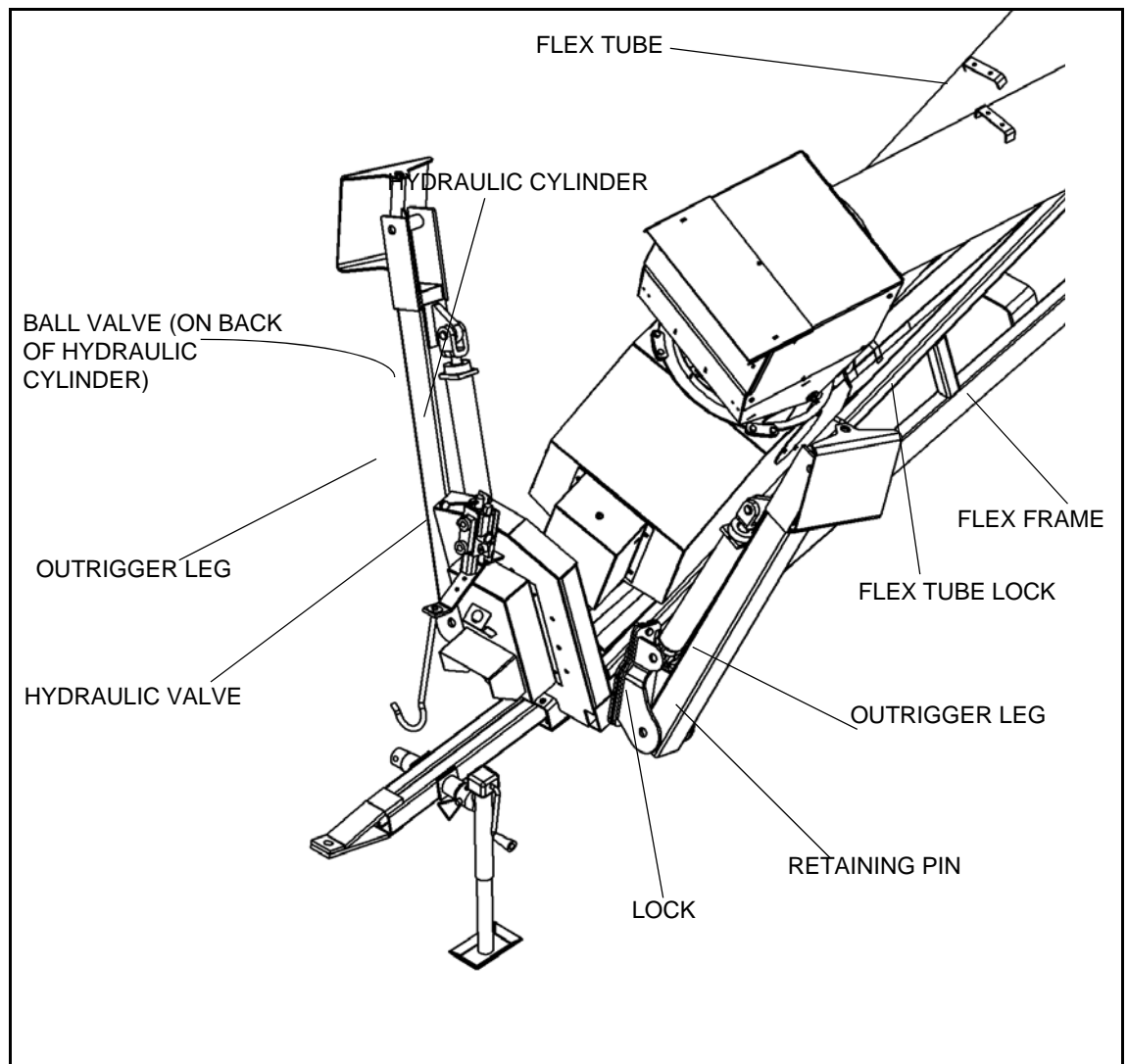

**Figure 5.2**

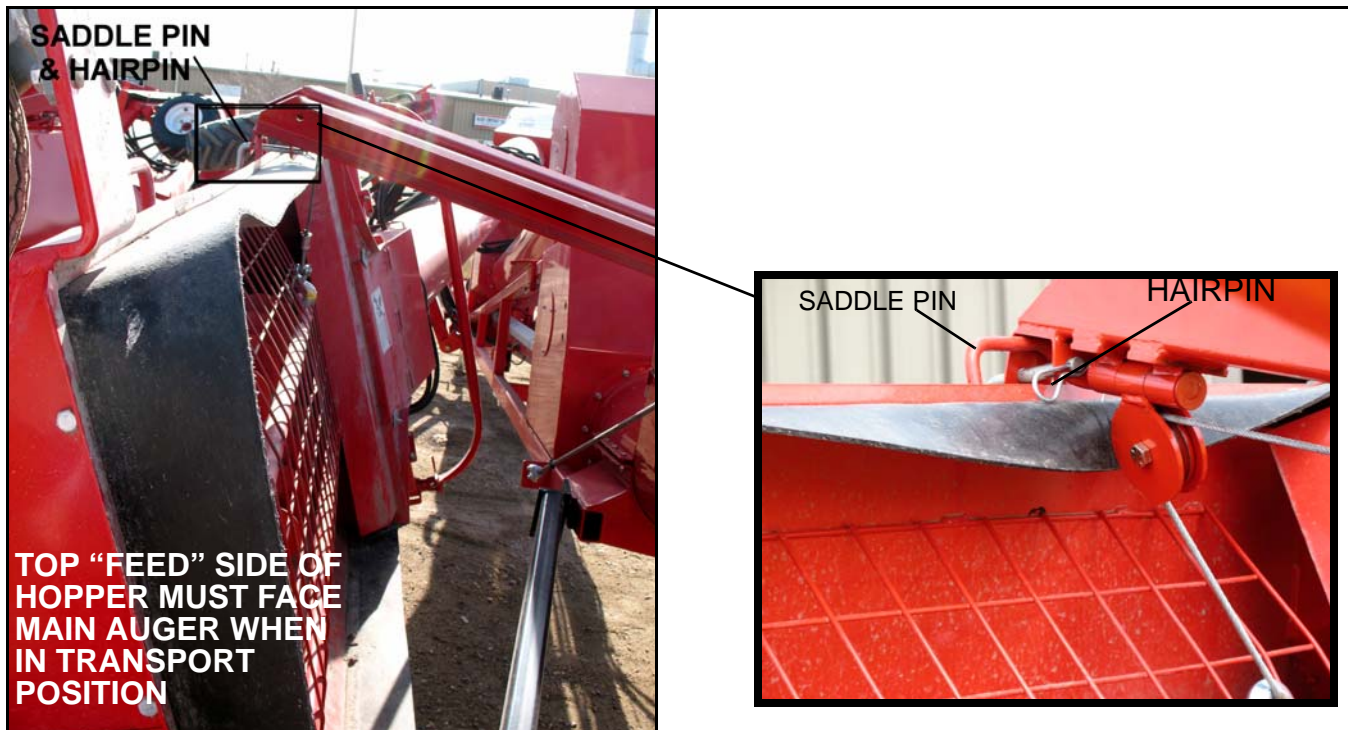

Figure 5.3

11. Attach cable hook to the loops inside the hopper (Figure 5.3).
12. Fully raise hopper with intake side facing towards the main auger as shown in Figure 5.3.
13. Secure hopper to lift arm with hopper lock, saddle pins, and hairpins provided.

**Important:** *Never operate auger with intake feed hopper in transport position. This will damage the universal joint.*

14. Clean out auger.
  - a. Shut off tractor engine and lock out power.
  - b. If necessary, open cleanout cover on the boot and manually clean out grain with a piece of wood, vacuum cleaner, or other tool. Do not use hands.
  - c. Replace cleanout cover.
15. Prepare for transport and placement or storage (see appropriate chapters for more information).

# 6. Maintenance & Storage

**WARNING** Before continuing, ensure you have read and understand the relevant information in the safety section. Safety information is provided to help prevent serious injury, death, or property damage.

## 6.1. GENERAL MAINTENANCE PROCEDURES

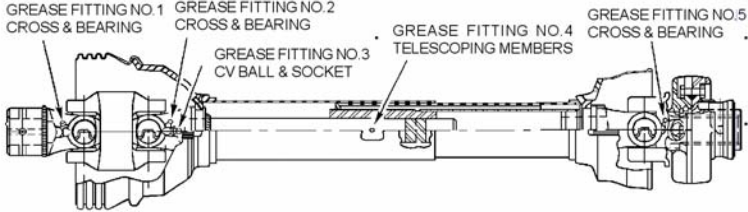

Please follow the guidelines below.

Area	Maintenance Procedures	Frequency
General	While auger is in use, observe the “Pre-Operational Checklist” on page 87.	Daily
General	Check all operating, lifting, and transport components. Replace damaged or worn parts before using auger. <ul style="list-style-type: none"> <li>For replacement instructions, see “Assembly” on page 19.</li> </ul>	Regularly
Hydraulic Hose	Using cardboard as a backdrop, check hose and hose coupler for leaks, wear, and damage. Replace if necessary. Refer to the Hydraulic Safety section. <ul style="list-style-type: none"> <li>Replacement hose and hose ends must have a minimum strength of 2750 psi (18,961 kPa) working pressure.</li> </ul>	Frequently
Lift Cable	Check and replace if frayed or damaged. Make sure cable clamps are secure.	Periodically
Cable Sheaves	Oil sheave pins on lift cylinder.	Twice/year
Truss Cables	Adjust to keep auger tube reasonably straight.	As necessary
Wheel Hubs	Repack with lithium-based grease.	Every 2–3 years
Tire Pressure	Check with a pressure gauge. Pressure should be maintained according to sidewall recommendations.	Monthly, or if it seems low
Hopper Lift Cable	Check and replace if frayed or damaged.	Periodically
Hopper Lift Cable Pulleys	Oil lightly for easier raising of hopper.	Several times a year
Outrigger Leg Cylinders	Lubricate with good quality Lithium Soap Base E.P. Grease meeting NLGI #2 specifications and containing no more than 1% molybdenum disulfide (example: Shell Super Duty).	1-2 pumps
Boot Under Flex Tube	Lubricate with good quality Lithium Soap Base E.P. Grease meeting NLGI #2 specifications and containing no more than 1% molybdenum disulfide (example: Shell Super Duty).	4-8 pumps

Area	Maintenance Procedures	Frequency															
PTO Driveline	<p>Lubricate all 5 grease fittings (“Mechanical Drive System” on page 97) with good quality Lithium Soap Base E.P. Grease meeting NLGI #2 specifications and containing no more than 1% molybdenum disulfide (example: Shell Super Duty).                      Grease fittings No. 2 and 3 can be reached through hole in implement end portion of the driveline guard.                      Grease fitting No. 4 can be reached through hole in center portion of the driveline guard.</p>  <table border="1" data-bbox="391 793 1218 1050"> <thead> <tr> <th colspan="3">LUBE RECOMMENDATIONS<sup>a</sup></th> </tr> <tr> <th>INTERVAL</th> <th>LOCATION</th> <th>AMOUNT</th> </tr> </thead> <tbody> <tr> <td>8 HRS**</td> <td>CROSS &amp; BEARING ON PTO</td> <td>1 PUMP</td> </tr> <tr> <td>8 HRS</td> <td>TELESCOPING MEMBERS ON PTO</td> <td>4-8 PUMPS</td> </tr> <tr> <td>8 HRS**</td> <td>CV BALL &amp; SOCKET ON PTO</td> <td>1-2 PUMPS</td> </tr> </tbody> </table> <p>a. **Constant angle applications must have lube interval of 4 hours.</p> <div style="border: 2px solid black; padding: 5px; text-align: center;"> <p><b>NOTICE</b></p> <p>Replacement parts are not lubricated!                      Replacement parts must be lubricated at time of assembly.                      Use amount listed above per location, then follow lube recommendations outlined above for lubing intervals.</p> </div>	LUBE RECOMMENDATIONS <sup>a</sup>			INTERVAL	LOCATION	AMOUNT	8 HRS**	CROSS & BEARING ON PTO	1 PUMP	8 HRS	TELESCOPING MEMBERS ON PTO	4-8 PUMPS	8 HRS**	CV BALL & SOCKET ON PTO	1-2 PUMPS	<p>After the first 16–24 hours, and then regularly afterward</p>
LUBE RECOMMENDATIONS <sup>a</sup>																	
INTERVAL	LOCATION	AMOUNT															
8 HRS**	CROSS & BEARING ON PTO	1 PUMP															
8 HRS	TELESCOPING MEMBERS ON PTO	4-8 PUMPS															
8 HRS**	CV BALL & SOCKET ON PTO	1-2 PUMPS															
General	Ensure that the set screws and shear-bolt are tight.	Regularly															
Low Profile Hopper	Loosen the 2 nuts securing the service door. Open door, then grease the 4 bushings and the 2 u-joints. Close door, then securely tighten the two 3/8” nuts.	Frequently															
	Check and adjust the hopper drive chain and lubricate the hopper drive chain. <ul style="list-style-type: none"> <li>To adjust chain, loosen the bearing bolts and adjust chain tension to about 1/4” (0.64 cm) deflection. <b>Replace guard.</b></li> </ul>	Occasionally															

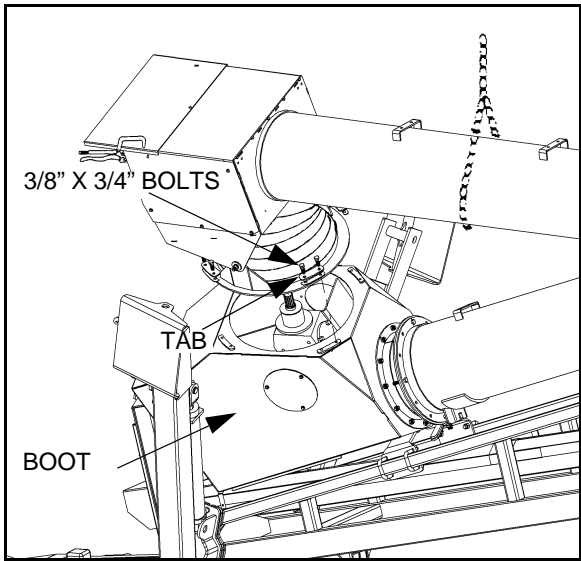

## 6.2. MECHANICAL DRIVE SYSTEM

Area	Maintenance Procedures	Frequency
Chain Drives <ul style="list-style-type: none"> <li>Replace sprocket guard after maintenance!</li> </ul>	Keep drive chain tension adjusted to about 1/4" (0.64 cm) deflection by loosening the four bolts on lower bearing, then re-tighten.	Regularly
	Oil chain often enough to keep film of oil on it (this can be done through the hole in the side of the sprocket guard).	Frequently
Universal Joint	Flip up safety discharge door and lubricate grease fitting in the u-joint. Check set screws and re-tighten if necessary. To open the other door, remove the 3 screws.	After every 8 hours of operation
	Check set screws and re-tighten if necessary.	Regularly
Gearboxes	Check oil levels in both gearboxes. They should be half full of EP90 lube oil. Fill as needed; you may need a flexible funnel. If you notice excessive loss of oil, check more frequently and repair problem. Each gearbox requires 355 mL or 12-1/2 fl oz. Do not overfill. <i>Upper Gearbox:</i> Flip up safety discharge door or open round service door to service gearbox. <i>Lower Gearbox:</i> Open round service door and fill.	At least once a year, depending on use
	<p>For more extensive servicing or repairs, remove hopper from boot assembly by removing the 3/8" x 3/4" bolts and tabs. Lift hopper with front-end loader or other secure method.</p> <p>Check and re-tighten set screws and connecting bolts. Clean and lightly grease the splined shaft. Re-attach hopper to boot assembly as per instructions in Section 3.11. or 3.12.</p> <div data-bbox="678 961 1255 1518" style="border: 1px solid black; padding: 5px;">  </div> <div data-bbox="402 1619 1263 1850" style="border: 2px solid black; padding: 10px;"> <p style="text-align: center; font-weight: bold; font-size: 1.2em;">WARNING</p> <div style="display: flex; align-items: center;">  <p>Do not operate auger with intake hopper not in place. Replace and secure service doors before operating auger.</p> </div> </div>	As required

## 6.3. STORAGE

### TO PROTECT AUGER IN STORAGE DURING THE OFF-SEASON:

1. Lower the auger to full down position with slight tension on the cable (see Operation for instructions on lowering).
2. Lubricate all grease fittings according to the maintenance procedure.
3. Inspect auger for damage and note any repairs required. Order replacement parts from your dealer.
4. Check tire pressure and inflate if necessary. See sidewall for recommended pressure.
5. Clean and re-lubricate spline on PTO driveline. Cover PTO driveline with a plastic bag to protect it from the weather and place it in transport saddle.
6. Tow auger to storage area. Park and chock wheels.

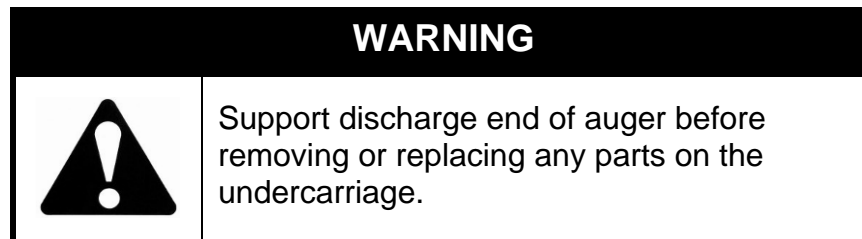

### TO PREPARE AUGER FOR USE AFTER STORAGE:

1. Check tire pressure and inflate if necessary. See sidewall for recommended pressure.
2. Tow auger to work site.
3. Remove cover from spline of PTO driveline and re-lubricate.
4. Check oil level in gearbox and refill if necessary (half full only).
5. Replace any damaged parts and decals.
6. Check and perform general maintenance before using auger.
7. Before raising auger after storage, make certain cable is in good condition, replacing it if frayed or damaged. Also make sure cable is properly seated in roller track and that cable clamps are secure.

**Note:** *Use only genuine Westfield replacement parts or equivalent. Replacement parts such as intake guards, pulley guards, PTO driveline shields, winches and lift cables Must meet ASAE standards or serious injury may result. Use of unauthorized parts will void warranty. If in doubt, contact Westfield or your Westfield dealer. Do not modify any auger components.*

# 7. Troubleshooting

Problem	Possible Cause	Remedy
<p><b>Excessive noise or vibration.</b></p> <p>*Remember to follow proper break-in procedures—auger may run rough until tube is polished. If noise is extreme from outset or continues after several loads of grain are fed, continue with troubleshooting below.</p>	<p>Determine if noise originates in main or swing away section of auger. Disconnecting the chain from the sprocket drive can assist in narrowing down the source of the problem. <b>If noise <i>disappears</i> when chain is disconnected, problem is likely in the swing away auger.</b></p>	
	<p>Hopper flight support bearings are dry or have failed.</p>	<p>Check for flight operation by rotating by hand with sprocket chain disconnected and tractor shut off. Grease or replace as necessary.</p>
	<p>Universal joint not greased or is faulty.</p>	<p>Grease or replace as necessary.</p>
	<p>Faulty upper gearbox.</p>	<p>Refer to appropriate troubleshooting section.</p>
	<p>Obstruction in tube.</p>	<p>Visually inspect for cloth or trash wrapped around flighting, or a buildup from oily crops.</p>
	<p>Bent flight stub on swing flighting.</p>	<p>Remove flighting and roll against flat surface to determine if stub is true.</p>
	<p><b>If noise <i>continues</i> when chain is disconnected, check auger or PTO.</b></p>	
	<p>CV PTO failure.</p>	<p>Refer to appropriate troubleshooting section.</p>
	<p>Incorrectly adjusted truss cables.</p>	<p>Support end of auger and adjust cables so auger is flat or slightly curved upwards.</p>
	<p>Flighting has peeled back due to plugging.</p>	<p>Inspect spout end of auger for flight condition. Remove and replace flight sections as necessary.</p>
	<p>Faulty lower gearbox.</p>	<p>Refer to appropriate troubleshooting section.</p>
	<p>Lower bearing dry or has failed.</p>	<p>Refer to appropriate troubleshooting section.</p>
	<p>Bent flighting section.</p>	<p>Support auger and remove all flight sections. Check for straightness of flight stubs by rolling across flat section of concrete floor. Straighten stub or replace as necessary. Take care not to bend flighting when reinstalling.</p>
	<p>Obstruction in tube.</p>	<p>Visually inspect for cloth or trash wrapped around flighting, or a buildup of gum from oily crops such as flax or canola.</p>
<p>High spot at flighting joints.</p>	<p>Check with straight edge. If necessary, grind down until even.</p>	

Problem	Possible Cause	Remedy
<b>CV PTO failure.</b>	<b>Try to determine the operation and maintenance habits of the owner in order to avoid multiple repairs and unnecessary frustration.</b>	
	Broken CV ball.	Most frequently occur when PTO driveline is not disconnected during transport or setup of the auger. Remind all operators to disconnect PTO driveline except when at the bin in operation.
	Excessive PTO angle.	Check manual for correct dimensions (auger input and tractor PTO output). It may be necessary to raise tractor drawbar to maintain correct dimensions. Extreme side-to-side angles that are necessary because of the bin and tractor placement may be corrected with a right angle drive kit.
	Early series cross-link or non-Wheatheart part used.	Ensure new "E" series cross links and genuine Wheatheart replacement parts are used.
	Telescoping part of PTO shaft bottoming out.	Pull out or lengthen tractor drawbar to maintain minimum clearance.
Bearings not receiving adequate grease.	Check manual—CV PTO drivelines should be greased as part of daily maintenance procedures.	
<b>Premature gearbox failure.</b>	<b>While all gearboxes come from the factory filled with oil, it should be part of the setup procedure to double check that a half full level is maintained.</b>	
	Failed seal.	Check gearbox levels on a regular basis and only fill with EP90 oil.
	1000 rpm tractor input being used.	Use 540 rpm tractor or install speed reducer.
<b>Shear bolts fail repeatedly.</b>	Incorrect shear bolt type.	Replace with correct part number. Wheatheart shear bolts are specifically designed to provide correct driveline protection.
	Shear bolt hole worn out-of-round.	Frequent use of an incorrect shear bolt size can wear the mounting hole creating a "scissor effect," which will require replacement of the affected parts.
	Corn spreaders in bin unable to keep up with auger output.	Slow down auger or remove corn spreaders.
	Flighting "peeled back" as a result of plugging.	Occurs when bin has overfilled or corn spreaders restrict end of discharge. Inspect flighting at discharge end. If necessary, replace flighting.
	Driveline failures (bearing, gearbox, etc.).	Refer to appropriate troubleshooting section.

<b>Problem</b>	<b>Possible Cause</b>	<b>Remedy</b>
<b>Lower bearings repeatedly fail.</b>	Bearings not receiving adequate grease.	Check manual for correct greasing intervals.
	Bearing load not evenly distributed between upper and lower bearings.	Use correct sequence of tightening lock collars when setting up or replacing bearings. Adjust bearing load using threaded upper flight stub.
	Insufficient CV PTO shaft clearance.	Maintain correct tractor hitch dimensions as per manual.
	Failure of bearing seals.	Wet grain or fertilizer will damage seals if left in boot over time. Clean out boot before storing auger.
	Bent lower flight stub.	Check for straightness of flight stub by rolling across flat concrete section. Straighten stub or replace as necessary.
<b>Premature wear on auger tubes.</b>	Auger being run at low capacity or empty for extended periods of time.	Frequently occurs on farms using grain wagons. Auger should not be left unattended when filling bins. Depending on application, a belt conveyor may be more appropriate.
	Bent flighting.	Refer to appropriate troubleshooting section.
	Flighting allowed to wear beyond normal point of replacement.	When flighting becomes razor-thin at intake, replacement is critical. Since flight material is double thickness at welded lap joints, high spots on flight occur and can accelerate spot tube wear.
<b>Hydraulic lift settles out over time.</b>	Shut off ball valve is open.	Oil is leaking through tractor valve. Auger ball valve should be closed whenever set up at a bin.
	Shut off ball valve is leaking.	Disconnect hose from tractor and check for leakage.
	Lift cylinder cup seal leaking or cylinder barrel scored or pitted.	See if oil leaks from cylinder breather hole (single action cylinders). Remove and replace cup seal and hone cylinder or replace as needed.
<b>Hydraulic controlled tube doesn't swing in or out.</b>	Transport lock pin engaged.	Disengage pin.
<b>No or minimal hydraulics function.</b>	Hydraulic flow going to valve in wrong direction.	Reverse tractor hydraulics or move hydraulic lever opposite.
<b>Hydraulic control tube hits transport rest plate, won't roll on smoothly.</b>	Mis-adjusted roller on flex tube.	Adjust height. Adjust roller.



# 8. Appendix

## 8.1. SPECIFICATIONS

**Important:** *Westfield Industries reserves the right to change specifications without notice.*

**Table 8.1**

	71'	81'	91'	111'	
<b>CAPACITY</b>					
Unloading Rate	8700 - 9600 Bu/Hr				
<b>DIMENSIONS</b>					
Tube Size	13" (33.0 cm)	13" (33.0 cm)	13" (33.0 cm)	13" (33.0 cm)	
Height Lowered (A)	12'0" (3.66 m)	10'7" (3.23 m)	12'6" (3.81 m)	15'0" (4.57 m)	
Height Halfway (B)	32'2" (9.80 m)	31'5" (9.85 m)	36'0" (10.97 m)	42'6" (12.95 m)	
Height Raised (C)	46'0" (14.0 m)	51'9" (15.77 m)	59'6" (18.13 m)	71'6" (21.79 m)	
Reach Lowered (D)	33'7" (10.24 m)	41'3" (12.58 m)	44'8" (13.61 m)	54'7" (16.64 m)	
Reach Halfway (E)	30'9" (9.73 m)	38'7" (11.78 m)	41'5" (12.63 m)	50'11" (15.52 m)	
Reach Raised (F)	27'2" (8.28 m)	32'0" (9.75 m)	34'8" (10.56 m)	42'6" (12.95 m)	
Height at Arms (G)	20'2" (6.15 m)	22'4" (6.81 m)	23'3" (7.09 m)	27'8" (8.43 m)	
Height at Wheels (H)	25'7" (7.80 m)	27'2" (8.28 m)	28'6" (8.68 m)	33'5" (10.15 m)	
Reach to Arms (I)	27'7" (8.41 m)	26'6" (8.07 m)	31'4" (9.55 m)	38'5" (11.71 m)	
Reach to Wheels (J)	27'9" (8.46 m)	30'8" (9.34 m)	38'4" (11.68 m)	48'9" (14.84 m)	
Width (transport)	10'4" (3.15 m)	9'4" (2.84 m)	14'8" (4.47 m)	15'4" (4.67 m)	
Width (with axles extended)	--	12'4" (3.76 m)	17'8" (5.38 m)	18'4" (5.59 m)	
<b>TIRES</b>					
Type	16" Bias Ply				
Hubs	6 Bolt Automotive Type				
<b>WEIGHT</b>					
Weight (lb)	Total Weight	6675	7480	7930	9380
	Axle Weight	4175	4980	5430	7100
	Hitch Weight	2500	2500	2500	2280
<b>PTO DRIVE</b>					
Power Requirements	100 HP	120 HP	140 HP	160 HP	
PTO Speed	540 rpm				
PTO Shaft	35R				
<b>OTHER</b>					
Hitch Jack	5000 lb Square Tube				

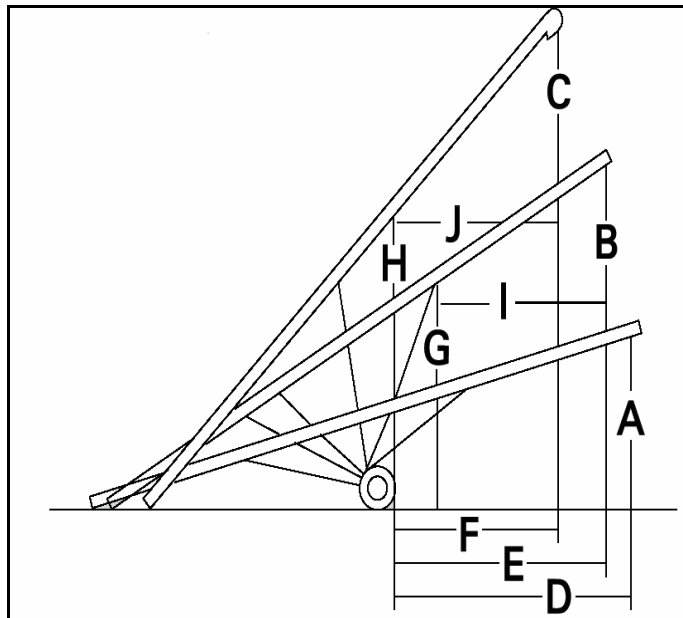

Figure 8.1

## 8.2. LIFT CYLINDER HYDRAULICS (81'/91'/111')

The 81'/91'/111' auger is elevated with 2 specially-designed, double-acting hydraulic cylinders and cables. The following table lists the psi required to raise specific auger sizes (as determined by testing).

These tests used a hydraulic pressure gauge (4000 psi maximum rating) and are solely intended to be used as a guide. The psi requirements for specific augers may vary slightly. Should your auger require a significantly higher psi to raise, contact either your dealer or Westfield Industries.

SIZE	PSI	kPa
81'	1500	10,343
91'	1950	13,443
111'	2000	13,790

The approximate quantity of hydraulic fluid required to raise auger is 4 liters.

## 8.3. HOW TO CHARGE THE LIFT SYSTEM

The cylinders will require approximately 19 L (5 US gallons). Check your tractor's operation manual for correct oil type and specifications.

Before charging cylinders, ensure that the:

- Tractor is correctly hooked up.
- Hydraulic hoses are connected.
- Shut-off valve is open.
- Auger is parked on level ground.
- Cables are seated in pulleys and are in good condition.

**Note:** *Do not raise auger in high winds.*



1. Start with the tractor's hydraulic oil level in a normal operating range.
2. Add about **4 L** (1 US gallon) to the tractor's hydraulic oil reservoir.
3. Start tractor, then raise auger until the lift-assist is fully extended and track shoe has moved about 1' from trackstop.
4. **With tractor still running**, lower auger to full down position.
5. Repeat Steps 2., 3., and 4. until about 19 L (5 US gallons) have been added and tractor hydraulic oil level in the reservoir remains within the operating range.

### 8.3.1. HYDRAULIC MOTOR NOTES

Do not exceed a constant back pressure of 300 psi (2068 kPa) in the hydraulic motor.

- The hydraulic system on some tractors is designed so that the return flow of hydraulic fluid from the hydraulic motor to the tractor is restricted. This creates excessive back pressure inside the hydraulic motor and deprives it of an adequate flow of hydraulic fluid. The result will be **seal failure, overheating, rough running, and loss of power**.

To date, these problems occur primarily with certain John Deere tractors. Kits to correct the problem are available from your John Deere dealer (Figure 8.2).

**Important:** *John Deere Series 50 tractors with a single hydraulic lever will require this kit. Series 50 tractors with double hydraulic levers have the kit pre-installed.*

**Note:** *The problem discussed in this section may exist on tractors other than the John Deere. Should you experience this situation, contact your tractor dealer or Westfield Industries.*

A remote cylinder control valve oil return kit, which returns oil to the oil filter cover, is available for more efficient use of tractor hydraulics. Order AR71945 Remote Cylinder Control Valve Oil Return kit and AT30197 Ported Cover for transmission filter.

#### IMPORTANT

A steel-encased filter element must be used with the AT30197 Ported Filter Cover.

W8058

INFORMATION COURTESY JOHN DEERE MANUAL "PREPARING THE TRACTOR."

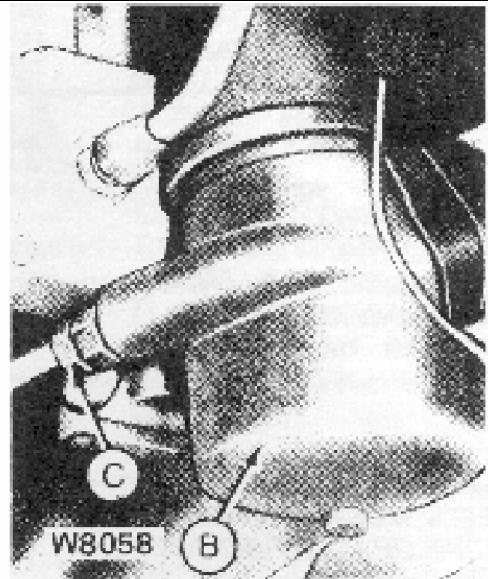

Figure 8.2



# WARRANTY

Westfield Industries Ltd. warrants products of its manufacture against defects in materials or workmanship under normal and reasonable use for a period of one year after date of delivery to the original purchaser.

Our obligation under this warranty is limited to repairing, replacing, or refunding defective part or parts which shall be returned to a distributor or a dealer of our Company, or to our factory, with transportation charges prepaid. This warranty does not obligate Westfield Industries Ltd. to bear the cost of labor in replacing defective parts. Any defects must be reported to the Company before the end of the one year period.

This warranty shall not apply to equipment which has been altered, improperly assembled, improperly maintained, or improperly repaired so as to adversely affect its performance. Westfield Industries Ltd. makes no express warranty of any character with respect to parts not of its manufacture.

The foregoing is in lieu of all other warranties, expressed or implied, including any warranties that extend beyond the description of the product, and the IMPLIED WARRANTY of MERCHANTABILITY is expressly excluded.

WESTFIELD INDUSTRIES LTD.

ROSENORT, MANITOBA

CANADA

R0G 1W0

# **WESTFIELD**

Westfield Industries

Part of the Ag Growth International Inc. Group

P.O. Box 39

Rosenort, Manitoba, Canada R0G 1W0

Phone: (866) 467-7207 (Canada & USA)

Fax: (866) 768-4852

website: [www.grainaugers.com](http://www.grainaugers.com)

email: [sales@grainaugers.com](mailto:sales@grainaugers.com)

© Ag Growth International Inc. 2013



Printed in Canada