

# **WESTFIELD**<sup>®</sup>

## **GRAIN AUGERS**

**MK 130 PLUS X 61' - 81'  
ASSEMBLY & OPERATION**



Read this manual before using product. Failure to follow instructions and safety precautions can result in serious injury, death, or property damage. Keep manual for future reference.

Part Number: 30259

Revised: 10/2/10



# TABLE OF CONTENTS

<b>1. Introduction .....</b>	<b>5</b>
<b>2. Safety First.....</b>	<b>7</b>
2.1. General Safety .....	8
2.2. Assembly Safety.....	9
2.3. Operation Safety .....	9
2.4. PTO Safety .....	10
2.5. Hydraulic Safety .....	11
2.6. Transport & Placement Safety .....	12
2.7. ....	12
2.8. Maintenance Safety.....	13
2.9. Safety Decal Locations.....	13
2.9.1. Decal Installation .....	13
2.9.2. Decal Locations .....	13
<b>3. Assembly .....</b>	<b>19</b>
3.1. Tube and Flight .....	19
3.2. Track Shoe, Trackstop, & Lift-Assist Arm.....	20
3.3. Tow Bar .....	22
3.4. Boot .....	23
3.5. Discharge Spout.....	24
3.6. Thrust Adjuster .....	24
3.7. Truss .....	25
3.8. Transport Undercarriage .....	28
3.9. Lift Cylinder / Cable .....	33
3.9.1. MK130 Plus 61'/71' .....	33
3.9.2. MK130 Plus 81' .....	35
3.10. Hydraulic Hoses .....	37
3.10.1. MK130 61'/71' .....	37
3.10.2. MK130 81' .....	38
3.11. PTO (CV) Driveline.....	39
3.12. Standard Intake Hopper .....	40
3.12.1. Hopper lift Extension .....	43
3.12.2. Hopper Lift Arm / Winch .....	43
3.13. Optional Low Profile Hopper .....	44
3.14. Hitch Jack.....	46
3.15. Auger-to-Tractor Hookup.....	47
3.15.1. PTO Driveline / Drawbar.....	47
3.15.2. Hydraulic Hose Couplers.....	49
3.16. Plastic Manual Holder .....	49
<b>4. Transport &amp; Placement .....</b>	<b>51</b>
4.1. Transport Procedure .....	51
4.2. Placement Procedure .....	53

# TABLE OF CONTENTS

<b>5. Operation</b> .....	<b>57</b>
5.1. Pre-Operation Checklist .....	57
5.2. Auger Drive & Lockout Procedure .....	58
5.3. Hydraulics .....	58
5.4. Operating Procedure .....	59
5.4.1. Initial Start-Up .....	59
5.4.2. Operating with a Full Load .....	59
5.4.3. Shutdown .....	60
5.4.4. Lowering & Completion .....	61
<b>6. Maintenance &amp; Storage</b> .....	<b>63</b>
6.1. General Maintenance Procedures .....	63
6.2. General Storage Procedure .....	67
<b>7. Troubleshooting</b> .....	<b>69</b>
<b>8. Appendix</b> .....	<b>73</b>
8.1. Lift Cylinder Hydraulics .....	73
8.2. Charging Lift System (MK130 Plus 81' Only) .....	73
Warranty .....	75

# 1. Introduction

Congratulations. As the new owner of a grain auger, you will be working with equipment designed to complement and improve your farming operation. Before using this auger, please read this manual and all safety labels and familiarize yourself with the various features of the machine and the necessary precautions for efficient and safe operation.

In addition, anyone using this auger is required to comply with all safety precautions in this manual and in safety labels attached to the auger. A sign-off form is supplied on the inside front cover to record your safety reviews.

Thank you.



<b>Serial Number:</b>	
*Serial number is located on the lower tube.	



## 2. Safety First



The Safety Alert symbol to the left identifies important safety messages on the product and in the manual. When you see this symbol, be alert to the possibility of personal injury or death. Follow the instructions in the safety messages. Why is SAFETY important to you?

Three big reasons:

- Accidents disable and kill.
- Accidents cost.
- Accidents can be avoided.

### SIGNAL WORDS

Note the use of the signal words **DANGER**, **WARNING**, **CAUTION**, and **NOTICE** with the safety messages. The appropriate signal word for each message has been selected using the definitions below as a guideline.

The Safety Alert symbol means ATTENTION, BE ALERT!, YOUR SAFETY IS INVOLVED.

#### DANGER



Indicates an imminently hazardous situation that, if not avoided, will result in serious injury or death.

#### WARNING



Indicates a hazardous situation that, if not avoided, could result in serious injury or death.

#### CAUTION



Indicates a hazardous situation that, if not avoided, may result in minor or moderate injury.

#### NOTICE

Indicates a potentially hazardous situation that, if not avoided, may result in property damage.

## 2.1. GENERAL SAFETY

**Important:** *The general safety section includes instructions that apply to all safety practices. Any instructions specific to a certain safety practice (e.g., assembly safety), can be found in the appropriate section. Always read the complete instructional sections and not just these safety summaries before doing anything with the equipment.*

**YOU** are responsible for the **SAFE** use and maintenance of your equipment. **YOU** must ensure that you and anyone else who is going to work around the equipment understands all procedures and related **SAFETY** information contained in this manual.

Remember, **YOU** are the key to safety. Good safety practices not only protect you, but also the people around you. Make these practices a working part of your safety program.

- It is the equipment owner and the operator's responsibility to read and understand **ALL** safety instructions, safety decals, and manuals and follow them before assembling, operating, or maintaining the equipment. All accidents can be avoided.
- Equipment owners must give instructions and review the information initially and annually with all personnel before allowing them to operate this product. Untrained users/operators expose themselves and bystanders to possible serious injury or death.
- Use this equipment for its intended purposes only.
- Do not modify the equipment in any way. Unauthorized modification may impair the function and/or safety, and could affect the life of the equipment. Any modification to the equipment voids the warranty.
- Do not allow children, spectators, or bystanders within the work area.
- Have a first-aid kit available for use should the need arise, and know how to use it.
- Provide a fire extinguisher for use in case of an accident. Store in a highly visible place.
- Wear appropriate protective gear. This list includes, but is not limited to:
  - a hard hat
  - gloves
  - protective shoes with slip-resistant soles
  - protective goggles
  - hearing protection
- For Powered Equipment: before servicing, adjusting, or repairing powered equipment, unplug, place all controls in neutral or off position, stop the engine or motor, remove ignition key or lock out power source, and wait for all moving parts to stop.





- Follow good shop practices:
  - keep service area clean and dry
  - be sure electrical outlets and tools are properly grounded
  - use adequate light for the job at hand
  - Think SAFETY! Work SAFELY!



## 2.2. ASSEMBLY SAFETY

---

- Read through the instructions to get to know the sub-assemblies and hardware that make up the equipment.
- Do not take chances with safety. The components are large, heavy, and can be hard to handle. Always use the proper tools, stands, jacks, and hoists for the job.
- Always have 2 or more people assembling the equipment. Because of the weight, do not attempt assembly alone.

## 2.3. OPERATION SAFETY

---

- Have another trained person nearby who can shut down the auger in case of accident. Always work with a second trained person around augers.
- Do not operate with any of the safety guards removed.
- Keep body, hair, and clothing away from moving parts. Stay away from intake during operation.
- Inspect lift cable before using auger. Replace if frayed or damaged. Make sure it is seated properly in cable sheaves and cable clamps are secure.
- Operate auger on level ground free of debris. If ground is uneven, anchor the auger to prevent tipping or upending.
- Augers are not insulated. Keep away from electrical lines. Electrocuting can occur without direct contact.
- Support the discharge end and/or anchor the intake end before operating to prevent upending.
- Do not use auger as a hoist.
- Empty auger before raising or lowering.
- Lower auger at completion of operation or when not in use. Auger could drop rapidly in case of cable break or hydraulic failure (where applicable).
- Do not get on or beneath auger when raising or lowering intake hitch jack, or when auger is supported by hitch jack.
- Do not operate auger with the service or cleanout doors open or unlatched.

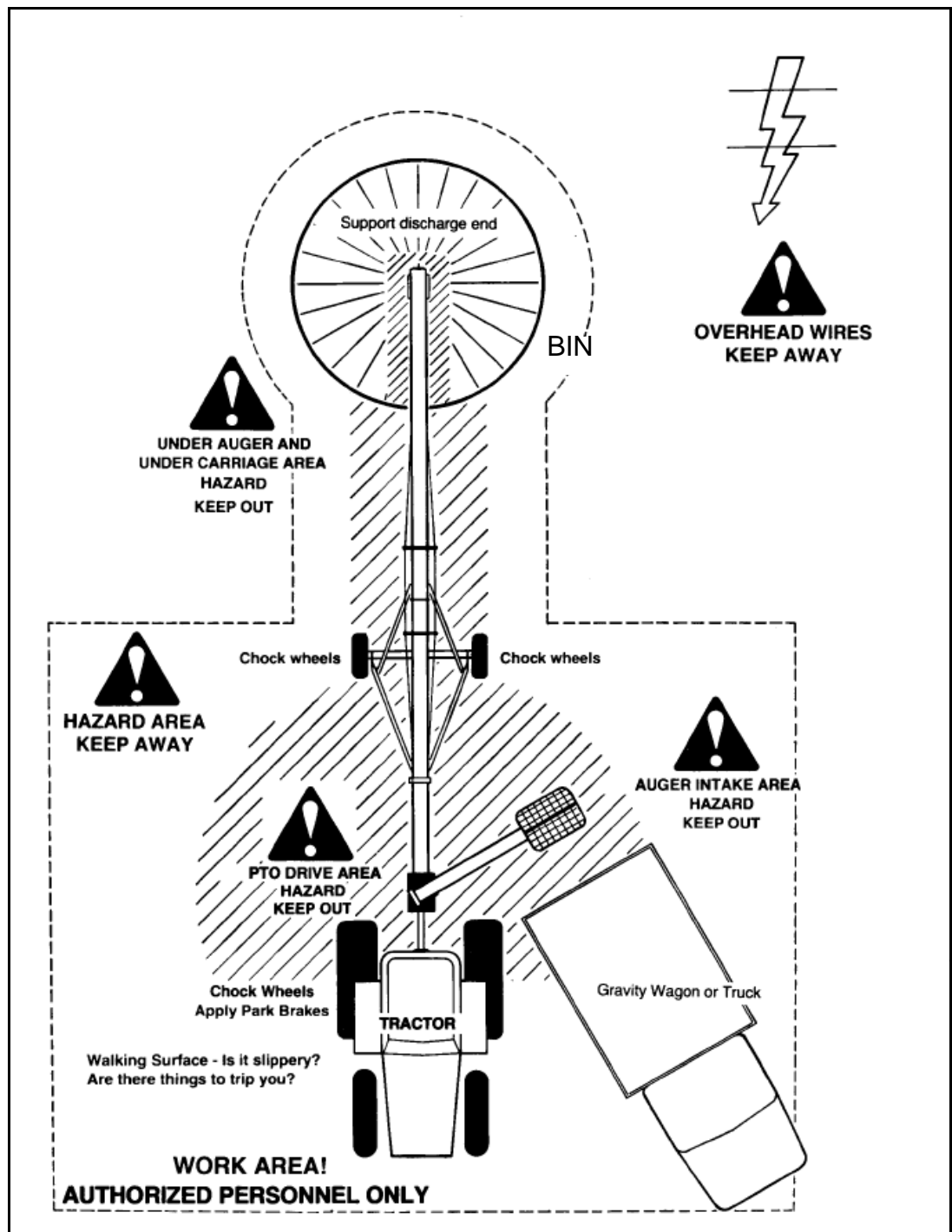

Figure 2.1

## 2.4. PTO SAFETY

- Never use a PTO driveline without a rotating shield in good working order.
- Ensure PTO driveline is securely attached at both ends before operating.
- Before starting tractor, turn power to PTO to the off position (where applicable).
- Keep body, hair, and clothing away from rotating PTO driveline.
- Ensure the driveline shields turn freely on driveline.

- Do not exceed operating speed of 540 rpm.
- Keep u-joint angles small and equal. Do not exceed recommended operating length for PTO driveline.

## 2.5. HYDRAULIC SAFETY

---

- Wear proper hand and face protection when searching for hydraulic leaks. Escaping fluid under pressure can penetrate the skin, causing serious injury like gangrene. In case of accident, see a doctor immediately.
- Fluid leaks in the hydraulic lift cylinders or hoses will allow the auger to lower inadvertently. Repair all leaks and breaks immediately. Rupture could cause damage and/or personal injury.
- A hydraulic lift is faster than a conventional hand crank—always clear area of personnel before raising or lowering.
- Do not disconnect hydraulic couplers when hydraulic system is pressurized. For the correct procedure, consult this manual or your tractor manual.
- Relieve pressure before unhooking hydraulic lines.
- Inspect hydraulic fittings and hoses for damage on a daily basis. Repair if damaged.
- Ensure that the hydraulic line is properly connected and secure.
- Keep hydraulic line away from moving parts.
- Clean connections before connecting to equipment.

## 2.6. TRANSPORT & PLACEMENT SAFETY

- Transport auger in full down position with slight tension on cable.
- Properly place hitch pin and securely attach safety chain. Use a type of hitch pin that will not allow auger to separate from towing vehicle.
- Always attach an SMV (slow moving vehicle) sign before transporting auger. Equip the auger with the necessary lights for transportation where required by law. Always use hazard warning flashers on the tractor/towing vehicle when transporting unless prohibited by law.
- Always travel at a safe speed, never exceeding 15 mph (24 km/hr). Reduce speed on rough surfaces and be cautious when turning corners or meeting traffic.
- Before raising/lowering/moving the auger, make sure the area around the auger is clear of obstructions and/or untrained personnel. Never allow anyone to stand on or beneath auger while transporting or placing auger.
- Do not transport auger on slopes greater than 20°.
- Wheels must be free to move when raising or lowering auger.
- Never attempt to move auger manually. To do so will result in serious injury.
- Before moving auger, check and double check for overhead obstructions and/or electrical wires. Electrocutation can occur without direct contact.
- Disconnect PTO driveline from tractor before moving auger or tractor and secure in transport saddle (where applicable).
- Raise intake feed hopper into transport position and lock hopper lift winch before transporting or moving auger. Intake feed side of hopper must face main auger when in transport position.
- Do not operate auger with intake hopper in transport position. This will cause damage to the u-joint.

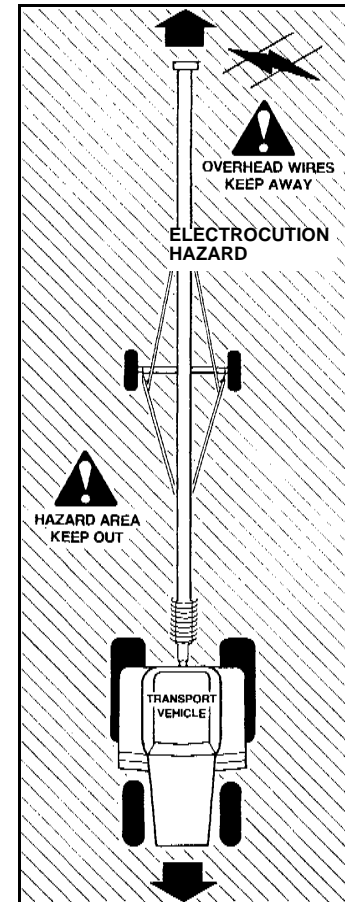

## 2.7. MAINTENANCE SAFETY

- Shut down and lock out all power before attempting maintenance of any kind. **If applicable**, disconnect PTO driveline from tractor or hydraulic hoses on units with hydraulic drive hoppers.
- After maintenance is complete, replace and secure all safety guards and safety devices, and if applicable, service doors and cleanout covers.
- Support auger tube before attempting maintenance on the undercarriage assembly. Auger should be in full down position for maintenance.

- Use only genuine Westfield replacement parts or equivalent. Replacement parts such as intake guards, pulley guards, PTO driveline shields, winches, and lift cables must meet ASABE standards or serious injury may result. Use of unauthorized parts will void warranty. If in doubt, contact Westfield or your Westfield dealer.
- Do not modify any auger components without authorization from Westfield. Modification can be dangerous and result in serious injuries.

## 2.8. SAFETY DECAL LOCATIONS

---

- Keep safety decals clean and legible at all times.
- Replace safety decals that are missing or have become illegible. See decal location figures below.
- Replaced parts must display the same decal(s) as the original part.
- Safety decals are available from your distributor, dealer, or factory.

### 2.8.1. DECAL INSTALLATION

---

1. Decal area must be clean and dry, with a temperature above 10°C (50°F).
2. Decide on the exact position before you remove the backing paper.
3. Align the decal over the specified area and carefully press the small portion with the exposed sticky backing in place.
4. Slowly peel back the remaining paper and carefully smooth the remaining portion of the decal in place.
5. Small air pockets can be pierced with a pin and smoothed out using the sign backing paper.

### 2.8.2. DECAL LOCATIONS

---

Replicas of the safety decals that are attached to the equipment are shown in the figure(s) that follow. Good safety requires that you familiarize yourself with the various safety decals and the areas or particular functions that the decals apply to as well as the safety precautions that must be taken to avoid serious, injury, death, or damage.

Please review the decals shown. If your auger does not have these decals, they are available upon request. Please specify which decals you need.

*\* Westfield reserves the right to update safety decals without notice. Safety decals may not be exactly as shown.*

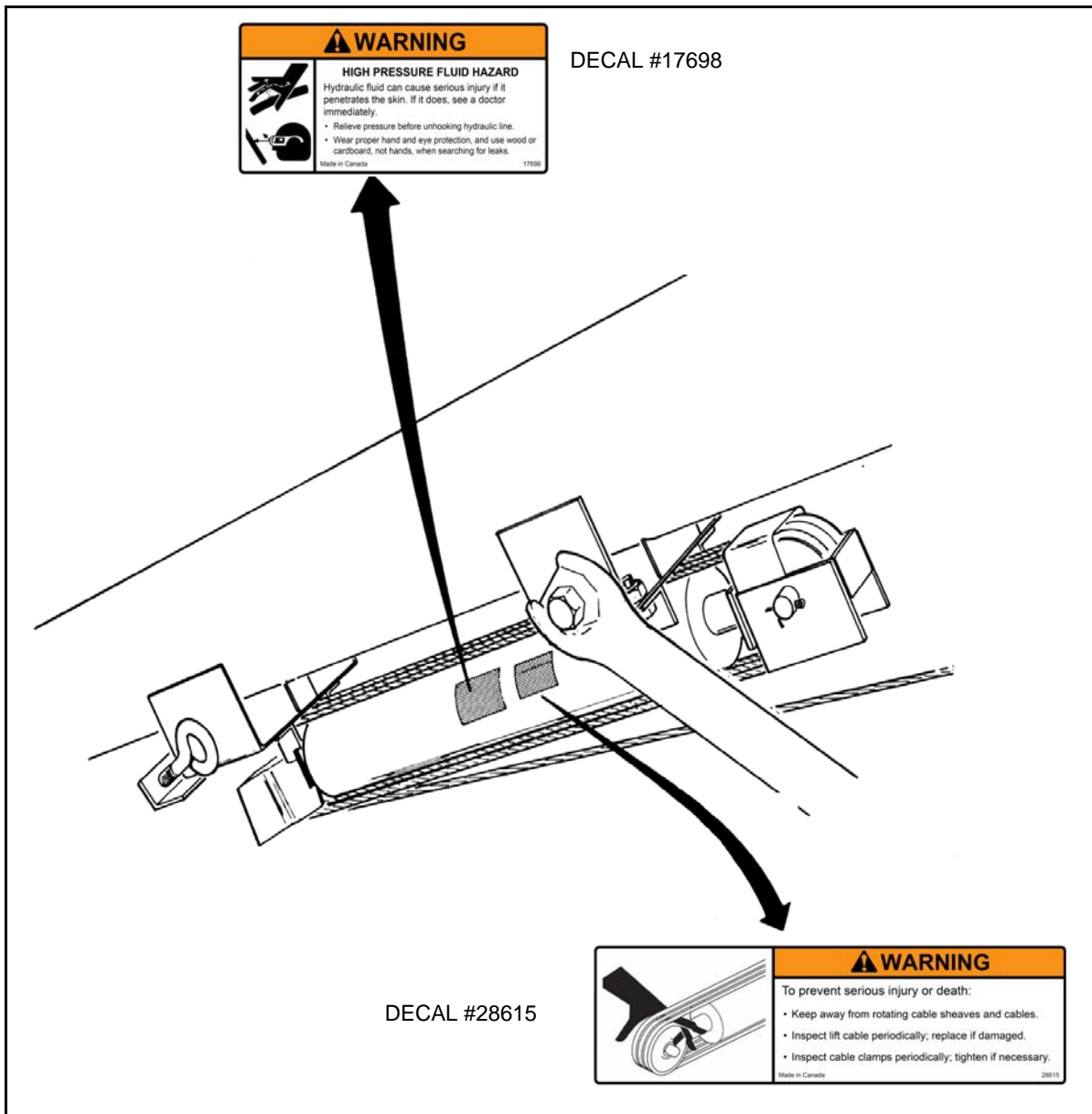

Figure 2.2

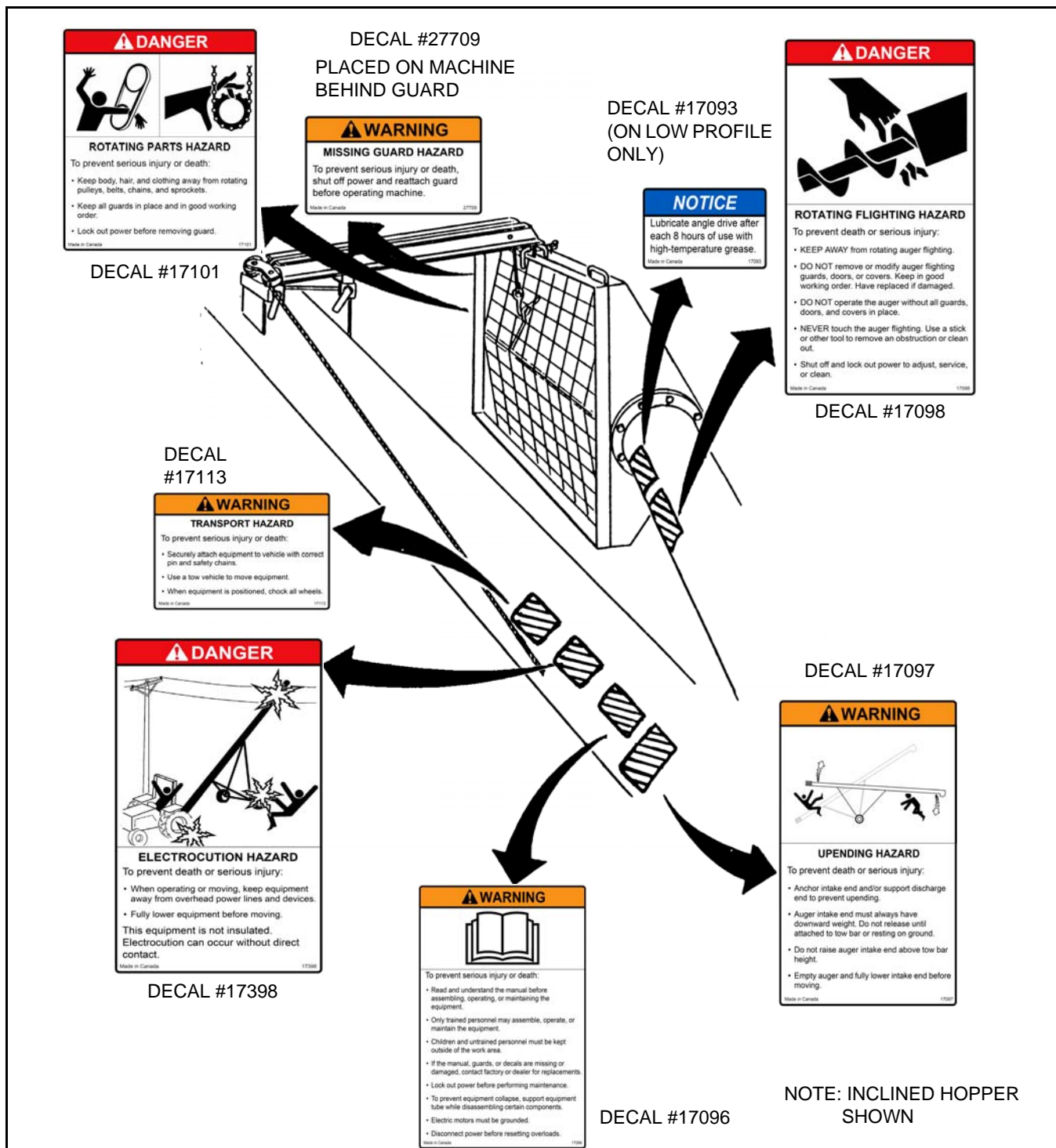

Figure 2.3

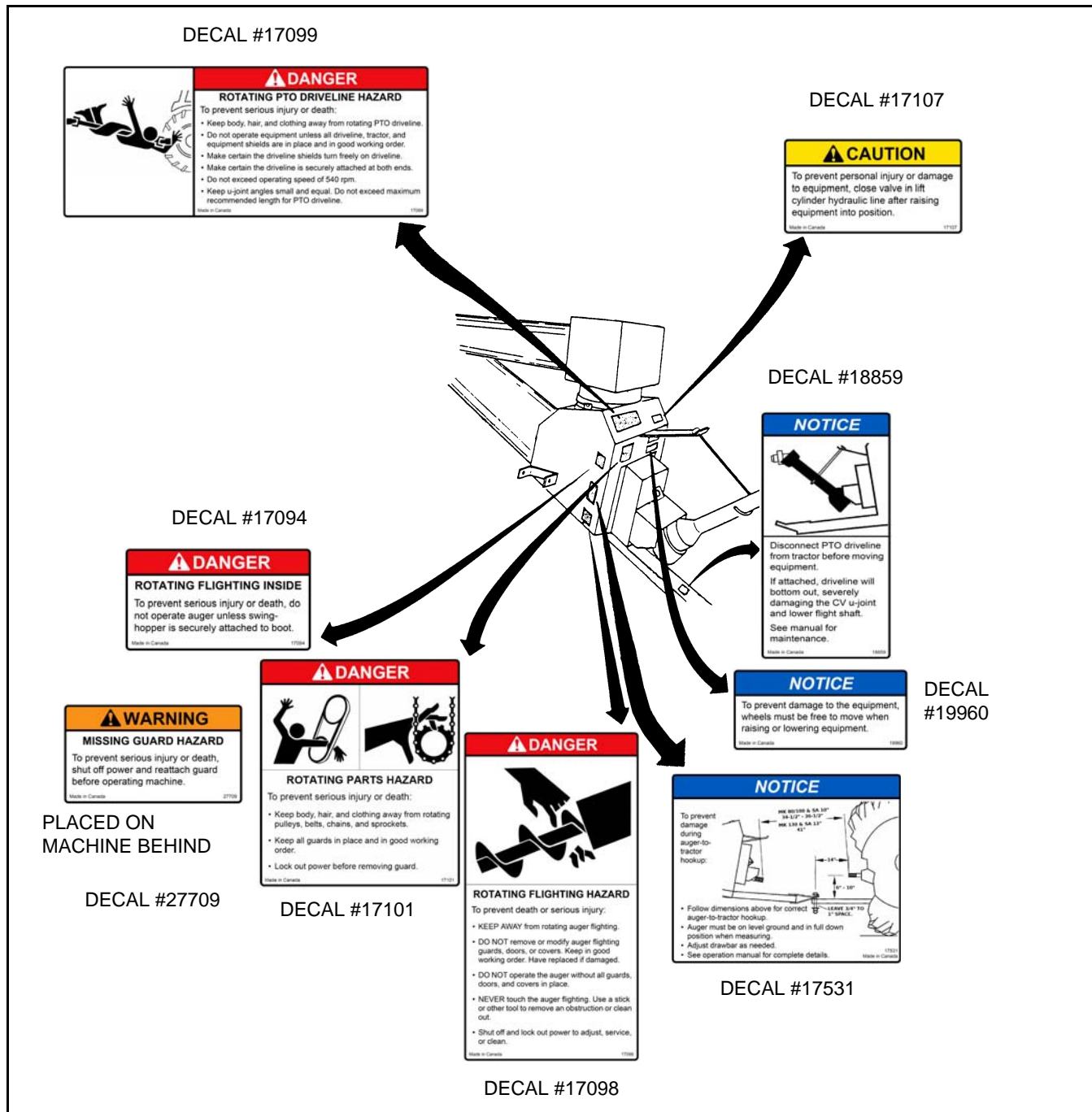
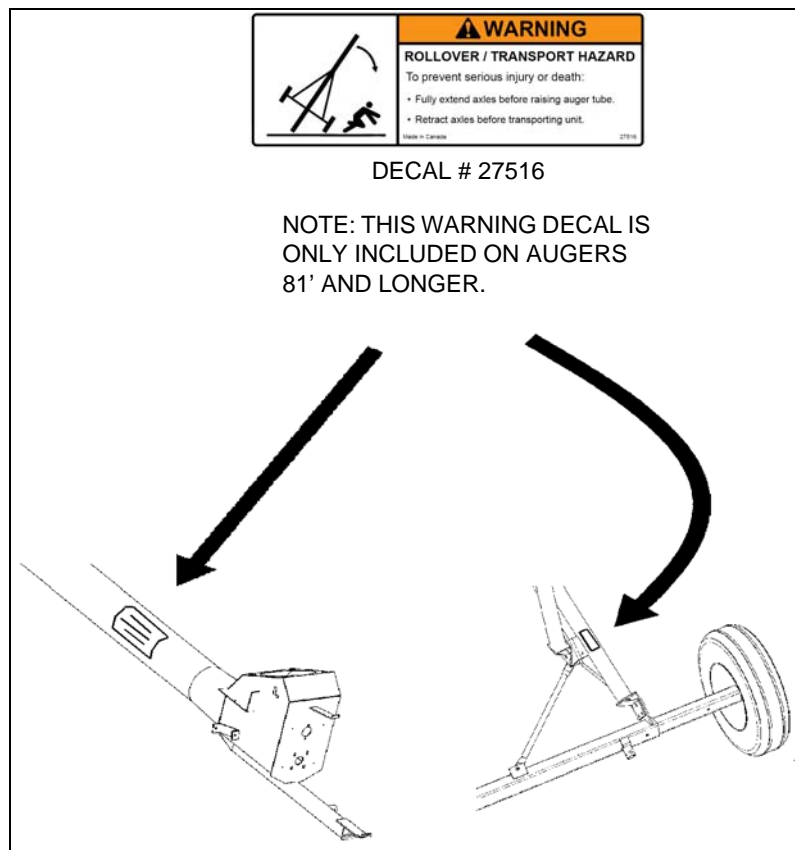

Figure 2.4





**Figure 2.5**



# 3. Assembly

**Warning:** Before continuing, please reread the safety information relevant to this section at the beginning of this manual. Failure to follow the safety instructions can result in serious injury, death, or property damage.

Before beginning assembly, familiarize yourself with all the sub-assemblies and hardware making up the auger. Have all parts on hand and arrange them for easy access. Carry out assembly in a large open area with a level surface.

**Important:** *Always have 2 or more people assembling the equipment. Because of the weight, do not attempt assembly alone.*

➔ Augers are available in various combinations. In most cases, the following instructions will apply to all augers. Where the assembly information varies, additional instructions will be included and will be indicated with an arrow.

## 3.1. TUBE AND FLIGHT

1. Position tube sections. Align tube sections on a flat surface or on a series of benches.

WARNING	
	Do not drop. Damage to equipment or serious personal injury will result.

- The MK130 Plus 61' has 3 tube sections.
- The MK130 Plus 71' has 4 tube sections.
- The MK130 Plus 81' has 4 tube sections.

**Important:** *Refer to Figure 3.12 and 3.13 for correct positioning. When assembling more than 2 sections, start from spout end and work towards hopper.*

2. Screw or slide lower flight shaft onto upper flight shaft until flight ends butt together and flighting spiral matches up. Secure with hardware listed in table below. Repeat, if necessary, for any remaining flight shafts.

- Slide tube sections together and secure. Make sure to align upper and lower track ends and then tighten bolts. Secure with hardware in table below.

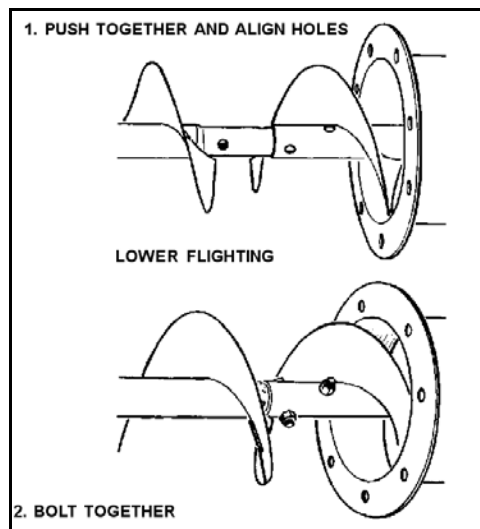

Figure 3.1

Details for fastenings:				
Auger	For Flighting	Amt	For Tubes	Amt
All	<ul style="list-style-type: none"> <li>5/8" x 4-1/2" GR8 bolts and locknuts</li> </ul>	2	<ul style="list-style-type: none"> <li>7/16" x 1-1/4" bolts and locknuts</li> </ul>	12

### 3.2. TRACK SHOE, TRACKSTOP, & LIFT-ASSIST ARM

- ➔ **MK130 Plus 61'/71'**: Slide the double roller track shoe onto track with cable attach-rod towards auger intake (Figure 3.2). Attach the angle trackstop as shown in Figure 3.3 using four 7/16" x 1-1/4" bolts and locknuts (see also Figure 3.12).

Auger	Track Stop
61'	<ul style="list-style-type: none"> <li>1st set of holes from top</li> </ul>
71'	<ul style="list-style-type: none"> <li>2nd set of holes from top</li> </ul>
81'	<ul style="list-style-type: none"> <li>set of 8 holes grouped together</li> </ul>

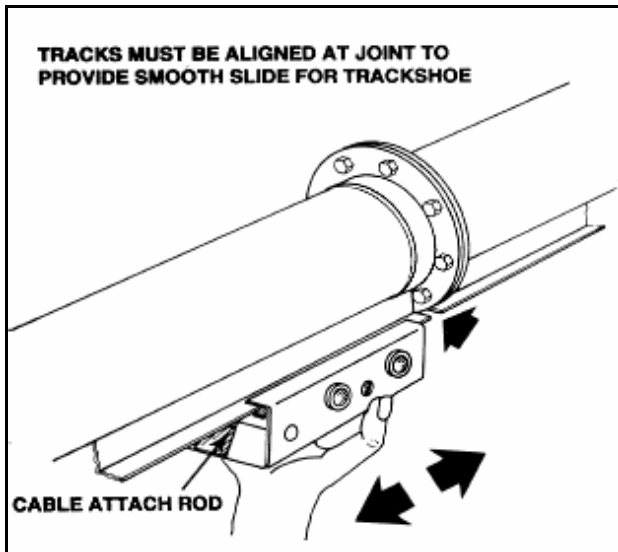

Figure 3.2

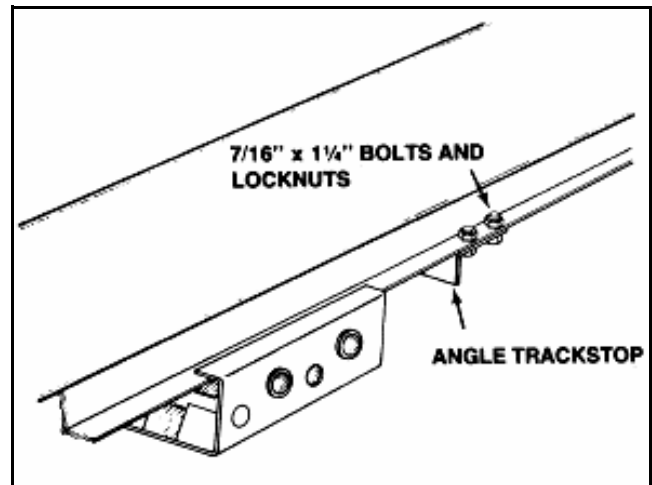

Figure 3.3

- ➔ 2. **MK130 Plus 81'**: the track shoe has 4 rollers (Figure 3.4) and the track stop is attached using 8 bolts and locknuts (Figure 3.5).

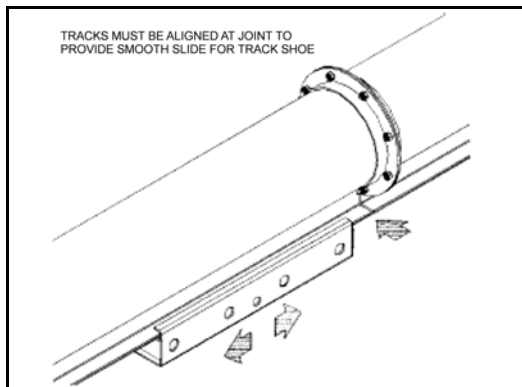

Figure 3.4

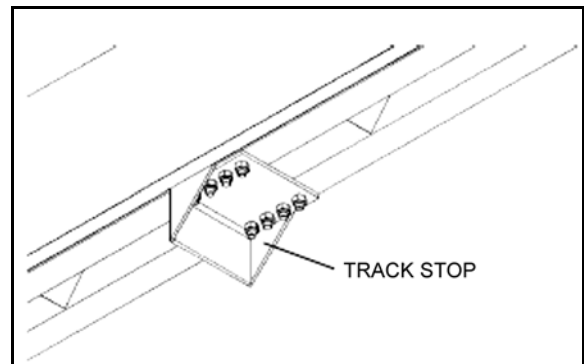

Figure 3.5

- ➔ 3. **MK130 Plus 61'**: attach the flat iron track stop to lower end of track with two 7/16" x 1-1/4" bolts and locknuts (Figure 3.6).
4. Slide track shoe along full length of track to make sure there is no binding and that track ends are properly aligned.

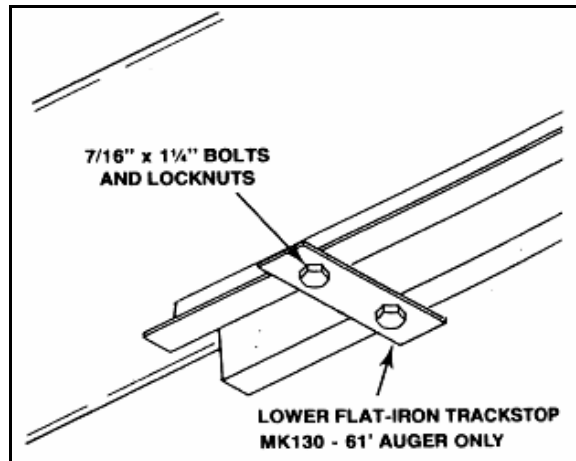

Figure 3.6

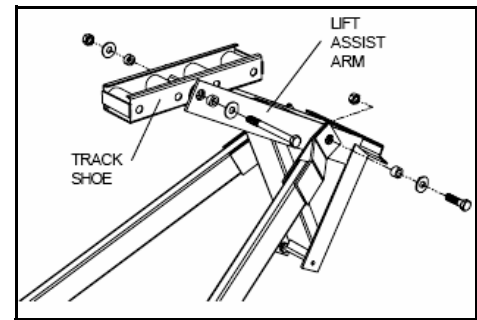

Figure 3.7

- ➔ 5. **MK130 Plus 81'**: attach the lift-assist arm to the center hole on the track shoe with an 11/16" short spacer and flat washer on each side and a 1" x 10" bolt and locknut. **Tighten securely** (Figure 3.7).

### 3.3. TOW BAR

- ➔ *The MK130 Plus auger has an adjustable tow bar. The tow bar is installed as seen in Figure 3.8.*

1. Insert the tow bar into the boot channel. Secure with a 3/4" x 6-1/2" long bolt and locknut through the back hole in the boot channel, under the boot.
2. Insert a 5/8" x 4-1/2" long bolt and locknut vertically into the hole at the front of the boot so that the towbar comes straight out of the boot.
  - This bolt must be inserted from the bottom with the nut on top.

**Note:** *The tow bar can be adjusted if a speed reducing gearbox is used with the system. In this case, the tow bar is extended and pinned on an angle using the vertical bolt. This will line up the PTO with the PTO connection on the gearbox.*

3. Install the PTO cradle bracket on the boot. Attach bracket with two 7/16" x 1-1/4" bolts and locknuts.

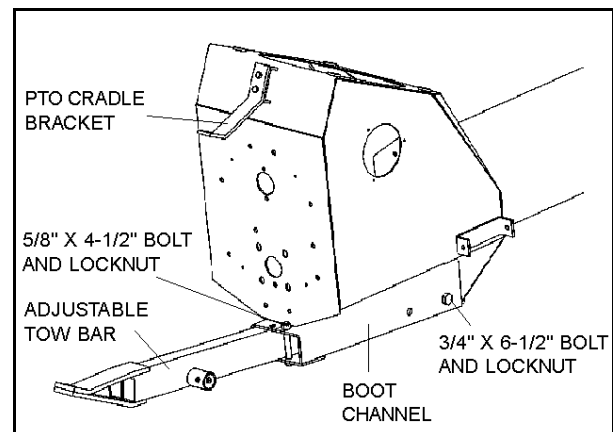

Figure 3.8

## 3.4. BOOT

**Note:** *The gearbox is sent from the factory filled halfway with EP90 oil. Before further assembly, check oil level to make certain the gearbox is half full. Add oil if necessary. Do not use grease.*

**Important:** *Complete assembly in the order listed to prevent premature failure of the lower bearing.*

1. Remove lower bearing from boot assembly.
2. At upper end, loosen set screw and remove lock collar from upper bearing.
3. Slip boot over lower flight shaft and attach to flange on lower tube. Tighten securely.
4. Slide the wide rim flat washer onto lower flight shaft.
5. Seat flight shaft shoulder against washer and lower bearing. Secure lock collar and tighten set screw on lower bearing.

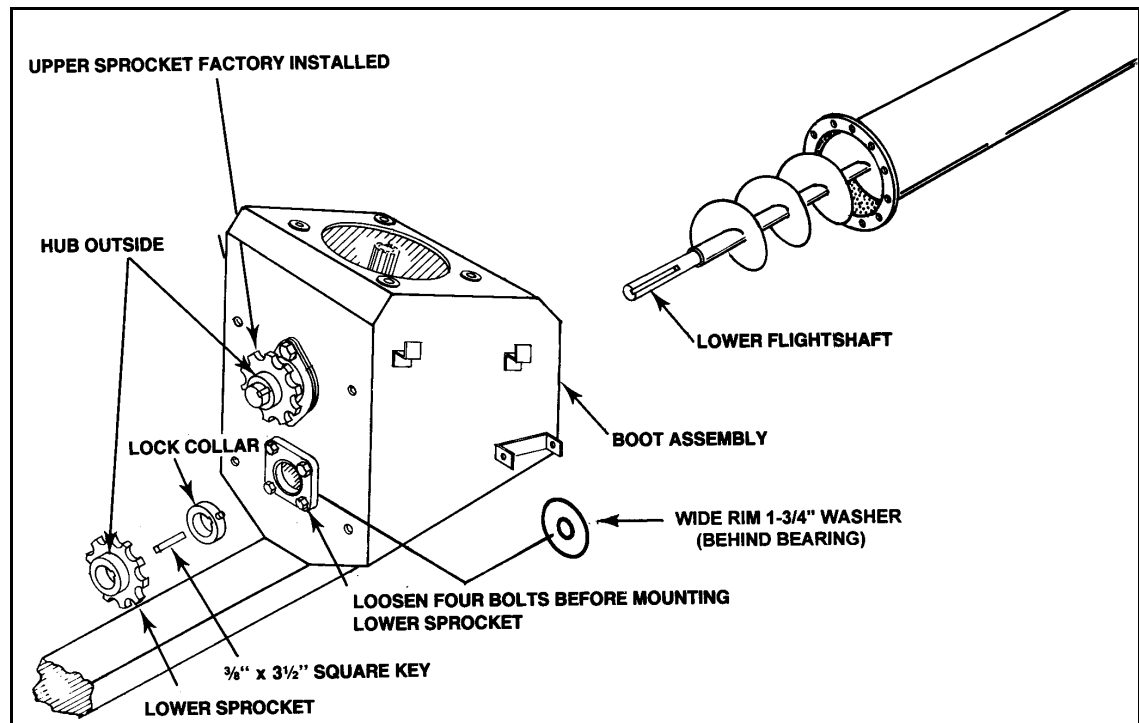

**Figure 3.9**

6. Slide short flight section onto lower flight shaft and secure. Make sure flight ends butt together and spiral matches up.

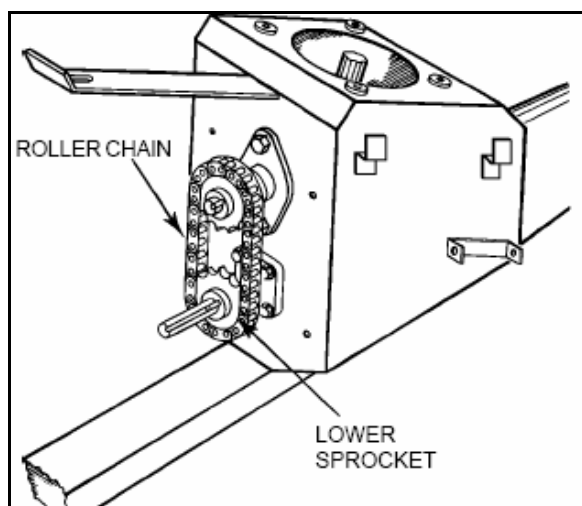

Figure 3.10

Part	Hardware	Amt
To attach boot to flange	• 7/16" x 1-1/4" bolts and locknuts	11
Wide rim flat washer	• 1-3/4"	1
Square key	• 3/8" x 3-1/2"	1

### 3.5. DISCHARGE SPOUT

Attach discharge spout with 7/16" x 1-1/4" bolts and locknuts (Figure 3.11).

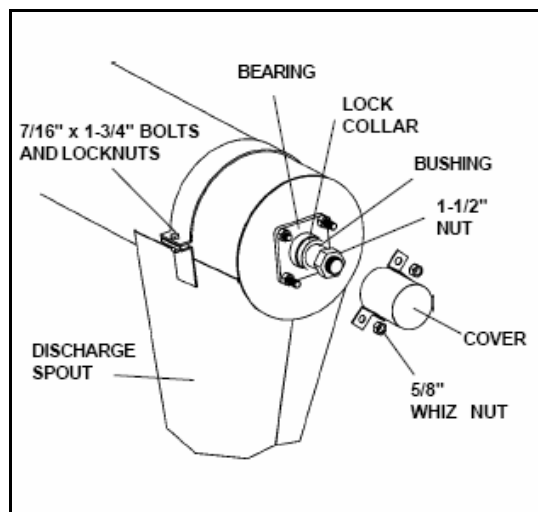

Figure 3.11

### 3.6. THRUST ADJUSTER

See Figure 3.11.

Thrust adjustment transfers some of the pressure from the lower flight bearing to the upper flight bearing.

1. Remove the upper bearing lock collar (if necessary).
2. Slide the lock collar and bushing onto the shaft and attach the 1-1/2" nut.
3. Turn the nut until it is snug against the bushing, then turn it so that the shaft moves an additional 1/4".



4. Secure the lock collar and tighten the set screw.
5. Install the cover over the two longer 5/8" bolts. Secure with two 5/8" whiznuts.

## 3.7. TRUSS

---

See Figure 3.12, 3.13, and 3.14.

**Note:** *Two 3/8" cable clamps are supplied to secure truss cables to the eyebolts as described below. Refer to Figure 3.12 on page 26. All other applications require 5/16" cable clamps.*

1. Fasten lower truss anchor to bracket.
  - use two 7/16" x 1-1/4" bolts and locknuts on the bracket welded to the lower tube
2. Fasten two truss-support brackets to the correct position on the auger tubes with two each 7/16" x 1-1/4" bolts and locknuts (Figure 3.12, 3.14).



*The 71' and 81' augers require a high truss support center bracket located between the 2 standard support brackets. Fasten with two 7/16" x 1-1/4" bolts and locknuts (Figure 3.12, 3.13).*

3. Attach eyebolt to one end of truss cable with a cable clamp. Insert eyebolt into lower truss anchor and thread on nut a short way.
4. Pull truss cable over truss support brackets, around upper truss anchor and back over truss support brackets to lower truss anchor, holding it loosely in place with one 5/16" cable clamp at upper truss anchor, and two 5/16" cable clamps at each truss support bracket.

**Important:** *Do not tighten cable clamps at this time.*

**Important:** 5. The upper end of augers equipped with truss cables should have an upward bow before being placed on the transport undercarriage (auger tube will straighten when fully assembled). Place supports under the discharge end until upward bow is correct.

- the upward bow should be about 3" on the 61' auger, 5" on the 71' auger, and 6"–7" on the 81' auger
6. Place other eyebolt onto lower truss anchor and thread on nut a short way.
  7. Insert other end of truss cable through this eyebolt. Pull out all slack and secure with two cable clamps.
    - use a 3/8" cable clamp
  8. Tighten eyebolts to take remaining slack out of truss cable and to maintain the appropriate upward bow. After tension is adjusted, tighten cable clamps on truss support brackets and upper truss anchor. Check for proper side alignment.

**Important:** *Once auger is fully assembled, adjust truss cables on all units (because of initial stretching). Cables may also require adjustment for side alignment.*

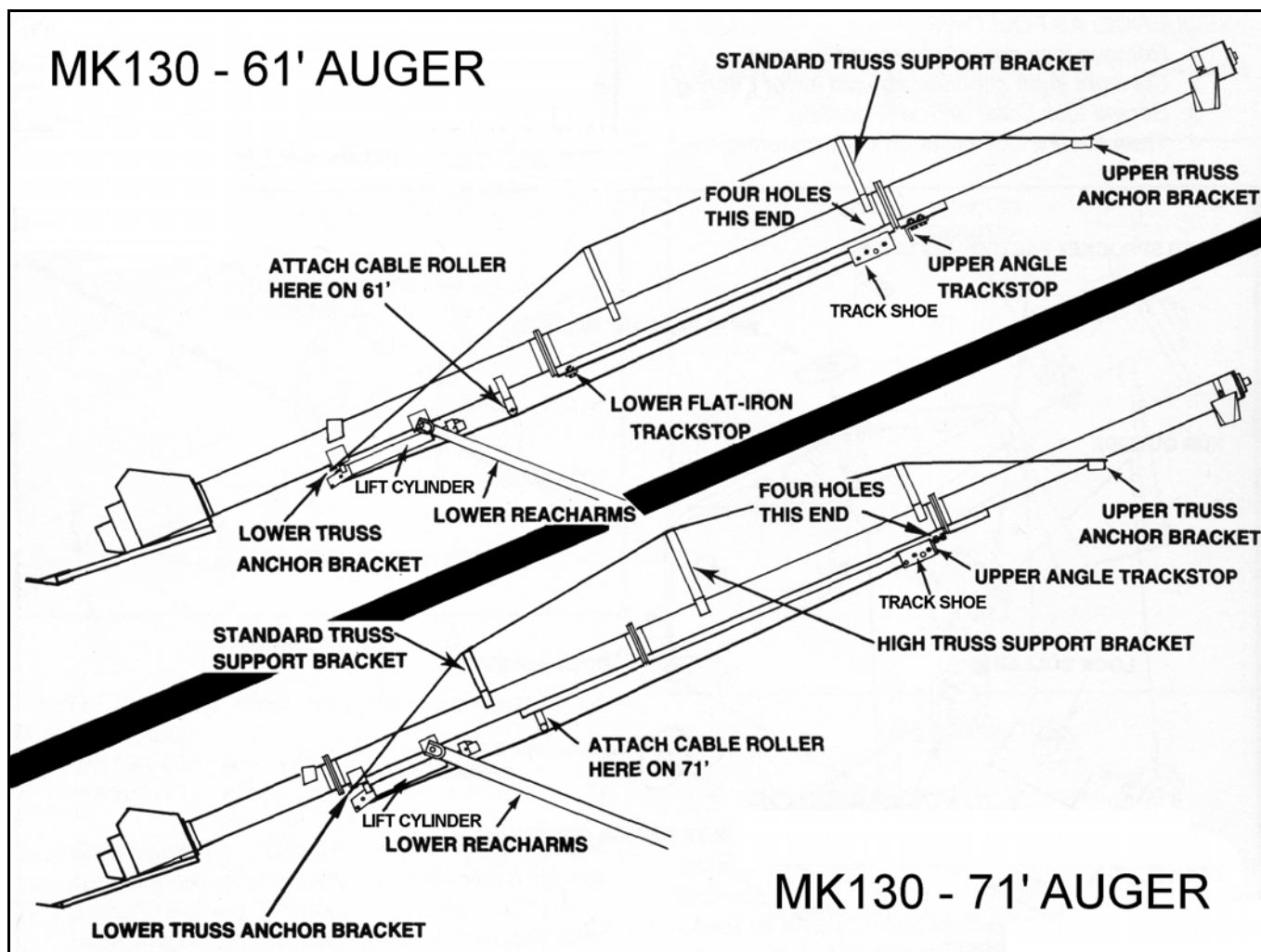

Figure 3.12 MK130 Plus 61' & 71'

- ➔ 9. **MK130 Plus 81'** (Figure 3.13):
- Fasten short truss anchor (A) to lower auger tube with 7/16" x 1" bolts and locknuts.
  - Fasten high truss support bracket to mount (C) on bottom of center tube with 7/16" x 1" bolts and locknuts.
  - Attach eyebolt to one end of truss cable with two 5/16" cable clamps, then insert eyebolt into short truss anchor and thread on nut a short way.
  - Pull truss cable over truss support bracket, around upper truss anchor (B) and back over truss support bracket to short truss anchor, holding it loosely in place with one cable clamp at upper truss anchor and 2 cable clamps at truss support bracket.
  - Place other eyebolt into short truss anchor and thread nut on a short way.
  - Insert other end of truss cable through this eyebolt. **Pull out all slack** and secure with two 5/16" cable clamps.
  - Tighten eyebolt to take remaining slack out of truss cable and adjust tension to keep auger tube straight. Tighten cable clamps on truss support bracket and upper truss anchor.

**Important:** Once auger is fully assembled, adjust truss cables on all units (because of initial stretching). Cables may also require adjustment for side alignment.

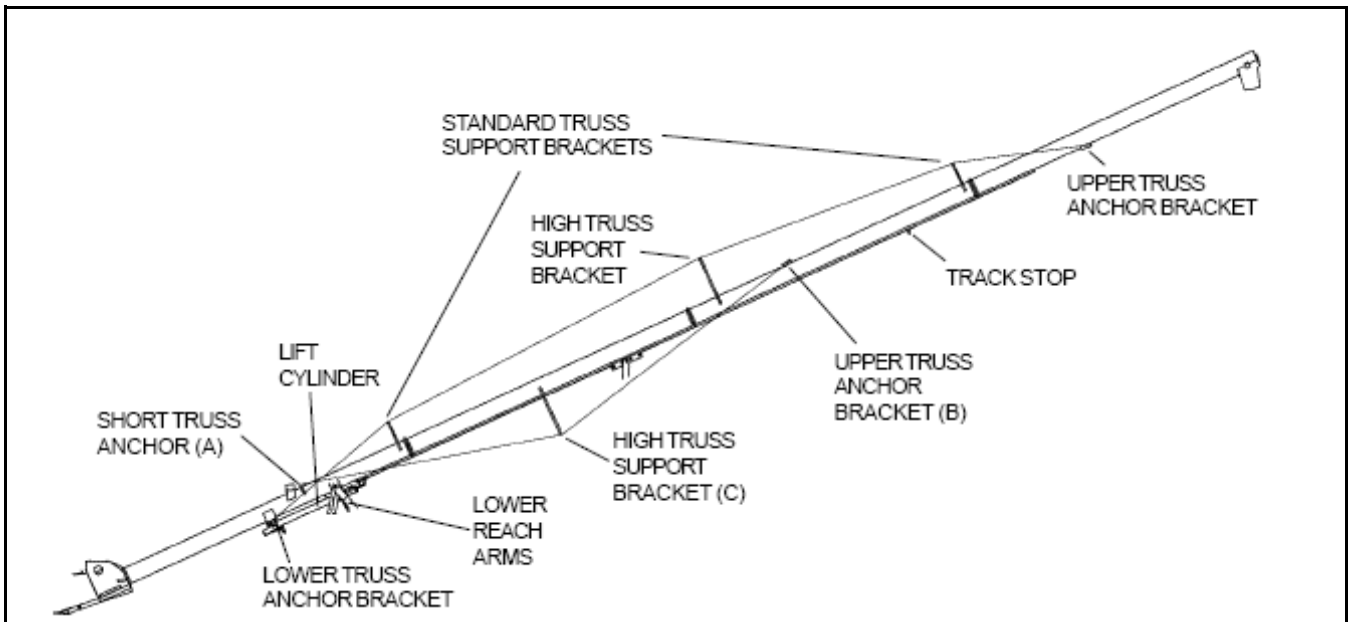

Figure 3.13 MK130 Plus 81'

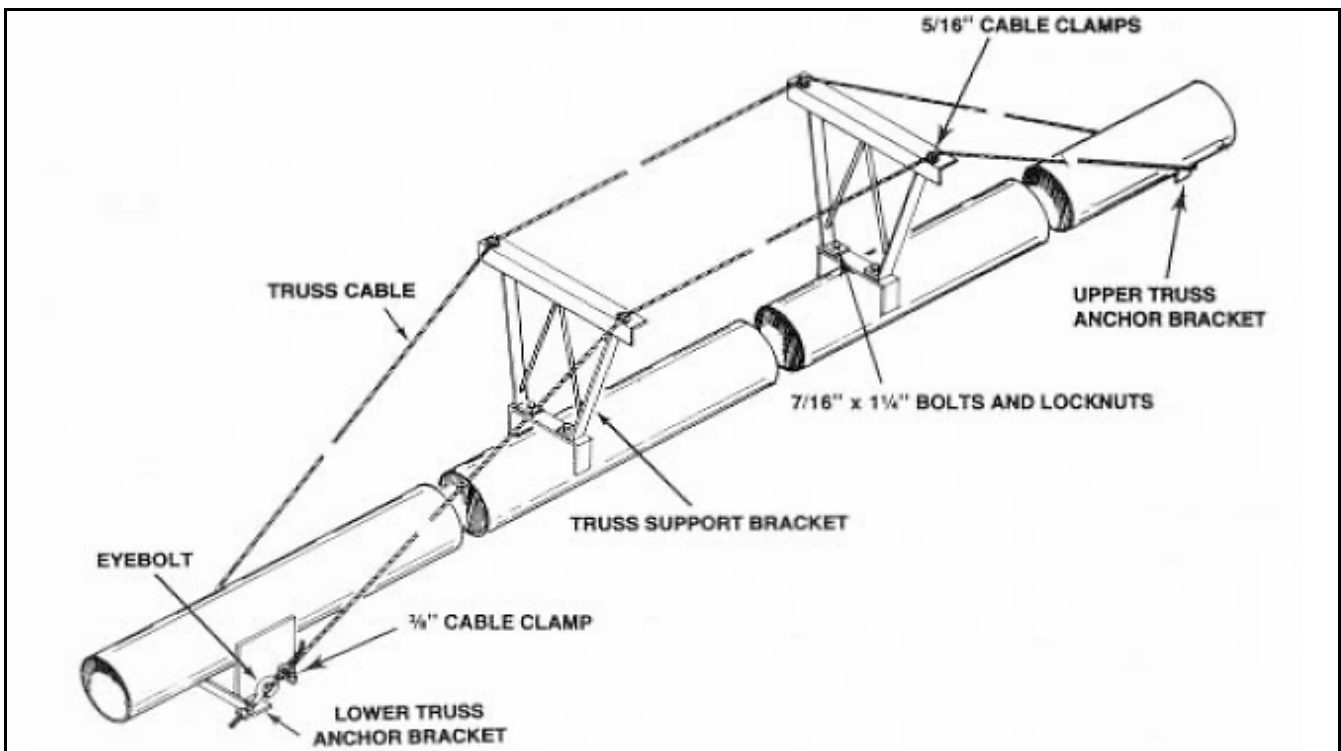

Figure 3.14 All Augers

## 3.8. TRANSPORT UNDERCARRIAGE

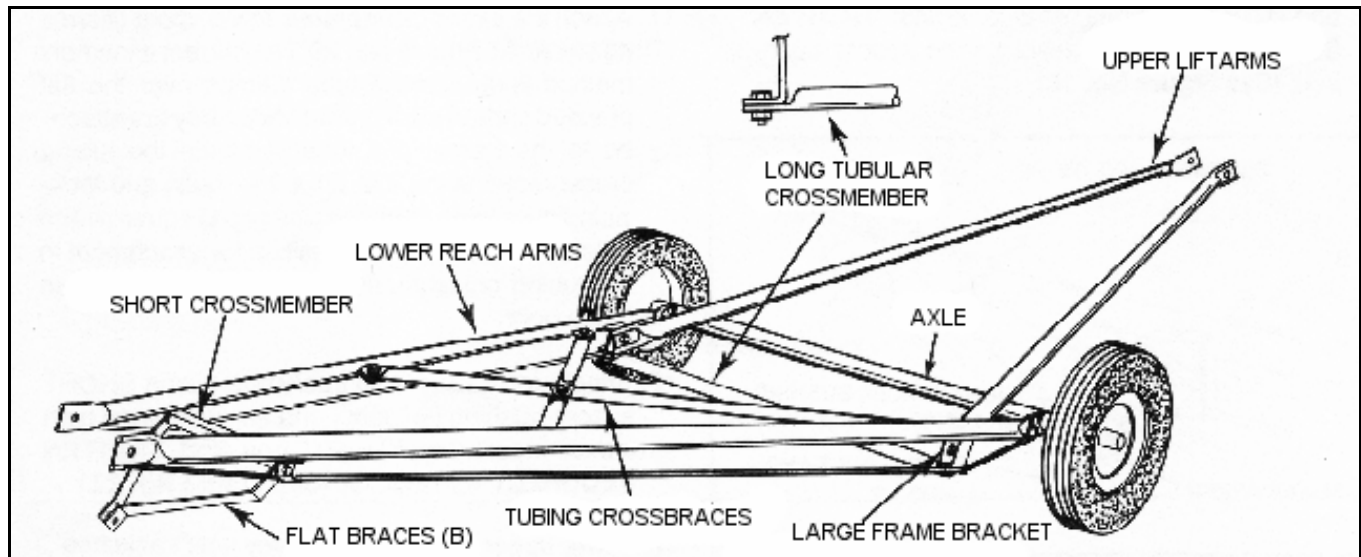

Figure 3.15 MK130 Plus 61'/71'

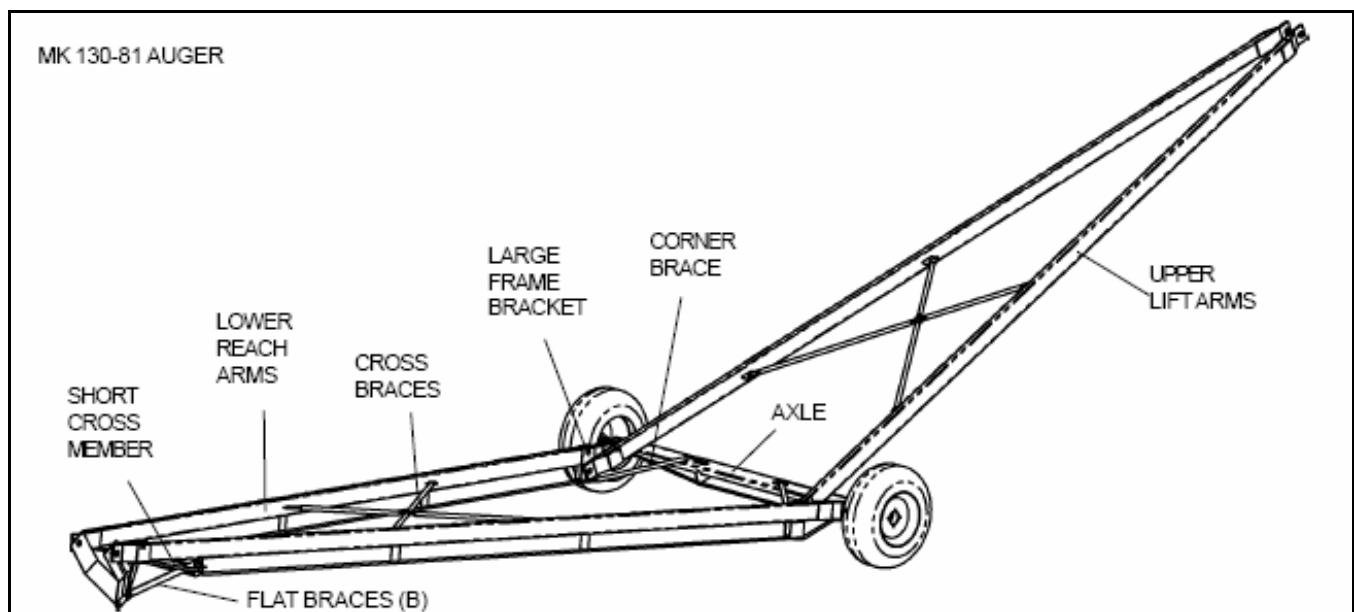

Figure 3.16 MK130 81'

1. Fasten the lower reach arms to the axle with three 5/8" x 2" bolts and locknuts on each side.
2. Attach long crossmember to bottom of large frame brackets (Figure 3.16) with two 5/8" x 1-1/2" bolts and locknuts.



*The MK130 Plus 81' auger does not have a long tubular crossmember. Instead, install 2 corner braces as seen in Figure 3.16.*

3. Loosely attach short channel crossmember to small frame brackets with two 5/8" x 2" bolts and locknuts, sandwiching the flatbraces (B) between the short crossmember and small frame brackets on each side (Figure 3.16). Leave loose until step 8.

4. Secure the tubing crossbraces to the welded lugs on the lower reach arms with four 1/2" x 1-1/4" bolts and locknuts, and a fifth one where the braces cross. Tighten securely.
5. Wheel hub assembly:
  - a. Remove any dirt or paint from spindle and hub.
  - b. Thoroughly pack wheel bearings and cups with a good grade of bearing grease.
  - c. Place large bearing into hub and carefully tap in seal.
  - d. Slip hub onto spindle and insert small bearing.
  - e. Tighten slotted spindle nut until hub drags slightly. Back off nut about 1/4 turn until hub turns freely.
  - f. Install cotter pin and dust cap.

**Note:** *Installing tires may not leave you with enough clearance to position and attach undercarriage once auger tube is raised. If so, install wheels after assembly is complete.*

- g. Install tires and tubes on the rims provided. Inflate according to recommendation on tire side-wall. Wheels may be mounted on hubs at this time with six 1/2" x 1-3/4" wheel bolts.

6. Fasten upper lift arms to lower reach arms using two short spacer bushings (3/4" long), flat washers, and 1" x 3-1/2" bolts and locknuts. **Tighten securely.** Lift arms pivot on the spacer bushings (Figure 3.18).

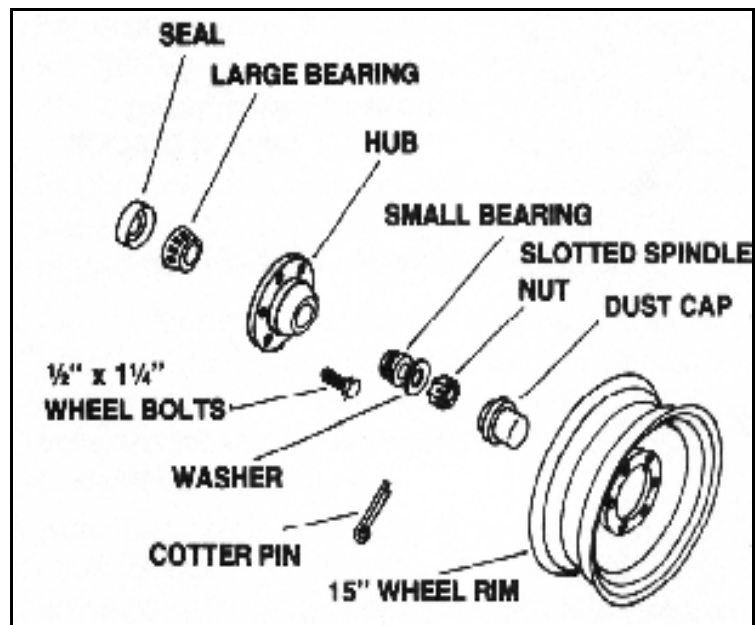

Figure 3.17

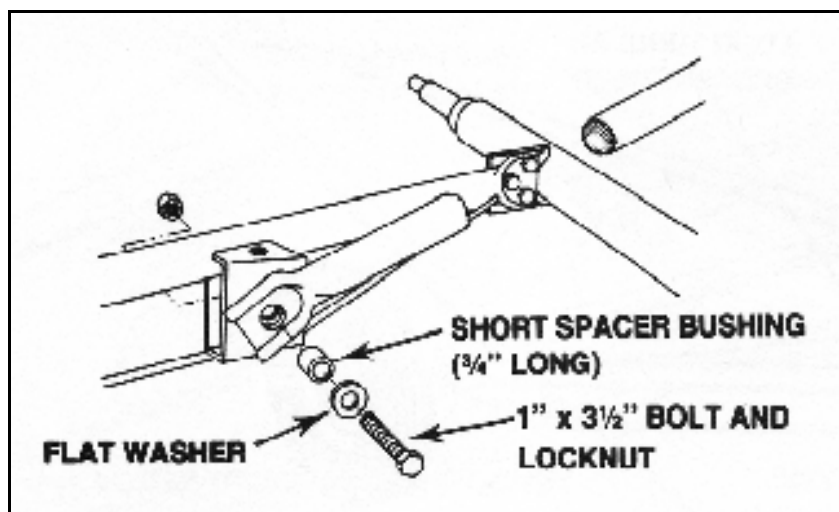
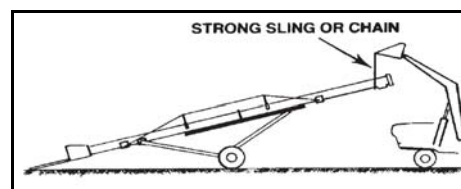

Figure 3.18

7. Raise the discharge end of auger with a front end loader and a strong sling/chain or block and tackle. The height should be sufficient to clear undercarriage assembly.

**WARNING**

Do not remove tube support until the assembly in this section has been completed.

8. Place undercarriage beneath tube assembly.
9. Position stabilizer braces (A) (Figure 3.19) and attach lower reach arms to bracket on tube with long spacer bushings (1" long), flat washers, and 1" x 3-1/2" bolts and locknuts. **Tighten securely.** Reach arms pivot on the spacer bushings.

**Important:** Refer to Figure 3.12 for correct placement of lower reach arms.

10. Fasten flat braces (B) to first set of holes (furthest from intake) on stabilizer braces (A) with one 5/8" x 2" bolt and locknut. Place one 5/8" x 1-1/2" bolt and locknut in other hole of stabilizer brace.
11. Attach the tubing crossbraces to the upper lift arms (Figure 3.19) by slipping the tube clamps over the flat pressed ends of the lift arms (where they are attached to the frame) and loosely attaching the tubing crossbraces using five 1/2" x 1-1/4" bolts and locknuts.
  - Use a large c-clamp vise grip to squeeze and hold the tube clamps in position for attachment of the tubing crossbraces.
  - Once in position, tighten these bolts.

➔ The **MK130 Plus 81'** auger does not use tube clamps. The attach tabs are welded onto the upper reach arms.

- ➔ 12. **MK130 Plus 61'/71'**: attach upper lift arms to track shoe. Use a short spacer bushing (3/4" long) and flat washer on both sides; insert the 1" x 10" bolt and **tighten securely** with locknut (Figure 3.19).

- ➔ 13. **MK130 Plus 81'**: attach upper lift arms to the center hole on the lift-assist arms as shown in Figure 3.25 using two 5/16" medium spacers, flat washers, and two 1" x 3-1/2" bolts and locknuts. **Tighten securely.** The lift arms will pivot on the spacer bushings.
- 14. Lower upper end of auger slowly until track shoe rests against upper track stop.
- ➔ *The MK130 Plus 81' lift-assist will rest against the track.*

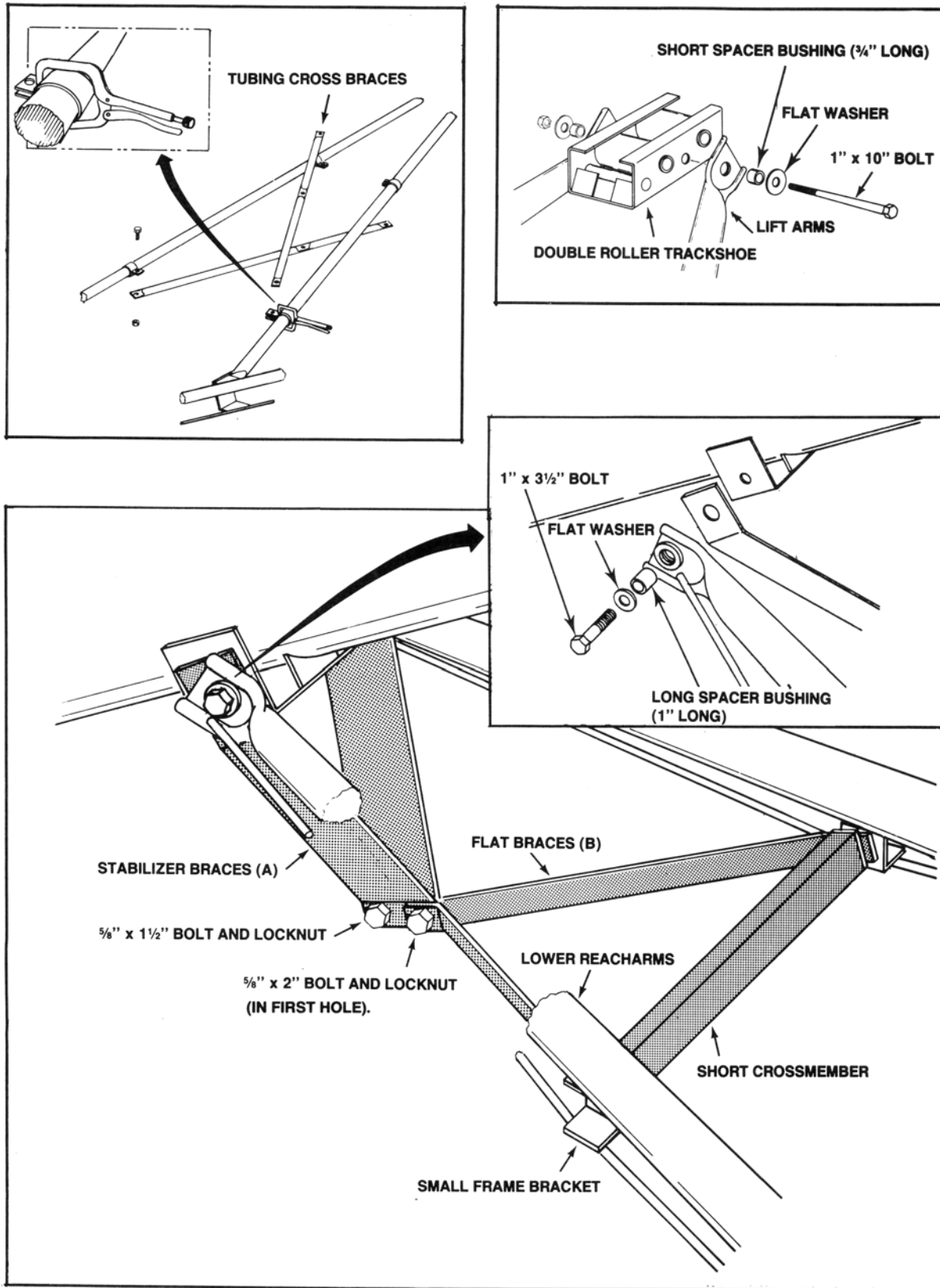

Figure 3.19



## 3.9. LIFT CYLINDER / CABLE

### 3.9.1. MK130 PLUS 61'/71'

**Note:** Determine right or left side of auger by standing at intake end facing top discharge end.

1. Position one of the lift cylinders to the right side of welded brackets on the lower end of auger tube (see Figure 3.12 for correct position). Attach with four 7/16" x 1-1/4" bolts and locknuts. Tighten securely.

**Note:** Cylinder must be positioned with ram end towards discharge end of auger.

2. Rotate the elbow fitting at lower end of lift cylinder so it faces down, making sure it is securely tightened (Figure 3.20).
3. Secure the solid connector end of the short cylinder connector hydraulic hose to above elbow fitting on right side lift cylinder. Use thread sealant (not supplied). The other end of this short hose is secured later.

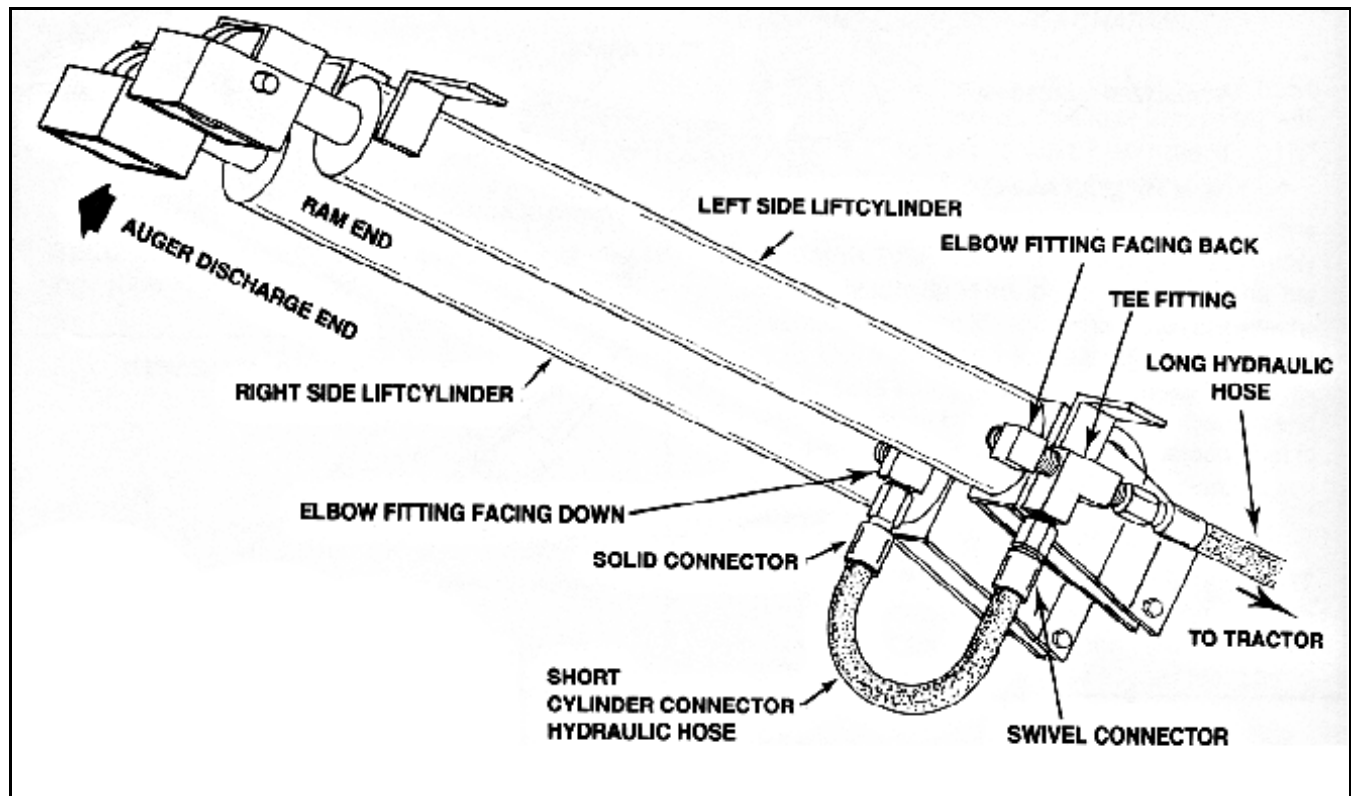



Figure 3.20

- Attach other lift cylinder to left side of welded bracket with four 7/16" x 1-1/4" bolts and locknuts. Tighten securely (see Figure 3.12 for correct position).

<b>CAUTION</b>	
	<p>Track shoe must rest against track stop when adjusting cable.</p> <p>If this isn't done, the auger can raise higher than designed to lift, resulting in damage to auger and possible injury to personnel.</p>

**Note:** *Although the lift cable is factory installed on the cylinder, make sure that the cable clamps on the cylinder are secure and the cables are properly seated in the cable sheaves before attaching the cable to the track shoe.*

- With both cylinders in full down position and track shoe resting against the track stop, thread both cables over the cable-attach-rod on the track shoe. Pull cable very tight, then secure with three 5/16" cable clamps on each cable, positioned as shown (Figure 3.21). Tighten securely. Tie up excess ends of lift cable with tape or ty-wrap.

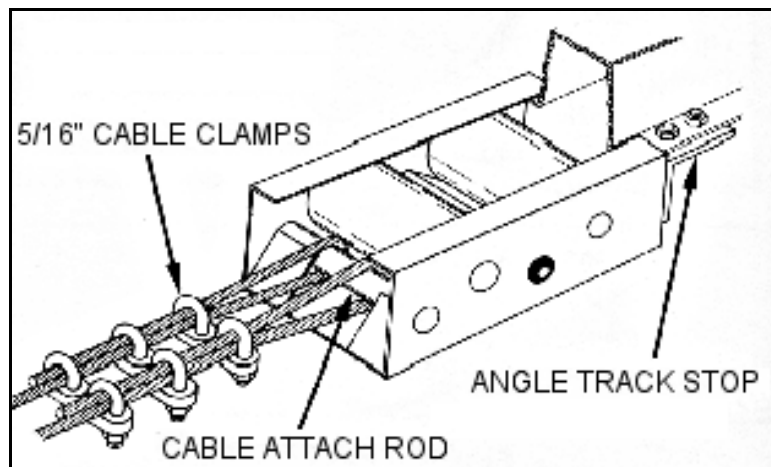

**Figure 3.21**

**Important:** *Lift cable will stretch with initial use. Check frequently and adjust.*

- Attach the cable-roller to the appropriate location with two 7/16" x 1-1/4" bolts and locknuts (Figure 3.25).

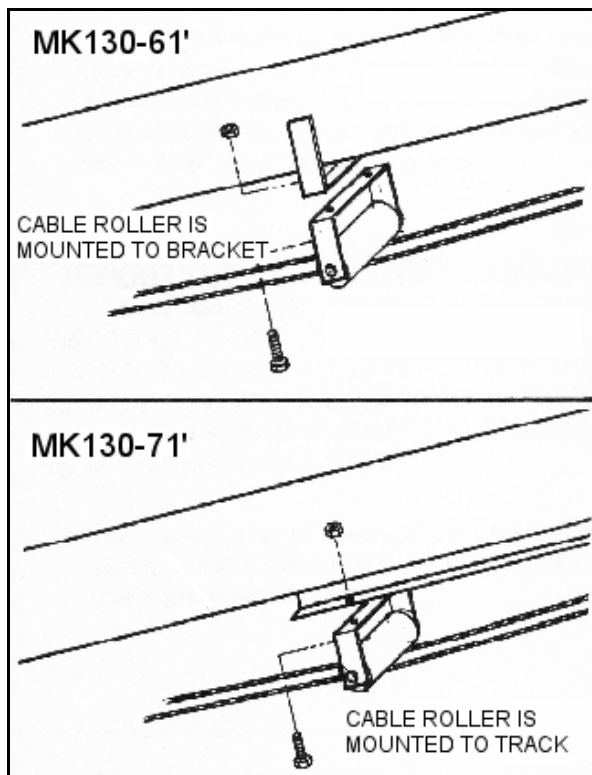
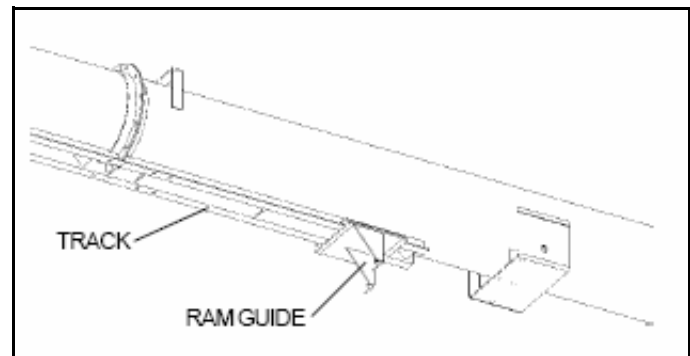

**Figure 3.22**

- ➔ • **MK130 Plus 61'**: attach the cable-roller to bracket located between lower end of track and lift cylinder (Figure 3.12).
- ➔ • **MK130 Plus 71'**: attach the cable-roller to lower end of track (Figure 3.13).

### 3.9.2. MK130 PLUS 81'

1. Slide ram guide onto track (Figure 3.23).
2. Position one of the lift cylinders to the right side of the welded brackets on the lower end of auger tube (Figure 3.13). Attach with four 7/16" x 1-1/4" bolts and locknuts. Tighten securely.

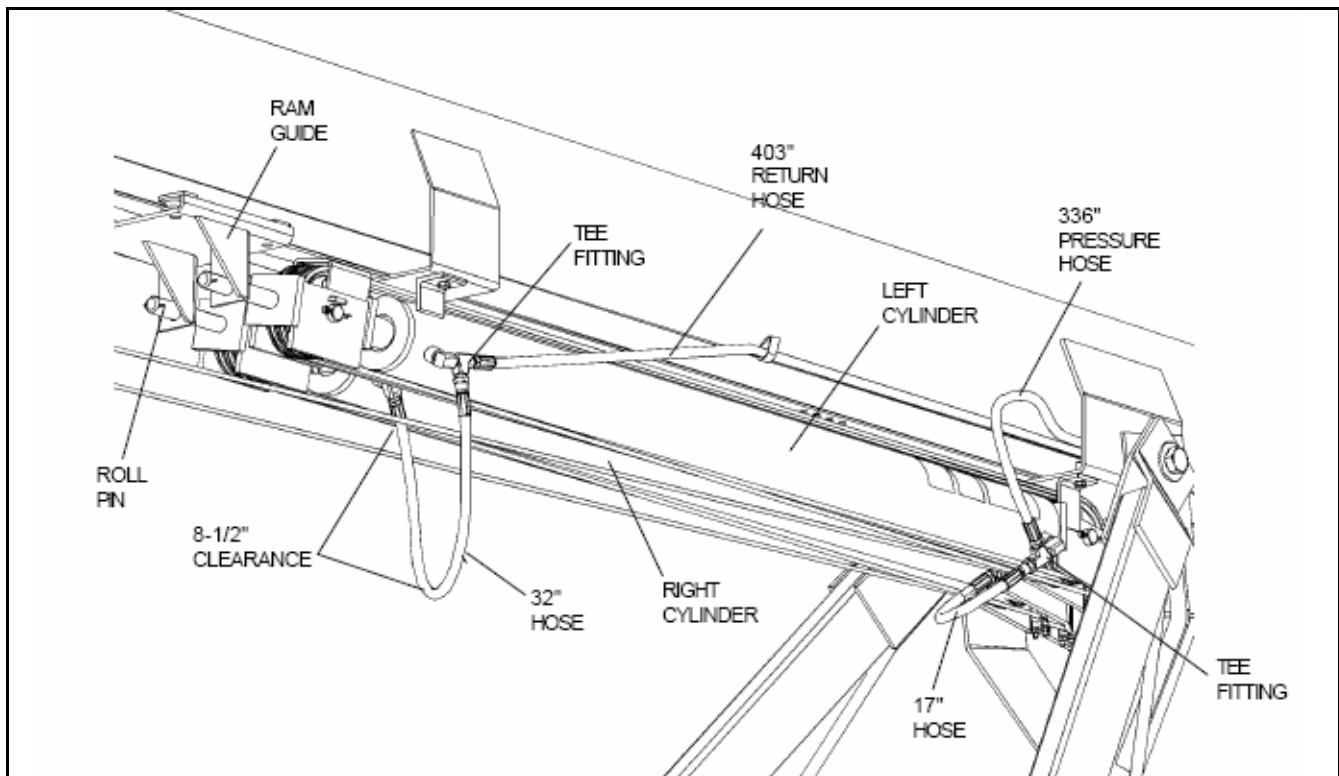

**Figure 3.23**

**Note:** *Cylinder must be positioned with ram end towards discharge end of auger.*

3. Attach other lift cylinder to left side of welded bracket with four 7/16" x 1-1/4" bolts and locknuts. Tighten securely (Figure 3.13).

4. Insert the ram ends into brackets on ram guide (Figure 3.24). Secure with two roll pins.

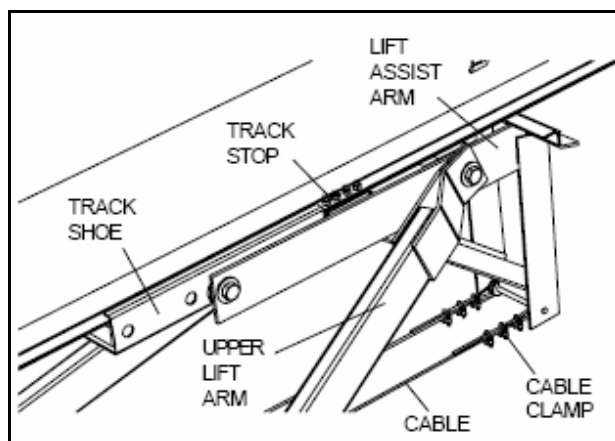

**Figure 3.24 MK130 Plus 81'**

5. Seat lift-assist arm against the track and place both lift cylinders in full down position (fully retracted).

**Important:** *Lift cables may stretch with use. Check frequently and adjust when necessary.*

6. Thread the lift cables over the respective pulleys on the lift-assist arm, pull cables tight, and secure with 3 cable clamps. Tighten securely. Do not crisscross cables (Figure 3.25).



**Figure 3.25**

**Note:** *Although the lift cables are factory installed on the lift cylinders, make sure the cable clamps on the cylinders are secure and the cables are properly seated in the cable sheaves before attaching the cables to the lift-assist arm.*

CAUTION	
	<p>Track shoe must rest against track stop when adjusting cable.</p> <p>Failure to heed will allow auger to raise higher than designed to lift, resulting in damage to auger and injury to personnel.</p>

## 3.10. HYDRAULIC HOSES

---

**Note:** *Determine right or left side of auger by standing at intake end facing top discharge end.*

### 3.10.1. MK130 61'/71'

---

**Note:** *Elbow fittings are factory installed. Use thread sealant on fitting and hose threads (not supplied.)*

1. With elbow fitting on left side lift cylinder facing back as shown, secure the tee fitting to the elbow fitting (Figure 3.20).
2. Securely attach the swivel connector end of the short hydraulic hose to tee fitting on left side cylinder (Figure 3.20). Make sure that this short hose is **beneath** the lift cable on left side lift cylinder (Figure 3.26).

**Note:** *Before attaching short connector hydraulic hose to left side lift cylinder, make certain lift cables are tightly stretched and that this hose is positioned beneath lift cable on left side lift cylinder (Figure 3.26). If lift cable is not installed above this hose, it could result in the hose wearing through during operation, causing a hazardous condition.*

WARNING	
	<p>Wear on hose can cause auger to drop suddenly, causing serious injury or death.</p>

- Securely attach the long hydraulic hose to tee fitting (Figure 3.26). Place this hose into brackets welded to side of auger tube and boot. Bend tops of these brackets over slightly to hold hose in place.

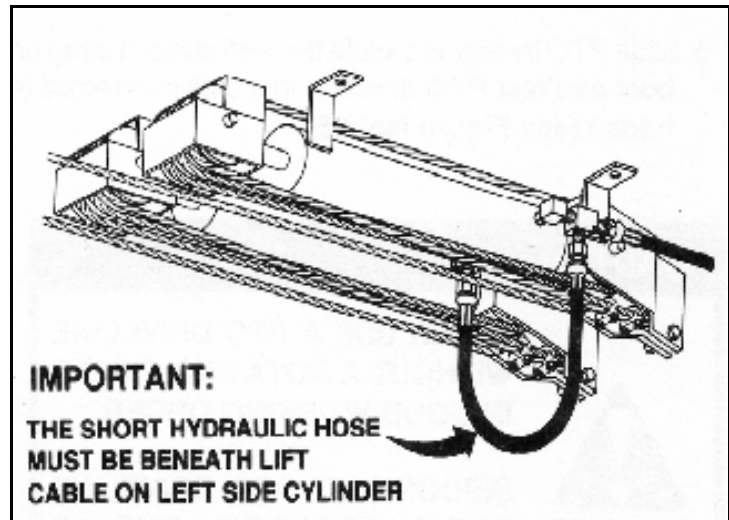

Figure 3.26

**Important:** *Protect hose ends from dirt.*

- Recheck that bolts on undercarriage, lift cylinders, and cable clamps are tight, then remove auger tube support.

### 3.10.2. MK130 81'

- **Lower** fittings refer to those closer to boot end of auger.
- **Upper** fittings refer to those closer to discharge end of auger.

**Note:** *Use thread sealant (not supplied) on hydraulic connections.*

- Position both elbow fittings on **right lift cylinder**. The **lower** one should face forward and downward at approximately 45°. The **upper** one should face rearward and downward at approximately 45° (Figure 3.24). Make certain they are tight.
- Secure the solid connector end of the short (17") cylinder-connector hydraulic hose to the lower elbow fitting.
- Secure the solid connector end of the long (32") cylinder-connector hydraulic hose to the upper elbow fitting.

**Note:** *Before attaching short connector hydraulic hose to left side lift cylinder, make certain lift cables are tightly stretched and that this hose is positioned beneath lift cable on left side lift cylinder (Figure 3.20). With lift cable beneath this hose, cable will wear on hose as auger is raised and lowered, causing hose to wear through.*

WARNING	
	<p>Wear on hose can cause auger to drop suddenly, causing serious injury or death.</p>

4. Position the elbow fittings on the **left lift cylinder**. The **lower** one should face forward and downward at approximately 45°. The **upper** one should face rearward and upward at approximately 10°.
5. Secure the tee fittings to the left cylinder elbow fittings and position them as shown in Figure 3.24. Make certain they are securely tightened.
6. Secure the swivel ends of the upper (32") and lower (17") cylinder-connector hoses to the tees as shown.
7. Check upper 32" cylinder-connector hose position to ensure there is 8-1/2" of clearance to lift cables as shown in Figure 3.24.
8. Attach the 336" long pressure hydraulic hose with shut-off valve to the lower tee fitting (nearest auger intake).
9. Attach the 403" return hydraulic hose without shut-off valve to the upper tee fitting (nearest auger discharge end).
10. Thread hoses through back arm attach bracket (Figure 3.24).
11. Place both hoses into retaining brackets welded to side of auger tube and boot. Bend tops of brackets over slightly to hold hoses in place.

**Important:** *Protect hose ends from dirt.*

12. Recheck that bolts on undercarriage, lift cylinders, and cable clamps are tight, then remove auger tube support.

## 3.11. PTO (CV) DRIVELINE

---

1. Clean PTO driveline and flighting shaft ends of any paint or dirt.
2. Slide plain end of PTO driveline onto flighting shaft. Make sure the holes for the roll pin are lined up and square key is in place (where necessary).
  - use 3/8" diameter holes for the 3/8" roll pin
  - the 3/8" x 3-1/2" square key should already be in place
3. Making sure eyes are protected, carefully tap in roll pin. Tighten set screw.
4. Install sprocket guard on boot with four 5/16" x 3/4" bolts.
5. Slide PTO transport saddle through support strap on boot and rest PTO driveline in it until connected to tractor.

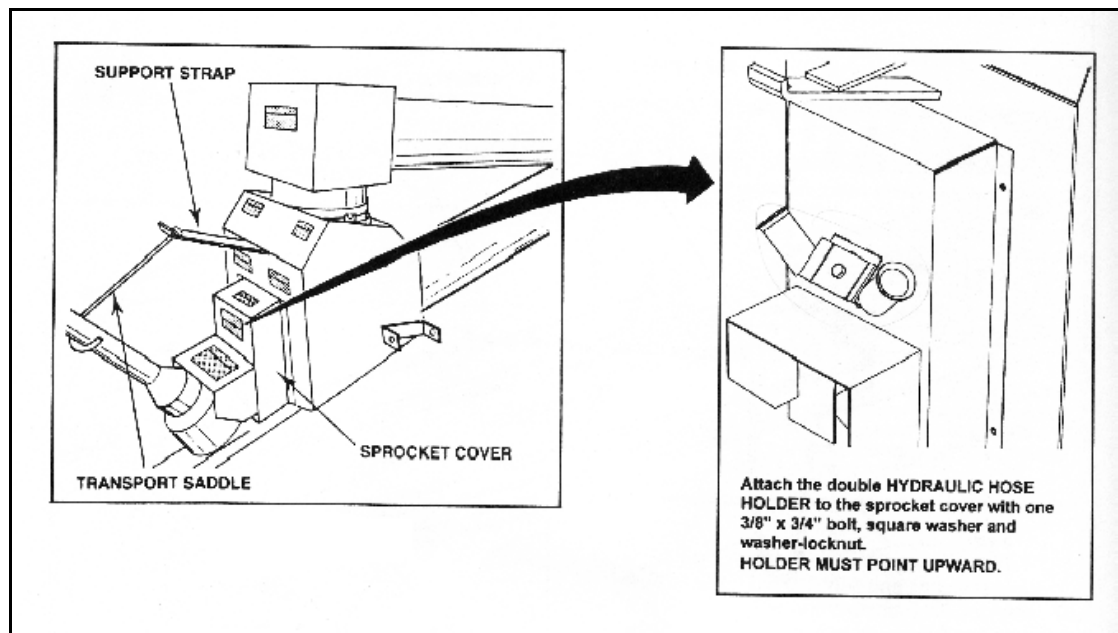

Figure 3.27

## 3.12. STANDARD INTAKE HOPPER

See Figure 3.28 and 3.29.

1. Remove access covers, then clean paint and dirt from flight shaft end. Insert Woodruff key into flight shaft end.
2. Raise hopper tube to correct angle<sup>1</sup> (22.5°) and then bring hopper and tube section together, carefully sliding the flight shaft end with Woodruff key into the angle drive.
3. Connect the hopper and tube section.
  - use eight 7/16" x 1-1/3" bolts and locknuts

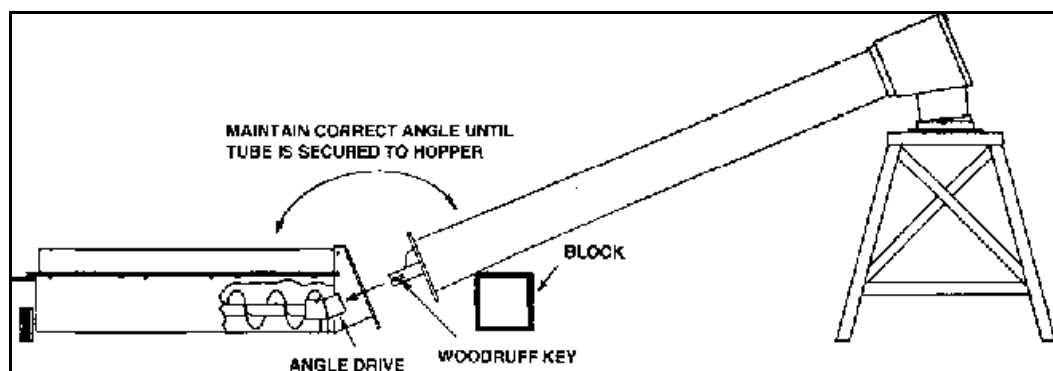

Figure 3.28

1. Correct angle is achieved when the flight shaft end is inserted in the angle drive and its weight is fully supported by the block and stand.



## NOTICE

To prevent damage, you must maintain the correct angle when inserting flight shaft end into angle drive until tube is secured to the hopper section. Allowing tube or hopper to drop will bend the flight shaft end causing it to bind in the angle drive.

4. Thoroughly lubricate the angle drive, then replace access doors. Keep angle drive well lubricated (after every 8 hours of operation) with high-temperature grease.

**Important:** Check alignment! You should be able to rotate the hopper flight by hand.

**Note:** The angle drive requires a break-in period of at least 2 to 3 loads.

5. Clean any dirt or paint from the wheel axles on the hopper bottom.
6. Install the 2 wheels to the hopper bottom with a washer and cotter pin each.

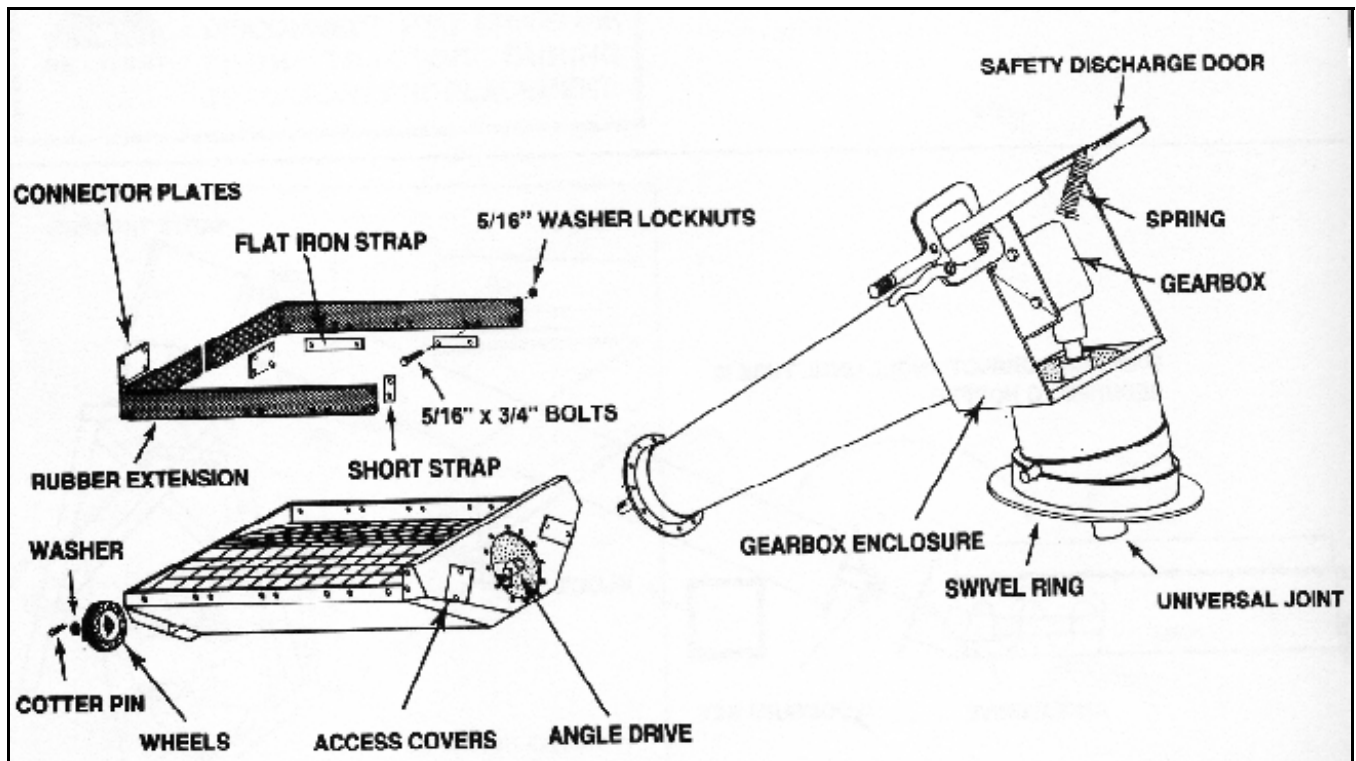
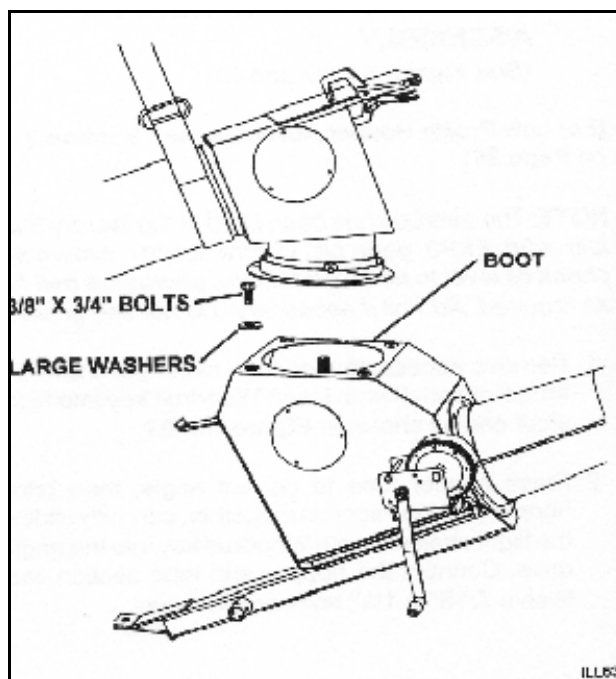
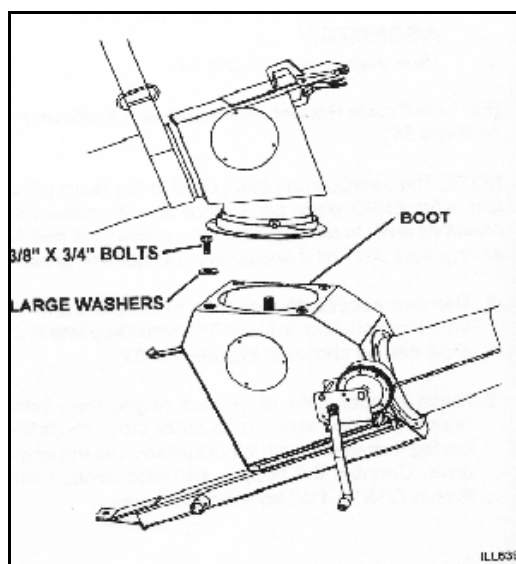

Figure 3.29

7. Install the 2 pieces of rubber extension on inside hopper lip with twenty  $5/16'' \times 3/4''$  bolts and washer locknuts, 10 long and 2 short flat iron straps, plus the 2-piece extension connector plates (Figure 3.29).
8. Open safety discharge door to connect intake hopper to auger boot.
  - This door is held in place internally with two springs. To open, pull the door down and then up and over the gearbox enclosure. Hold open with a C-clamp vise grip.
- a. Clean u-joint spline and lower gearbox spline, then apply a light film of grease on splined shaft.
- b. Guide splined universal joint onto splined shaft as the intake hopper is lowered onto the boot. Once positioned, the swivel ring rests flat on the boot surface and inside the four spacer nuts.
9. Install four large washers with  $3/8'' \times 3/4''$  bolts to keep the intake hopper in place on the boot.
10. Lubricate the universal joint and close the safety discharge door.



**Figure 3.30**



**Figure 3.31**

### 3.12.1. HOPPER LIFT EXTENSION

---

**AE MK100 81' only:**

1. Place the hopper lift extension onto the bracket on the lower tube as shown.
2. Secure by using the 2 lift extension brackets and four 7/16" x 1-1/4" bolts and locknuts.

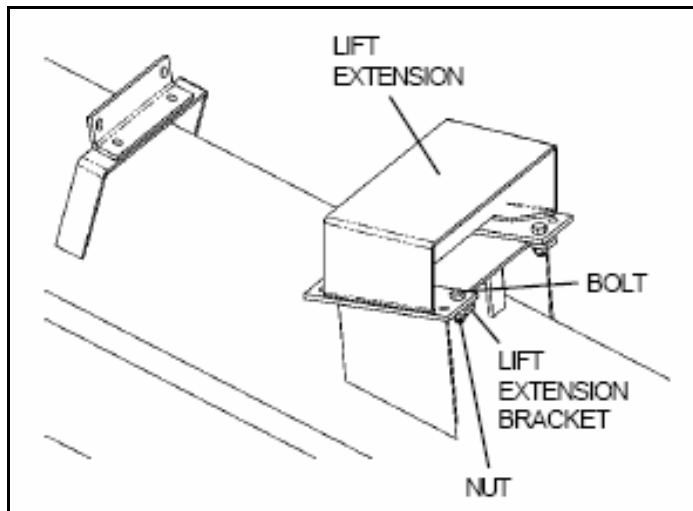
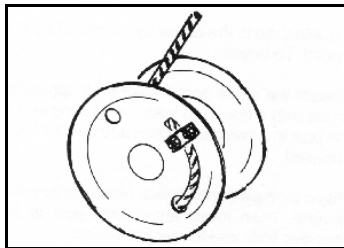

**Figure 3.32**

### 3.12.2. HOPPER LIFT ARM / WINCH

---

1. Choose either the right or left side; secure hopper lift arm assembly to the mount bracket on top of the lower auger tube with 2 mount pins and hairpin.
2. Thread cable through hopper lift arm assembly and attach to winch.



**Figure 3.33**

*Intake feed side of hopper must face main auger when in transport.*

3. Install winch and winch bracket assembly to auger boot (opposite to side of hopper operation) with a saddle pin and a hairpin.

#### **TO PLACE HOPPER INTO TRANSPORT POSITION:**

1. Attach cable hook to the loops inside the hopper.
2. Lock in transport position with the handles on the side of the hopper.
3. Fully raise hopper with intake side facing towards the main auger as shown.
4. Secure hopper to lift arm with the hopper lock, saddle pins, and hairpins provided.

**Note:** Winch shown is positioned to use hopper on right side of auger (as determined when standing at intake end facing discharge end). To position winch or left side hopper use, the winch with bracket must be attached with drum up, using the saddle pin with a hairpin.

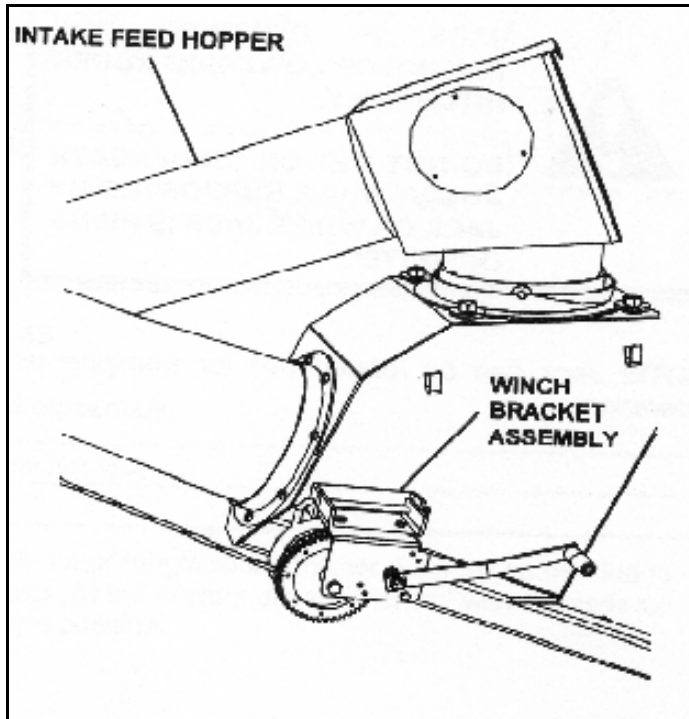

Figure 3.34

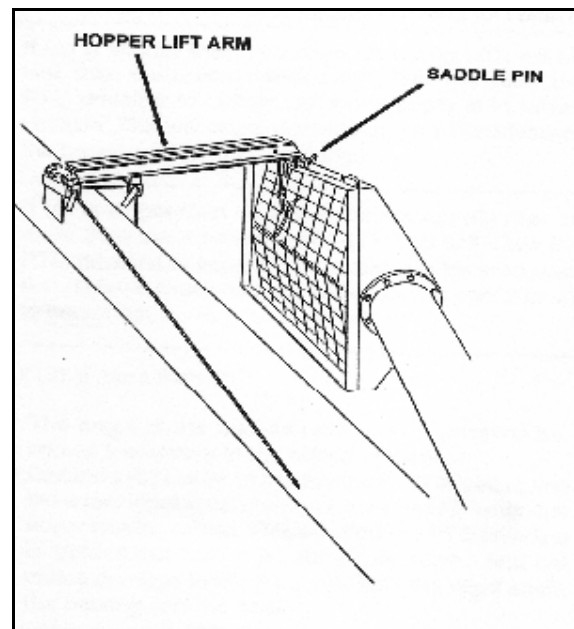

Figure 3.35

### 3.13. OPTIONAL LOW PROFILE HOPPER

See Figure 3.36–3.38.

1. Attach the pivot-connector to the appropriate holes in hopper with two 5/8" x 1-1/2" bolts and locknuts. **Do not over-tighten.** Tighten snug only; these bolts act as pivot points.
2. Loosely secure the service door with the 2 square latch-washers and 3/8" locknuts.

**Note:** *These must be tightened securely after hopper assembly is completed.*

3. Clean dirt from inside u-joint and flight shaft end, then insert Woodruff key.
4. Raise and support hopper tube at about 50" under spout.
5. Open service door on hopper, then bring tube and hopper together guiding flight shaft into u-joint.
6. Secure tube to pivot-connector on hopper.
  - use 7/16" x 1-1/4" bolts and locknuts

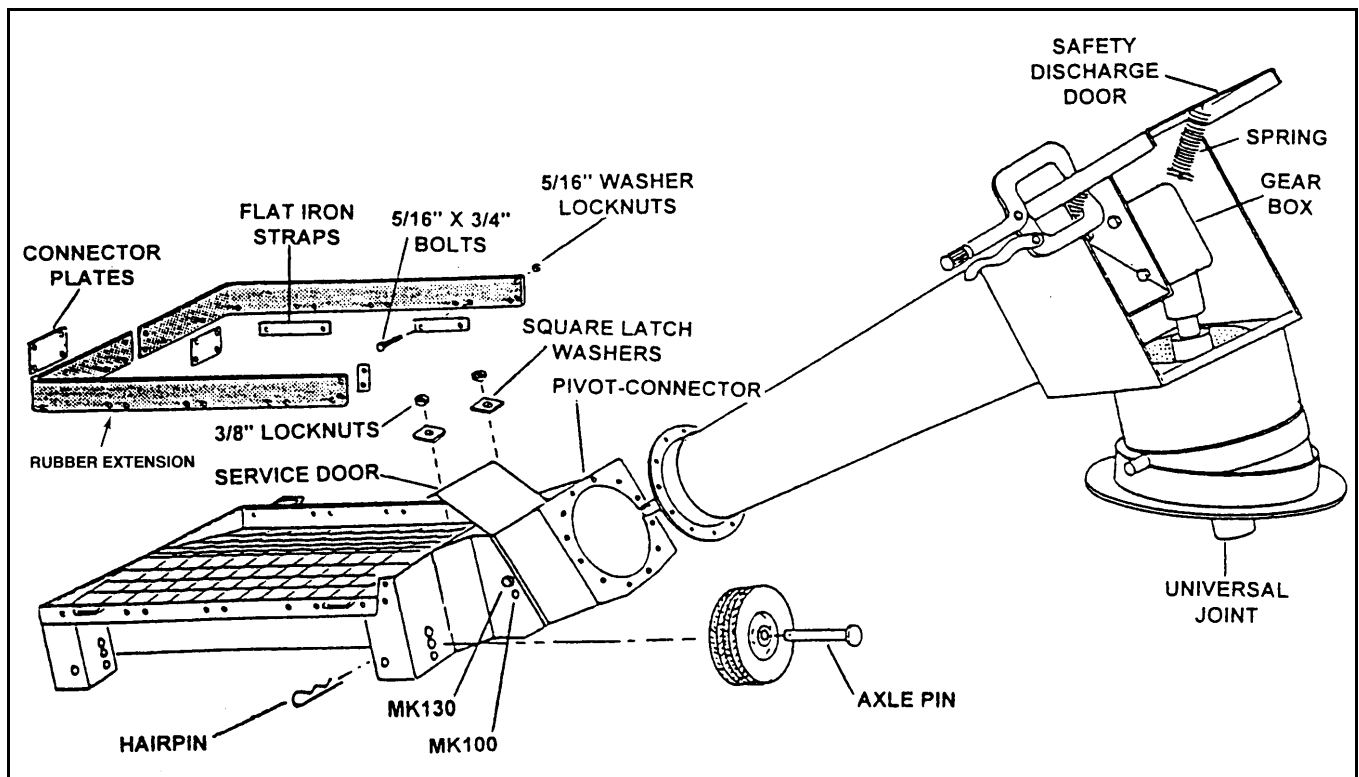

Figure 3.36

7. Tighten set screws on u-joints, then close and secure the service door.
8. Remove the two 5/16" washer locknuts that secure the chain drive guard. Attach the 2-piece rubber extension to inside of hopper lip with 5/16" x 3/4" bolts and washer locknuts and the flat iron straps provided, plus the 2-piece extension connector plates.
9. Attach the 4 pneumatic wheels to the 4 hopper corners with the axle pins and hairpins. The offset portion of the wheel must rest against the hopper.
  - You have a choice of 3 height settings.
- ➔ 10. **Mechanical Drive Units Only:** Open the safety discharge door to connect the intake hopper to the auger boot.
  - This door is held in place internally with 2 springs. To open, pull the door down, and then up and over the gearbox enclosure. Hold open with C-clamp vise grip.

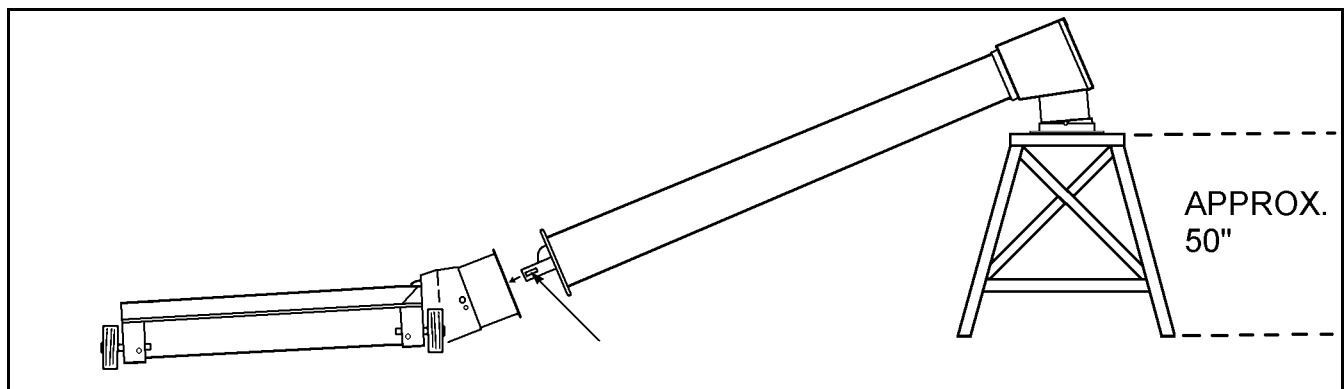

Figure 3.37

11. Place wide rim 1-1/4" washer guard over splined shaft on lower gearbox.
  - a. Clean u-joint spline and splined shaft on lower gearbox, then apply a light film of grease on this splined shaft.
  - b. Guide the splined universal joint onto splined shaft while intake hopper is lowered onto the boot. Once positioned, the swivel ring rests flat on the boot surface and inside the four spacer nuts.
12. Install 4 large washers with 3/8" x 3/4" bolts to keep the intake hopper in place on the boot.
13. Lubricate the universal joint and then close the safety discharge door.

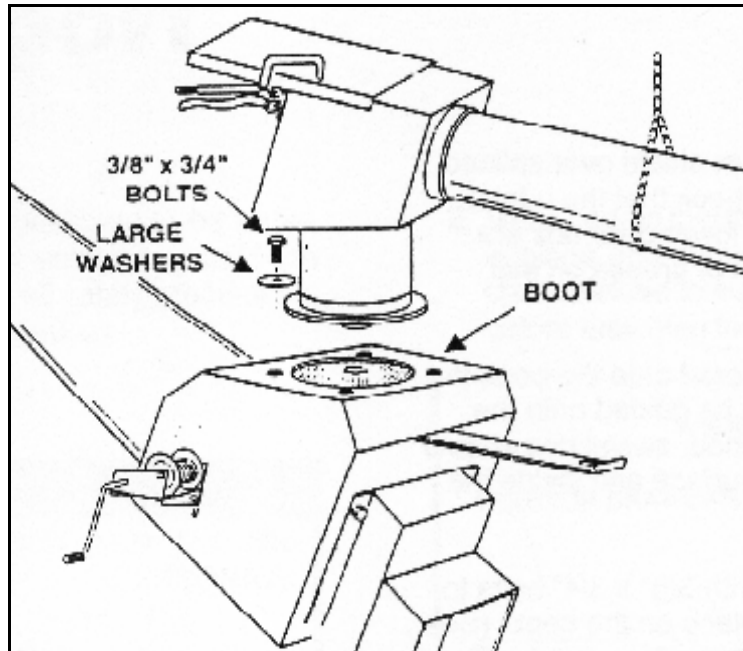



Figure 3.38

## 3.14. HITCH JACK

The jack is attached to the auger with a pin at the pivot point. To install:

1. Elevate the auger boot (intake end) approximately 2' with a front-end loader and sling, and install the jack in a vertical position. Secure it with the supplied pin.
2. Place a board beneath the jack before setting it on the ground, then lower the auger until the jack is seated. Remove front-end loader from auger.

**Note:** Jack can be rotated 90° for transport or operation.

<b>WARNING</b>	
	<p>Jack is designed for raising or lowering auger hitch only.</p> <p>Do not get on or beneath auger while supported by or while jack is being operated.</p>

## 3.15. AUGER-TO-TRACTOR HOOKUP

**Important:** *Auger must be hooked up to tractor for all operations including transport, raising, placement, and augering grain.*

### 3.15.1. PTO DRIVELINE / DRAWBAR

The final stage of the MK assembly is attaching the auger to the tractor.

#### HITCH PIN

When attaching the MK auger to your tractor, you must leave space between the bottom of the tractor drawbar and the top of the securing device on the hitch pin.

- To secure, use 2 nuts locked against each other.
- The space should be about 3/4" to 1" as shown below.

Important:

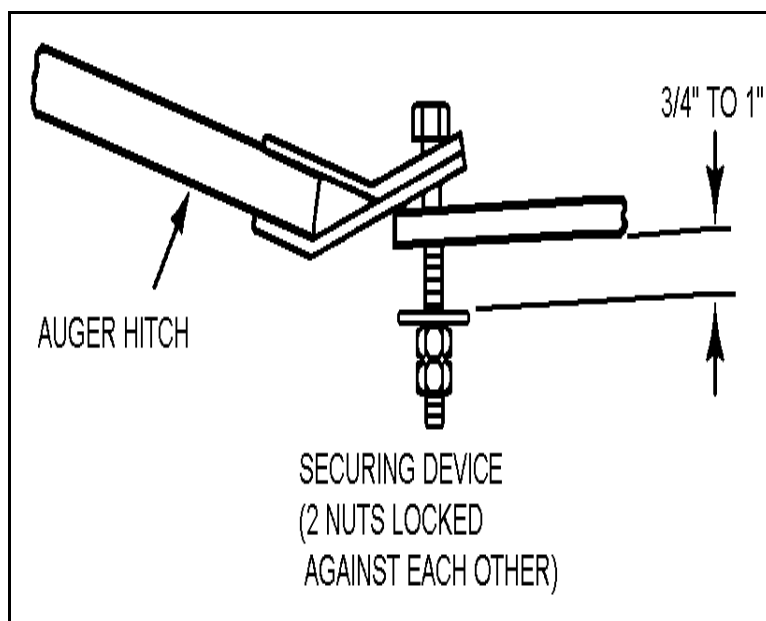

#### MEASUREMENTS BETWEEN DRAWBAR AND DRIVELINE

Since the auger and tractor become an integral unit during transport, placement, and operation, the configuration and measurements between the tractor drawbar and the tractor PTO driveline are very important.

The figure below illustrates the ideal measurements. Most tractors fall into this range.

- Dimension (B) may range from 6" to 10" with 8" being ideal.
- If dimensions (A) and (B) on your tractor are as shown, then dimension (C), which is critical, will be correct.
- If (A) and (B) vary on your tractor from the recommended dimensions, consult the table below for potential problems and their solutions.

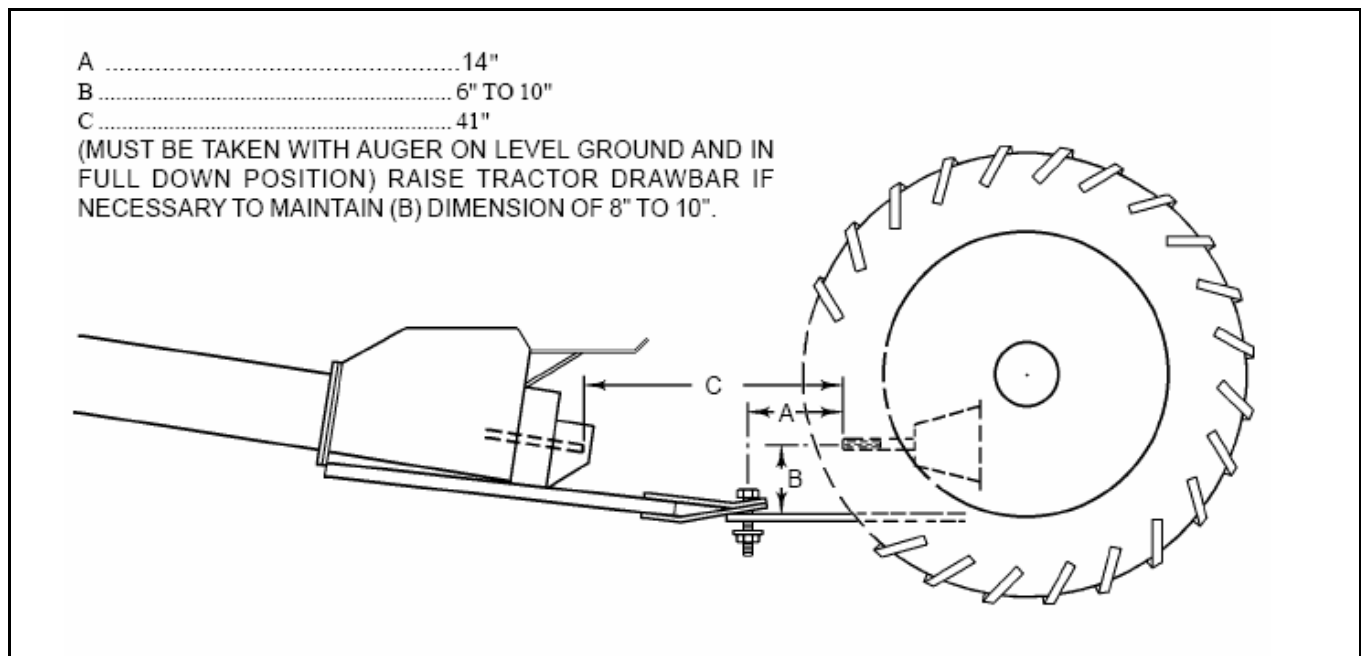

Figure 3.39 Figure 3.1

MEASUREMENT	PROBLEM	SOLUTION
If (A) is less than 14" • (C) will be less than the recommended 41"	<ul style="list-style-type: none"> <li>The PTO driveline will bottom out when auger is in raised position.                             <ul style="list-style-type: none"> <li>This will cause damage to the PTO driveline, the bearing, or the boot housing.</li> </ul> </li> </ul>	<ul style="list-style-type: none"> <li>Pull out or lengthen the tractor drawbar as needed to make (C) 41" when the auger is in full down position.</li> </ul>
If (A) is more than 14" • (C) may be more than the recommended 41"	<ul style="list-style-type: none"> <li>The PTO driveline will separate from the auger in the lowered position.                             <ul style="list-style-type: none"> <li>This will cause damage to equipment and/or injury to personnel.</li> </ul> </li> </ul>	<ul style="list-style-type: none"> <li>Shorten distance (C) to the recommended 41" by attaching hitch to tractor drawbar at a point closer to the tractor PTO shaft.</li> </ul>
If (B) is more than 10" • (C) (between tractor PTO shaft and auger input shaft) shortens more quickly when auger is being raised	<ul style="list-style-type: none"> <li>The u-joint angle on the PTO driveline will be too severe in the raised position.</li> <li>The PTO driveline will bottom out before auger is fully raised.                             <ul style="list-style-type: none"> <li>This will cause damage to the PTO driveline, flight shaft, bearing, and boot.</li> </ul> </li> </ul>	<ul style="list-style-type: none"> <li>Raise the tractor drawbar until dimension (B) is within the recommended 8" to 10".</li> </ul>



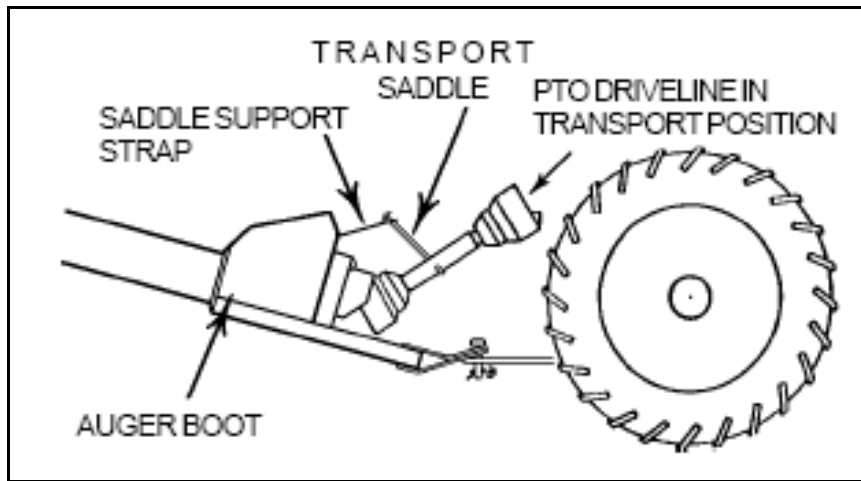

Figure 3.40

### 3.15.2. HYDRAULIC HOSE COUPLERS

Check in your tractor manual or with your dealer regarding the correct type of coupler to use on your auger. Make sure hose ends are free of dirt before securing to coupler.

### 3.16. PLASTIC MANUAL HOLDER

Before beginning installation, ensure that all winch / auger lift controls are locked in place and shut down and/or lock out auger.

1. Attach holder to the lower frame arms. Manual holder must be accessible at all times, whether frame is up or down.
2. The manual holder cap must face up (towards the intake end). Attach manual holder with supplied zip ties. Tighten the zip ties, securing the holder in place.

**Note:** *Where possible, attach the zip ties around a frame brace tab to prevent the manual holder from slipping down the lower frame arms.*

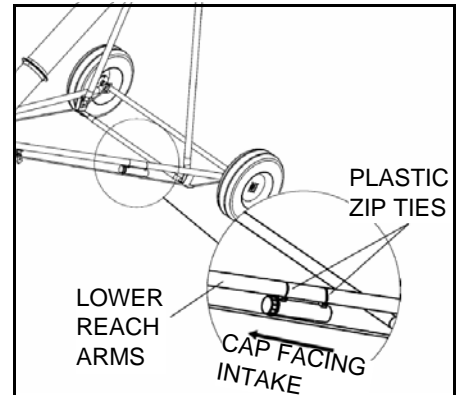



Figure 3.41



# 4. Transport & Placement

**Warning:** Before continuing, please reread the safety information relevant to this section at the beginning of this manual. Failure to follow the safety instructions can result in serious injury, death, or property damage.

This auger is designed to be transported and operated without unhitching unit from tractor.

CAUTION	
	Always tow auger in the lowered position. Disconnect PTO driveline from tractor for transport and placement.

## 4.1. TRANSPORT PROCEDURE

1. Place auger in full down position.
  - disconnect PTO driveline from tractor
  - seat roller track shoe against the upper trackstop with slight tension on the lift cable
2. Position and secure hitch pin and safety chain. Place safety chain through clevis welded to auger hitch tube and bolt together before attaching to tractor.
3. Raise intake feed hopper into transport position and secure with saddle pin and hairpin.
- 4.

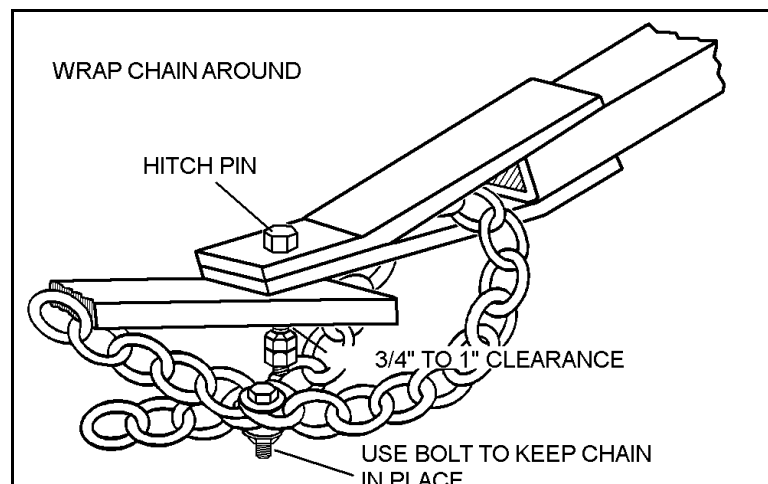

Figure 4.1

**Note:** Do not operate auger with intake hopper in transport position. This will damage the u-joint.

5. Place swivel jack (on side of hitch) in transport position and lock.

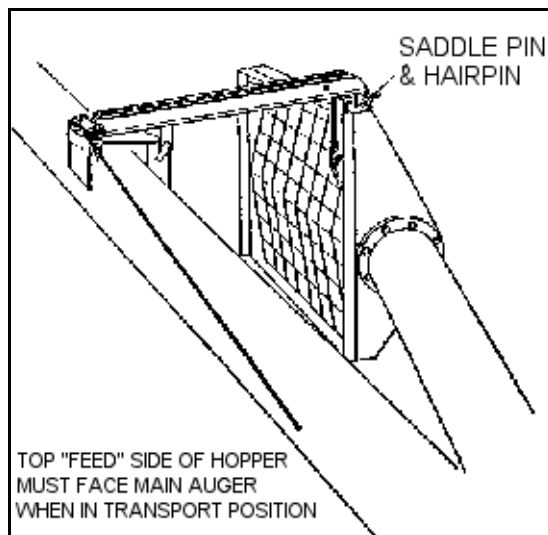



Figure 4.2

<b>CAUTION</b>	
	<p>If auger wheels are partially or fully buried in snow or grain, failure to clear the area around the wheels before moving may cause damage to the auger or result in serious injury.</p>

**Important:** *Intake feed side of hopper must face main auger when in transport (Figure 4.2)*

6. Clear all untrained personnel from transport zone.

<b>WARNING</b>	
	<p>Beware of overhead obstructions and electrical wires and devices. The MK130 Plus augers have minimum clearances from 13'6" to 14'6" (4.11 m to 4.42 m).</p>

7. **MK130 Plus 81'**: do not transport the auger with the axles extended.
8. To place in transport position:
  - a. Lock in transport position with the handles on the side of the hopper.
  - b. Attach cable hook to the loops inside the hopper.
  - c. Fully raise hopper with intake side facing away from the main auger as shown.
  - d. Secure hopper to lift arm with the hopper lock, saddle pins, and hairpins provided.

## 4.2. PLACEMENT PROCEDURE

### WARNING



Auger must be hooked up to tractor for all operations, including transport, raising, placement, and augering grain.

1. Disconnect PTO driveline from tractor and secure in transport saddle.

### NOTICE

When positioning the MK auger, the PTO driveline must be disconnected from the tractor and placed in the transport saddle to prevent damage to auger and PTO driveline.

2. Position and secure towing hitch.

**Important:** Use a type of hitch pin (see *Auger / Tractor Hookup* section) that will not allow auger to separate from towing vehicle.

- Important:**
3. Because of the many different kinds of tractor hydraulic systems, the quick-connect coupler must be supplied by the owner. Please consult your tractor manual or dealer for the proper coupler.
    - Before connecting hose, ensure that the quick-connect coupler on auger and tractor is clean and free of dirt by wiping with a cloth.

### CAUTION

Dirt in the hydraulic system can damage the cylinder o-rings, causing leakage and the possible failure of the system and personal injury.

4. Connect hydraulic hoses, ensure connections are tight. Check for leaks, binding, flattening, kinks, or wear.
5. If the auger must be raised for positioning:
  - a. Check that valve on hose to lift cylinder is open.
  - b. Raise auger to the desired height.
  - c. Close hose valve (after auger is positioned).

➔ The **MK130 Plus 81'** auger features a new hydraulic lift system that only needs a small amount of hydraulic oil to raise the auger. This is done by pumping oil into and out of the upper chamber of the cylinder as the auger is raised and lowered. For this system to work, **the tractor must be running** and the down lever must be fully engaged as auger is lowered.

**NOTICE**

The hydraulic cylinders are shipped without oil and must be charged with oil before auger is put into operation. See the appendix for charging instructions.

**WARNING**

Fluid leaks in the hydraulic cylinder or hose will allow auger to lower inadvertently.

Repair all leaks and breaks immediately.

**CAUTION**

If hose valve remains open, a loss of hydraulic pressure within in the tractor system will allow the auger to lower inadvertently, damaging the equipment and causing personal injury.

**WARNING**

Do not disconnect coupler under pressure. Relieve pressure and then disconnect.

- ➔ 6. For the MK130 Plus 81', ensure the axles are extended before raising auger.

<b>Axle Extension Procedure for MK130 Plus 81' Auger Only</b>
Place auger on level ground before attempting to extend or retract the axle extensions. <b>Auger must be attached to tractor at all times.</b>
Once the auger is in position, you may begin the axle extension process.
<ol style="list-style-type: none"> <li>1. Using the jack supplied, insert it into one of the jack lugs located on the lower reach arm near the axle (Figure 4.3). <ul style="list-style-type: none"> <li>• Jack must be secured to jack lug using pin (attached to jack).</li> </ul> </li> <li>2. Raise one side at a time. Jack must be oriented vertically. Turn the crank to start raising the jack. Raise one side of the axle until the tire clears the ground.</li> <li>3. Remove the axle pin from the axle and slide the axle outwards 16" until the second set of holes line up (Figure 4.3). Reinsert the pin and secure with snap pin. Lower the jack.</li> <li>4. Repeat the process on the other side of the axle to extend the other side.</li> </ol>
To retract the axle, follow the same procedure in reverse, but in step 3, slide axle inwards instead of outwards.

<b>WARNING</b>	
	<p>Do not raise the MK130 Plus 81' auger unless the axles are in the extended position.</p> <p>Do not transport the auger unless the axles are in the retracted position.</p>

7. Move the auger into working position slowly. Do not unhitch and attempt to move auger by hand.
8. Once auger is in position, chock wheels on both sides and apply the park brake on the tractor (or chock its wheels as well) to prevent movement during operation.
9. Fully lower hopper to the ground and remove lift cable from the hopper.
  - See “Lowering & Completion” on page 61 for the correct lowering procedure.

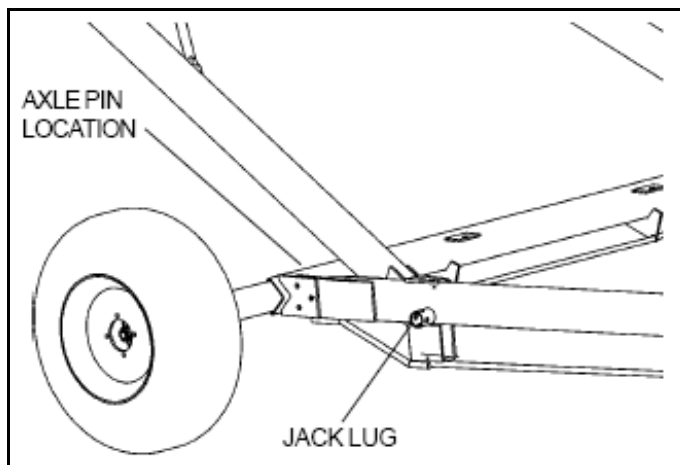

**Figure 4.3**

**TO LOWER THE AUGER YOU MUST:**

1. Reconnect hose coupler to tractor, if disconnected.
2. Disconnect PTO driveline from tractor before lowering.
3. Ensure that area beneath auger is clear.
4. Open hose valve.
5. Open tractor valve, feathering to prevent too rapid a descent.

➔ For MK130 Plus 81' auger, start the tractor, then engage the hydraulic lever in the down position to lower. This pumps oil back to upper chamber of the hydraulic cylinders, preventing overflow of tractor reservoir.

**Important:** *Once valves are opened, auger lowers by gravity. As the auger nears the full down position, the rate of descent will increase. Do not operate with tractor valve fully open. See "Lowering & Completion" on page 61 for more details.*

CAUTION	
	Do not use auger as a hoist to raise any object regardless of weight. This will create an unsafe condition and will void warranty.



# 5. Operation

**Warning:** Before continuing, please reread the safety information relevant to this section at the beginning of this manual. Failure to follow the safety instructions can result in serious injury, death, or property damage.

Operators must observe safety procedures at all times and follow the pre-operational checklist before each start-up.

## 5.1. PRE-OPERATION CHECKLIST

---

Before operating auger each time, the operator must confirm the following:

- All fasteners are secure as per assembly instructions.
- Cable clamps are secure.
- Hydraulic hoses are in good condition.
- Hydraulic connections are in place and secure.
- PTO driveline is connected and secure.
- PTO driveline shield rotates freely.
- Tube alignment is reasonably straight.
- Intake area and discharge spout are free of obstructions.
- Auger wheels are chocked, and if necessary, tractor wheels are chocked or the parking brake has been engaged.
- Proper maintenance has been performed.
- Tractor and auger are in line or as close to being in line as possible.
- **MK130 Plus 81'**: ensure that the axles are extended during operation (Section 4.2.).
- Know how to safely shut down auger in an emergency.



## 5.2. AUGER DRIVE & LOCKOUT PROCEDURE

**Note:** *If shearbolt in the PTO driveline fails, shut down and lock out tractor to replace bolt.*

The MK130 Plus uses one 3/8" x 1" grade 8 bolt through the shank shear. Part 18454 includes nut.

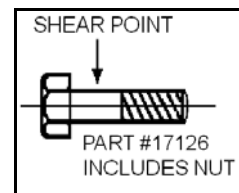

Drive Type	Before Operation	Lockout
PTO Driveline	<p>Before starting, ensure</p> <ul style="list-style-type: none"> <li>• PTO driveline is securely attached to the tractor and jack-haft</li> <li>• tractor park brake in engaged and/or wheels are chocked</li> <li>• you are not exceeding the maximum operating length of 40-5/8" of the PTO driveline</li> <li>• PTO drive on the tractor is in the off position</li> </ul>	<p>Shut off tractor's engine and remove key or coil wire from tractor.</p> <ul style="list-style-type: none"> <li>• If removing key is impossible, remove PTO driveline from tractor.</li> </ul>

## 5.3. HYDRAULICS

1. Ensure that the hydraulic line is properly connected and secure.
2. Keep hydraulic line away from moving parts.
3. Do not disconnect the hydraulic coupling when under pressure. For the correct procedure, consult this manual or your tractor manual.

<b>WARNING</b>	
	<p>Escaping hydraulic fluid under pressure can cause serious injury if it penetrates the skin. Wear protective clothing when working around hydraulic equipment.</p>

## 5.4. OPERATING PROCEDURE

---

### 5.4.1. INITIAL START-UP

---

#### BREAK IN

CAUTION	
	Auger must be hooked up to tractor for all operations, including transport, raising, placement, and augering of grain.

**Note:** *The angle drive on the standard intake hopper requires a break-in period of at least 2 or 3 loads of grain.*

1. Ensure auger is properly placed and complete the pre-operational checklist. If everything is satisfactory, prepare for one hour of operation at half speed.
2. Correctly position intake hopper.
3. Ensure that the PTO drive on the tractor is in the OFF position.

**Important:** *When starting auger for the first time, be prepared for an emergency shutdown in case of excessive vibration or noise. Auger may run rough until tube is polished.*

4. Start tractor and idle at low rpm. Slowly engage PTO drive and hydraulics (where applicable).
5. Gradually begin feeding grain into hopper, bringing auger speed up to about 300 rpm.
  - Do not overfeed the hopper on initial loads; keep feed of grain at about half capacity.
6. After auger tube is polished and runs fairly smoothly, proceed to unload at full speed of 540 rpm.
7. After initial run, slow auger down until empty of grain and then stop.
8. Lock out tractor and conduct a complete inspection of auger following the checklist.

After initial start-up and inspection, auger should be operated and inspected at least 3 more times during the first 10 hours of operation.

NOTICE
Running auger empty at high speeds results in excessive wear. Do not exceed 540 rpm.

**After Break-in:** Maintain auger speed of 300 to 540 rpm under normal use for maximum efficiency and to reduce chance of plugging.

### 5.4.2. OPERATING WITH A FULL LOAD

---

<b>DANGER</b>	
	<p><b>Rotating Flighting Hazard!</b></p> <p>To prevent death or serious injury:</p> <ul style="list-style-type: none"> <li>• Keep away from rotating auger flighting.</li> <li>• Do not remove or modify auger flighting guards, doors, or covers. Keep in good working order. Have replaced if damaged.</li> <li>• Do not operate the auger without all guards, doors, and covers in place.</li> <li>• Never touch the auger flighting. Use a stick or other tool to remove an obstruction or clean out.</li> <li>• Shut off and lock out power to adjust, service, or clean.</li> </ul>

- Monitor the auger during operation for abnormal noises or vibrations.
- **If grain overflows** through safety discharge door, then the auger is loaded beyond its capacity; reduce volume of feed going into intake hopper. Remember, auger capacity will decrease as the auger's angle increases.

**USE OF GRAIN SPREADERS:** Many grain spreaders cannot handle the large capacity of some augers. Some augers plug, causing damage to the flighting and other drive components. This type of damage is not covered by warranty. Hints on how to avoid this...

- Get a larger spreader, if available.
- Remove the spreader.
- Make sure spreader is turned on.
- Center auger spout on spreader.
- Do not lower auger spout into spreader.
- Suspend the spreader from bin ceiling leaving extra room for excess grain to flow over the spreader.

**BIN LEVEL INDICATORS:** These augers are fast and bins fill up quickly. A full bin will cause auger to plug, which can damage the flighting and other drive components. Installing quality grain-level indicators on your bins will allow you to monitor bin filling and help prevent damage to your auger.

### 5.4.3. SHUTDOWN

---

#### **NORMAL SHUTDOWN:**

1. Near the end of a load, decrease auger speed until all grain is clear of machine.

2. When auger is clear of grain, disengage PTO drive.
3. Shut down and lock out tractor.

### **EMERGENCY / FULL-TUBE RESTART:**

1. If cleanout covers or safety doors have been opened or removed, close or replace them before restarting the unit.
2. If the auger is shut down for an emergency, lock out tractor before correcting the problem.
  - If the problem is plugging, clear as much of the grain as possible using a piece of wood, wet/dry vac, or other tool before restarting auger. **Do not reach in and use your hands** even if the tractor has been locked out.
3. If auger tube is full of grain, do not restart at full speed. Engage PTO at low rpm, gradually increasing power until normal operating speed is reached.

### **NOTICE**

Starting the auger when there is grain blockage will result in damage.

## **5.4.4. LOWERING & COMPLETION**

---

After operation:

1. Clean entire work area.
2. Remove all supports and chocks.
3. Move auger out of working position and lower fully (see shaded box that follows for lowering procedure).
4. Move auger to the next work area or to a storage area and then clean out.

**LOWERING**

1. Raise the intake feed hopper. Do not attempt to lift by hand.
  2. Reconnect hose coupler to tractor, if disconnected.
  3. Disconnect PTO driveline from tractor before lowering.
  4. Ensure area beneath auger is clear and wheels are free to move.
  5. Open hose valve.
  6. Open tractor valve, feathering to prevent too rapid a descent.
    - Once valves are open, auger lowers by gravity. As the auger nears the full down position, the rate of descent increases. Do not operate with tractor valve fully open.
    - **For the MK130 Plus 81'**: start the tractor, then engage the hydraulic lever in the down position to lower.
  7. After auger is fully lowered, raise the intake feed hopper into full transport position.
    - Never operate auger with intake feed hopper in transport position. This will damage the universal joint.
5. Clean out auger.
    - a. Shut off tractor engine and lock out power.
    - b. If necessary, open cleanout cover on the boot and manually clean out grain with a piece of wood, vacuum cleaner, or other tool. Do not use hands.
    - c. Replace cleanout cover.
    - d. Winch intake feed hopper into transport position and clean out remaining grain using a piece of wood or other tool.
  6. Prepare for transport and placement or storage (see appropriate chapters for more information).

# 6. Maintenance & Storage

**Warning:** Before continuing, please reread the safety information relevant to this section at the beginning of this manual. Failure to follow the safety instructions can result in serious injury, death, or property damage.

## 6.1. GENERAL MAINTENANCE PROCEDURES

Please follow the guidelines below.

Area	Maintenance Procedures	Frequency
General	While auger is in use, observe the checklist in Section 5.1.	Daily
General	Check all operating, lifting, and transport components. Replace damaged or worn parts before using auger. <ul style="list-style-type: none"> <li>For replacement instructions: See "Assembly" on page 19.</li> </ul>	Regularly
Intake Hopper Angle Drive	Lubricate the angle drive with high-temperature grease. <ul style="list-style-type: none"> <li>If the angle drive in hopper runs hot AFTER the recommended break-in period, this may mean the angle drive is not properly aligned. <b>To align</b>, lock out power, loosen the bolts securing the angle drive, and then adjust or shim up until the flight can be easily rotated by hand.</li> </ul>	After every 8 hours of use
Hydraulic Hose	Using cardboard as a backdrop, check hose and hose coupler for leaks, wear, and damage. Replace if necessary. See "Hydraulic Safety" on page 11. <ul style="list-style-type: none"> <li>Replacement hose and hose ends must have a minimum strength of 2750 psi (18,961 kPa) working pressure.</li> </ul>	Frequently
Lift Cable	Check and replace if frayed or damaged. Make sure cable clamps are secure.	Periodically
Cable Sheaves	Oil sheave pins on lift cylinder.	Twice/year
Truss Cables	Adjust to keep auger tube reasonably straight.	As necessary
Wheel Hubs	Repack with lithium-based grease.	Every 2–3 years
Tire Pressure	Check with a pressure gauge. Pressure should be maintained according to sidewall recommendations.	Monthly, or if it seems low
Hopper Lift Cable	Check and replace if frayed or damaged.	Periodically
Hopper Lift Cable Pulleys	Oil lightly for easier raising of hopper.	Several times a year

Area	Maintenance Procedures	Frequency
Winch	Keep a film of grease on gears.	Regularly
	Oil the bushings, drum shaft, and ratchet. <ul style="list-style-type: none"> <li>• Take care not to get oil or grease on brake discs. Service winch with auger in fully lowered position and cable slack.</li> </ul>	Occasionally
	Replace brake discs if less than 1/16" thick.	As required
	Service winch with auger in fully lowered position and cable slack.	Regularly
PTO Driveline	Lubricate all 5 grease fittings (Figure 6.1) with good quality Lithium Soap Base E.P. Grease meeting NLGI #2 specifications and containing no more than 1% molybdenum disulfide (example: Shell Super Duty). <ul style="list-style-type: none"> <li>• Grease fittings No. 2 and 3 can be reached through hole in implement end portion of the driveline guard.</li> <li>• Grease fitting No. 4 can be reached through hole in center portion of the driveline guard.</li> <li>• The first lube interval should be 16-24 hours of operation after initial start-up, then follow the schedule.</li> </ul>	After the first 16–24 hours and then regularly afterward
General	Ensure that the set screws and shear-bolt are tight.	Regularly
Optional Lower Profile Hopper	Loosen the 2 nuts securing the service door. Open door, then grease the 4 bushings and the 2 u-joints. Close door, then securely tighten the two 3/8" nuts.	Frequently
	Check and adjust the hopper drive chain and lubricate the hopper drive chain. To adjust chain, loosen the bearing bolts and adjust chain tension to about 1/4" deflection. <b>Replace guard.</b>	Occasionally

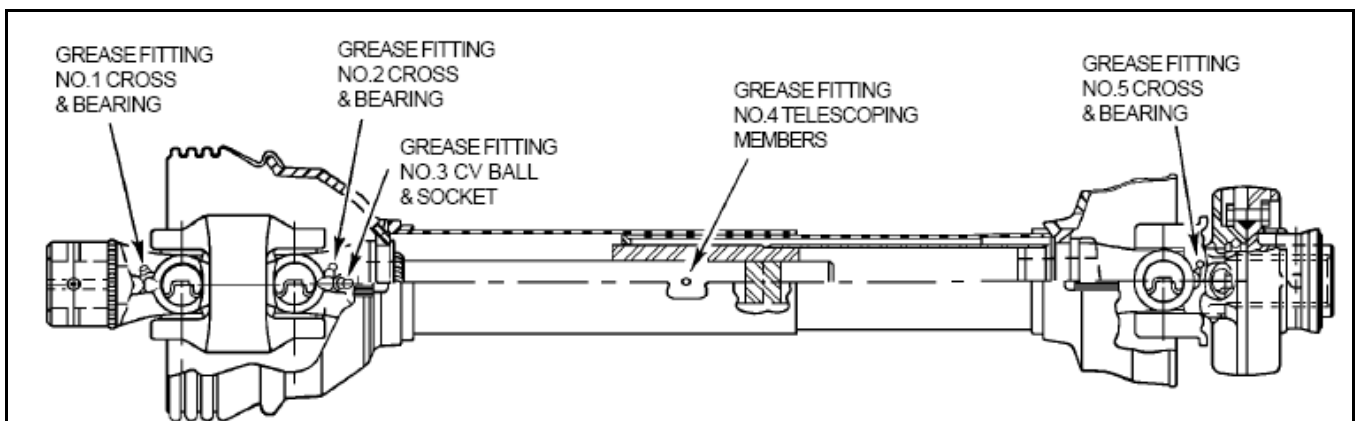

Figure 6.1



## LUBE RECOMMENDATIONS

LUBE RECOMMENDATIONS		
Interval	Location	Amount
8 hours <sup>a</sup>	Cross & Bearing	1 pump
8 hours	Telescoping Members	4-8 pumps
8 hours <sup>a</sup>	CV Ball & Socket	1-2 Pumps

a. Constant angle applications must have lube interval of four hours.

### NOTICE

Replacement parts are not lubricated. Replacement parts must be lubricated at time of assembly. Use amount listed above per location, then follow lube recommendations outlined above for lubing intervals.

## HOW TO SERVICE MECHANICAL DRIVE SYSTEM:

Area	Maintenance to Perform	Frequency
Bottom Chain Drive • Replace sprocket guard after maintenance!	Keep drive chain tension adjusted to about 1/4" deflection by loosening the four bolts on lower bearing, then re-tighten.	Regularly
	Oil chain often enough to keep film of oil on it (this can be done through the hole in the side of the sprocket guard).	Frequently
Universal Joint	Flip up safety discharge door and lubricate grease fitting in the u-joint. Check set screws and re-tighten if necessary.	After every 8 hours of operation
	Check set screws and re-tighten if necessary.	Regularly

Area	Maintenance to Perform	Frequency
Gearboxes	<p>Check oil levels in both gearboxes. They should be half full of EP90 lube oil.</p> <ul style="list-style-type: none"> <li>• Fill as needed; you may need a flexible funnel. If you notice excessive loss of oil, check more frequently and repair problem.</li> <li>• Each gearbox requires 850 mL or 30 fl oz. Do not overfill.                             <ul style="list-style-type: none"> <li>• <i>Upper Gearbox:</i> Flip up safety discharge door or open round service door to service gearbox.</li> <li>• <i>Lower Gearbox:</i> Open round service door to service gearbox.</li> </ul> </li> </ul>	At least once a year, depending on use
	<p>For more extensive servicing or repairs, remove hopper from boot assembly by removing the 3/8" x 3/4" bolts and large washers. Lift hopper with front-end loader or other secure method (Figure 6.2).</p>	As required
	<p>Check and re-tighten set screws and connecting bolts. Clean and lightly grease the splined shaft. Reattach hopper to boot assembly as per instructions in Section 3.12. or 3.13.</p>	As required
Bearing	<p>Lubricate grease fitting on lower flight bearing.</p> <ul style="list-style-type: none"> <li>• Replace sprocket guard after maintenance!</li> </ul>	As required

<b>WARNING</b>	
	<p>Do not operate auger with intake hopper not in place.</p> <p>Replace and secure service doors before operating auger.</p>

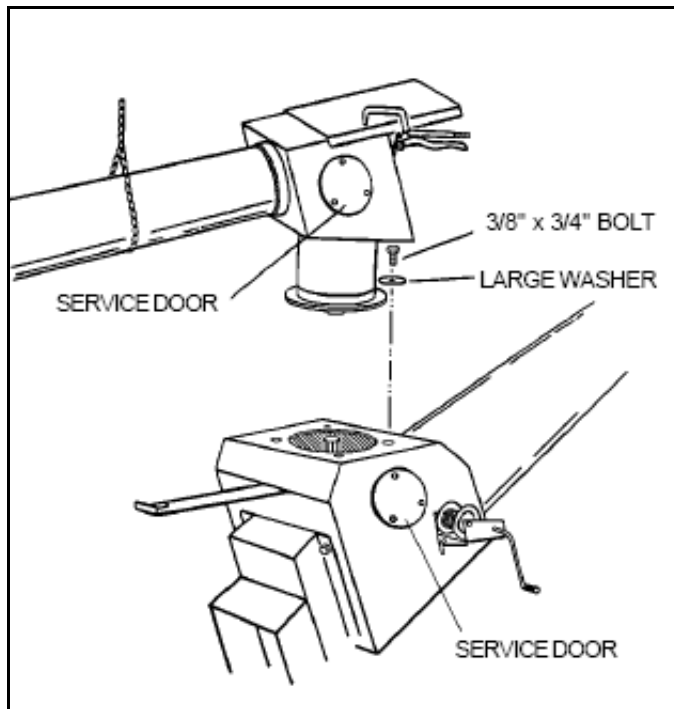

Figure 6.2

## 6.2. GENERAL STORAGE PROCEDURE

### TO PROTECT AUGER IN STORAGE DURING THE OFF-SEASON:

1. Lower the auger to full down position with slight tension on the cable.
2. Lubricate all grease fittings according to the maintenance procedure.
3. Inspect auger for damage and note any repairs required. Order replacement parts from your dealer.
4. Check tire pressure and inflate if necessary. See tire sidewall for recommendations.
5. Clean and re-lubricate spline on PTO driveline. Cover PTO driveline with plastic bag to protect it from the weather and place in the transport saddle.
6. Tow auger to storage area. Park and chock wheels.

### CAUTION



Support discharge end of auger before removing or replacing any parts on the undercarriage.

### TO PREPARE AUGER FOR USE AFTER STORAGE:

1. Check tire pressure and inflate if necessary. See tire sidewall for recommendations.
2. Tow auger to work site.
3. Remove cover from spline of PTO driveline and re-lubricate.

4. Check oil level in gearbox and refill if necessary (half full only).
5. Replace any damaged parts and decals.
6. Check and perform general maintenance before using auger.
7. Before raising auger after storage, make certain cable is in good condition, replacing it if frayed or damaged. Also make sure cable is properly seated in roller track and that cable clamps are secure.

# 7. Troubleshooting

Problem	Possible Cause	Remedy
<p><b>Excessive noise or vibration.</b></p> <p>*Remember to follow proper break-in procedures—auger may run rough until tube is polished. If noise is extreme from outset or continues after several loads of grain are fed, continue with troubleshooting below.</p>	<p>Determine if noise originates in main or swing away section of auger. Disconnecting the chain from the sprocket drive can assist in narrowing down the source of the problem. <b>If noise <i>disappears</i> when chain is disconnected, problem is likely in the swing away auger.</b></p>	
	<p>Hopper flight support bearings are dry or have failed.</p>	<p>Check for flight operation by rotating by hand with sprocket chain disconnected and tractor shut off. Grease or replace as necessary.</p>
	<p>Angle drive is misaligned or has failed (standard hopper).</p>	<p>Refer to appropriate troubleshooting section.</p>
	<p>Universal joint not greased or is faulty (low pro hopper).</p>	<p>Grease or replace as necessary.</p>
	<p>Faulty upper gearbox.</p>	<p>Refer to appropriate troubleshooting section.</p>
	<p>Obstruction in tube.</p>	<p>Visually inspect for cloth or trash wrapped around flighting, or a buildup from oily crops.</p>
	<p>Bent flight stub on swing flighting.</p>	<p>Remove flighting and roll against flat surface to determine if stub is true.</p>
	<p><b>If noise <i>continues</i> when chain is disconnected, check auger or PTO.</b></p>	
	<p>CV PTO failure.</p>	<p>Refer to appropriate troubleshooting section.</p>
	<p>Incorrectly adjusted truss cables.</p>	<p>Support end of auger and adjust cables so auger is flat or slightly curved upwards.</p>
	<p>Flighting has peeled back due to plugging.</p>	<p>Inspect spout end of auger for flight condition. Remove and replace flight sections as necessary.</p>
	<p>Faulty lower gearbox.</p>	<p>Refer to appropriate troubleshooting section.</p>
	<p>Lower bearing dry or has failed.</p>	<p>Refer to appropriate troubleshooting section.</p>
	<p>Bent flighting section.</p>	<p>Support auger and remove all flight sections. Check for straightness of flight stubs by rolling across flat section of concrete floor. Straighten stub or replace as necessary. Take care not to bend flighting when reinstalling.</p>
	<p>Obstruction in tube.</p>	<p>Visually inspect for cloth or trash wrapped around flighting, or a buildup of gum from oily crops such as flax or canola.</p>
<p>High spot at flighting joints.</p>	<p>Check with straight edge. If necessary, grind down until even.</p>	

Problem	Possible Cause	Remedy
<b>CV PTO failure.</b>	<b>Try to determine the operation and maintenance habits of the owner in order to avoid multiple repairs and unnecessary frustration.</b>	
	Broken CV ball.	Most frequently occurs when PTO driveline is not disconnected during transport or setup of the auger. Remind all operators to disconnect PTO driveline except when at the bin, in operation.
	Excessive PTO angle.	Check Assembly section for correct dimensions (auger input and tractor PTO output). It may be necessary to raise tractor drawbar to maintain correct dimensions. Extreme side-to-side angles that are necessary because of the bin and tractor placement may be corrected with a right angle drive kit.
	Early series cross-link or non-Westfield part used.	Ensure new "E" series cross links and genuine Westfield replacement parts are used.
	Telescoping part of PTO shaft bottoming out.	Pull out or lengthen tractor drawbar to maintain minimum clearance. Refer to Assembly section.
Bearings not receiving adequate grease.	Check Maintenance section—CV PTO drivelines should be greased as part of daily maintenance procedures.	
<b>Premature gearbox failure.</b>	<b>While all MK gearboxes come from the factory filled with oil, it should be part of the setup procedure to double check that a half full level is maintained.</b>	
	Failed seal.	Check gearbox levels on a regular basis and only fill with EP90 oil.
	1000 rpm tractor input being used.	Use 540 rpm tractor or install speed reducer.
<b>Angle drive fails or runs hot.</b>	<b>Angle drives require 2–3 loads to break in properly. It is normal for the angle drive to run warm to the touch during operation.</b>	
	Bearings not receiving adequate grease.	Grease frequently, especially during break-in period.
	Misaligned angle drive.	Adjust by shimming angle drive until flighting turns freely by hand. See Assembly section for details.
	Swing tube flight stub bent.	Check for straightness of flight stubs by rolling across flat concrete section. Straighten stub or replace as necessary. Maintain correct angle when re-connecting hopper and swing tube.

Problem	Possible Cause	Remedy
<b>Shear bolts fail repeatedly.</b>	Incorrect shear bolt type.	Replace with correct part number. Westfield shear bolts are specifically designed to provide correct driveline protection.
	Shear bolt hole worn out-of-round.	Frequent use of an incorrect shear bolt size can wear the mounting hole creating a “scissor effect,” which will require replacement of the affected parts.
	Corn spreaders in bin unable to keep up with auger output.	Slow down auger or remove corn spreaders.
	Flighting “peeled back” as a result of plugging.	Occurs when bin has overfilled or corn spreaders restrict end of discharge. Inspect flighting at discharge end. If necessary, replace flighting.
	Driveline failures (bearing, gear-box, etc.).	Refer to appropriate troubleshooting section.
<b>Lower bearings repeatedly fail.</b>	Bearings not receiving adequate grease.	See Maintenance section for correct greasing intervals.
	Bearing load not evenly distributed between upper and lower bearings.	Use correct sequence of tightening lock collars when setting up or replacing bearings. On MK130 Plus models, adjust bearing load using threaded upper flight stub.
	Insufficient CV PTO shaft clearance.	Maintain correct tractor hitch dimensions as per manual.
	Failure of bearing seals.	Wet grain or fertilizer will damage seals if left in boot over time. Clean out boot before storing auger.
	Bent lower flight stub.	Check for straightness of flight stub by rolling across flat concrete section. Straighten stub or replace as necessary.
<b>Premature wear on auger tubes.</b>	Auger being at low capacity or empty for extended periods of time.	Frequently occurs on farms using grain wagons. Auger should not be left unattended when filling bins. Depending on application, a belt conveyor may be more appropriate.
	Bent flighting.	Refer to appropriate troubleshooting section.
	Flighting allowed to wear beyond normal point of replacement.	When flighting becomes razor-thin at intake, replacement is critical. Since flight material is double thickness at welded lap joints, high spots on flight occur and can accelerate spot tube wear.
<b>Hydraulic lift settles out over time.</b>	Shut off ball valve is open.	Oil is leaking through tractor calve. Auger ball valve should be closed whenever set up at a bin.
	Shut off ball valve is leaking.	Disconnect hose from tractor and check for leakage.
	Lift cylinder cup seal leaking or cylinder barrel scored or pitted.	See if oil leaks from cylinder breather hole (single action cylinders). Remove and replace cup seal and hone cylinder or replace as needed.





# 8. Appendix

## 8.1. LIFT CYLINDER HYDRAULICS

This auger is elevated with two 4", single-acting hydraulic cylinders and cables. The following table lists the psi required to raise specific auger sizes (as determined by Westfield testing).

These tests used a hydraulic pressure gauge (4000 psi maximum rating) and are solely intended to be used as a guide. The psi requirements for specific augers may vary slightly. Should your auger require a significantly higher psi to raise, contact either your dealer or Westfield Industries.

AUGER	SIZE	PSI	kPa
MK130 Plus	13" x 61'	1400	9653
MK130 Plus	13" x 71'	1600	11032
MK130 Plus	13" x 81'	1500	10343

The approximate quantity of hydraulic fluid required to raise auger:

MK130 Plus 61	15 L
MK130 Plus 71	18 L
MK130 Plus 81	4 L

## 8.2. CHARGING LIFT SYSTEM (MK130 PLUS 81' ONLY)

The cylinder will require about 18 L (5.0 US gallons). Check your tractor's operation manual for correct oil type and specifications.

Before charging cylinders, ensure that:

- Tractor is correctly hooked up.
- Hydraulic hoses are connected.
- Shut-off valve is open.
- Auger is parked on level ground.

**Note:** *Do not raise auger in high winds.*

1. Start with the tractor's hydraulic oil level in a normal operating range.
2. Add about 4 L (1 US gallon) to the tractor's hydraulic oil reservoir.
3. Start tractor, then raise auger until the lift assist is fully extended and track shoe has moved about one foot from track stop.
4. **With tractor still running**, lower auger to full down position.
5. Repeat steps 2., 3., and 4. until about 18 L (5 US gallons) are added and tractor hydraulic oil level in the reservoir remains within the operating range.



# WARRANTY

Westfield Industries Ltd. warrants products of its manufacture against defects in materials or workmanship under normal and reasonable use for a period of one year after date of delivery to the original purchaser.

Our obligation under this warranty is limited to repairing, replacing, or refunding defective part or parts which shall be returned to a distributor or a dealer of our Company, or to our factory, with transportation charges prepaid. This warranty does not obligate Westfield Industries Ltd. to bear the cost of labor in replacing defective parts. Any defects must be reported to the Company before the end of the one year period.

This warranty shall not apply to equipment which has been altered, improperly assembled, improperly maintained, or improperly repaired so as to adversely affect its performance. Westfield Industries Ltd. makes no express warranty of any character with respect to parts not of its manufacture.

The foregoing is in lieu of all other warranties, expressed or implied, including any warranties that extend beyond the description of the product, and the IMPLIED WARRANTY of MERCHANTABILITY is expressly excluded.

WESTFIELD INDUSTRIES LTD.

ROSENORT, MANITOBA

CANADA

ROG 1W0

## ***WESTFIELD***

Westfield is a Division of Ag Growth Industries LP

Part of the Ag Growth International Inc. Group

P.O. Box 39

Rosenort, Manitoba, Canada R0G 1W0

Phone: (866) 467-7207 (Canada & USA)

Fax: (866) 768-4852

website: [www.grainaugers.com](http://www.grainaugers.com)

email: [sales@grainaugers.com](mailto:sales@grainaugers.com)

© Ag Growth Industries Limited Partnership 2009

Printed in Canada